



SP6015

Synchronous Rectifier Driver

DESCRIPTION

The fundamental of SP6015 synchronous rectifier (SR) driver IC is based on our U.S. patented methods that utilize the principle of “prediction” logic circuit. The IC deliberates previous cycle timing to linear control the SR in present cycle by “predictive” algorithm that makes adjustments to the turn-off time, in order to achieve maximum efficiency and avoid cross-conduction at the same time. Specially, SP6015 is designed for LLC applications, and variable switching frequency system .

The SP6015 is a dual fast turn-off intelligent controller to drive two N-CH power MOSFETs in LLC resonant converters for synchronous rectification.

FEATURES

- Offers efficiency improvement over Schottky Diode.
- Low Standby Power to meet DOE Lot 6 Requirement .
- Dual gate driver for N-channel MOSFET
- Drives all level Power MOSFET.
- Prediction gate timing control.
- Minimum MOSFET body diode conduction.
- Operating frequency up to 250 KHz.
- Synchronize to transformer secondary voltage waveform.
- Self detect DCM / CCM to enhance the performance under the variable switching frequency condition.

APPLICATIONS

- Storage area network power supplies
- Telecommunication converters
- Embedded systems
- Industrial & commercial systems using high current processors
- Power converters to meet Lot 6 requirement

PIN CONFIGURATION (SOP-10)

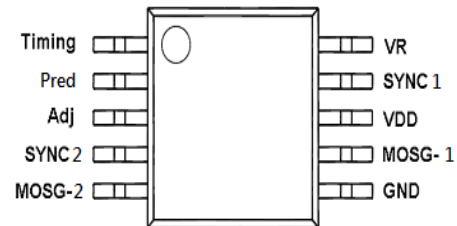

PART MARKING

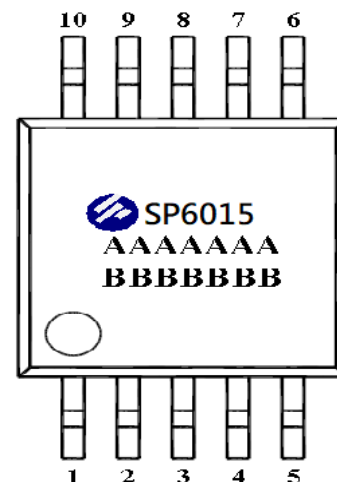

A : Lot Code
B : Date Code



SP6015

Synchronous Rectifier Driver

TYPICAL APPLICATION CIRCUIT

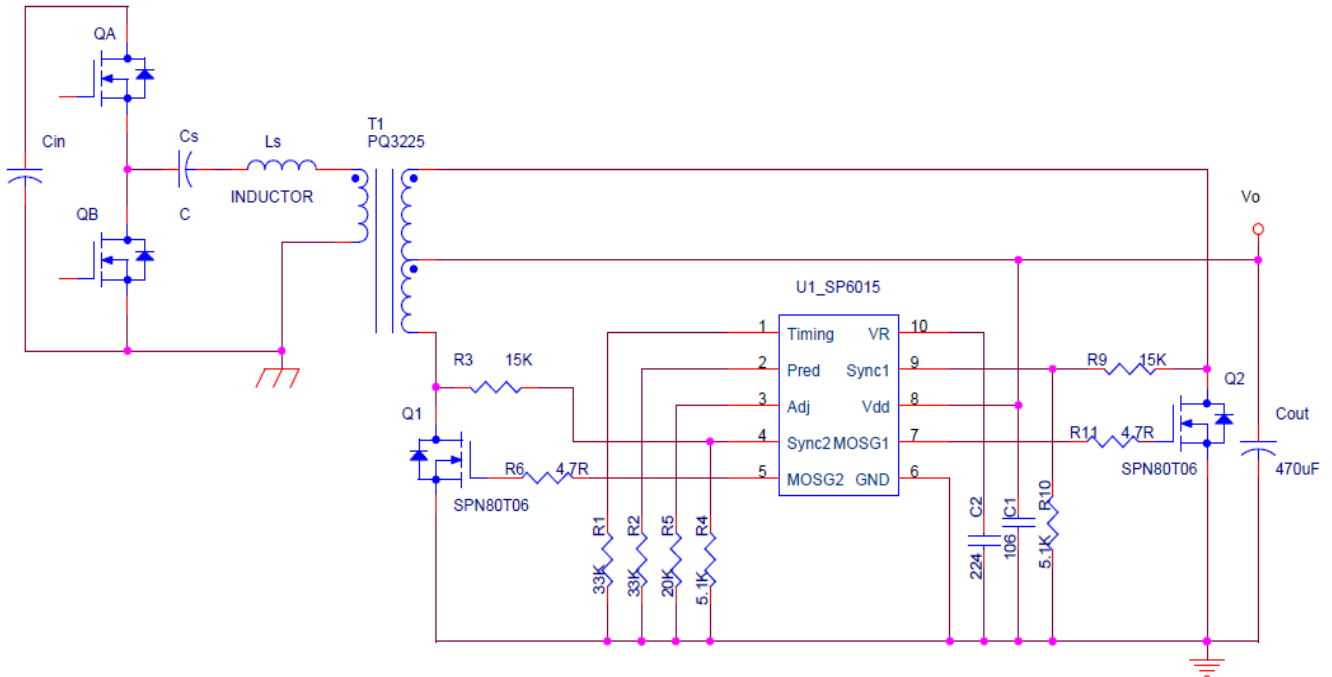

PIN DESCRIPTION

Pin	Symbol	Description
1	Timing	Discontinuous current filter timing adjustment resistor connection.
2	Pred	Capacitor to store previous cycle timing for SR MOSFET.
3	Adj	Trigger point adjustment for Dynamic state.
4	SYNC-2	Synchronized signal from the V_{DS} of SR MOSFET.
5	MOSG-2	Catch MOSFET gate drive.
6	GND	Ground connection.
7	MOSG-1	Catch MOSFET gate drive.
8	Vdd	DC supply voltage.
9	SYNC-1	Synchronized signal from the V_{DS} of SR MOSFET.
10	VR	Voltage Regulator.



SP6015

Synchronous Rectifier Driver

BLOCK DIAGRAM

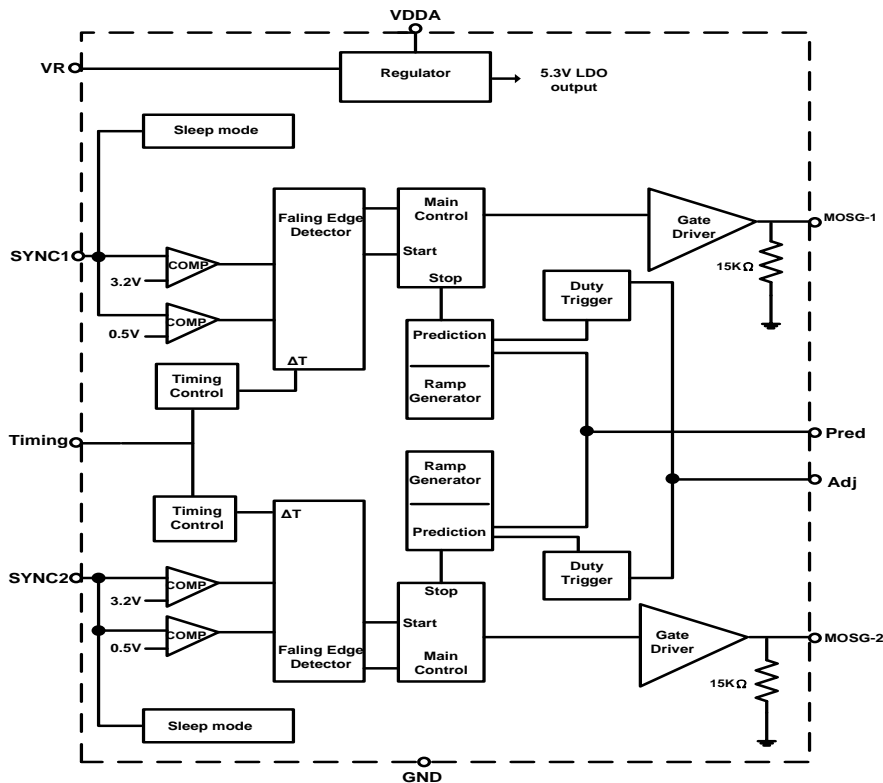

ORDERING INFORMATION

Part Number	Package	Part Marking
SP6015S10RGB	SOP-10	SP6015

※ SP6015S10RGB : Tape Reel ; Pb – Free ; Halogen - Free

ABSOLUTE MAXIMUM RATINGS (TA=25°C, unless otherwise specified.)

The following ratings designate persistent limits beyond which damage to the device may occur.

Symbol	Paramete	Value	Unit
V _{dd}	DC Supply Voltage	17.5	V
I _{OUT}	Peak Source Current (Pulsed)	2.0	A
	Peak Sink Current (Pulsed)	2.0	A
P _D	Power Dissipation @ T _A =85°C (*)	0.25	W
T _J	Operating Junction Temperature Range	-40 to 125	°C
T _{STG}	Storage Temperature Range	-40 to 150	°C
T _{LEAD}	Lead Soldering Temperature for 5 sec.	260	°C

THERMAL RESISTANCE

Symbol	Paramete	Value	Unit
R _{θJA}	Thermal Resistance Junction to Ambient (*)	130	°C/W



SP6015

Synchronous Rectifier Driver

ELECTRICAL CHARACTERISTICS

($T_A=25^{\circ}\text{C}$, $V_{dd}=12\text{V}$, Freq. =50 KHz, Duty Cycle=50%, unless otherwise specified.)

Symbol	Parameter	Conditions	Min.	Typ.	Max.	Unit
SUPPLY INPUT						
IDD	Supply current	No load		4.5		mA
		$V_{\text{SYNC}}=0\text{V}$, V_{dd} on (Sleep mode)		550		uA
Vdd	Supply voltage	I _{dd} peak < 2A			16	V
Vdd on	Enable voltage		7.9	8.3	8.8	V
Vdd hysteresis	Enable voltage			0.8		V
Vovp	Over voltage protection		16	16.3	17	V
Vovp hysteresis				0.46		V
SYNC REFERENCE (SYNC)						
Vshth	SYNC high threshold			3.2		V
Vslth	SYNC low threshold			0.5		V
Vsync WK	SYNC wake-up voltage	I _{sync} =3mA		4.6		V
Vsync	SYNC clamp voltage	I _{sync} =3mA	V _{dd} +0.7			V
I _{sync}	SYNC input current				3	mA
Voltage Regulator REFERENCE (VR)						
VR	voltage		5.2	5.3	5.4	V
I _{VR}	VR Output Current				30	mA
ON TIME DUTY SETUP (PIN 5,7)						
Ton-time		Frequency= 10KHz-20KHz, Duty=20%~50%		26	36	uS
MOSFET GATE DRIVER (MOSG-C)						
Voh	Output high voltage	I _o = -200mA	10.5	11.0		V
Vol	Output low voltage	I _o = 200mA		0.3	0.8	V
Td	Propagation delay	No load		280	380	nS
Tpred		R _{timing} =33KΩ		1000		nS
Tr	Rise time	Load = 1nF (*)		12		nS
Tf	Fall time	Load = 1nF (*)		10		nS
Dynamic Protect						
Dt	Dynamic variable	Pin3 , 51KΩ		1		uS
Ton-min	MOSG-C on time	PWM adjusts time > Dt		0.9	1	uS

(*) Tr & Tf are measured among 10% and 90% of starting and final voltage.

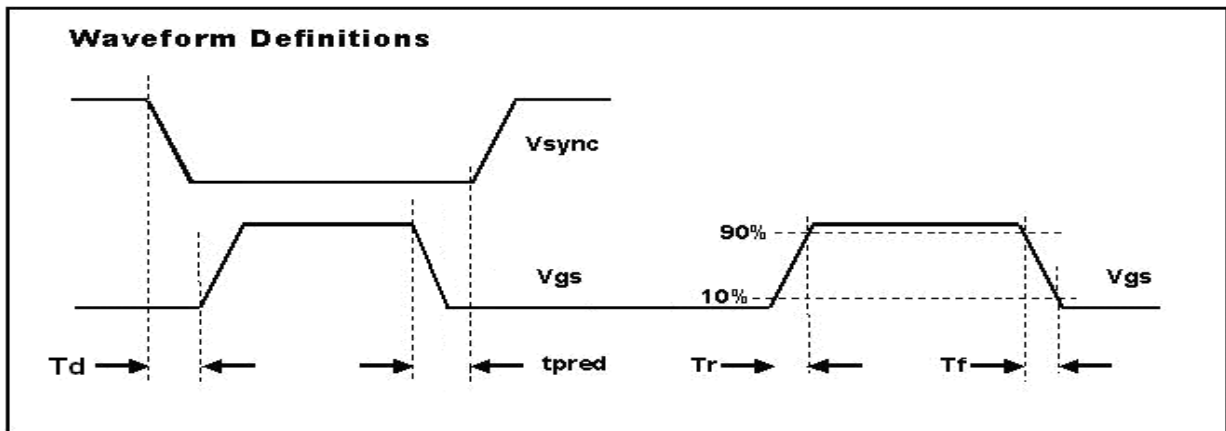



SP6015

Synchronous Rectifier Driver

PERFORMANCE CHARACTERISTICS ($T_A=25^\circ\text{C}$, unless otherwise specified.)

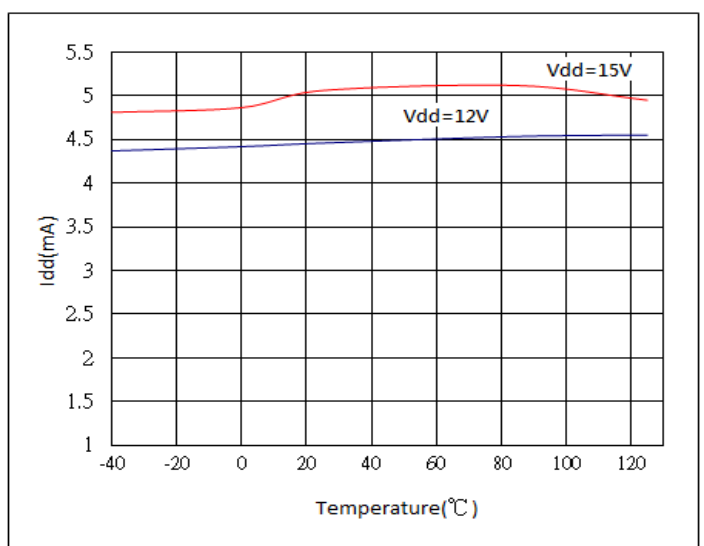
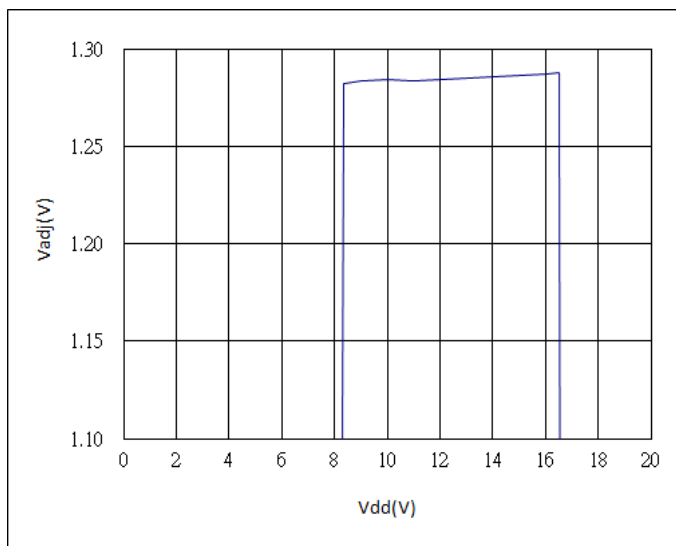
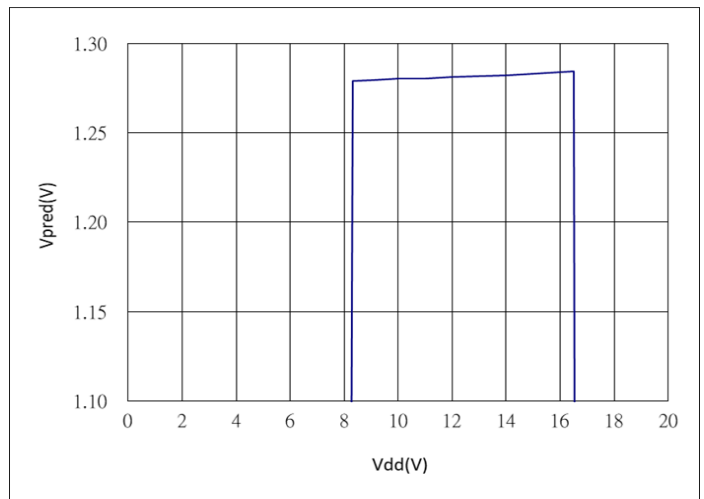
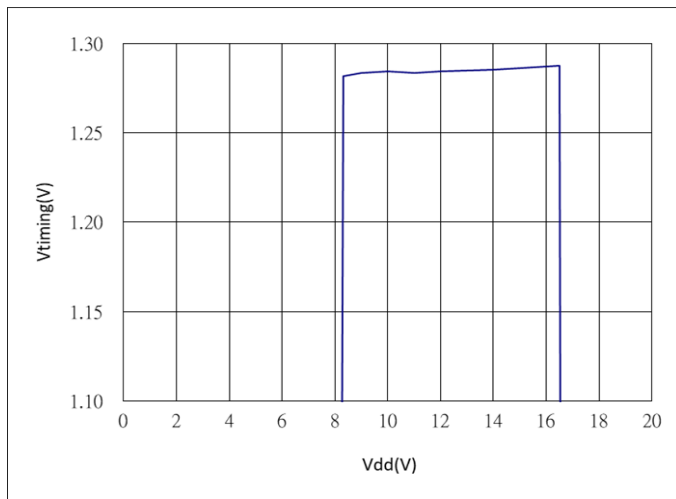
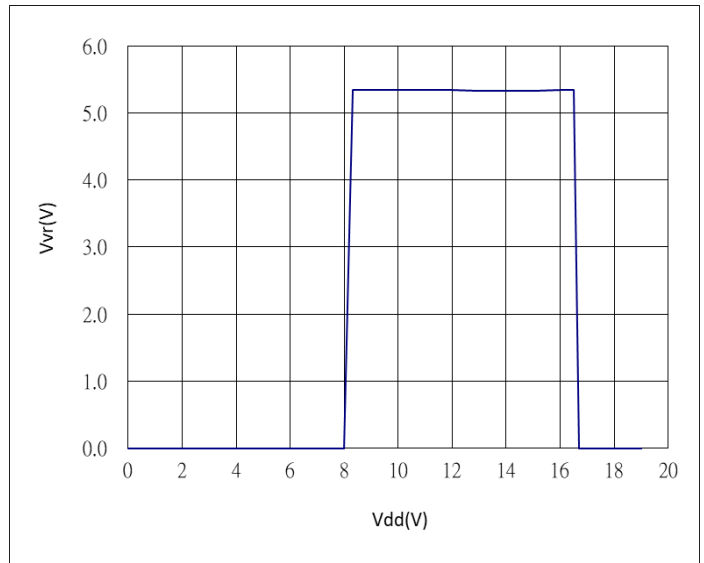
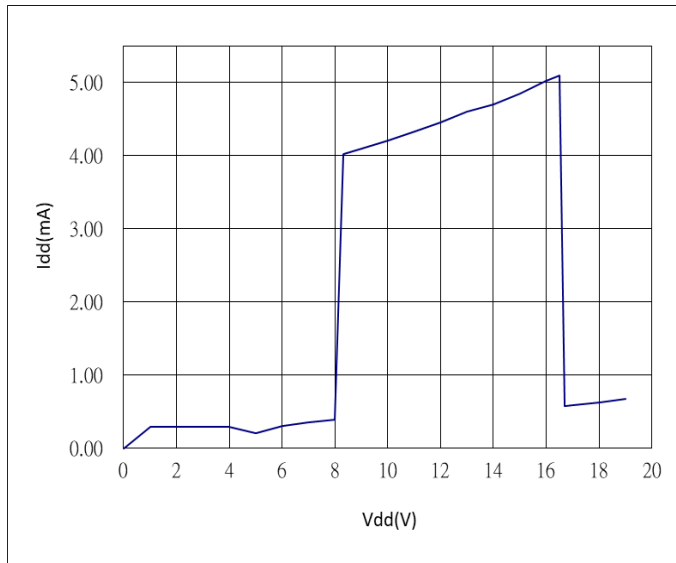



SP6015

Synchronous Rectifier Driver

PERFORMANCE CHARACTERISTICS ($T_A=25^{\circ}\text{C}$, unless otherwise specified.)

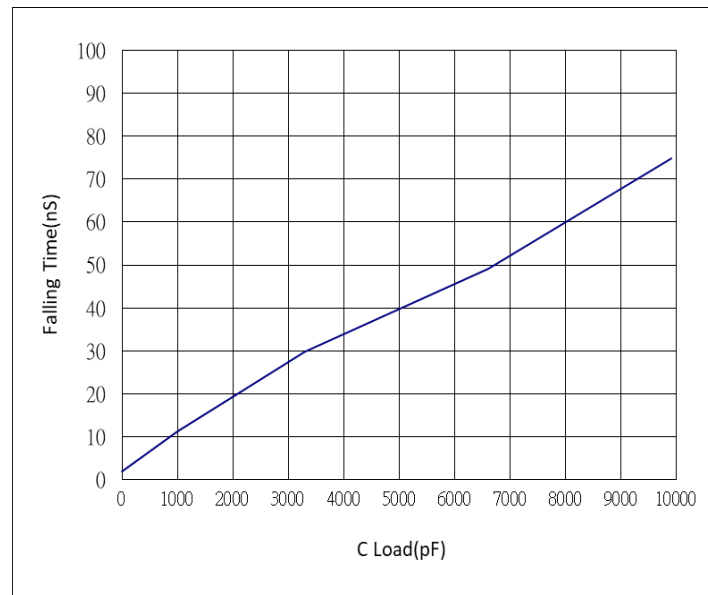
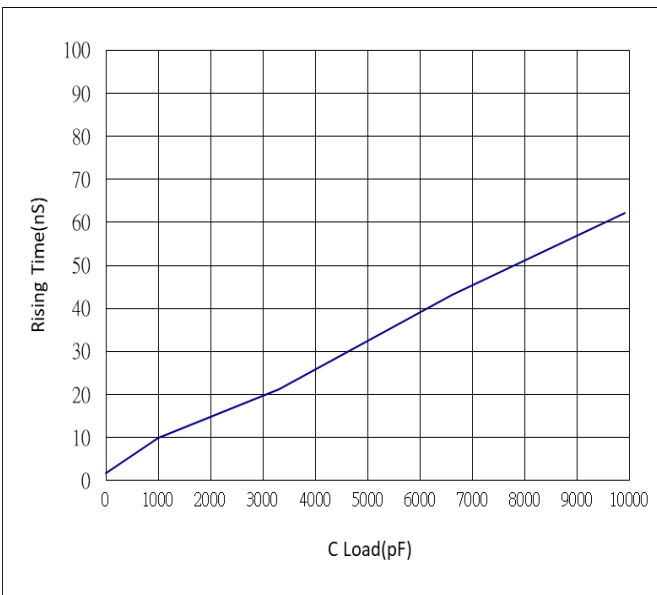
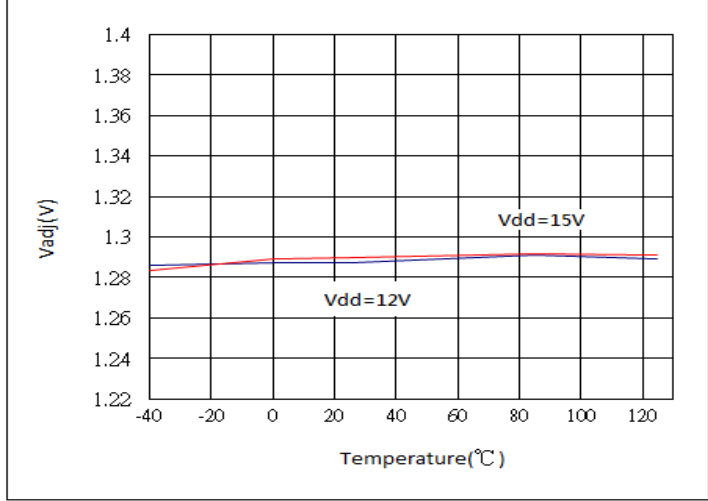
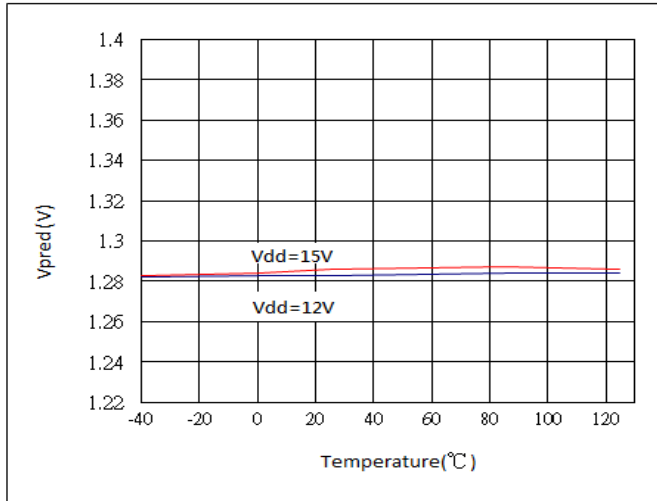
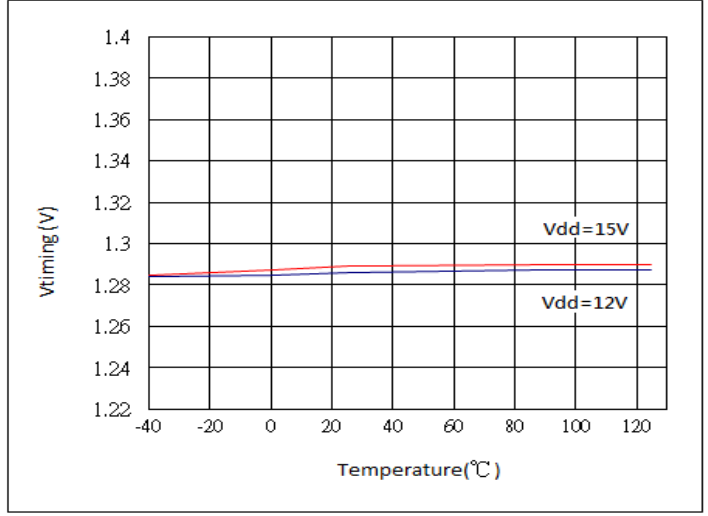
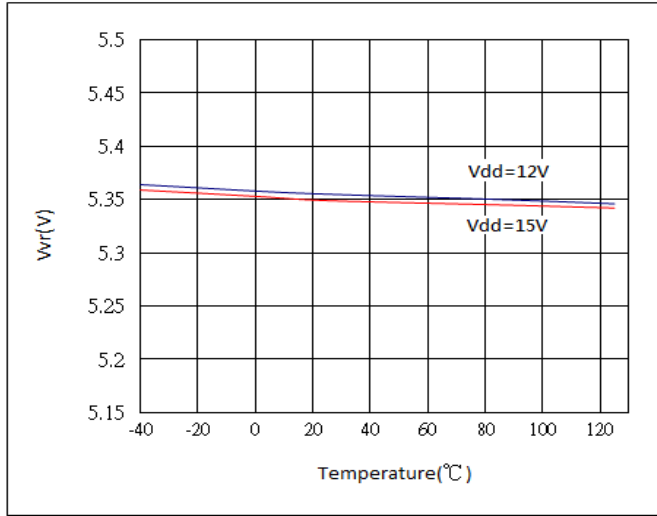



SP6015

Synchronous Rectifier Driver

PERFORMANCE CHARACTERISTICS ($T_A=25^\circ\text{C}$, unless otherwise specified.)

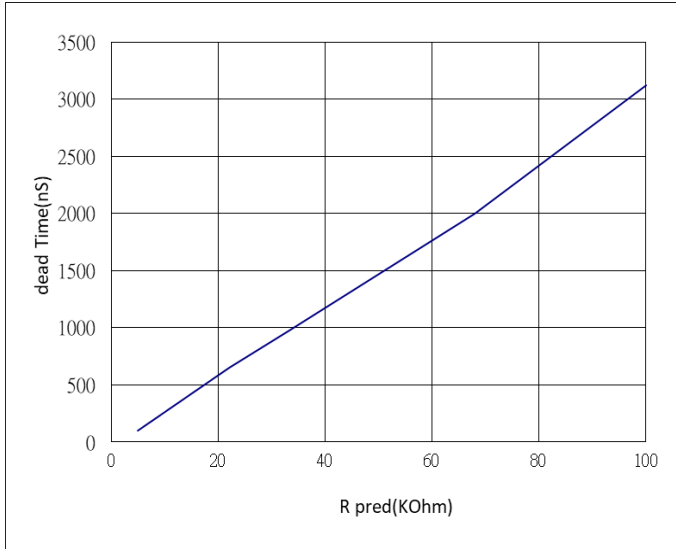



SP6015

Synchronous Rectifier Driver

Information provided is alleged to be exact and consistent. SYNC Power Corporation presumes no responsibility for the penalties of use of such information or for any violation of patents or other rights of third parties, which may result from its use. No license is granted by allegation or otherwise under any patent or patent rights of SYNC Power Corporation. Conditions mentioned in this publication are subject to change without notice. This publication surpasses and replaces all information previously supplied. SYNC Power Corporation products are not authorized for use as critical components in life support devices or systems without express written approval of SYNC Power Corporation.

© The SYNC Power logo is a registered trademark of SYNC Power Corporation

© 2020 SYNC Power Corporation – Printed in Taiwan – All Rights

Reserved SYNC Power Corporation

7F-2, No.3-1, Park Street

NanKang District (NKSP), Taipei, Taiwan, 115,

R.O.C Phone: 886-2-2655-8178

Fax: 886-2-2655-8468

<http://www.syncpower.com>