



SP6016D

Synchronous Rectifier Driver

DESCRIPTION

The fundamental of SP6016D synchronous rectifier (SR) driver IC is based on our U.S. patented methods that utilize the principle of “prediction” logic circuit. The IC deliberates previous cycle timing to control the SR in present cycle by “predictive” algorithm that makes adjustments to the turn-off time, in order to achieve maximum efficiency and avoid cross-conduction at the same time. Specially, SP6016D is designed for Resonance. It also maintains the MOSFET’s body diode conduction at minimum level. The SP6016D is capable to adapt in almost all existing Resonance converters with few adjustments considered necessary.

FEATURES

- Offers efficiency improvement over Schottky Diode
- Low Standby Power to meet DOE Lot 6 requirement.
- Drives all logic level Power MOSFET.
- Prediction gate timing control.
- Minimum MOSFET body diode conduction.
- Operating frequency up to 400 KHz.
- Synchronize to transformer secondary voltage waveform.
- Minimum on time 0.45us ~ 0.85us
- Internal 15KΩ resistor to GND at MOSG pin
- External timing pin to adjust the falling slope
- Internal over voltage protection

APPLICATIONS

- Switching Mode Power Supply
- Storage area network power supplies
- Telecommunication converters
- Embedded systems
- Industrial & commercial systems using high current processors
- Power converters to meet Lot 6 requirement

PIN CONFIGURATION (SOT-23-6L)

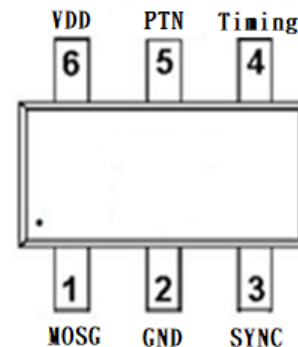

PART MARKING

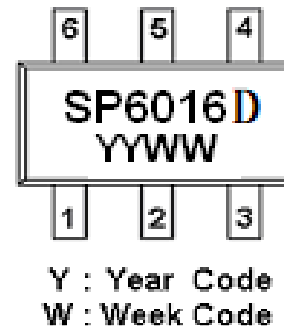



SP6016D

Synchronous Rectifier Driver

TYPICAL APPLICATION CIRCUIT

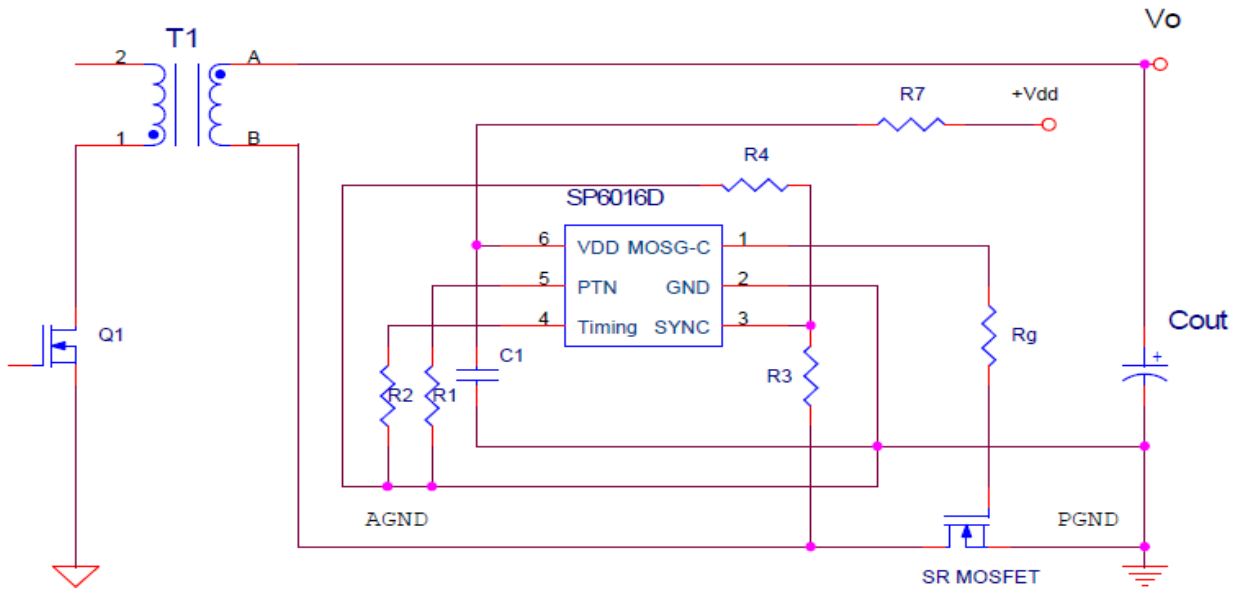

PIN DESCRIPTION

Pin	Symbol	Description
1	MOSG-C	Catch MOSFET gate drive.
2	GND	Ground connection.
3	SYNC	Synchronized signal from the VDS of SR MOSFET.
4	Timing	Discontinuous current filter timing adjustment resistor connection.
5	PTN	Connecting a resistor to ground to set the dead time and dynamic trigger point
6	Vdd	DC supply voltage.



SP6016D

Synchronous Rectifier Driver

BLOCK DIAGRAM

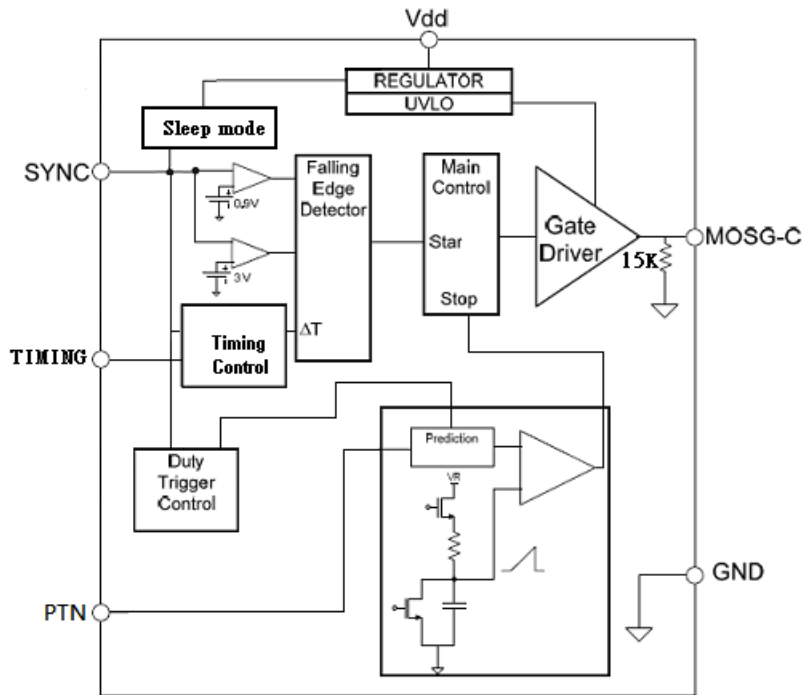

ORDERING INFORMATION

Part Number	Package	Part Marking
SP6016DS26RGB	SOT-23-6L	SP6016D

※ SP6016DS26RGB : Tape Reel ; Pb – Free ; Halogen - Free

ABSOLUTE MAXIMUM RATINGS (TA=25°C, unless otherwise specified.)

The following ratings designate persistent limits beyond which damage to the device may occur.

Symbol	Parameter	Value	Unit
V _{dd}	DC Supply Voltage	17	V
I _{OUT}	Peak Source Current (Pulsed)	1.0	A
	Peak Sink Current (Pulsed)	1.5	A
P _D	Power Dissipation @ T _A =85°C (*)	0.3	W
T _J	Operating Junction Temperature Range	-40 to 125	°C
T _{STG}	Storage Temperature Range	-40 to 150	°C
T _{LEAD}	Lead Soldering Temperature for 5 sec.	260	°C

THERMAL RESISTANCE

Symbol	Parameter	Value	Unit
R _{θJC}	Thermal Resistance Junction – Case (*)	110	°C/W

(*) The power dissipation and thermal resistance are evaluated under copper board mounted with free air conditions.



SP6016D

Synchronous Rectifier Driver

ELECTRICAL CHARACTERISTICS

($T_A=25^{\circ}\text{C}$, $V_{dd}=12\text{V}$, Freq. =50 KHz, Duty Cycle=50%, unless otherwise specified.)

Symbol	Parameter	Conditions	Min.	Typ.	Max.	Unit
SUPPLY INPUT						
IDD	Supply current	Sleep mode		0.15		mA
		$V_{\text{SYNC}}=V_{\text{dd}}$, Normal mode		3		mA
Vdd	Supply voltage	I _{dd peak} < 1A	4.5		16	V
Vdd on	Enable voltage			3.7	4.2	V
Vdd hysteresis	Enable voltage			0.3	0.5	V
Vovp	Over voltage protection		17	17.5	18.5	V
Vovp hysteresis			0.5	0.7	1	V
SYNC REFERENCE (SYNC)						
Vshth	SYNC high threshold			3.0		V
Vslth	SYNC low threshold			0.9		V
Vsync	SYNC clamp voltage	I _{sync} =3mA	V _{dd} +2.0			V
Vsync WK	SYNC wake-up voltage	Pulse width >1uS for V _{dd} =5V	7			V
Vsync WK	SYNC wake-up voltage	Pulse width >1uS for V _{dd} =12V	8.0			V
I _{sync}	SYNC input current				3	mA
REFERENCE Voltage (V_PTIN)						
V_PTIN				1.25		V
ON TIME DUTY SETUP (PIN 1)						
Ton-time		Frequency= 10KHz-20KHz, Duty=20%~50%		25		uS
MOSFET GATE DRIVER (MOSG-C)						
Voh	Output high voltage	I _o = -200mA		10.8		V
Vol	Output low voltage	I _o = 200mA		0.2		V
Td	Propagation delay	No load, R_PTIN=9.1KΩ		100		nS
Tpred	Dead time	No load, R_PTIN=9.1KΩ		230		nS
Tr	Rise time	Load = 1nF (*)		13		nS
Tf	Fall time	Load = 1nF (*)		7		nS
Dynamic Protect						
Dt	Dynamic variable	Pin 5=9.1KΩ		1100		nS
Ton-min	MOSG-C on time	PWM adjusts time > Dt	0.45		0.85	uS

(*) Tr & Tf are measured among 10% and 90% of starting and final voltage.

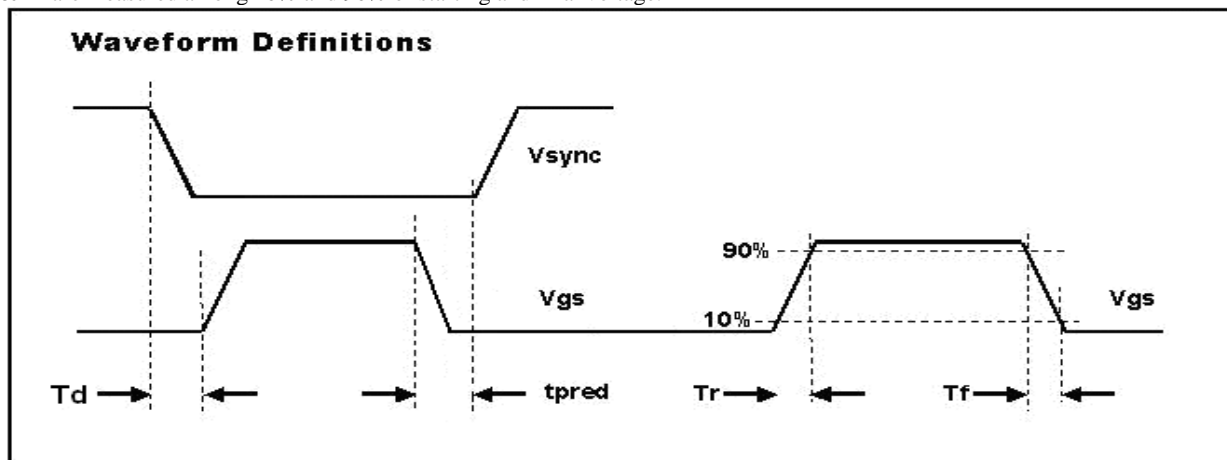



SP6016D

Synchronous Rectifier Driver

TYPICAL CHARACTERISTICS

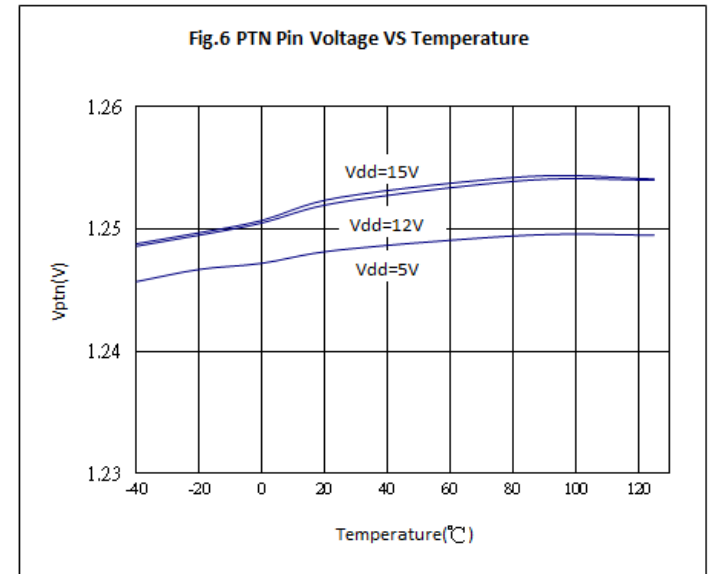
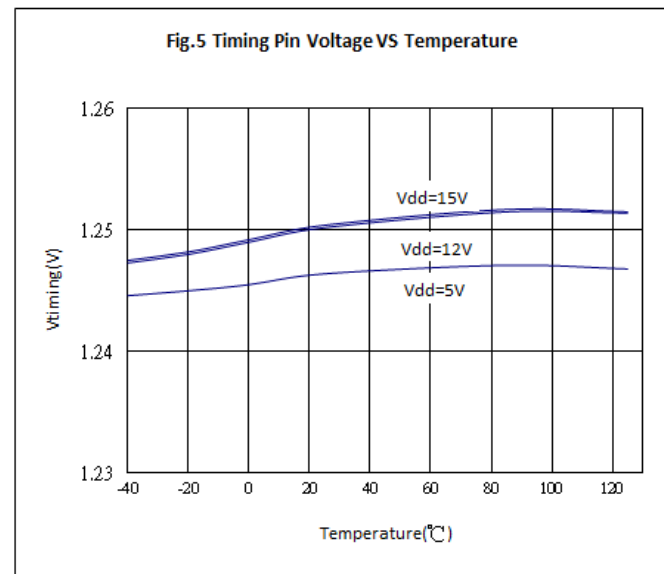
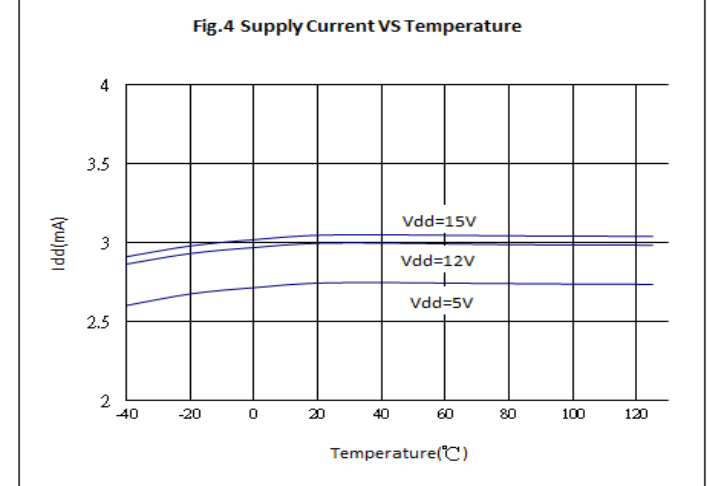
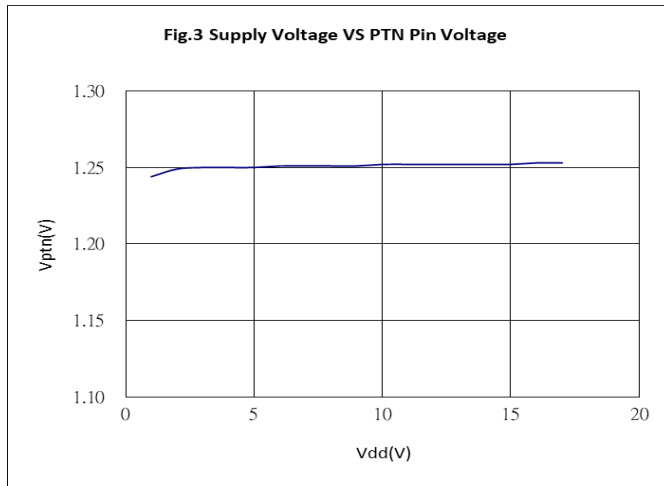
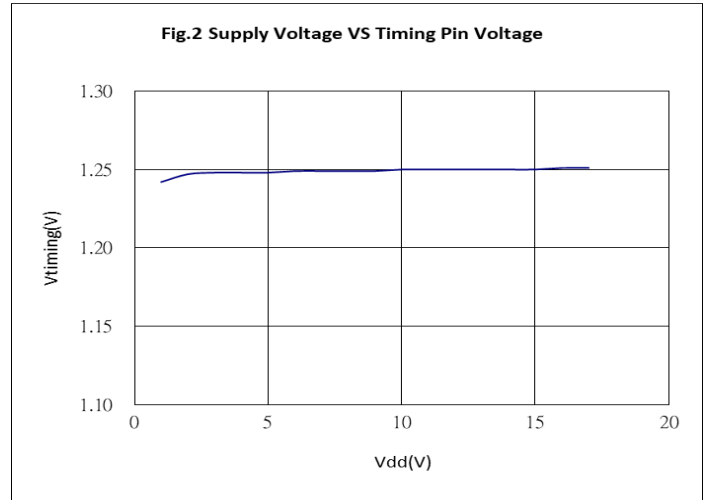
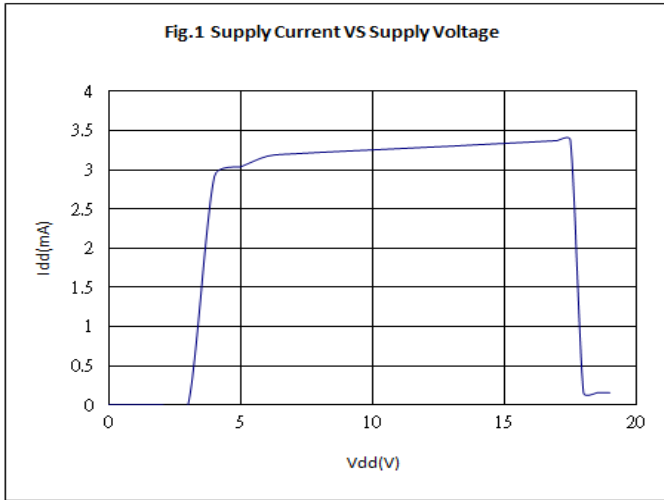



SP6016D

Synchronous Rectifier Driver

TYPICAL CHARACTERISTICS

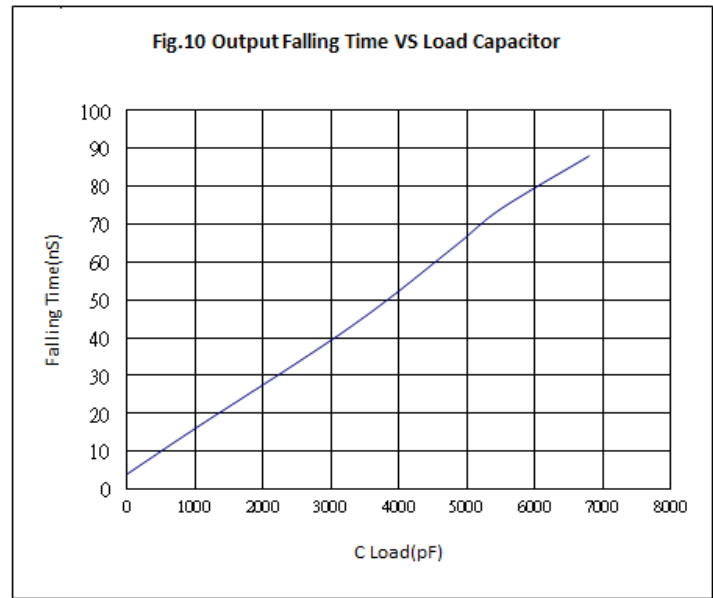
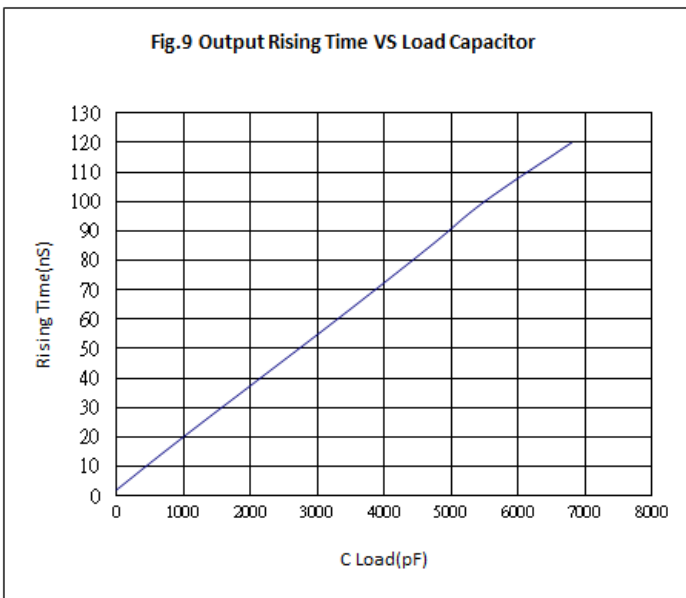
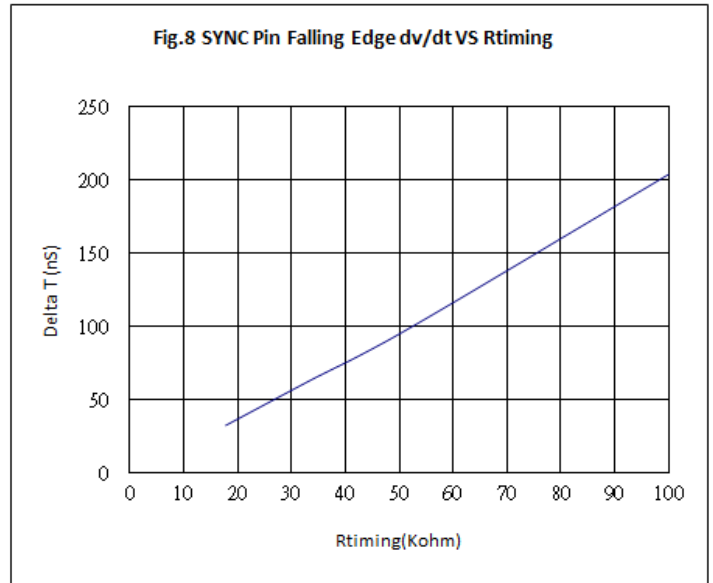
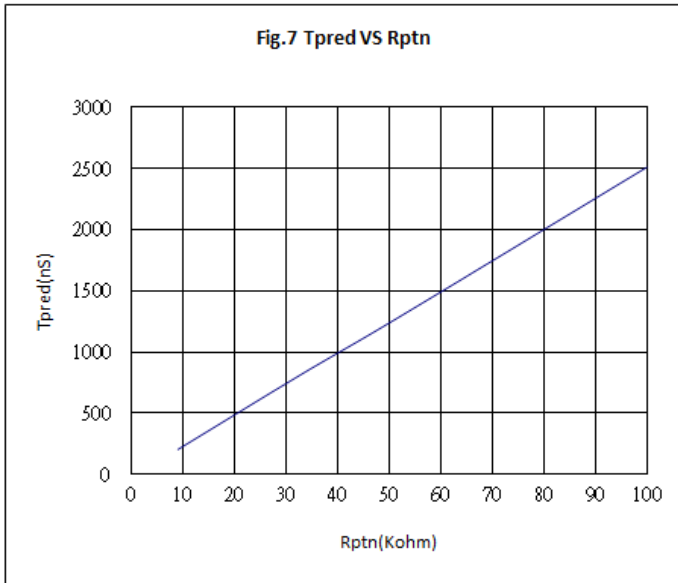



SP6016D

Synchronous Rectifier Driver

Information provided is alleged to be exact and consistent. SYNC Power Corporation presumes no responsibility for the penalties of use of such information or for any violation of patents or other rights of third parties, which may result from its use. No license is granted by allegation or otherwise under any patent or patent rights of SYNC Power Corporation. Conditions mentioned in this publication are subject to change without notice. This publication surpasses and replaces all information previously supplied. SYNC Power Corporation products are not authorized for use as critical components in life support devices or systems without express written approval of SYNC Power Corporation.

© The SYNC Power logo is a registered trademark of SYNC Power Corporation
© 2020 SYNC Power Corporation – Printed in Taiwan – All Rights Reserved

SYNC Power Corporation
7F-2, No.3-1, Park Street
NanKang District (NKSP), Taipei, Taiwan, 115,
R.O.C Phone: 886-2-2655-8178
Fax: 886-2-2655-8468
<http://www.syncpower.com>