



SP6018C

Synchronous Rectifier Driver

DESCRIPTION

The fundamental of SP6018C synchronous rectifier (SR) driver IC is based on our U.S. patented methods that utilize the principle of “prediction” logic circuit. The IC deliberates previous cycle timing to control the SR in present cycle by “predictive” algorithm that makes adjustments to the turn-off time, in order to achieve maximum efficiency and avoid cross-conduction at the same time. Specially, SP6018C is designed for Resonance. It also maintains the MOSFET’s body diode conduction at minimum level. The SP6018C is capable to adapt in almost all existing Resonance converters with few adjustments considered necessary.

FEATURES

- Offers efficiency improvement over Schottky Diode (depends on drive configuration of the SR).
- Drives all logic level Power MOSFET.
- Prediction gate timing control.
- Minimum MOSFET body diode conduction.
- Operating frequency up to 400 KHz.
- Synchronize to transformer secondary voltage waveform.

APPLICATIONS

- Servers & workstations
- Storage area network power supplies
- Telecommunication converters
- Embedded systems
- Industrial & commercial systems using high current processors

PIN CONFIGURATION (SOP-8)

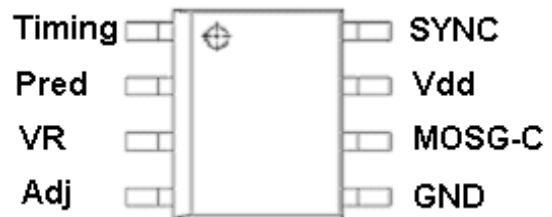

PART MARKING

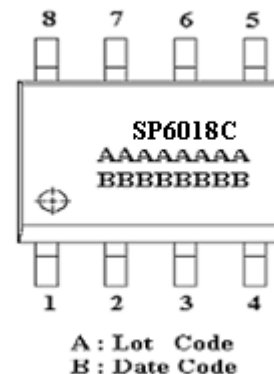



SP6018C

Synchronous Rectifier Driver

TYPICAL APPLICATION CIRCUIT

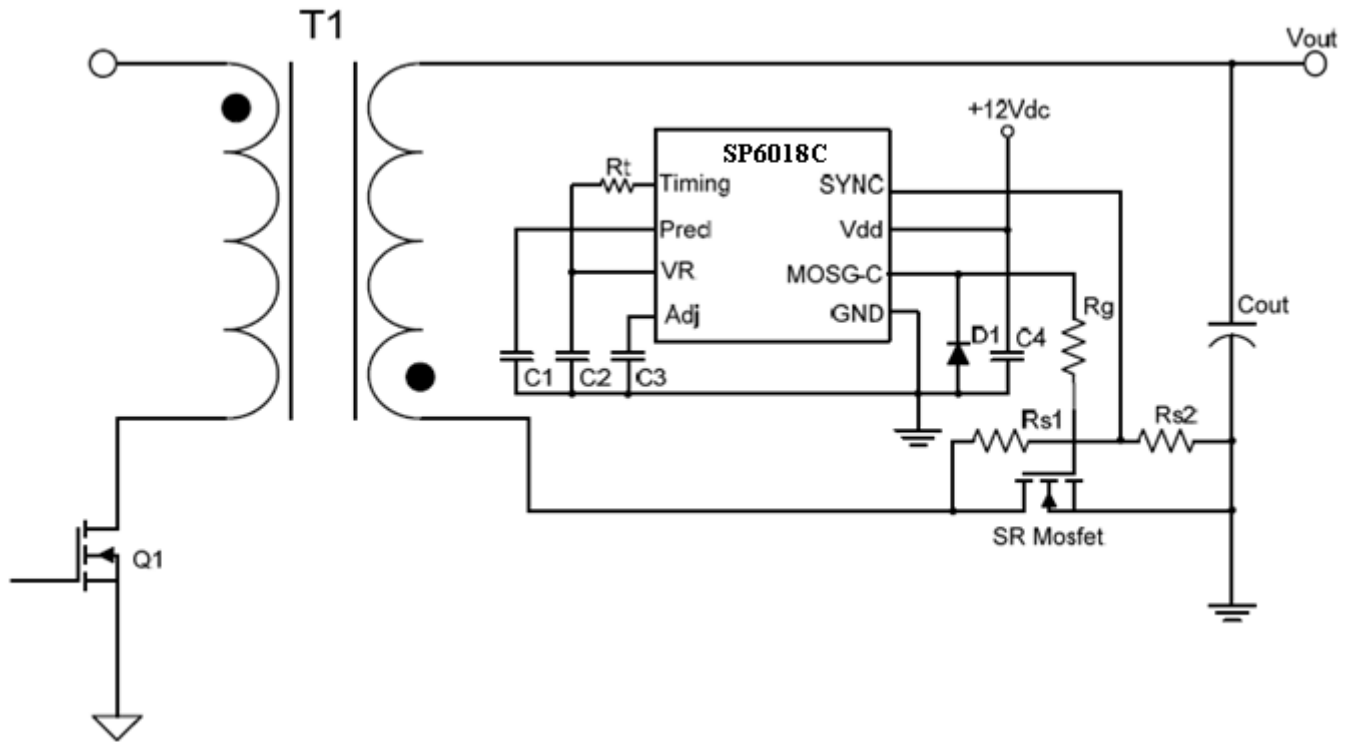

PIN DESCRIPTION

Pin	Symbol	Description
1	Timing	Discontinuous current filter timing adjustment resistor connection.
2	Pred	Capacitor to store previous cycle timing for SR MOSFET.
3	VR	Voltage Regulator.
4	Adj	Trigger point adjustment for Dynamic state.
5	GND	Ground connection.
6	MOSG-C	Catch MOSFET gate drive.
7	Vdd	DC supply voltage.
8	SYNC	Synchronized signal from the V_{DS} of SR MOSFET.



SP6018C

Synchronous Rectifier Driver

BLOCK DIAGRAM

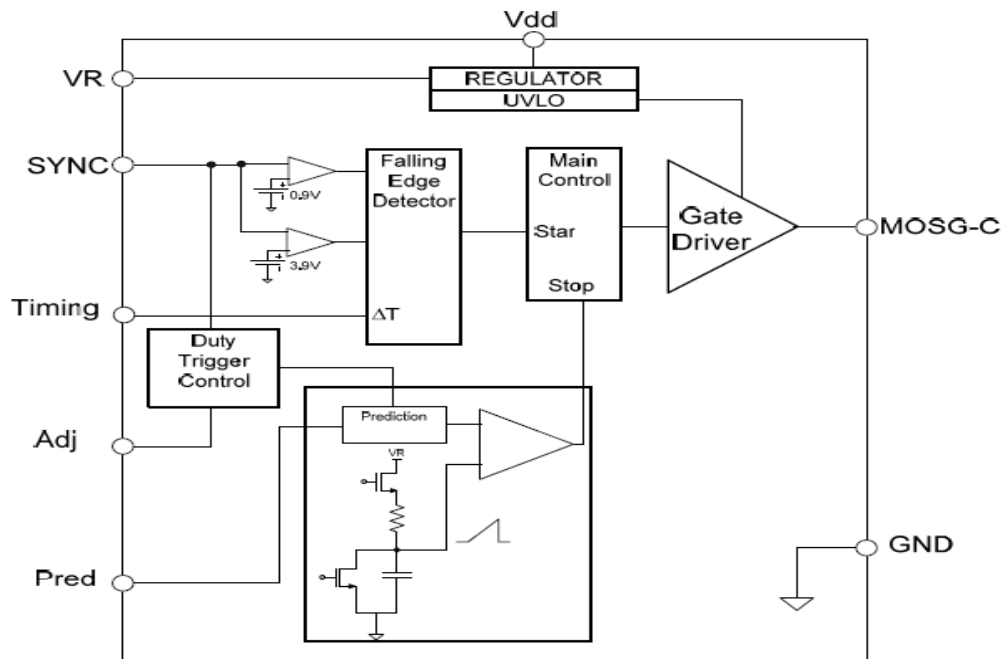

ORDERING INFORMATION

Part Number	Package	Part Marking
SP6018CS8RGB	SOP-8	SP6018C
SP6018CS8TGB	SOP-8	SP6018C

※ SP6018CS8RGB : 7" Tape Reel ; Pb – Free ; Halogen - Free

※ SP6018CS8TGB : Tube ; Pb – Free ; Halogen - Free

ABSOLUTE MAXIMUM RATINGS (TA=25°C, unless otherwise specified.)

The following ratings designate persistent limits beyond which damage to the device may occur.

Symbol	Parameter	Value	Unit
V _{dd}	DC Supply Voltage	16	V
I _{OUT}	Peak Source Current (Pulsed)	1.5	A
	Peak Sink Current (Pulsed)	1.5	A
P _D	Power Dissipation @ T _A =85°C (*)	0.25	W
T _J	Operating Junction Temperature Range	-25 to 105	°C
T _{STG}	Storage Temperature Range	-40 to 150	°C
T _{LEAD}	Lead Soldering Temperature for 5 sec.	260	°C

THERMAL RESISTANCE

Symbol	Parameter	Value	Unit
R _{θJC}	Thermal Resistance Junction – Case (*)	45	°C/W

(*) The power dissipation and thermal resistance are evaluated under copper board mounted with free air conditions.



SP6018C

Synchronous Rectifier Driver

ELECTRICAL CHARACTERISTICS

($T_A=25^{\circ}\text{C}$, $V_{dd}=12\text{V}$, Freq. =50 KHz, Duty Cycle=50%, unless otherwise specified.)

Symbol	Parameter	Conditions	Min.	Typ.	Max.	Unit
SUPPLY INPUT						
IDD	Supply current	No load		4	7.5	mA
		$V_{\text{SYNC}}=0\text{V}$, No load		5	8.5	mA
Vdd	Supply voltage	$I_{\text{dd peak}} < 1.5\text{A}$			16	V
Vdd on	Enable voltage		9.2	10.0	10.5	V
SYNC REFERENCE (SYNC)						
Vssth	SYNC high threshold		3.5	3.9		V
Vslth	SYNC low threshold			0.9	1.2	V
Vsync	SYNC clamp voltage	$I_{\text{sync}}=3\text{mA}$		5	7	V
Isync	SYNC input current				3	mA
Voltage Regulator REFERENCE (VR)						
Ivr	VR Output Current				20	mA
ON TIME DUTY SETUP (PIN 6)						
Ton-time				19	20	us
MOSFET GATE DRIVER (MOSG-C)						
Voh	Output high voltage	$I_o = -200\text{mA}$	10.5	11.0		V
Vol	Output low voltage	$I_o = 200\text{mA}$		0.5	0.8	V
Td	Propagation delay	No load	50	80		ns
Tpred		No load		120		ns
Tr	Rise time	Load = 1nF (*)		10	25	ns
Tf	Fall time	Load = 1nF (*)		10	25	ns
Dynamic Protect						
Dt	Dynamic variable	Pin 4 open		600		ns
Ton-min	MOSG-C on time	PWM adjusts time > Dt		1		us

(*) Tr & Tf are measured among 10% and 90% of starting and final voltage.

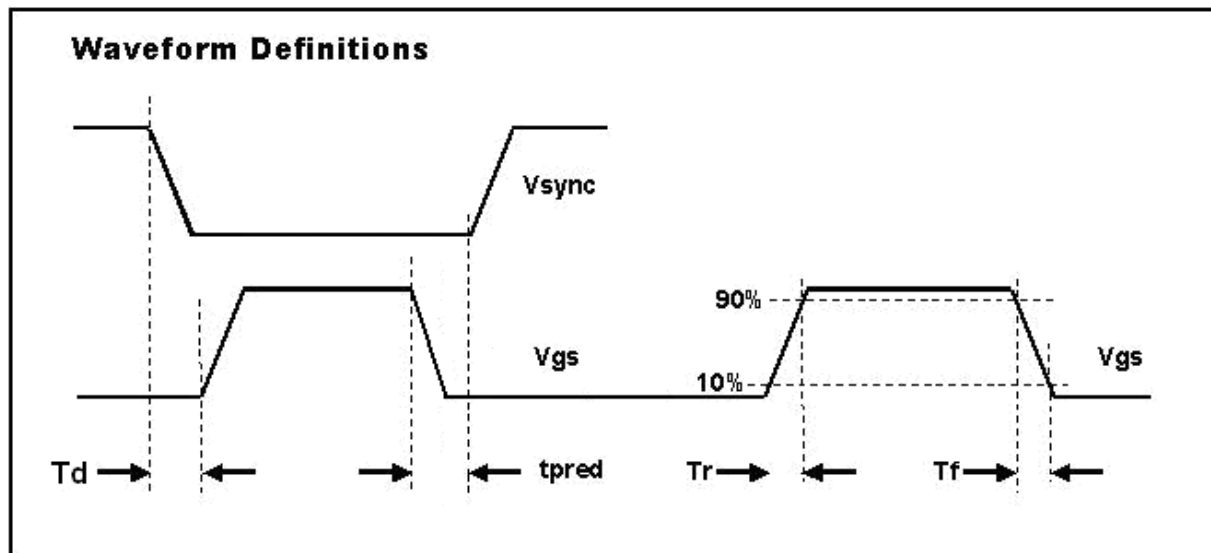



SP6018C

Synchronous Rectifier Driver

PERFORMANCE CHARACTERISTICS (T_A=25°C, unless otherwise specified.)

Figure 1 : Supply Current vs Supply Voltage

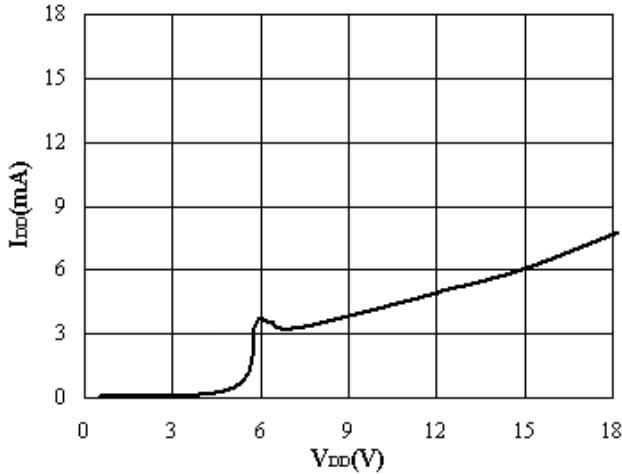

Figure 2 : Supply Current vs Freq. @ No Load

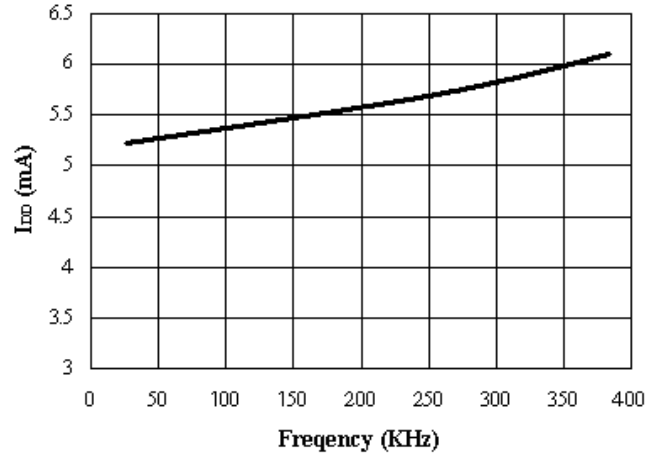

Figure 3 : T_{pred} vs C_{pred} @ Freq =100 KHz ; V_{DD} =10V

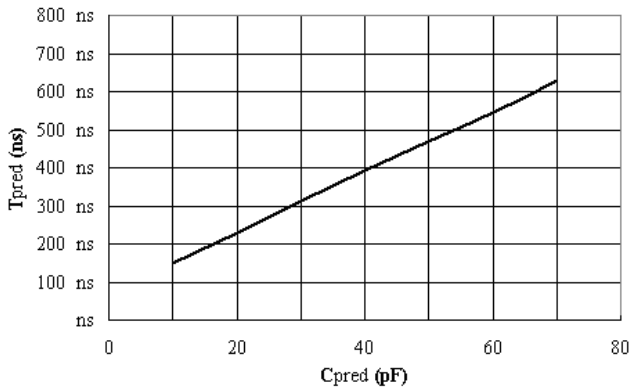

Figure 4 : Output Rise Time vs Load Capacitor

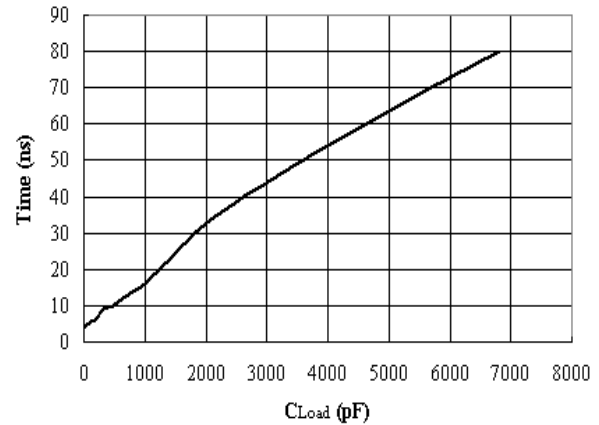

Figure 5 : Output Fall Time vs Load Capacitor

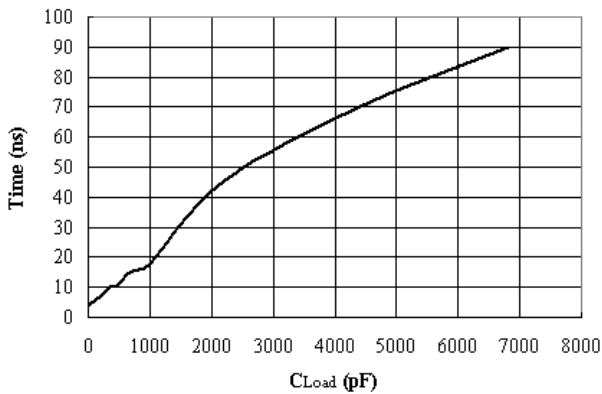
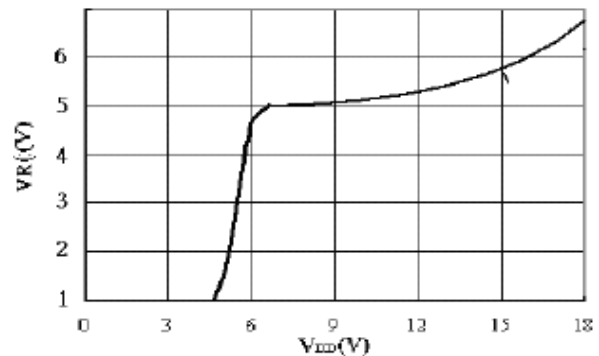

Figure 6 : VR Voltage vs Supply Voltage



*Fig. 1 : No Load ; No SYNC

*Fig. 4~5 : Frequency = 65 kHz.



SP6018C

Synchronous Rectifier Driver

Information provided is alleged to be exact and consistent. SYNC Power Corporation presumes no responsibility for the penalties of use of such information or for any violation of patents or other rights of third parties, which may result from its use. No license is granted by allegation or otherwise under any patent or patent rights of SYNC Power Corporation. Conditions mentioned in this publication are subject to change without notice. This publication surpasses and replaces all information previously supplied. SYNC Power Corporation products are not authorized for use as critical components in life support devices or systems without express written approval of SYNC Power Corporation.

© The SYNC Power logo is a registered trademark of SYNC Power Corporation

© 2020 SYNC Power Corporation – Printed in Taiwan – All Rights

Reserved SYNC Power Corporation

7F-2, No.3-1, Park Street

NanKang District (NKSP), Taipei, Taiwan, 115, R.O.C

Phone: 886-2-2655-8178

Fax: 886-2-2655-8468

<http://www.syncpower.com>