



N-Channel Enhancement Mode Field Effect Transistor

PRODUCT SUMMARY

V _{DSS}	I _D	R _{DS(ON)} (mΩ) Max
20V	32A	3.5 @ V _{GS} =4.5V
		3.7 @ V _{GS} =4.0V
		3.9 @ V _{GS} =3.7V
		4.3 @ V _{GS} =3.1V
		5.0 @ V _{GS} =2.5V

FEATURES

- Super high dense cell design for low R_{DS(ON)}.
- Rugged and reliable.
- Surface Mount Package.
- ESD Protected.

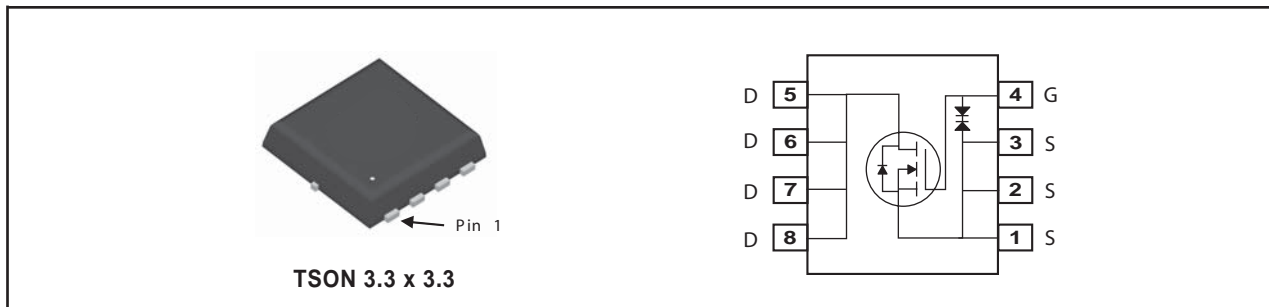

ABSOLUTE MAXIMUM RATINGS (T_A=25°C unless otherwise noted)

Symbol	Parameter	Limit	Units
V _{DS}	Drain-Source Voltage	20	V
V _{GS}	Gate-Source Voltage	±12	V
I _D	Drain Current-Continuous ^{a d}	T _A =25°C	32
		T _A =70°C	25.6
I _{DM}	-Pulsed ^b	96	A
P _D	Maximum Power Dissipation ^a	T _A =25°C	1.67
		T _A =70°C	1.07
T _J , T _{STG}	Operating Junction and Storage Temperature Range	-55 to 150	°C

THERMAL CHARACTERISTICS

R _{θJA}	Thermal Resistance, Junction-to-Ambient ^a	75	°C/W
------------------	--	----	------

SP8005

Ver 2.0

ELECTRICAL CHARACTERISTICS (T_A=25°C unless otherwise noted)

Symbol	Parameter	Conditions	Min	Typ	Max	Units
OFF CHARACTERISTICS						
BV _{bss}	Drain-Source Breakdown Voltage	V _{GS} =0V , I _D =250uA	20			V
I _{DSS}	Zero Gate Voltage Drain Current	V _{DS} =16V , V _{GS} =0V			1	uA
I _{GSS}	Gate-Body Leakage Current	V _{GS} = ±12V , V _{DS} =0V			±10	uA
ON CHARACTERISTICS						
V _{GS(th)}	Gate Threshold Voltage	V _{DS} =V _{GS} , I _D =1.0mA	0.5	1.1	1.5	V
R _{DS(ON)}	Drain-Source On-State Resistance	V _{GS} =4.5V , I _D =16A	2.3	2.8	3.5	m ohm
		V _{GS} =4.0V , I _D =16A	2.5	3.0	3.7	m ohm
		V _{GS} =3.7V , I _D =16A	2.6	3.1	3.9	m ohm
		V _{GS} =3.1V , I _D =16A	2.8	3.3	4.3	m ohm
		V _{GS} =2.5V , I _D =16A	3.0	3.5	5.0	m ohm
g _{FS}	Forward Transconductance	V _{DS} =5V , I _D =16A		56		S
DYNAMIC CHARACTERISTICS ^c						
C _{ISS}	Input Capacitance	V _{DS} =10V, V _{GS} =0V f=1.0MHz		2550		pF
C _{OSS}	Output Capacitance			528		pF
C _{RSS}	Reverse Transfer Capacitance			470		pF
SWITCHING CHARACTERISTICS ^c						
t _{D(ON)}	Turn-On Delay Time	V _{DD} =16V I _D =16A		62		ns
t _r	Rise Time			174		ns
t _{D(OFF)}	Turn-Off Delay Time	V _{GS} =4.5V R _{GEN} = 6 ohm		138		ns
t _f	Fall Time			73		ns
Q _g	Total Gate Charge	V _{DS} =16V, I _D =32A, V _{GS} =4.5V		30		nC
Q _{gs}	Gate-Source Charge			5.1		nC
Q _{gd}	Gate-Drain Charge			13.7		nC
DRAIN-SOURCE DIODE CHARACTERISTICS AND MAXIMUM RATINGS						
V _{SD}	Diode Forward Voltage	V _{GS} =0V, I _S =32A		0.85	1.2	V
Notes						
a.Surface Mounted on FR4 Board, t ≤ 10sec.						
b.Pulse Test:Pulse Width < 10us, Duty Cycle < 1%.						
c.Guaranteed by design, not subject to production testing.						
d.Drain current limited by maximum juncting temperature.						

Sep,13,2013

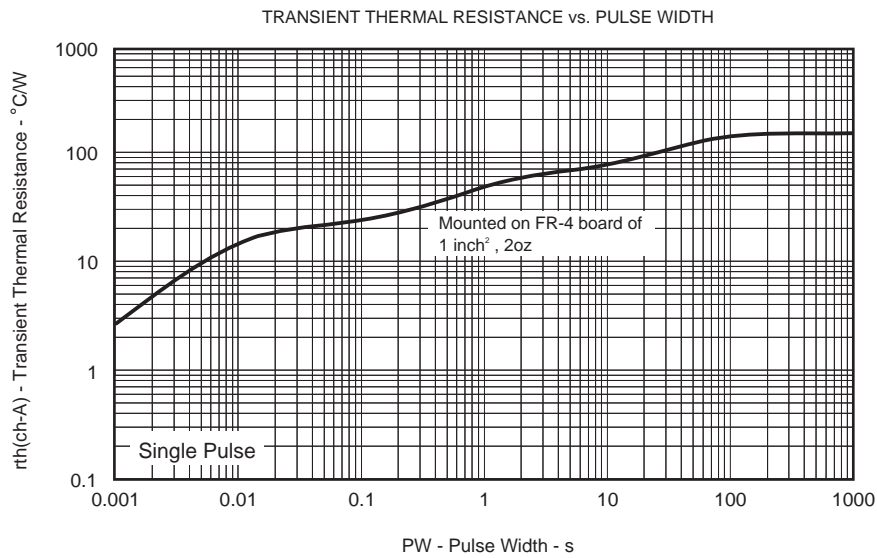
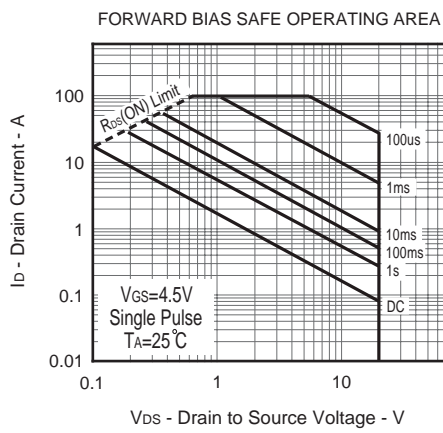
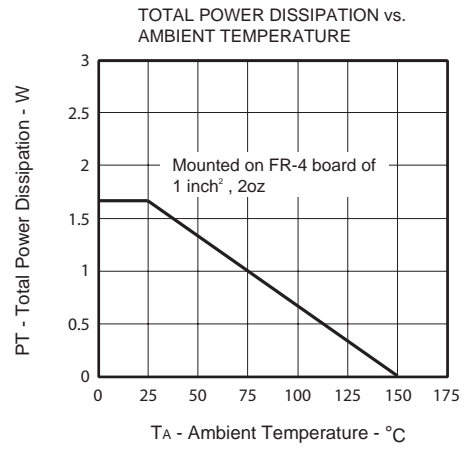
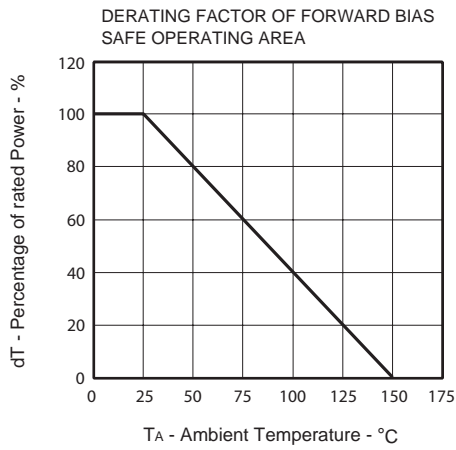

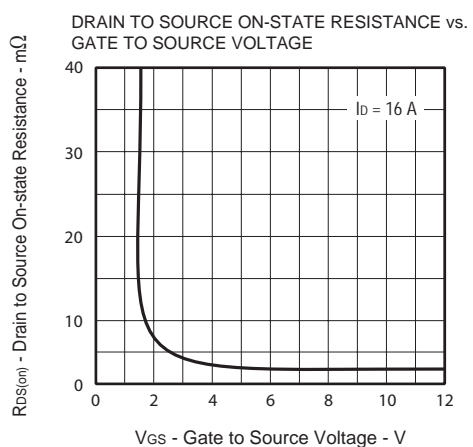
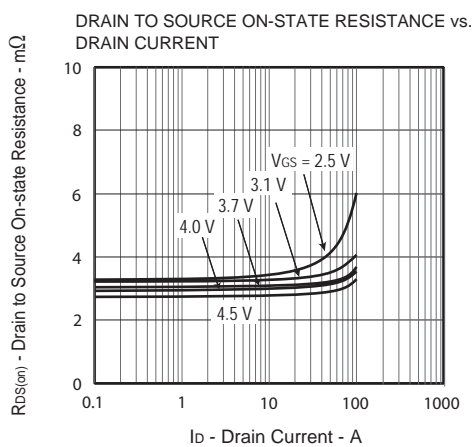
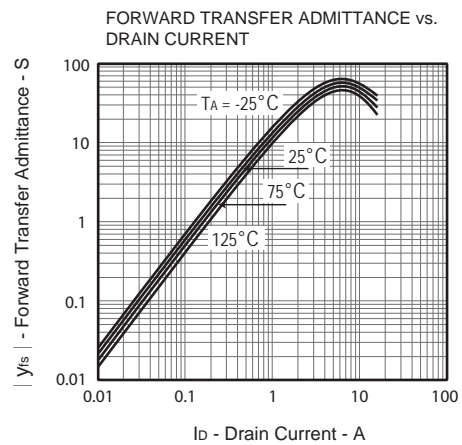
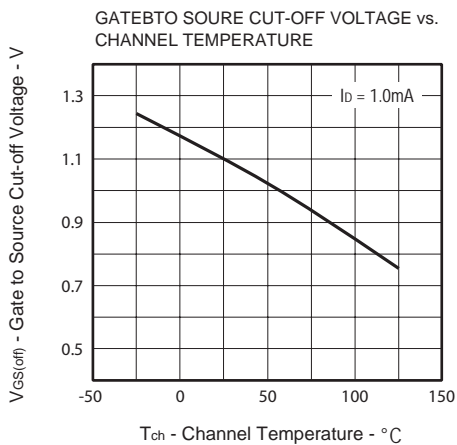
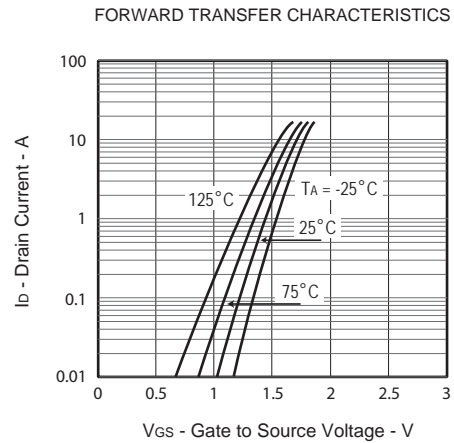
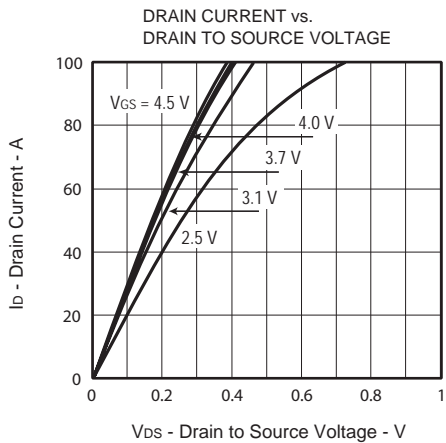

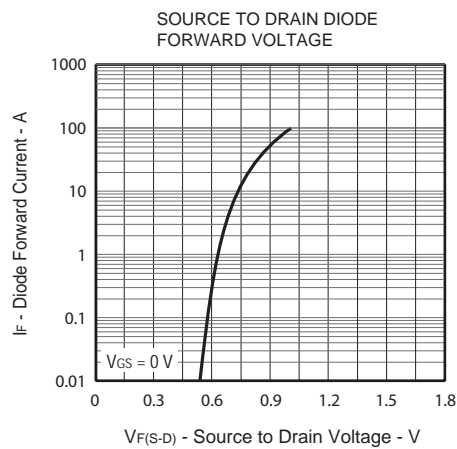
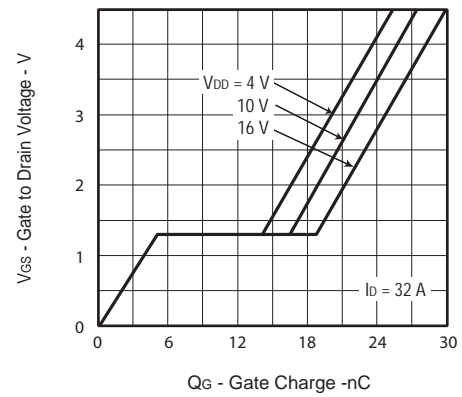
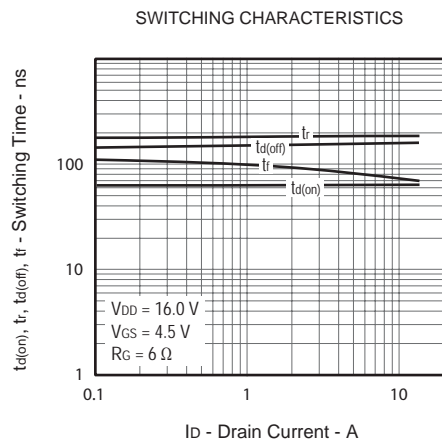
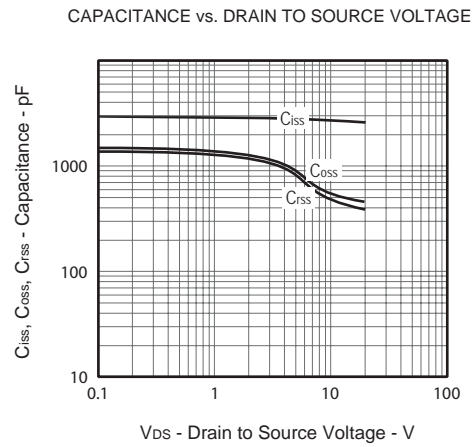
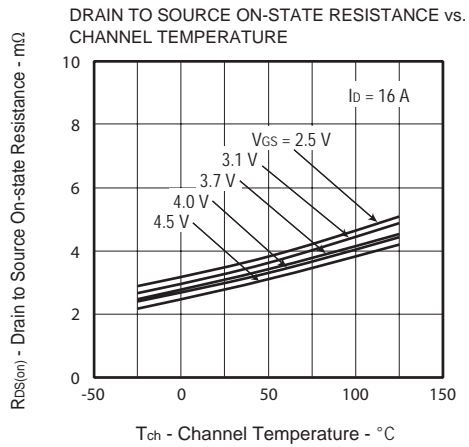

PACKAGE OUTLINE DIMENSIONS

TSON 3.3 x 3.3

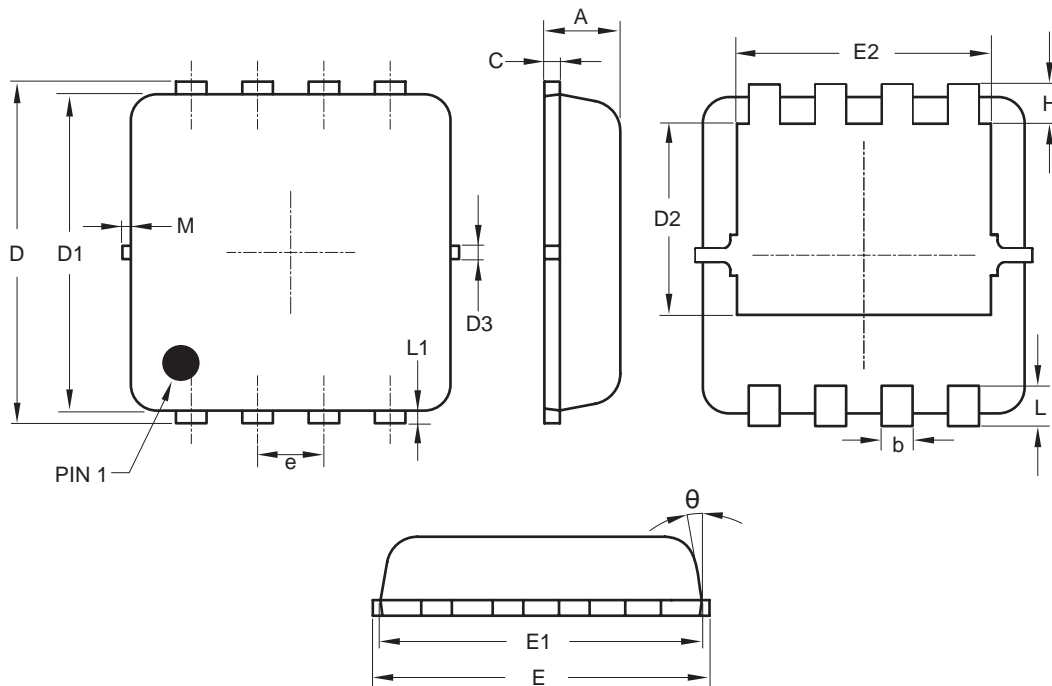

SYMBOLS	MILLIMETERS		
	MIN.	NOM.	MAX.
A	0.70	0.75	0.80
b	0.25	0.30	0.35
C	0.10	0.15	0.25
D	3.25	3.35	3.45
D1	3.00	3.10	3.20
D2	1.78	1.88	1.98
D3	—	0.13	—
E	3.20	3.30	3.40
E1	3.00	3.15	3.20
E2	2.39	2.49	2.59
e	0.65 BSC		
H	0.30	0.39	0.50
L	0.30	0.40	0.50
L1	—	0.13	—
M	—	—	0.15
θ	—	10°	12°

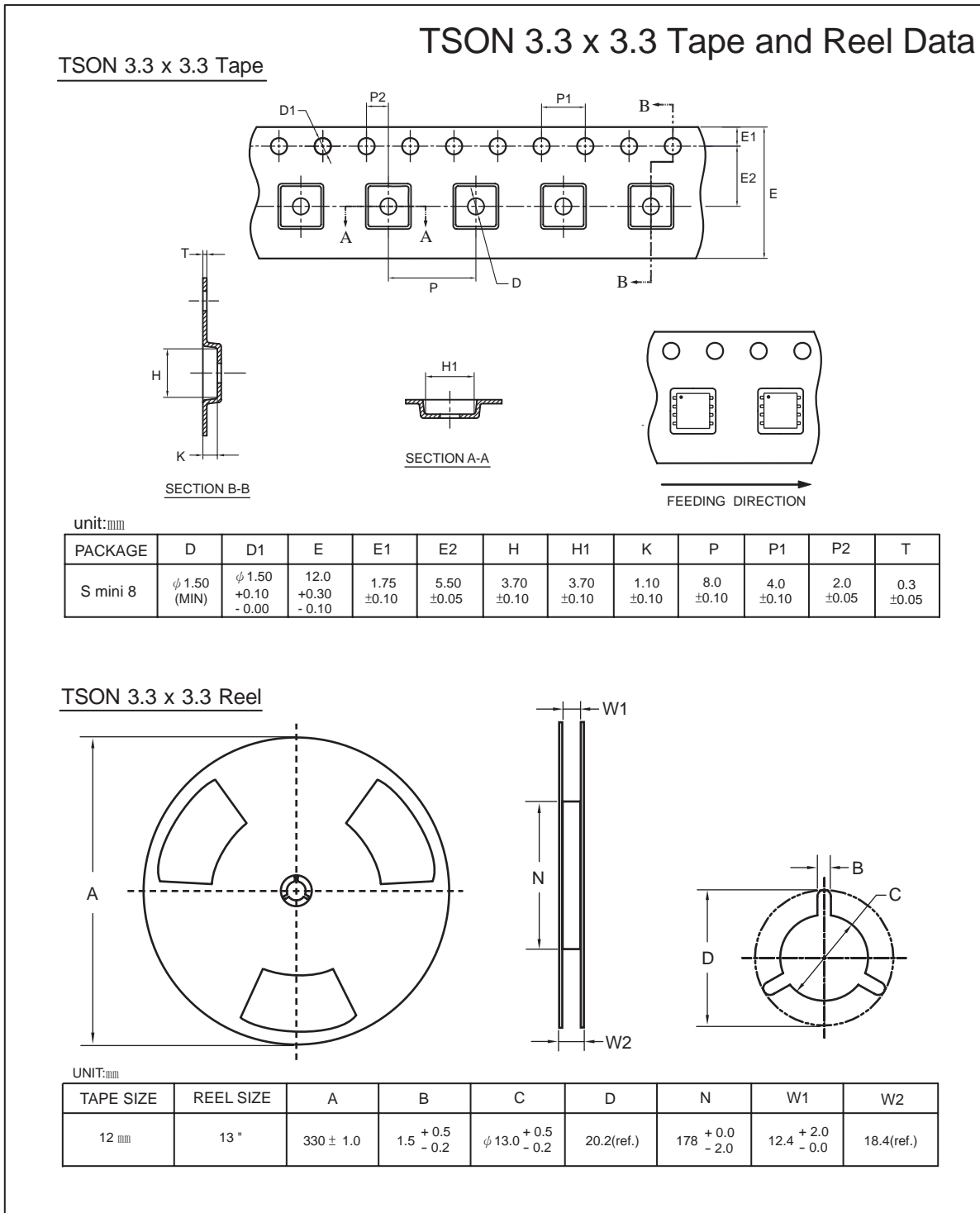

TOP MARKING DEFINITION

