

1. Package Dimension

(S22)

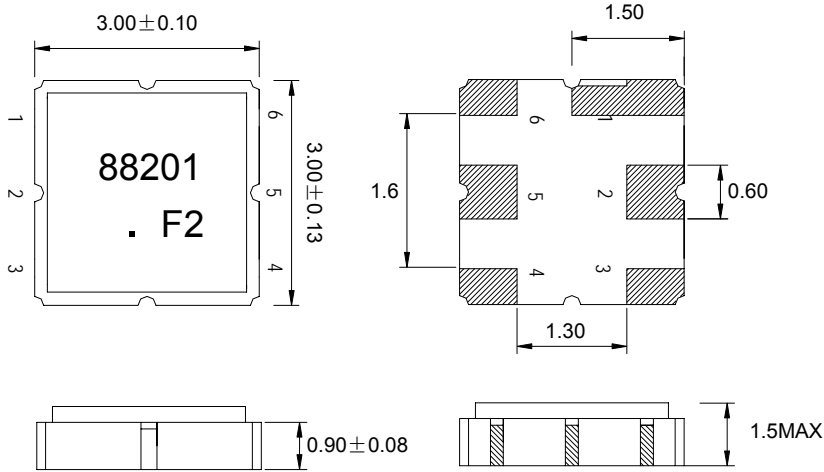

Unit: mm

Pin No.	Function
1.	Ground
2.	Signal
3.	Ground
4.	Ground
5.	Signal
6.	Ground

2. Marking

88201

Part Number

(1) Ink Marking or Laser Marking

(2) 01: Model code

(3) ∴ Pin 1 Identifier

(4) F2: Date code

.F2

F
Month code

2
Last figure of year

Month	1	2	3	4	5	6	7	8	9	10	11	12
Month code	A	B	C	D	E	F	G	H	I	J	K	L

e.g.: " F2" means June of 2002

	SIPAT Co., Ltd. (CETC No. 26 Research Institute) Nanping Huayuan Road No. 14 Chongqing, China, 400060	Part Number	SP88201	
		Rev. Date	2006-8-9	
		Rev.	1.0	Page

3. Performance

3.1 Application

RF SAW filter for cellular telephone.
Center frequency: 881.5MHz

3.2 Maximum Rating

Operation Temperature Range	-30°C to +80°C
Storage Temperature Range	-40°C to +85°C
DC Permissive Voltage	10V DC max.
Maximum Input Power	23 dBm

3.3 Electronic Characteristics

Item	Frequency (MHz)	Specification
Center Frequency (fo)	881.5	
Pass-band Width	25	
Insertion Loss	869 ~ 894	3.0 dB max.
Pass-band Ripple	869 ~ 894	1.8 dB max.
Return Loss	869 ~ 894	10.0 dB min.
Stop-band Attenuation	DC ~ 800	20 dB min.
	824 ~ 849	35 dB min.
	978 ~ 1006	25 dB min.
	1088 ~ 1119	30 dB min.
	1119 ~ 2600	20 dB min.

	SIPAT Co., Ltd. (CETC No. 26 Research Institute) Nanping Huayuan Road No. 14 Chongqing, China, 400060	Part Number	SP88201	
		Rev. Date	2006-8-9	
		Rev.	1.0	Page

3.4 Frequency Characteristics

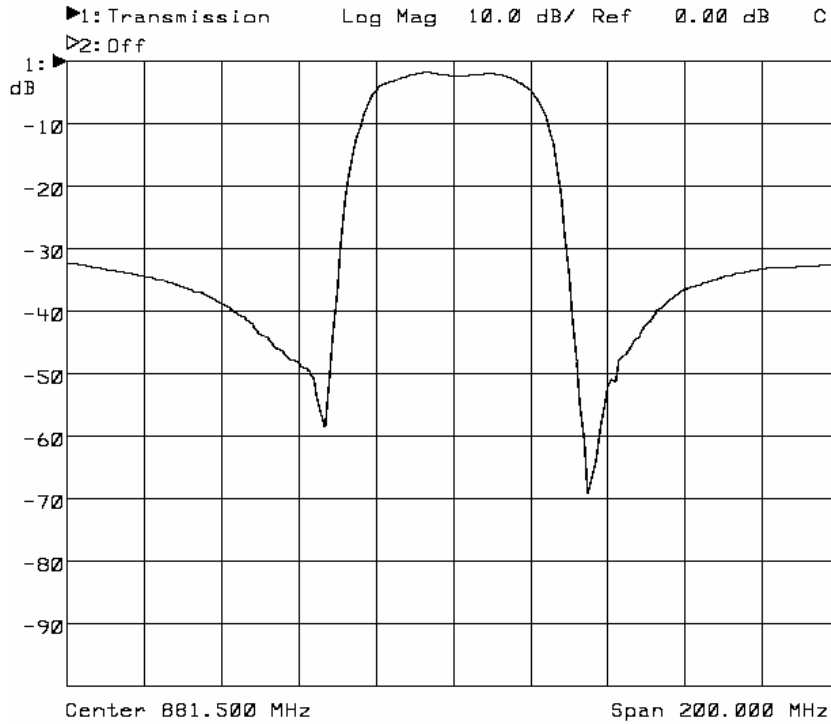

3.5 Test Circuit

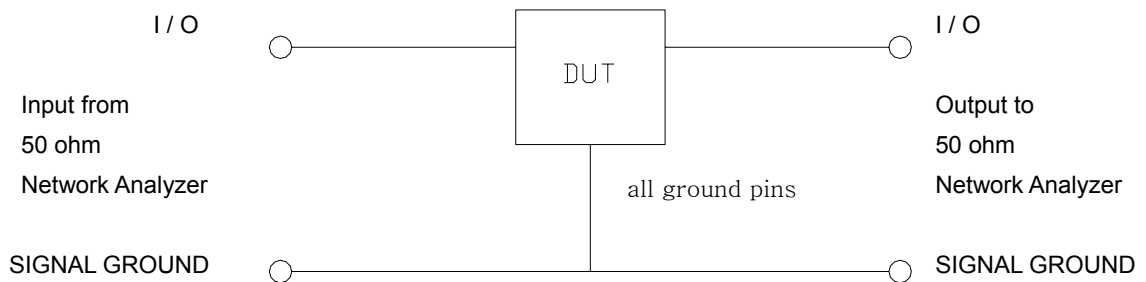

	SIPAT Co., Ltd. (CETC No. 26 Research Institute) Nanping Huayuan Road No. 14 Chongqing, China, 400060	Part Number	SP88201	
		Rev. Date	2006-8-9	
		Rev.	1.0	Page

4. Reliability

- 4.1 Mechanical Shock: The components shall remain within the electrical specifications after three one-half sine shock pulses(3000g's for 0.3 ms) in each direction(for six total) along each of the three mutually perpendicular axes for a total of 18 shocks.
- 4.2 Vibration Fatigue: The components shall remain within the electrical specifications after loaded vibration at 20~55Hz, amplitude 1.5mm, X,Y,Z, direction, for 2 hours.
- 4.3 Leak Test
 - 4.3.1 Gross Leak Test: Submerge samples into at +85°C water for at least 1 minute. Carefully observe the samples. No bubbles should be seen.
 - 4.3.2 Fine Leak Test: Expose samples for testing to 60 PSIG Helium gas for 2 hours. Then transfer the same samples to another chamber and draw a vacuum. Measure the leak rate. Failure is defined if the leak rate exceeds 5×10^{-8} atm cc/sec Helium.
- 4.4 High Temperature Storage: The components shall remain within the electrical specifications after being kept at the $85^{\circ}\text{C} \pm 2^{\circ}\text{C}$ for 960 hours, then kept at room temperature for 2 hours.
- 4.5 Low Temperature Storage: The components shall remain within the electrical specifications after being kept at the $-40^{\circ}\text{C} \pm 2^{\circ}\text{C}$ for 960 hours, then kept at room temperature for 2 hours.
- 4.6 Temperature Cycle: The components shall remain within the electrical specification after 32 cycles of high and low temperature testing (one cycle: 80°C for 30 minutes \rightarrow 25°C for 20 seconds \rightarrow -40°C for 30 minutes) than kept at room temperature for 2 hours.
- 4.7 Humidity Test: The components shall remain within the electrical specifications after being kept at the condition of ambient temperature 70°C , and 90~95% RH for 240 hours, then kept at room temperature and normal humidity for 4 hours.
- 4.8 Solder-heat Resistance: The components shall remain within the electrical specifications after dipped in the solder at $260^{\circ}\text{C} \pm 5^{\circ}\text{C}$ for 10 to 11 seconds, then kept at room temperature for 10 minutes.
- 4.9 Solderability: Solderability of terminal shall be kept at more than 80% after dipped in the solder flux at $230^{\circ}\text{C} \pm 5^{\circ}\text{C}$ for 5 ± 1 seconds.
- 4.10 Storage: The components shall meet the electrical and mechanical specifications after 5 years storage, if stored within the temperature range of $-40^{\circ}\text{C} \sim +85^{\circ}\text{C}$ and in the humidity of 20 to 60% r.h.

5. Remarks

5.1 Static voltage

Static voltage between signal load & ground may cause deterioration & destruction of the component. Please avoid static voltage.

	SIPAT Co., Ltd. (CETC No. 26 Research Institute) Nanping Huayuan Road No. 14 Chongqing, China, 400060	Part Number	SP88201	
		Rev. Date	2006-8-9	
		Rev.	1.0	Page

5.2 Ultrasonic cleaning

Ultrasonic vibration may cause deterioration & destruction of the component. Please avoid ultrasonic cleaning.

5.3 Soldering

Only leads of component may be soldered. Please avoid soldering another part of component.

6. Packing

6.1 Dimensions

- (1) Carrier Tape: Figure 1
- (2) Reel: Figure 2
- (3) The product shall be packed properly not to be damaged during transportation and storage.

6.2 Reeling Quantity

3,000pcs/reel

6.3 Taping Structure

- (1) The tape shall be wound around the reel in the direction shown below.

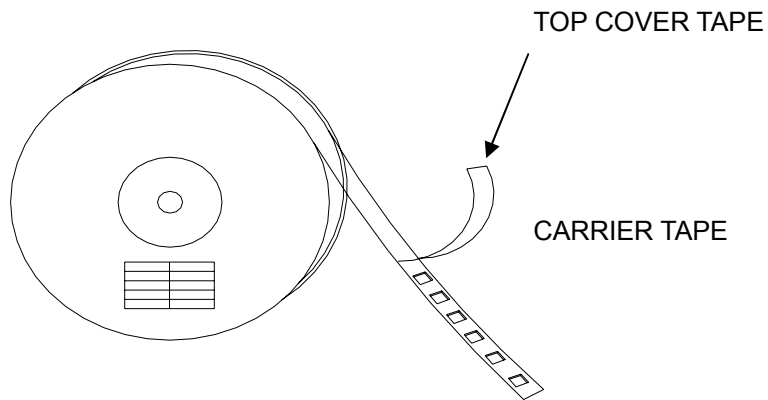

(2) Lable

Device Name	
Type	
Quantity	
Lot No.	

	SIPAT Co., Ltd. (CETC No. 26 Research Institute) Nanping Huayuan Road No. 14 Chongqing, China, 400060	Part Number	SP88201	
		Rev. Date	2006-8-9	
		Rev.	1.0	Page

(2) Leader part and vacant position specifications.

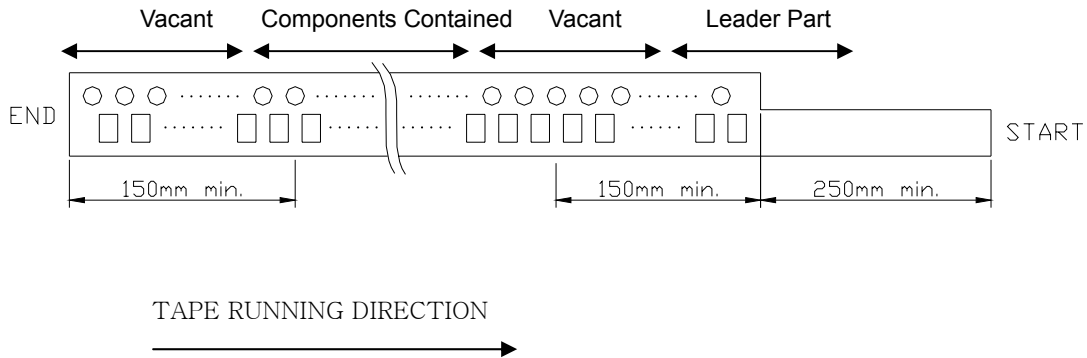

7. Tape Specifications

7.1 Tensile Strength of Carrier Tape: 4.4N/mm width

7.2 Top Cover Tape Adhesion (See the below figure)

- (1) pull off angle: 0~15°
- (2) speed: 300mm/min.
- (3) force: 20~70g

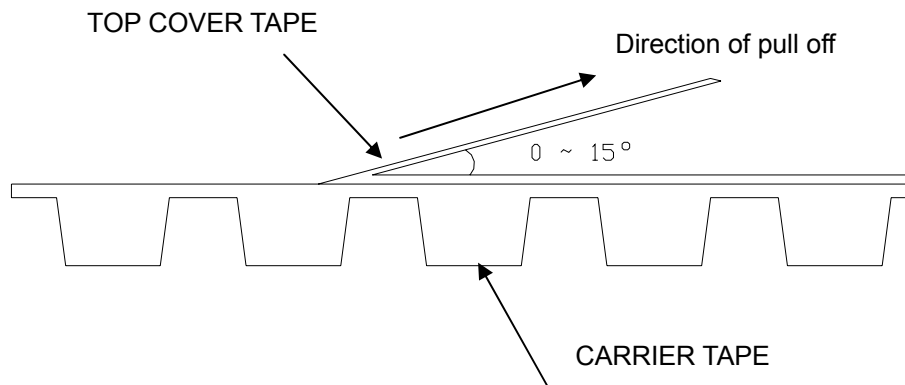

SIPAT Co., Ltd.
(CETC No. 26 Research Institute)
Nanping Huayuan Road No. 14
Chongqing, China, 400060

Part Number	SP88201	
Rev. Date	2006-8-9	
Rev.	1.0	Page 6/8

[Figure 1] Carrier Tape Dimensions

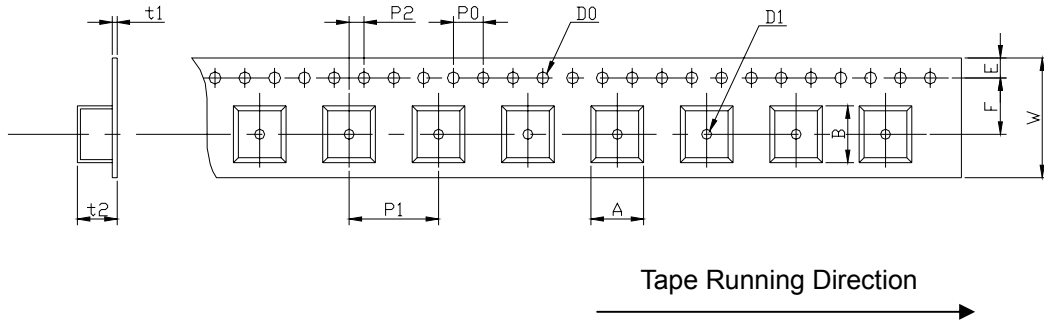

[Unit: mm]

W	F	E	P0	P1	P2	D0	D1	t1	t2	A	B
12.0	5.5	1.75	4.0	4.0	2.0	$\Phi 1.5$	$\Phi 1.5$	0.31	1.95	3.3	3.3
± 0.3	± 0.1	± 0.1	± 0.2	± 0.1	± 0.2	± 0.1	± 0.25	max.	max.	max.	max.

[Figure 2] Reel Dimensions

[Unit: mm]

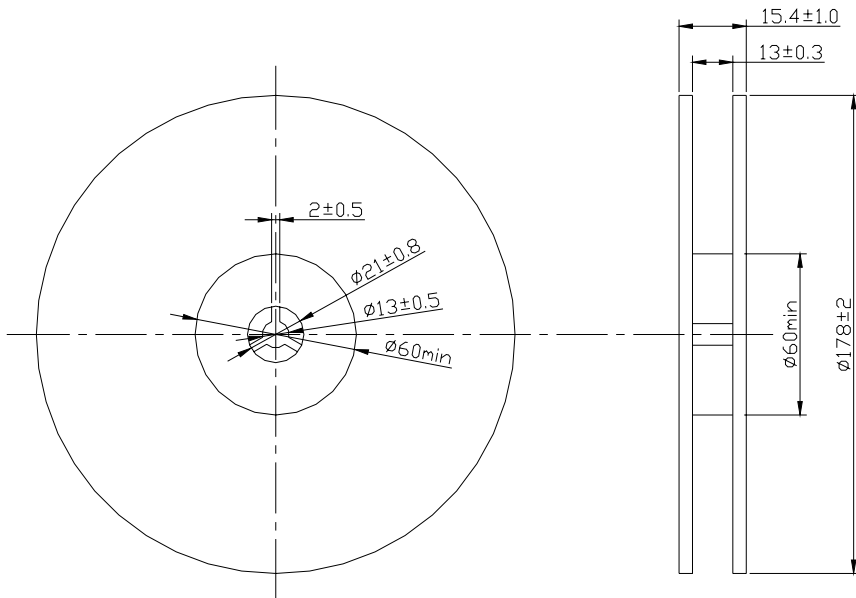

SIPAT Co., Ltd.
(CETC No. 26 Research Institute)
Nanping Huayuan Road No. 14
Chongqing, China, 400060

Part Number	SP88201	
Rev. Date	2006-8-9	
Rev.	1.0	Page 7/8

[Figure 3] Part Direction

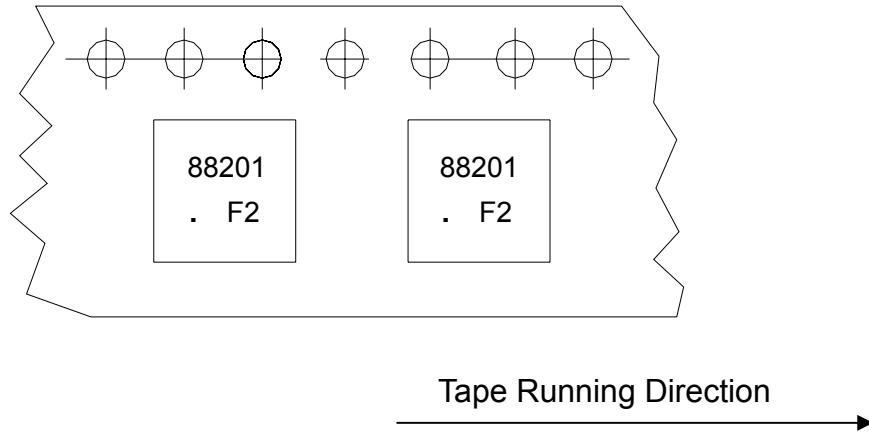

	SIPAT Co., Ltd. (CETC No. 26 Research Institute) Nanping Huayuan Road No. 14 Chongqing, China, 400060	Part Number	SP88201	
		Rev. Date	2006-8-9	
		Rev.	1.0	Page 8/8