



T-79-07-10

# SP92701

## SUB-NANOSECOND ECL LINE RECEIVER AND DRIVER

The SP92701 is designed with an on-chip reference to allow either single ended or differential ECL signals to be received. The inverted and non-inverted outputs can drive 50Ω lines directly.

The use of a fixed current source in the tail of the differential input stage, enables the device to be used in more general applications. These include operational amplifier applications where low propagation delays are required.

### FEATURES

- ECL 10K Compatible
- Single or Differential Operation
- 50 Ohm Line Driving Capability
- Sub-nanosecond Performance
- ECL Reference Output
- Operating Temperature -40°C to +85°C (DG)
- Full Static Protection on All Pins

### APPLICATIONS

- Line Receiver
- Line Driver
- Clock Buffering/Distribution
- Op-amp Circuits
- Fanout Expansion
- Schmitt Trigger Circuits
- Fast Peak Detector

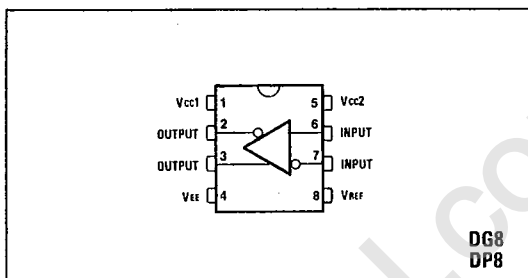

Fig.1 Pin connections - top view

### ORDERING INFORMATION

- SP92701C DP (Industrial - Plastic DIL package)
- SP92701B DG (Industrial - Ceramic DIL package)

### ABSOLUTE MAXIMUM RATINGS

Power supply voltage   Vcc-Vee	8V
Input voltage	0V to VEE
Differential input voltage	3.3V
Output source current	50mA
Storage temperature range	-55°C to 150°C
Junction operating temperature	
DG	175°C
DP	150°C

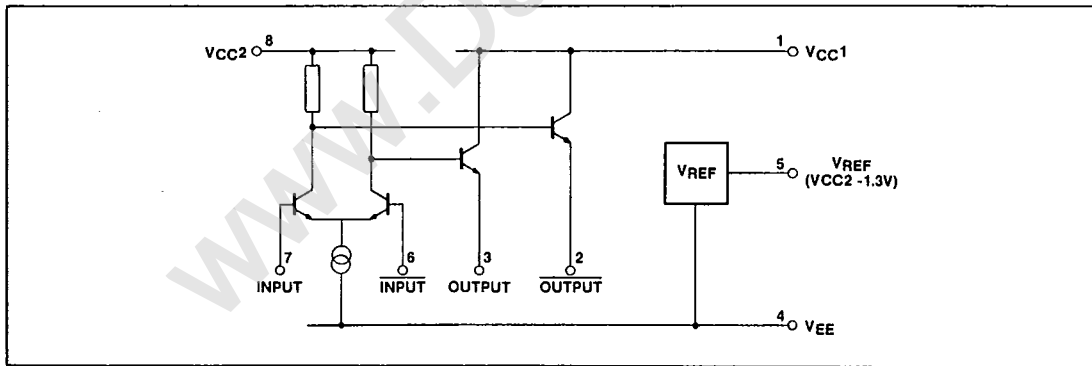

Fig.2 Internal diagram

SP92701

**ELECTRICAL CHARACTERISTICS**

T-79-07-10

Test conditions (unless otherwise stated):

$T_{amb}$  -40°C to +85°C (DG package), 0°C to +70°C (DP package);  $V_{EE} = -5.2V \pm 0.25V$

**DC Characteristics**

Characteristic	Symbol	Value						Units	Conditions
		-40°C (DG)		25°C (DP & DG)		85°C (DG)			
		Min.	Max.	Min.	Max.	Min.	Max.		
Power supply current	$I_{EE}$		12		12		12	mA	No load
Input current high	$I_{INH}$				350			$\mu A$	Inputs ECL high
Input leakage current	$I_{cbo}$				40		40	$\mu A$	Inputs ECL low
Reference voltage	$V_{REF}$	-1.43	-1.29	-1.35	-1.23	-1.29	-1.15	V	
High output voltage	$V_{OH}$	-1.06	-0.86	-0.96	-0.81	-0.89	-0.70	V	Load = 50Ω to -2V
Low output voltage	$V_{OL}$	-1.90	-1.66	-1.85	-1.62	-1.83	-1.57	V	Load = 50Ω to -2V
High input voltage	$V_{IH}$	-1.19	-0.88	-1.09	-0.81	-1.03	-0.7	V	
Low input voltage	$V_{IL}$	-1.90	-1.53	-1.85	-1.48	-1.83	-1.44	V	

Characteristic	Symbol	Value			Units	Conditions
		Min.	Typ.	Max.		
Common mode range	$V_{cmr}$		2.85 to 0.8		V	At 25°C
Input sensitivity (differential)	$V_{pp}$		150		mV	At 25°C
Differential gain			25		dB	At 25°C

**AC Characteristics**

$T_{amb} = 25^\circ C$

Characteristic	Symbol	Value			Units	Conditions
		Min.	Typ.	Max.		
Propagation delay	$t_{pd}$		0.8	0.96	ns	
Transition time, 20 % to 80 %	$t_r, t_f$		0.8	0.95	ns	

NOTE: Guaranteed but not tested.

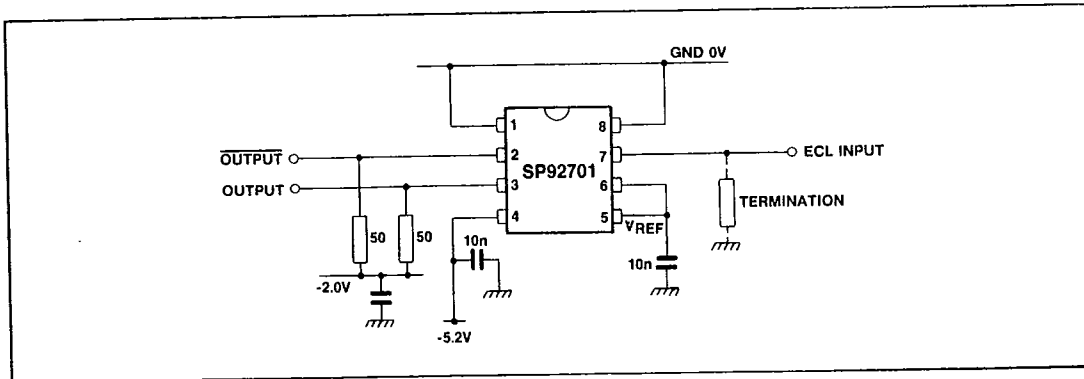

Fig.3 Test/applications circuit

T-79-07-10

**OPERATING NOTES**

The SP92701 has been designed primarily for enhancing the edges of ECL signals.

With most systems using ECL it is necessary to minimise the amount of edge jitter on clock signals etc. By reducing the rise times of the ECL edges it is possible to reduce the amount of voltage noise to time jitter conversion that occurs with slower edge.

The SP92701 can also be used to expand fanout and provide conversion from single ended to differential or differential to single ended ECL.

A current source located in the tail of the differential pair (Fig.2) gives the SP92701 a wide common mode range. This enables it to be used in other applications such as comparators or low cost wideband amplifiers.

Used as a line receiver in single ended non-inverting mode, the typical maximum frequency of operation is 700MHz.

**Outputs**

The outputs of the SP92701 are open emitter and hence require an external pulldown resistor for evaluation or test. It can also be useful to apply  $V_{CC} = +2V$  and  $V_{EE} = -3.2V$  for direct drive of 50Ω instruments.

**Schmitt Trigger**

Positive feedback can be applied from the output for applications that require input hysteresis.

**Board Layout**

Care should be taken with component placement. Use a solid ground plane under the device. Tracks should be short or terminated with their characteristic impedance. The supply pins should be decoupled to ground with good high frequency decoupling capacitors, located close to the device pins.

**ANALOG APPLICATION (Fig.4)**

SP92701, SL560 combination. Forming a low noise, low cost 30dB amplifier and differential line driver (100Ω twisted pair). Response is flat to 350MHz  $\pm 1dB$ .

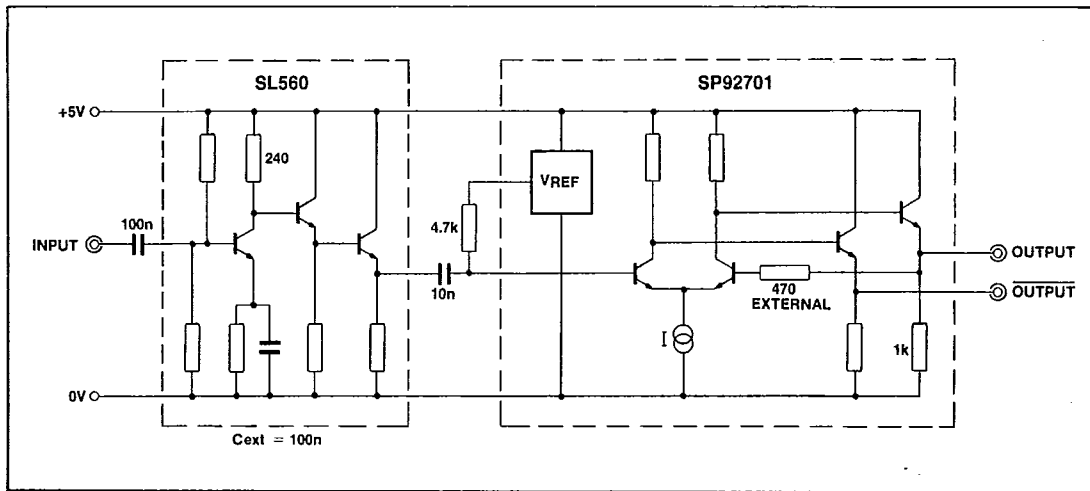

Fig.4 Low noise amp and driver