

Features

- Office machine
- AC/DC input module
- Telecommunication
- Programmable controller
- Power supply

Outline Dimensions

unit : mm

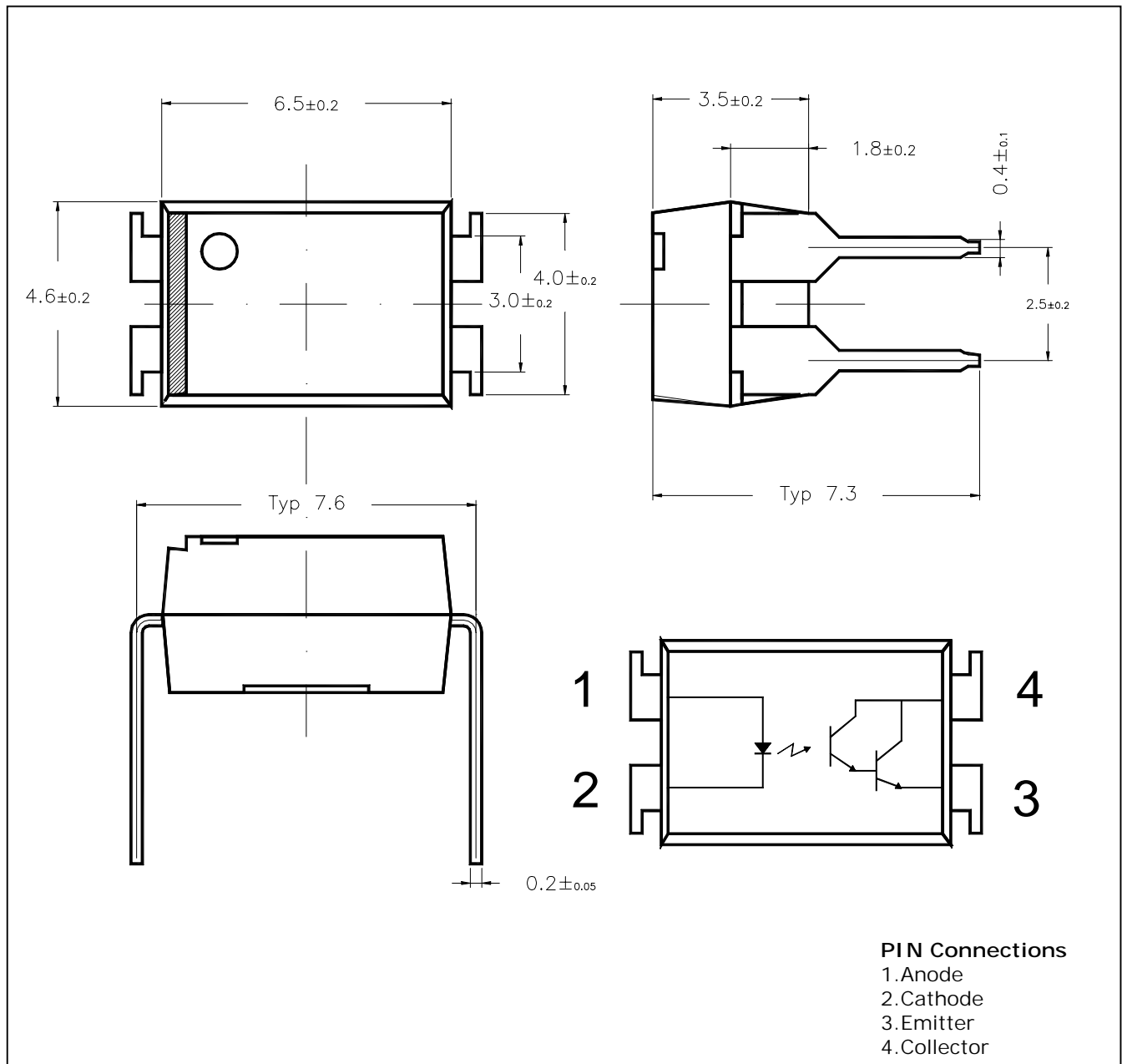

Absolute maximum ratings

(Ta=25)

Characteristic		Symbol	Ratings	Unit
IRED	Continuous Forward Current	I_F	50	mA
	Reverse Voltage	V_R	5	V
	Power Dissipation	P_D	70	mW
Detector	Collector-Emitter Voltage	V_{CEO}	35	V
	Emitter-Collector Voltage	V_{ECO}	6	V
	Collector Current	I_C	50	mA
	Power Dissipation	P_D	150	mW
Coupler	Operating Temperature	T_{opr}	-30~100	
	Storage Temperature	T_{stg}	-55~125	
	Soldering Temperature	T_{sol}	260 within 10 seconds	
	*1Isolation Voltage	V_{iso}	5,000	V_{rms}

*1.Measured at RH = 40 ~60% for 1 min

Electrical Characteristics

Parameter		Symbol	Test Condition	Min.	Typ.	Max.	Unit
IRED	Forward Current	V_F	$I_F=10mA$	-	1.15	1.3	V
	Reverse Current	I_R	$V_R=5V$	-	-	10	uA
	Capacitance	C_T	$V=0V, f=1MHz$	-	30	-	pF
Detector	Collector-Emitter Breakdown Voltage	BV_{CEO}	$I_C=0.5mA$	35	-	-	V
	Emitter-Collector Breakdown Voltage	BV_{ECO}	$I_E=10uA$	6	-	-	V
	Collector Dark Current	I_{CEO}	$I_F=0mA, V_{CE}=10V$	-	-	1	uA
	Capacitance	C_{CE}	$V_{CE}=0, f=1MHz$	-	10	-	pF
Coupler	Current Transfer Ratio	CTR	$I_F=1mA, V_{CE}=2V$	300	-	-	%
	Collector-Emitter Saturation Voltage	$V_{CE(sat)}$	$I_F=20mA, I_C=5mA$	-	0.6	0.9	V
	Input-Output Capacitance	C_{I-O}	$V=0V, f=1MHz$	-	0.8	-	pF
	Isolation Resistance	R_{iso}	DC 500V 40~60% RH	-	10^{11}		Ω
Switching Time	Rise Time	t_r	$V_{CC}=5V, R_L=100\Omega$ $I_C=2mA$	-	60	300	usec
	Fall Time	t_f		-	60	250	

Characteristic Diagrams

Fig. 1 $I_F - V_F$

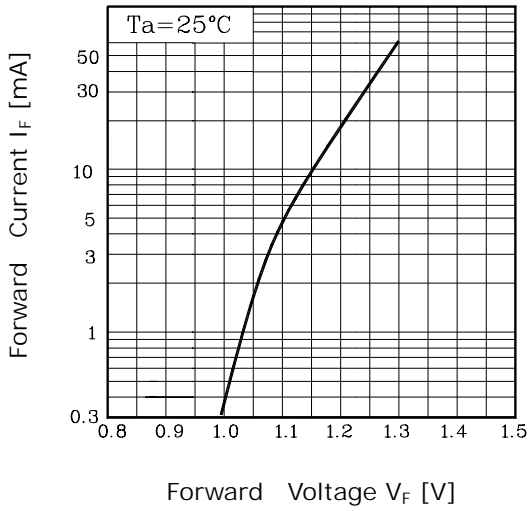

Fig. 2 CTR - I_F

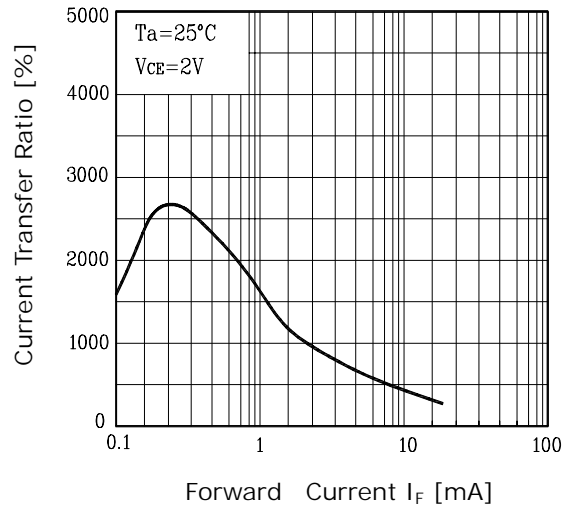

Fig. 3 $I_F - T_a$

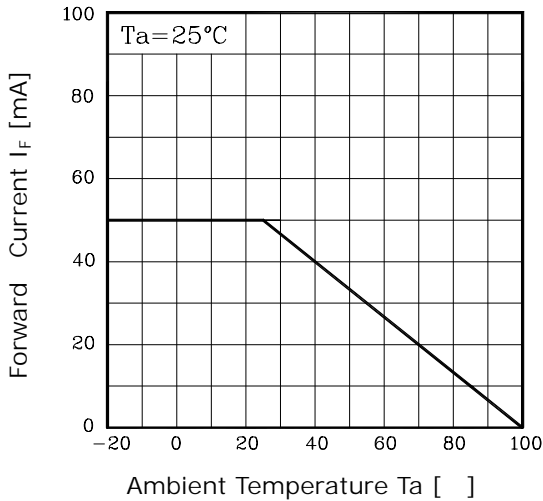

Fig. 4 $P_D - T_a$

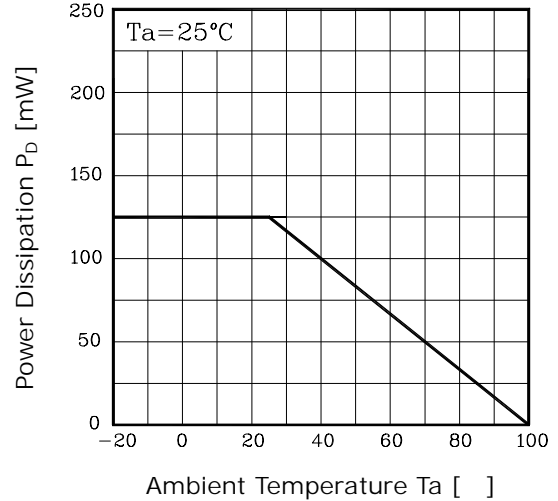

Fig. 5 $I_{CE0} - T_a$

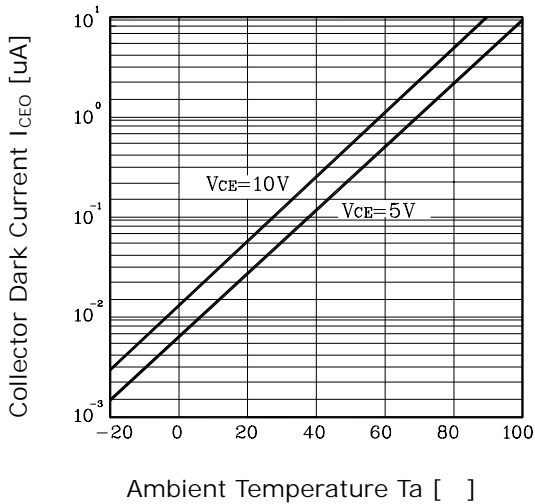

Fig. 5 $I_C - T_a$

