

SPCP168A (C3145)

USB Optical Mouse SoC

Preliminary

Dec. 13, 2010

Version 1.2

Table of Contents

	<u>PAGE</u>
1. GENERAL DESCRIPTION	3
2. FEATURES	3
3. PIN DESCRIPTION.....	4
4. PIN ASSIGNMENT.....	4
5. MANUFACTURING OPTION	5
6. ELECTRICAL CHARACTERISTICS	6
7. FUNCTION BLOCK DESCRIPTION	11
8. THE SENSOR ARRAY PIXELS MAPPING	12
9. APPLICATION CIRCUIT EXAMPLE FOR SPCP168A.....	13
10. EMI TEST SUMMARY REFERENCE	16
11 PACKAGE.....	19
12. DISCLAIMER.....	20
13. REVISION HISTORY	20

SPCP168A

1. GENERAL DESCRIPTION

The SPCP168A sensor SoC is a low cost single chip optical mouse General solution used to implement a non-mechanical tracking engine for computer mice. It is based on SPCP138A optical navigation technology which measures changes in position by optically acquiring sequential surface images and mathematically determining the direction and magnitude of movement. The General optical mouse SoC provides a complete and compact mouse solution. There are no moving parts, and precision optical alignment is not required, few outside components use and facilitate high volume assembly.

The SPCP168A is in a SFF (Small form factor) symmetrical PDIP14-pin optical package and comes with multiple CPI(counts per inch) resolution by CPI button switching and the speed of motion up to 25 inches per second. It includes 3 generally buttons (R M L); X-Y motion and a mechanical wheel encoding (1:2) for vertical scrolling and 2 extra 4th / 5th buttons optional.

USB MCU inside so that it's no more mouse controller is needed to interface through USB. The SPCP168A can receive USB command and echo status or data format, both complete USB spec V2.0 and USB HID spec V1.1 compatibility. It is also a cost effective solution to support USB Optical Mouse.

2. FEATURES

- Optical Navigation Technology
- No Mechanical Parts
- Accurate Motion Up to 25"/sec
- Enhanced navigation over a wide variety on surfaces
- 5V Power Supply
- Power Saving During No Motion
- On Chip LED Drive with Regulated Current
- IEC 60825-1 eye safety under single fault conditions
- Internal oscillator – no clock input needed .
- Compliant USB Rev2.0 Specification
- Compliant USB HID Rev1.1 Specification
- CPI resolution optional by CPI button switching (see section 5.1)
 - two segment CPI adjust :1000_(default)/1600CPI
 - support one LED for CPI inducting.
- 12bits X-Y motion for high resolution CPI
- Support generally 3 buttons and mechanical wheel encoding for vertical scrolling
- Support extend 4th / 5th buttons. (see section 5.2)
Small form factor 14Pin PDIP package available

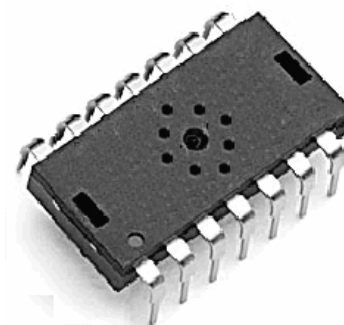

3. PIN DESCRIPTION

14 Pin SPCP168A	Pin Name	Type	Description
1	R1	I	Key Scan Input 1
2	R0	I/O	Key Scan Input 0 / CPI LED Output
3	DM/DA	I/O	USB D- or PS/2 data
4	DP/CK	I/O	USB D+ or PS/2 clock
5	VDD	P	+5 volt power supply
6	VC25	P	Internal 2.5 voltage regulator power output
7	VC33	P	USB 3.3 voltage power input
8	VSSA	P	Analog Ground
9	XY_LED	O	LED control (sink current)
10	S0	O	Key Scan Output 0
11	S1	O	Key Scan Output 1
12	ZB	I	Z axis input B
13	ZA	I	Z axis input A
14	R2	I	Key Scan Input 2

4. PIN ASSIGNMENT

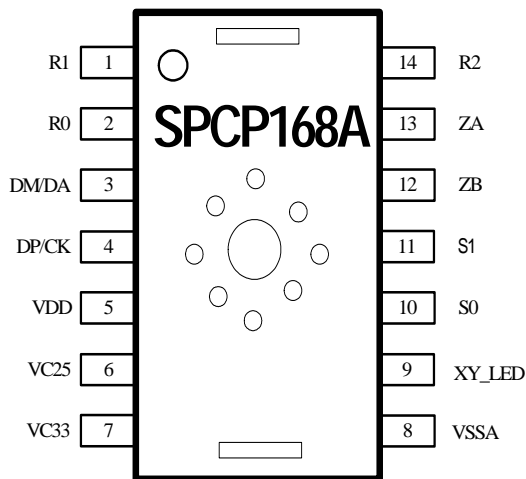

Figure 1: SPCP168A Top View Pinout

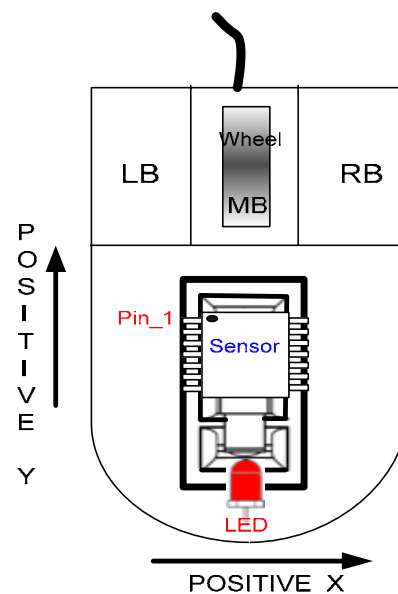

Figure 2: Top View of Mouse

5. MANUFACTURING OPTION

5.1 CPI switching with LED indicator

CPI switch resolution	CPI LED
1000CPI <small>(default)</small>	off
1600CPI	on

5.2 Buttons Key Scan Matrix Definition *(Numbers in gray are Function key number)*

<i>Row 0 (R0)</i>	<i>Row 1 (R1)</i>	<i>Row 2 (R2)</i>	
1	3	2	
LB (Left button)	RB (Right button)	MB (Middle button)	<i>Column0 (S0)</i>
4	5	6	
B4_UP (Side_up button)	B5_DN (Side_dn button)	CPI_Button	<i>Column0 (S1)</i>

6. ELECTRICAL CHARACTERISTICS

6.1 Absolute Maximum Ratings

Parameter	Symbol	Minimum	Maximum	Units	Notes
Supply Voltage	VDD	-0.5	5.5	V	
Operating Temperature	T _A	-15	55		
Storage temperature	T _S	-40	85		
Lead Solder temp	-	-	260		
ESD	-	-	2	KV	All pins, human body model
Input Voltage	V _{IN}	-0.5	5.5	V	

6.2 Recommend Operating Conditions

Parameter	Symbol	Minimum	Typical	Maximum	Units	Notes
Supply Voltage	VDD	4.25	5.0	5.25	V	
Operating Temperature	T _A	0	-	40		
Internal OSC Frequency	f _{CLK}	-	6.0	-	MHz	VDD=5V
Power Consumption	IDD	-	-	TBD	mA	VDD=5.5V
USB Suspend Current	ISUSP	-	-	400	uA	VDD=5.25V
Low Voltage Detect	VLVDZ	-	3.6	-	V	
Low Voltage Reset	VLVRZ	-	3.0	-	V	

6.3 Optical Navigation Operating Conditions

Parameter	Symbol	Minimum	Typical	Maximum	Units	Notes
Distance From lens reference plane to surface	Z	2.3	2.4	2.5	mm	
Speed	S	-	-	25	In/sec	
Acceleration	A	-	0.15	8	G	
Light level onto IC	IRR _{INC}	-	TBD	-	MW/m ²	=639 nm
XY_LED Current	I _{LED}	-	30	-	mA	@Voltage of XY_LED = 0.8v

6.4 DC Electrical Specifications (VDD = 5.0V, Temperature = 25°C)

Mnemonic	Description	Item	Min.	Typ.	Max.	Unit	Condition
VC33	3.3 V regulator output reference	V _{O33}	3.0	3.3	3.6	V	VDD=5V
VC25	2.5 V regulator output reference	V _{O25}	-	2.5		V	VDD=5V
DP/CK	Input Voltage High	V _{IH}	2.0	-		V	
	Input Voltage Low	V _{IL}	-	-	0.8	V	
	Output Voltage High	V _{OH}	2.8	-	3.6	V	
	Output Voltage Low	V _{OL}	0	-	0.3	V	
DM/DA	Input Voltage High	V _{IH}	2.0	-		V	
	Input Voltage Low	V _{IL}	-	-	0.8	V	
	Output Voltage High	V _{OH}	2.8	-	3.6	V	
	Output Voltage Low	V _{OL}	0	-	0.3	V	
	USB mode Pull-up	R _{PU}	1.20	1.50	1.80	KΩ	
R0 ~ R2 S0 ~ S1 ZA/ZB	Input Voltage High	V _{IH}	2.0	-		V	V _{OH} = 2.2V for ZA/ZB only Source current = 8 mA Sink current = 8 mA V _{IN} = VDD V _{IN} = VSS
	Input Voltage Low	V _{IL}	-	-	0.8	V	
	Output Voltage High	V _{OH}	2.2/2.4	-		V	
	Output Voltage Low	V _{OL}	-	-	0.5	V	
	Pull down Resistor	R _{PD}	35	50	65	KΩ	
	Pull up Resistor	R _{PU}	10.5	15	19.5	KΩ	
All	I/O Port Hi-Z Leakage	R _{PUP}	75	150	225	KΩ	
		I _Z	-	-	10	μA	R _P inactive

* The frequency defined in this item is based on the CPU frequency. It is one-half of the oscillation frequency.

6.5 AC Electrical Specifications (VDD = 5.0V, Temperature = 25°C)

Characteristics	Item	Min.	Typ.	Max.	Unit	Condition
Internal Ring oscillator frequency	F _{ROSC}	1.75	3.5	5.25	KHz	
Sleep mode delay from no motion to low power	T _{SLEEP}	-	1000	-	ms	
Wakeup delay from sleep mode due to motion	T _{WUPP}	-	50	100	ms	
Power up delay	T _{PUP}	-	-	50	ms	From VDD reach 4.25V until spec's met
Flashing frequency of LED	F _{LED}	-	125	-	Hz	
Debounce delay on button input	T _{DBB}	5	9	15	ms	
Z Wheel sampling period	T _{ZW}	120	200	300	us	

6.6 USB Electrical Specifications (VDD = 5.0V, Temperature = 25°C)

Characteristics	Item	Min.	Max.	Unit	Condition
Output Signal Crossover Voltage	V _{CRS}	1.3	2.0	V	C _L = 200pF ~ 600pF
Input Signal Crossover Voltage	V _{ICRS}	1.2	2.1	V	C _L = 200pF ~ 600pF
Differential Input Sensitivity	V _{DI}	0.2	-	V	[(D+) – (D-)] See Figure 5
Differential Input Common Mode Range	V _{CM}	0.8	2.5	V	Include V _{DI} , See Figure 5
Single Ended Receiver Threshold	V _{SE}	0.8	2.0	V	
Transceiver Input Capacitance	C _{IN}	-	20	pF	D+ to VBUS, D- to VBUS
Output High	C _{OH}	2.8	3.6	V	with 15k to GND and 3.3V internal regulator through 1.5K to D-, See Figure 4
Output Low	C _{OH}	0	0.3	V	with 15k to GND and 3.3V internal regulator through 1.5K to D-, See Figure 5
Single Ended Output	V _{SED}	-	0.8	V	
Input High (Driven)	V _{IH}	-	2.0	V	
Input High (Floating)	V _{IHZ}	2.7	3.6	V	
Input Low	V _{IL}	-	0.5	V	

6.7 USB Timing Specifications (VDD = 5.0V, Temperature = 25°C)

Characteristics	Item	Min.	Max.	Unit	Condition
USB Low-Speed Rise Time / Fall Time	T _{LR} /T _{LF}	75	300	ns	C _L = 200pF ~ 600pF, See Figure 4
Rise and Fall time matching	V _{LRFM}	80	125	%	T _R /T _F ; C _L = 200pF; Excluding the first transition from the idle time
USB reset time	T _{RESET}	8.6	10	us	
Data Rate	t _{LDRATE}	1.4775	1.5225	Mb/s	Average bit rate, 1.5Mb/s +/-1/5%
Receiver Jitter Tolerance	t _{DJR1}	-75	75	ns	To next transition, see Figure 7
Receiver Jitter Tolerance	t _{DJR2}	-45	45	ns	For paired transition, see Figure 7
Differential to EOP Transition Skew	t _{LDEOP}	-40	100	ns	See Figure 7
EOP Width at Receiver	t _{LEOPR}	670	-	ns	Accepts EOP, see Figure 7
Source EOP Width	t _{LEOPT}	1.25	1.5	us	
Width of SE0 interval during differential Transition	t _{LST}	-	210	ns	
Differential Output Jitter	t _{UDJ1}	-95	95	ns	To next transition, see Figure 8
Differential Output Jitter	t _{UDJ2}	-150	150	ns	For paired transition, see Figure 8

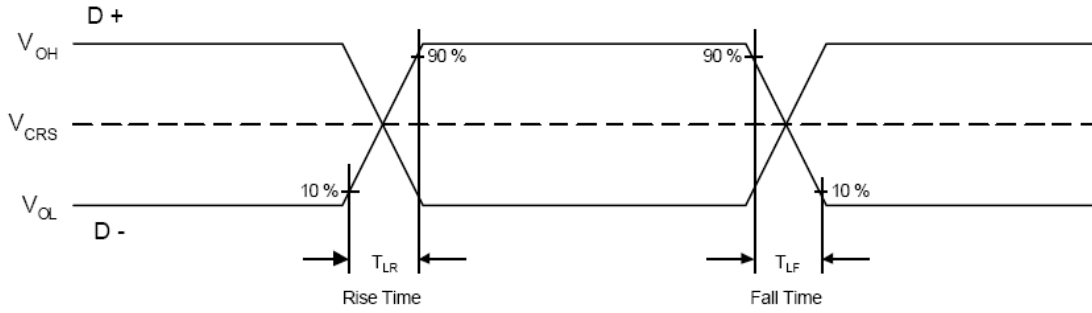

Figure 3: Data Signal Rise and Fall Times

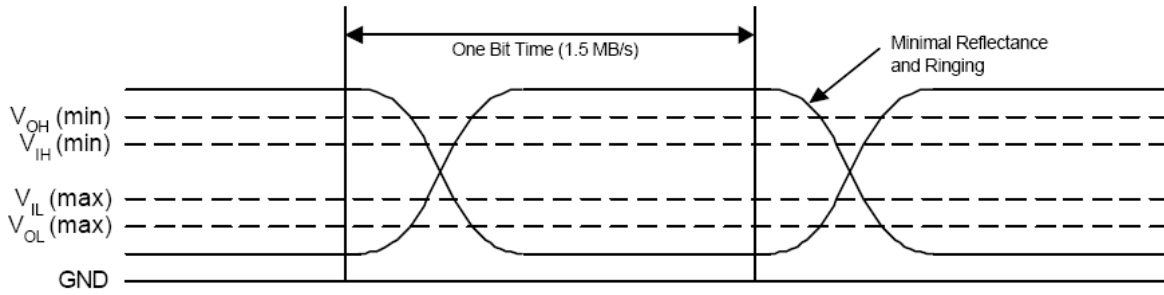

Figure 4: Data Signal Voltage Levels

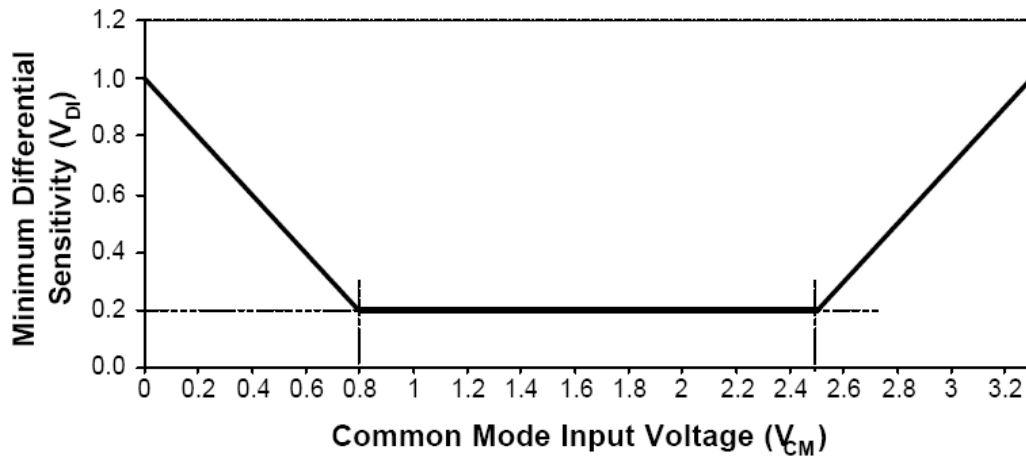

Figure 5: Differential Receiver Input Sensitivity vs. Common Mode Input Range

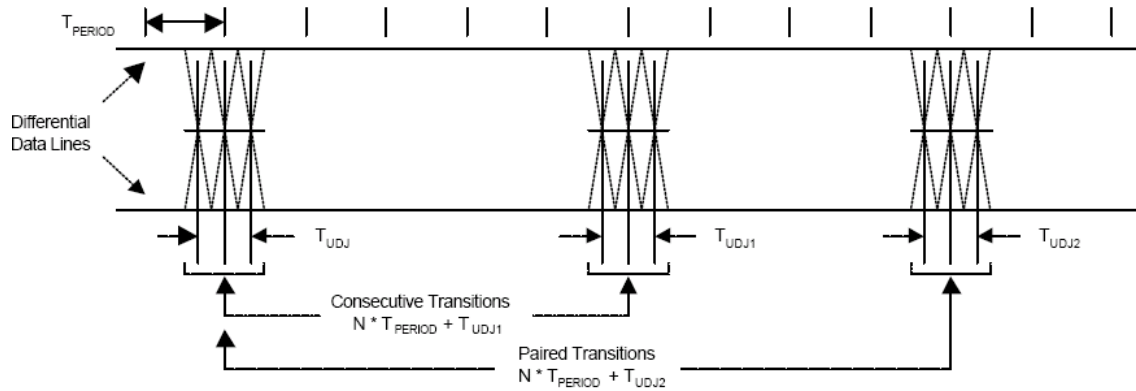

Figure 6: Receiver Jitter Tolerance

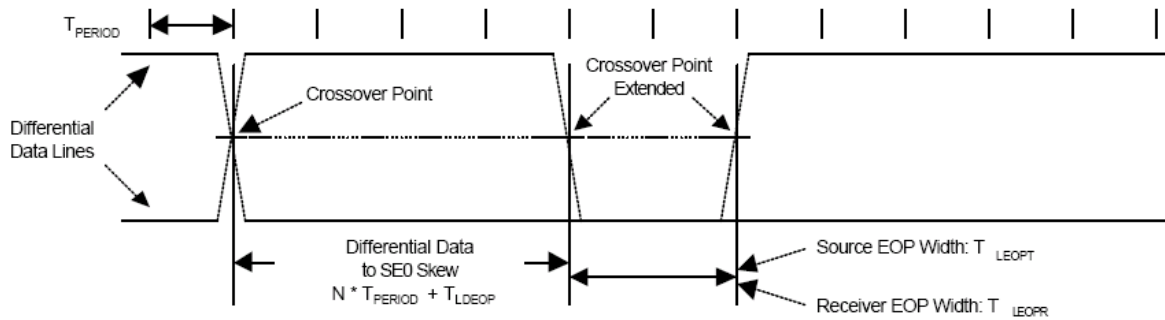

Figure 7: Differential to EOP Transition Skew and EOP Width

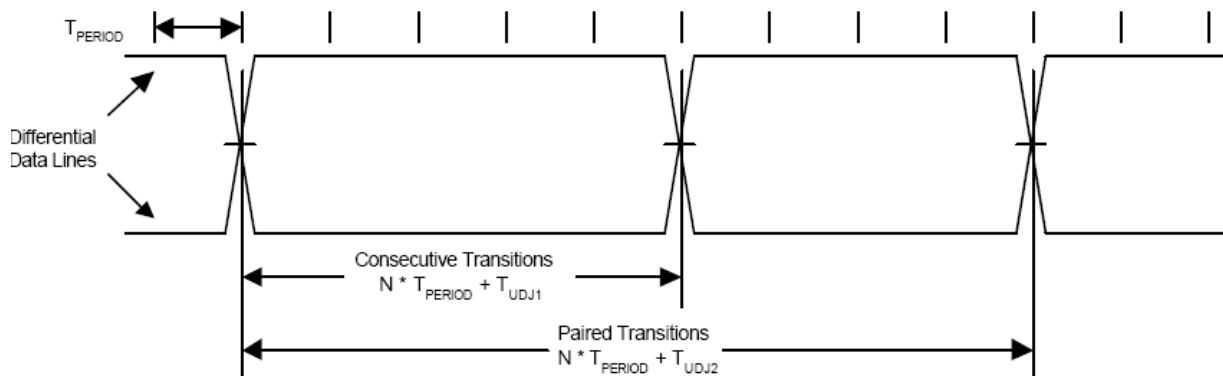

Figure 8: Differential Output Jitter

7. FUNCTION BLOCK DESCRIPTION

Please contact SunplusIT sales representatives for more information.

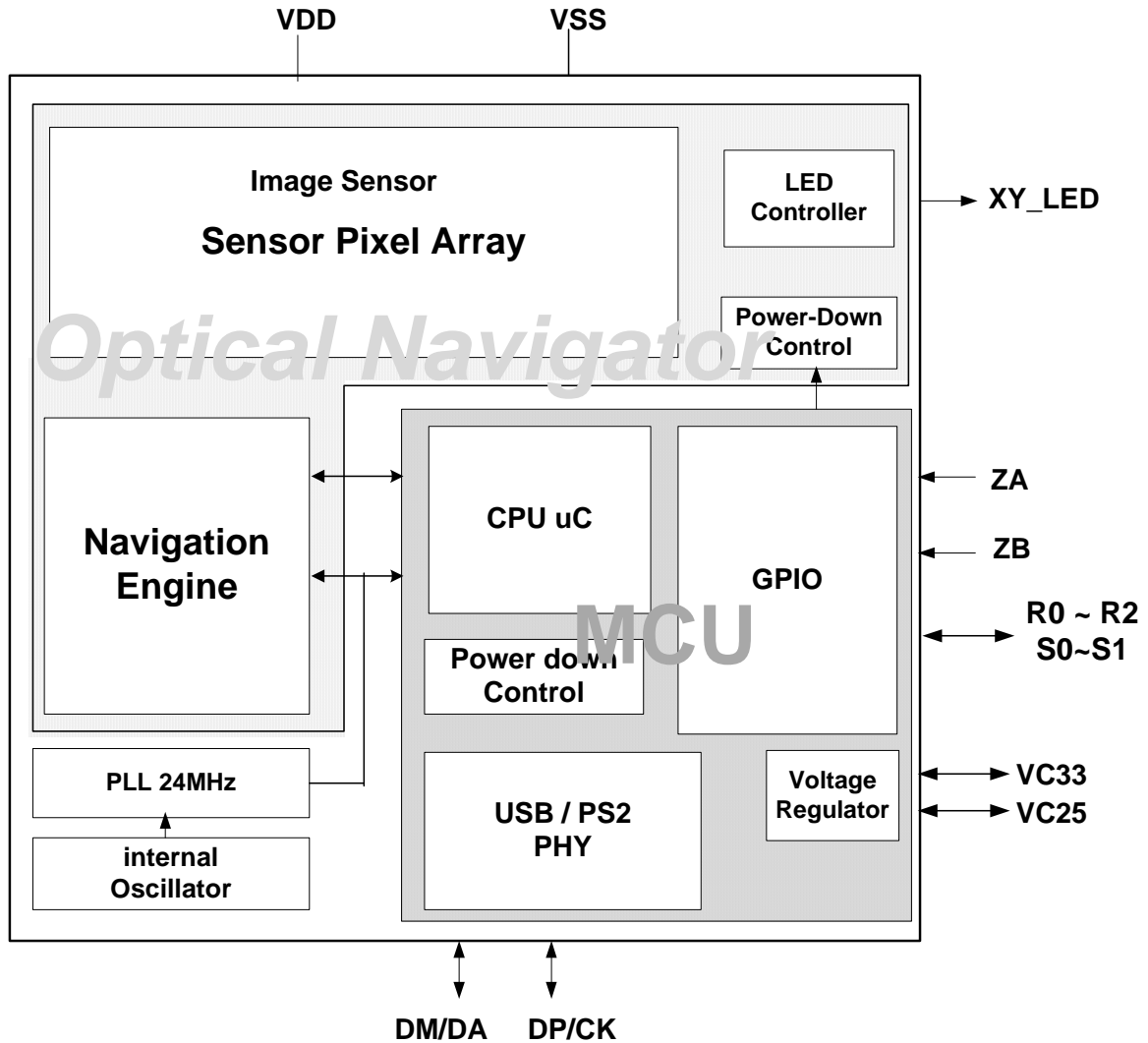

Figure 9: Block Diagram

8. THE SENSOR ARRAY PIXELS MAPPING

PIXEL ADDRESS MAP

(Looking through the lens)

LAST PIXEL

FF	FE	FD	FC	FB	FA	F9	F8	F7	F6	F5	F4	F3	F2	F1	F0
EF	EE	ED	EC	EB	EA	E9	E8	E7	E6	E5	E4	E3	E2	E1	E0
DF	DE	DD	DC	DB	DA	D9	D8	D7	D6	D5	D4	D3	D2	D1	D0
CF	CE	CD	CC	CB	CA	C9	C8	C7	C6	C5	C4	C3	C2	C1	C0
BF	BE	BD	BC	BB	BA	B9	B8	B7	B6	B5	B4	B3	B2	B1	B0
AF	AE	AD	AC	AB	AA	A9	A8	A7	A6	A5	A4	A3	A2	A1	A0
9F	9E	9D	9C	9B	9A	99	98	97	96	95	94	93	92	91	90
8F	8E	8D	8C	8B	8A	89	88	87	86	85	84	83	82	81	80
7F	7E	7D	7C	7B	7A	79	78	77	76	75	74	73	72	71	70
6F	6E	6D	6C	6B	6A	69	68	67	66	65	64	63	62	61	60
5F	5E	5D	5C	5B	5A	59	58	57	56	55	54	53	52	51	50
4F	4E	4D	4C	4B	4A	49	48	47	46	45	44	43	42	41	40
3F	3E	3D	3C	3B	3A	39	38	37	36	35	34	33	32	31	30
2F	2E	2D	2C	2B	2A	29	28	27	26	25	24	23	22	21	20
1F	1E	1D	1C	1B	1A	19	18	17	16	15	14	13	12	11	10
0F	0E	0D	0C	0B	0A	09	08	07	06	05	04	03	02	01	00

FIRST PIXEL

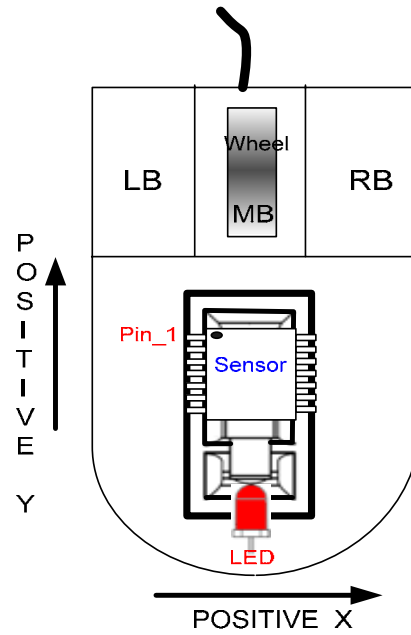

Directions are for a complete mouse with the Lens.

Figure 10: Sensor Pixels Array and XY Direction Mapping

9. APPLICATION CIRCUIT EXAMPLE FOR SPCP168A

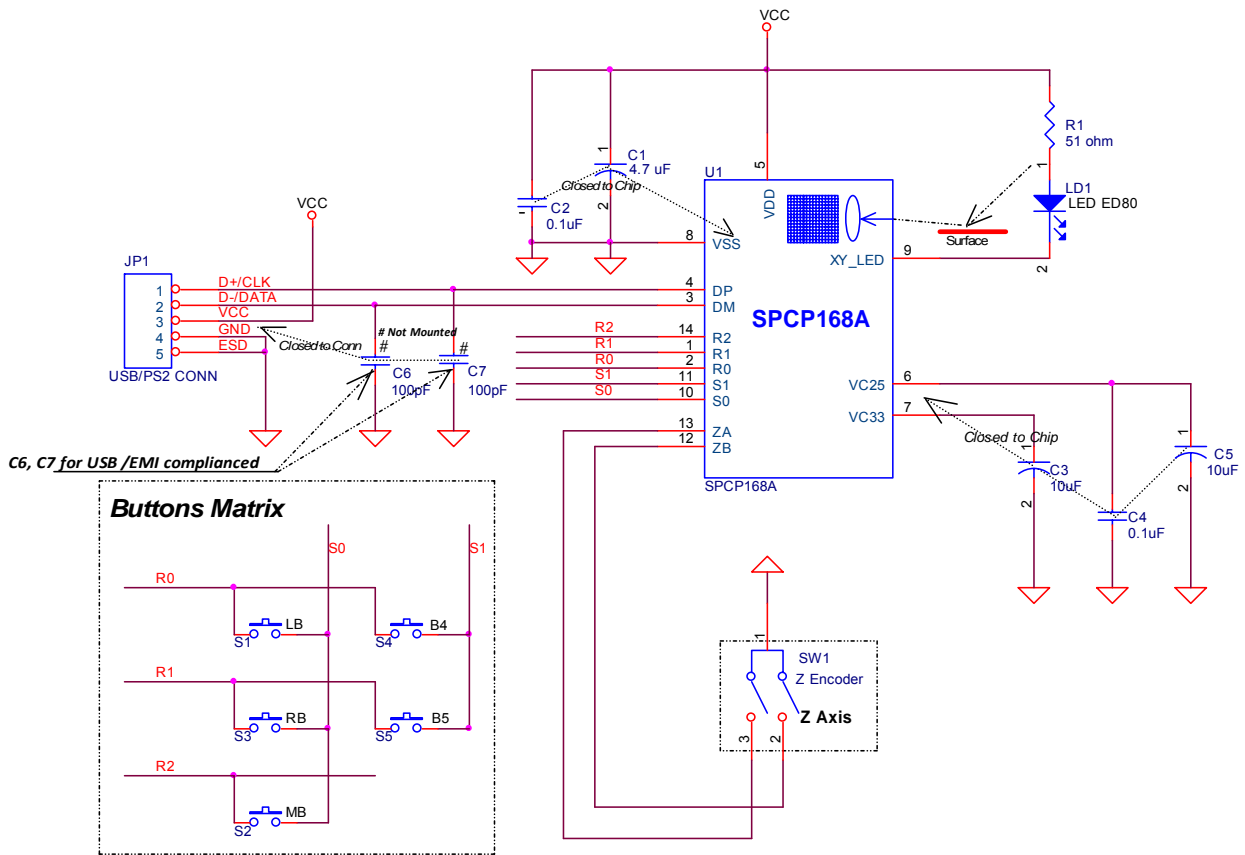

Figure 11: SPCP168A – 5 Buttons Wheel Mouse SoC application circuitry (Generic)

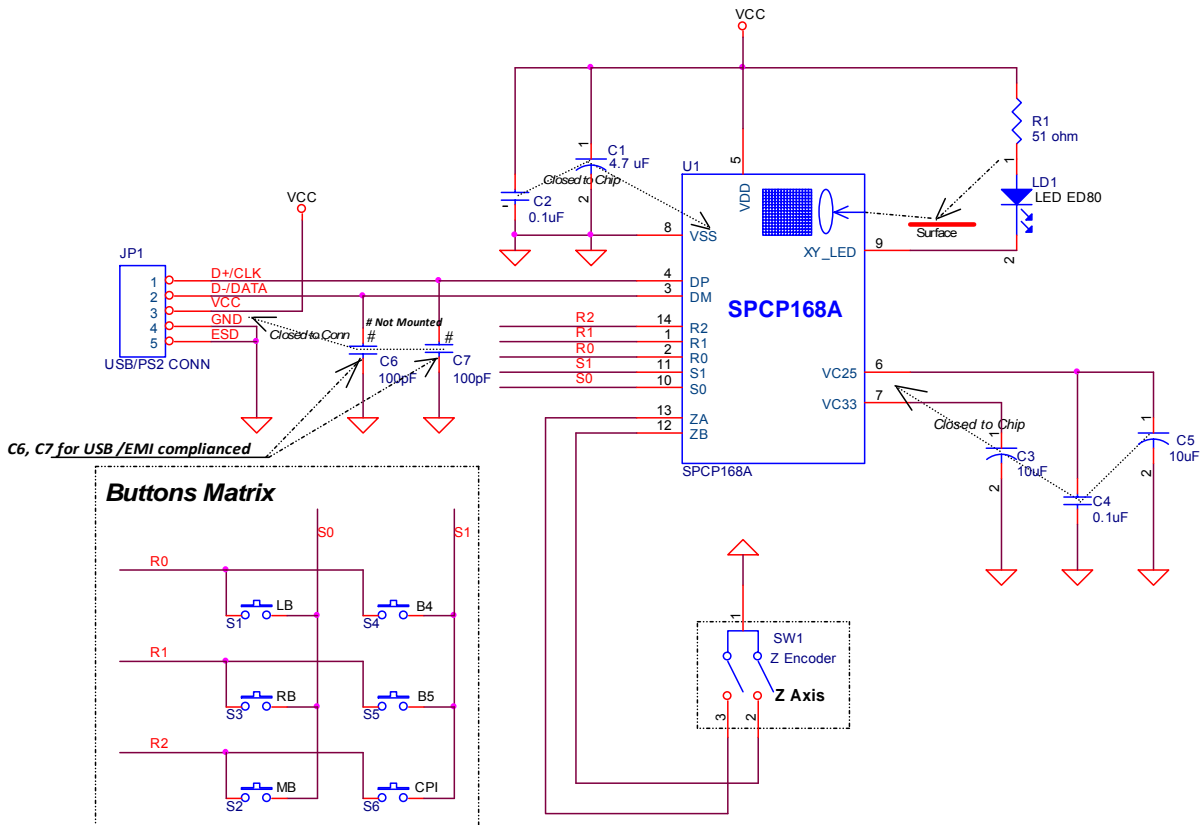

Figure 12: SPCP168A – 5 Buttons Wheel Mouse SoC with CPI switch application circuitry (none CPI LED)

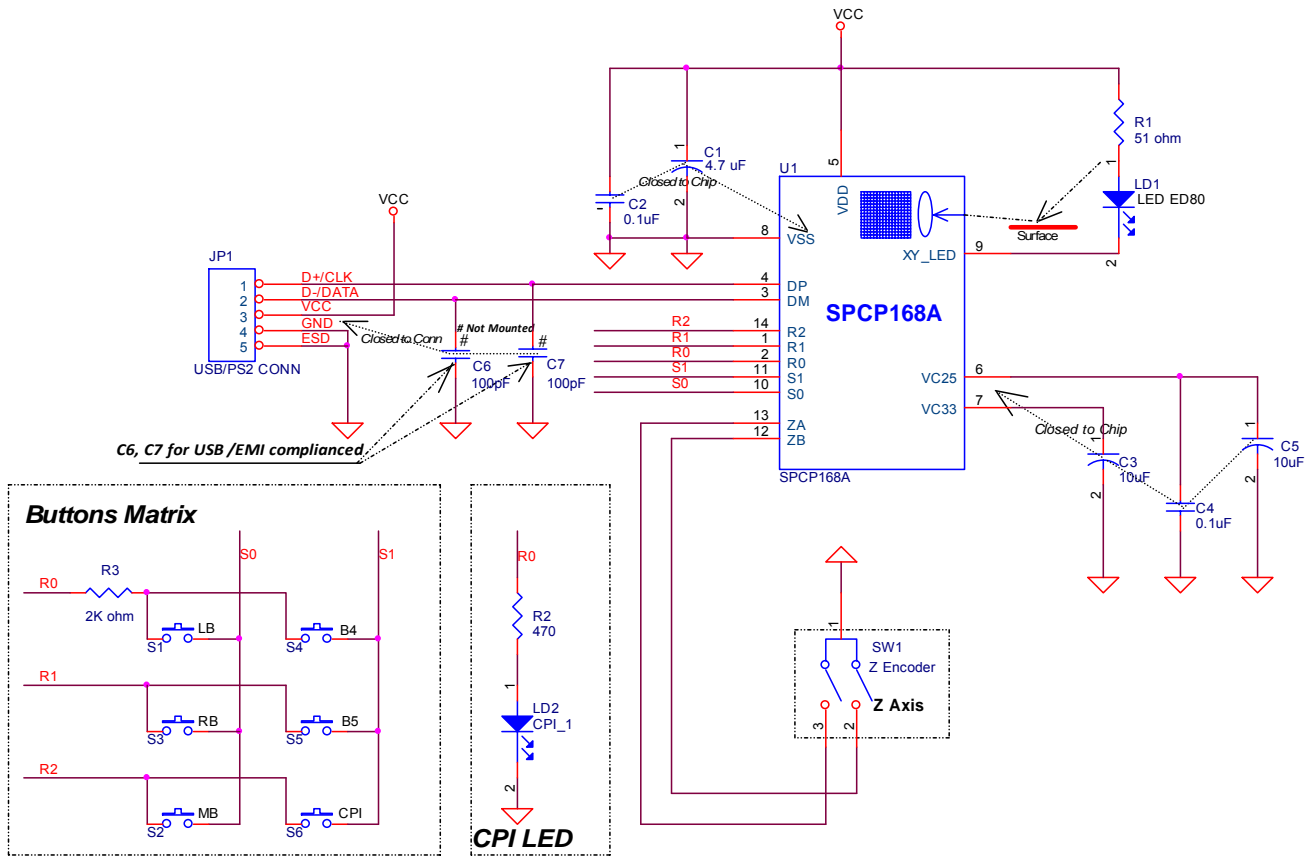

Figure 13: SPCP168A - 5Buttons Wheel Mouse SoC with CPI and LED application circuitry

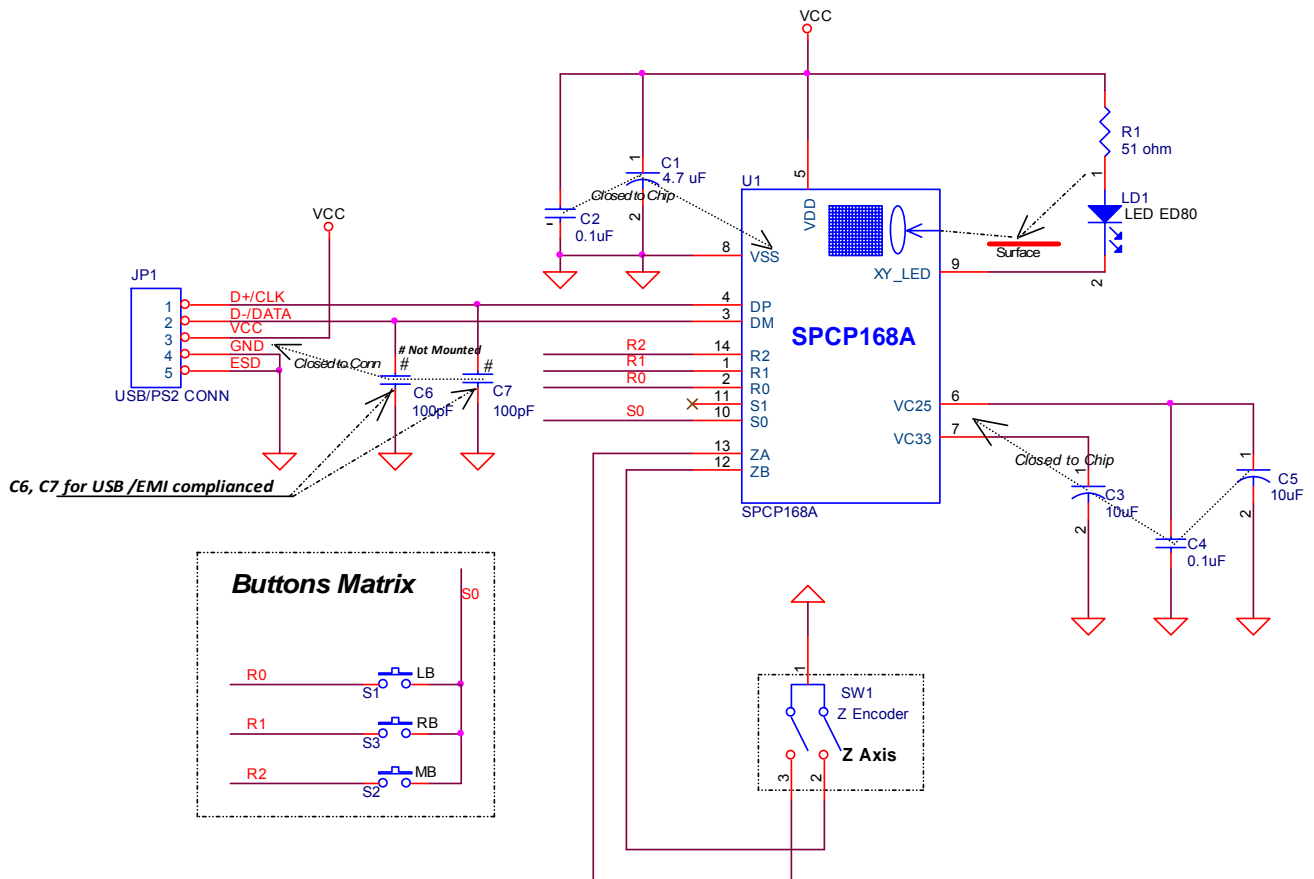

Figure 14: SPCP168A - 3 Buttons Wheel Mouse SoC application circuitry (Generic)

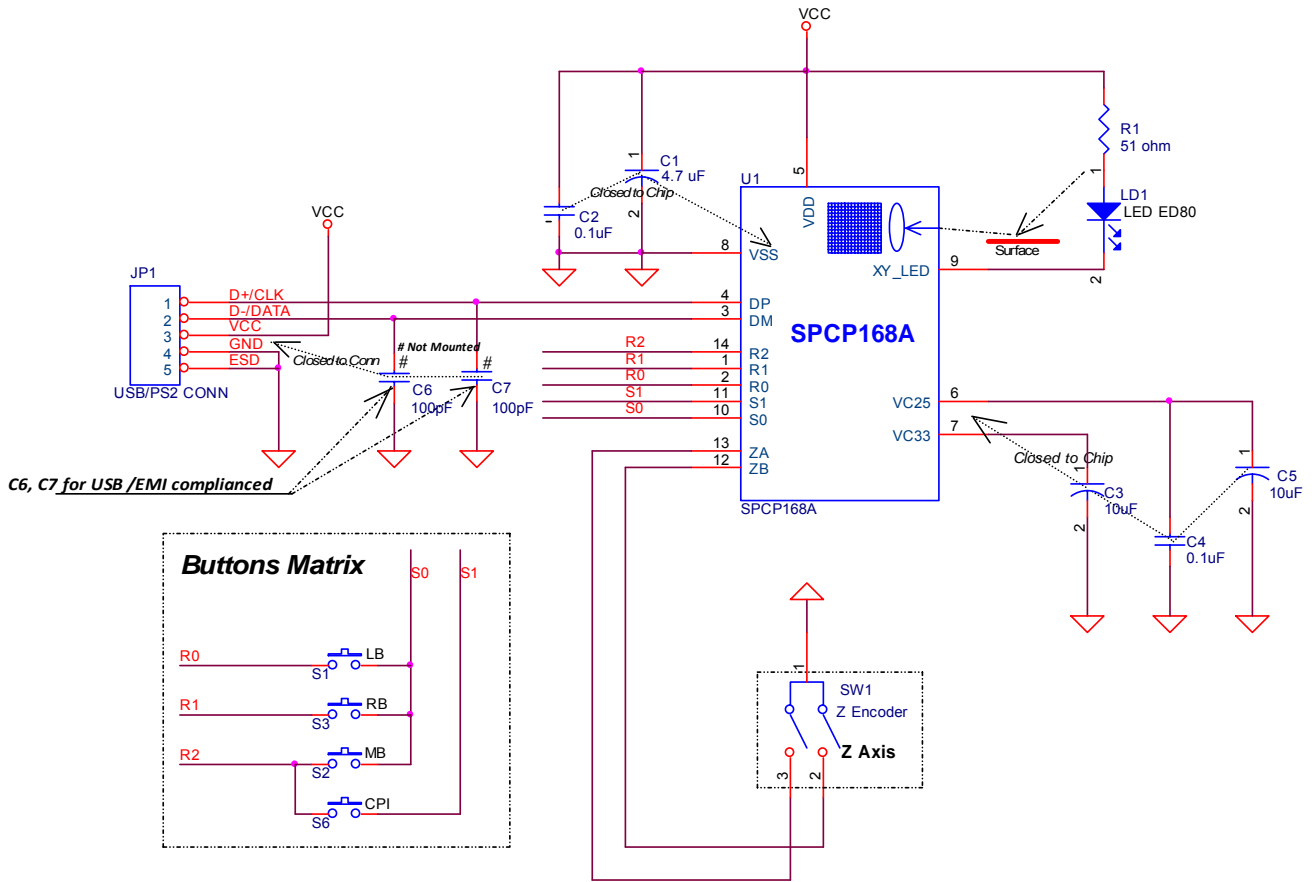

Figure 15: SPCP168A – 3 Buttons Wheel Mouse SoC with CPI switch application circuitry (none CPI LED)

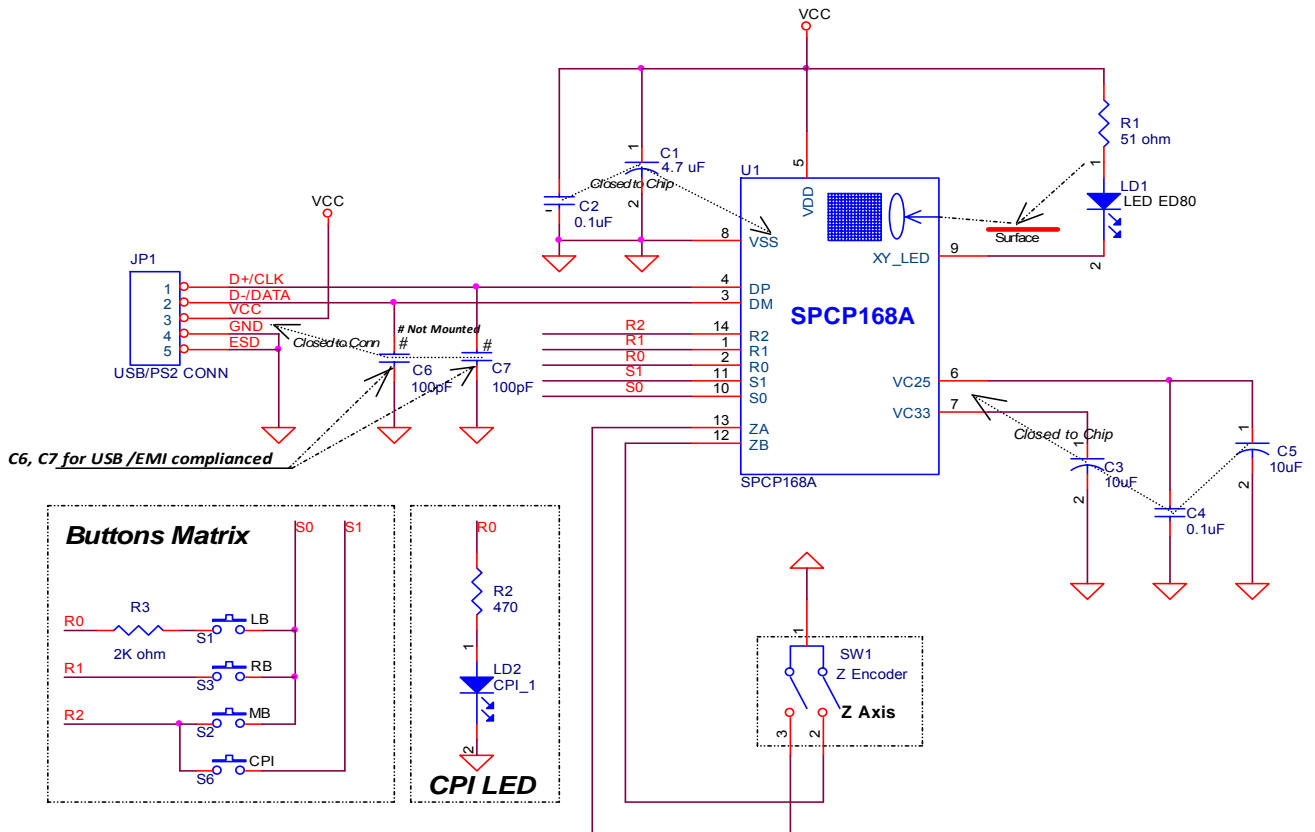
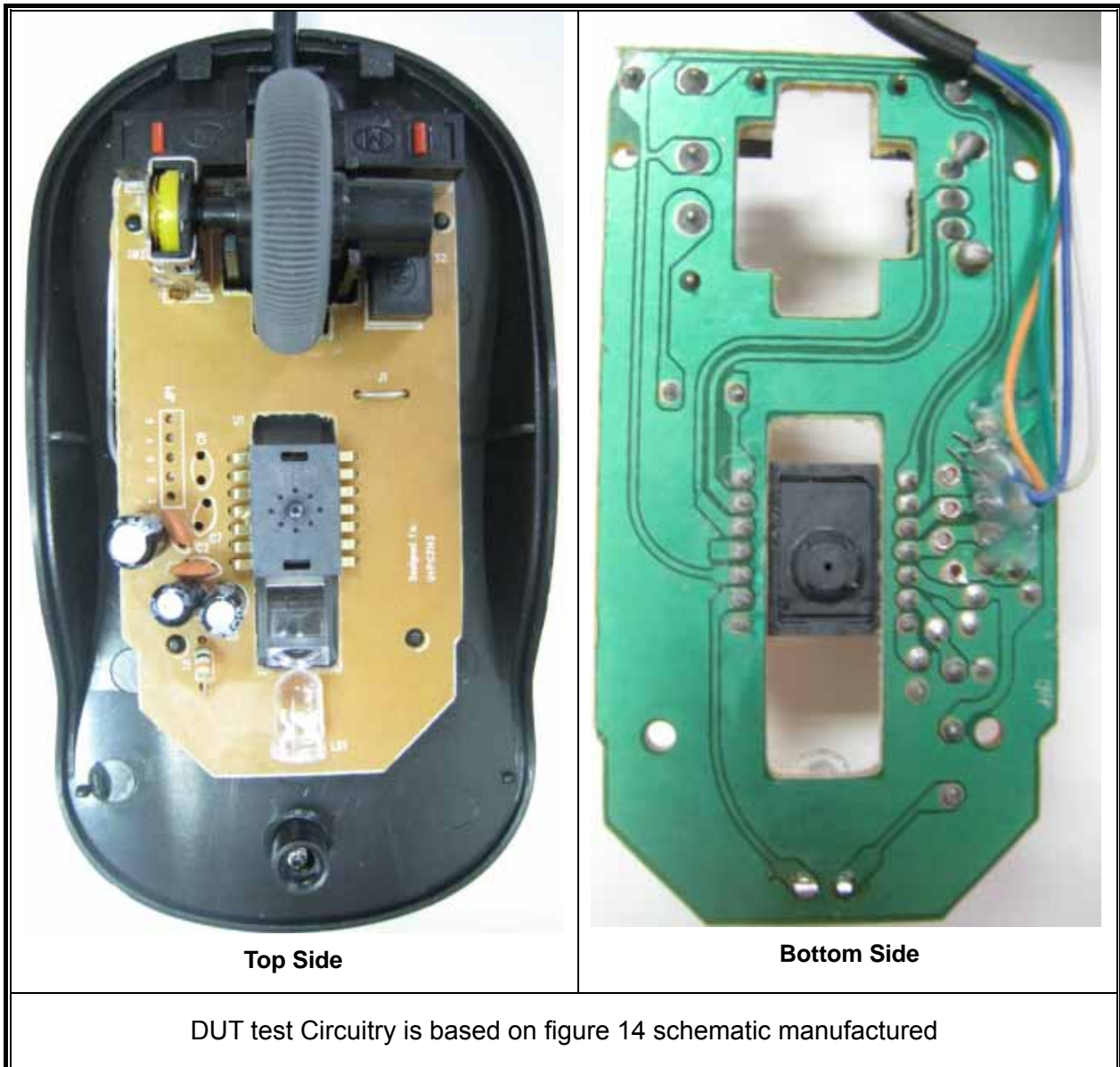

Figure 16: SPCP168A – 3 Buttons Wheel Mouse SoC with CPI and LED application circuitry

10. EMI Test Summary Reference

10.1 DUT sample photo





Neutron Engineering Inc.

Shenzhen new kam hon electronic technology Co., LTD
 TEL:+86-0755-82565136
 FAX:+86-0755-82565136
 Phone:13670234576
 Emila:1315033070@qq.com

Radiated Emission Measurement

File :M2-1

Data :#28

Date: 2010-12-6

Time: 13:10:10

80.0 dBuV/m

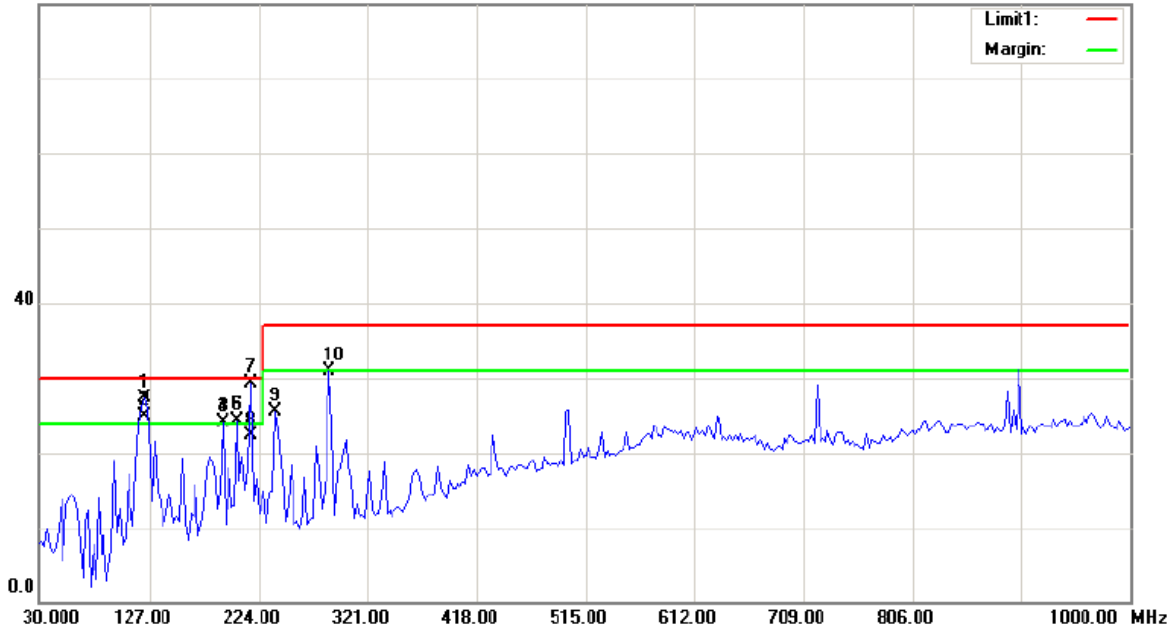

Site DG-CB03

Polarization: **Horizontal**

Temperature: 23

Limit: CISPR22 ClassB 10M Radiation

Power: AC 230V/50Hz

Humidity: 58 %

EUT: MOUSE

Distance: 10m

M/N: M2-3

Mode: USB

No.	Mk.	Freq. MHz	Reading Level dBuV	Correct Factor dB	Measure- ment dBuV/m	Limit dBuV/m	Over dB	Detector	Comment
1	I	122.1500	51.05	-23.65	27.40	30.00	-2.60	peak	
2	I	122.1500	48.60	-23.65	24.95	30.00	-5.05	QP	
3	I	192.4750	47.64	-23.51	24.13	30.00	-5.87	peak	
4	I	192.4750	47.64	-23.51	24.13	30.00	-5.87	peak	
5	I	204.6000	47.55	-23.24	24.31	30.00	-5.69	peak	
6	I	204.6000	47.55	-23.24	24.31	30.00	-5.69	peak	
7	*	216.7250	52.34	-23.02	29.32	30.00	-0.68	peak	
8		216.7250	45.30	-23.02	22.28	30.00	-7.72	QP	
9		238.5500	47.18	-21.76	25.42	37.00	-11.58	peak	
10		287.0500	51.15	-20.24	30.91	37.00	-6.09	peak	

*:Maximum data x:Over limit I:over margin

(Reference Only)

Note: under test criteria -3dB; Passed CE / FCC test requirement

10.3 SPCP168A EMI Test Summary (Vertical)

Shenzhen new kam hon electronic technology Co., LTD
 TEL:+86-0755-82565136
 FAX:+86-0755-82565136
 Phone:13670234576
 Emila:1315033070@qq.com



Neutron
Engineering Inc.

Radiated Emission Measurement

File :M2-1 Data :#29 Date: 2010-12-6 Time: 13:16:52

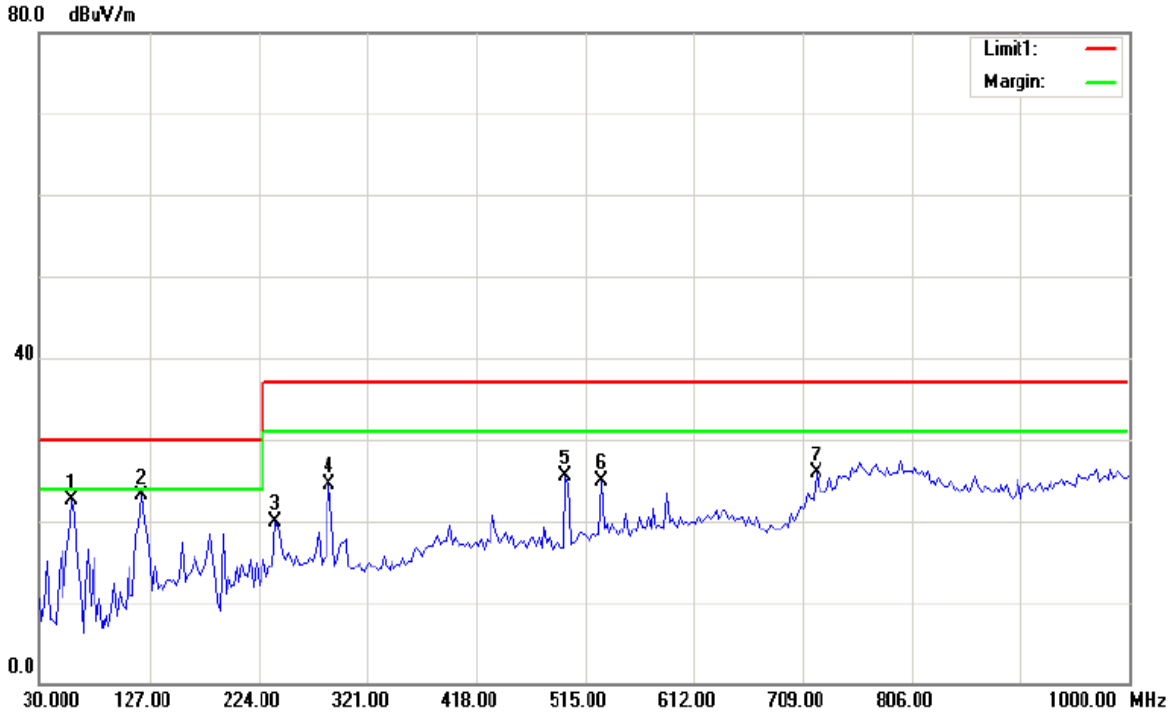

Site DG-CB03	Polarization: Vertical	Temperature: 23
Limit: CISPR22 ClassB 10M Radiation	Power: AC 230V/50Hz	Humidity: 58 %
EUT: MOUSE	Distance: 10m	
M/N: M2-3		
Mode: USB		

No.	Mk.	Freq. MHz	Reading Level dBuV	Correct Factor dB	Measure- ment dBuV/m	Limit dBuV/m	Over dB	Detector	Comment
1		59.1000	45.92	-23.50	22.42	30.00	-7.58	peak	
2	*	119.7250	43.97	-20.78	23.19	30.00	-6.81	peak	
3		238.5500	37.37	-17.43	19.94	37.00	-17.06	peak	
4		287.0500	41.48	-17.06	24.42	37.00	-12.58	peak	
5		498.0250	40.73	-15.25	25.48	37.00	-11.52	peak	
6		529.5500	39.88	-15.04	24.84	37.00	-12.16	peak	
7		721.1250	34.89	-8.98	25.91	37.00	-11.09	peak	

*:Maximum data x:Over limit !:over margin (Reference Only)

Note: under test criteria -3dB; Passed CE / FCC test requirement

11 PACKAGE

11.1 SPCP168A 14Pin Package Dimension

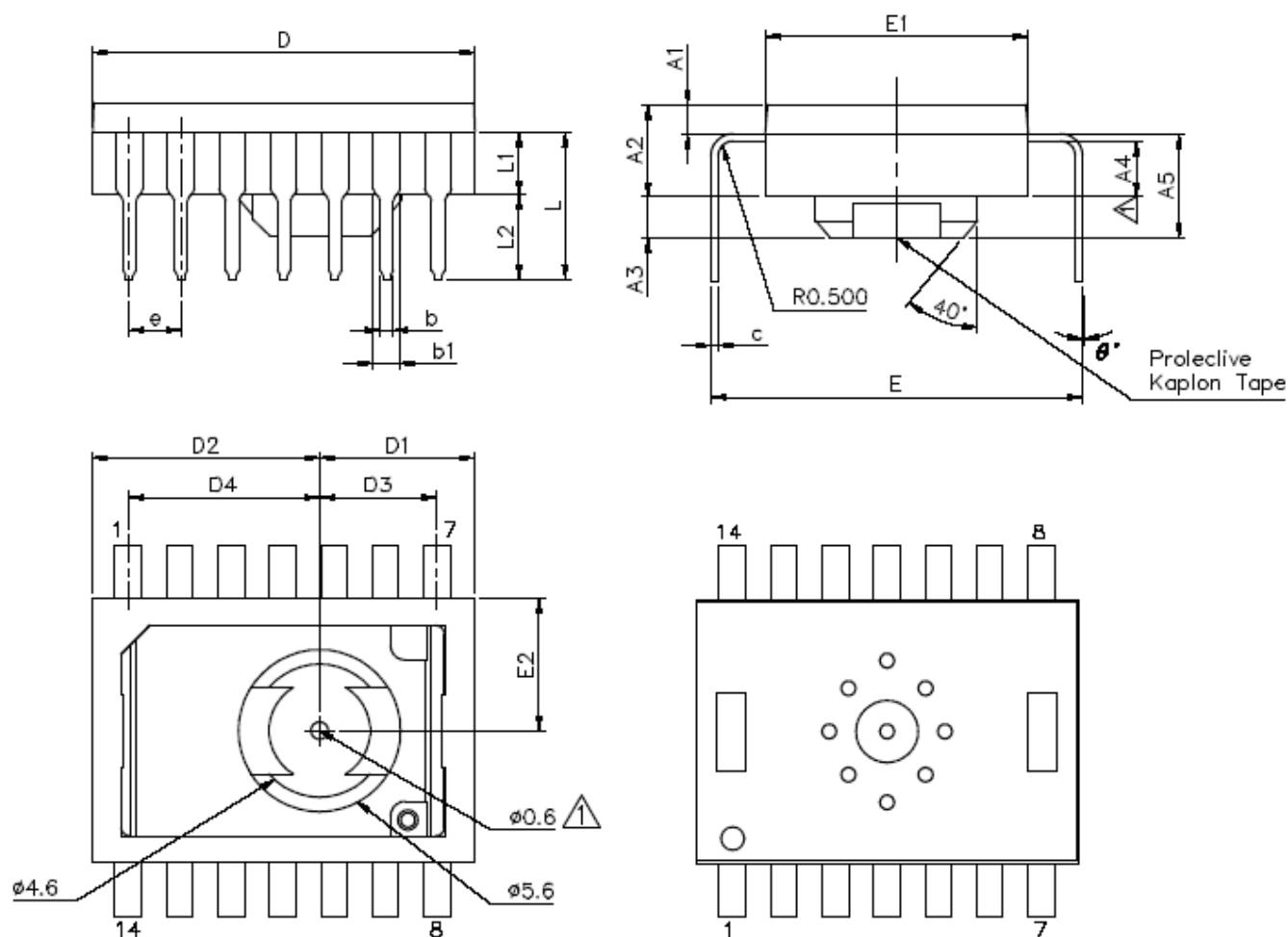

SYMBOLS	MIN.	NOM.	MAX.
A1	0.90	1.00	1.10
A2	2.98	3.08	3.18
A3	1.32	1.42	1.52
△ A4	1.726	1.826	1.926
A5	3.60 REF.		
b	0.456 TYP.		
b1	0.922 TYP.		
c	0.254 TYP.		
e	1.778 TYP.		
D	13.11	13.21	13.31

SYMBOLS	MIN.	NOM.	MAX.
D1	5.24	5.34	5.44
D2	7.78	7.88	7.98
D3	3.96	4.06	4.16
D4	6.50	6.60	6.70
E	12.65	12.85	13.05
E1	9.00	9.10	9.20
E2	4.45	4.55	4.65
L	4.98	5.08	5.18
L1	2.08	2.18	2.28
L2	2.80	2.90	3.00
θ	-2°	-	+2°

NOTES :

1. DIMENSIONS IN MM.
2. COPLANARITY OF LEADS : 0.1 MM.
3. LEAD PITCH TOLERANCE : ±0.15 MM.
4. CUMULATIVE PITCH TOLERANCE : ±0.15 MM.

11.2 Ordering Information

Product Number	Package Type
SPCP168A –HR033	Package form - PDIP14

Notes:

- 1.) If needs code programming service, please contact with SunplusIT sales representatives for more information
- 2.) Above ordering information are for the green packages (default) only

12. DISCLAIMER

The information appearing in this publication is believed to be accurate.

Integrated circuits sold by Sunplus Innovation Technology are covered by the warranty and patent indemnification provisions stipulated in the terms of sale only. SUNPLUSIT makes no warranty, expressed, statutory implied or by description regarding the information in this publication or regarding the freedom of the described chip(s) from patent infringement. FURTHERMORE, SUNPLUSIT MAKES NO WARRANTY OF MERCHANTABILITY OR FITNESS FOR ANY PURPOSE. SUNPLUSIT reserves the right to halt production or alter the specifications and prices at any time without notice. Accordingly, the reader is cautioned to verify that the data sheets and other information in this publication are current before placing orders. Products described herein are intended for use in normal commercial applications. Applications involving unusual environmental or reliability requirements, e.g. military equipment or medical life support equipment, are specifically not recommended without additional processing by SUNPLUSIT for such applications. Please note that application circuits illustrated in this document are for reference purposes only.

13. REVISION HISTORY

Date	Revision #	Description	Page
DEC. 13, 2010	1.2	Revised application circuitry Added EMI test summary	13 ~15 16 ~18
JUL. 31, 2010	1.1	Revised application circuitry	13 ~15
MAY. 31, 2010	1.0	Original	17