

SPE20S60F-A

TRANSFER-MOLD TYPE
FULL PACK TYPE

SPE20S60F-A

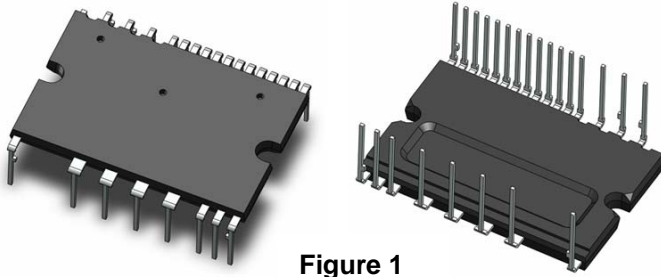

Figure 1

INTEGRATED POWER FUNCTIONS

600V/20A low-loss 6th generation IGBT inverter bridge for three phase DC-to-AC power conversion.

Open emitter type.

INTEGRATED DRIVE, PROTECTION AND SYSTEM CONTROL FUNCTIONS

- For upper-leg IGBTs : Advanced input filter, Shoot through prevention, Drive circuit, High voltage high-speed level shifting, Control supply under-voltage (UV) protection, Short circuit protection (SC), Integrate bootstrap diodes.
- For lower-leg IGBTs : Advanced input filter, Shoot through prevention, Drive circuit, Control supply under-voltage protection (UV), Short circuit protection (SC).
- Fault signaling : Corresponding to an SC fault, a UV fault (Lower-side supply).
- Input interface: 3V, 5V line(High Active).
- Analog temperature output.

APPLICATION

AC100V~220V inverter drive for small power motor control, such as: DC Fan、 Inverter air-conditioner、 industrial sewing machine etc.

Detailed Package Outline Drawings:

Dimensions in mm

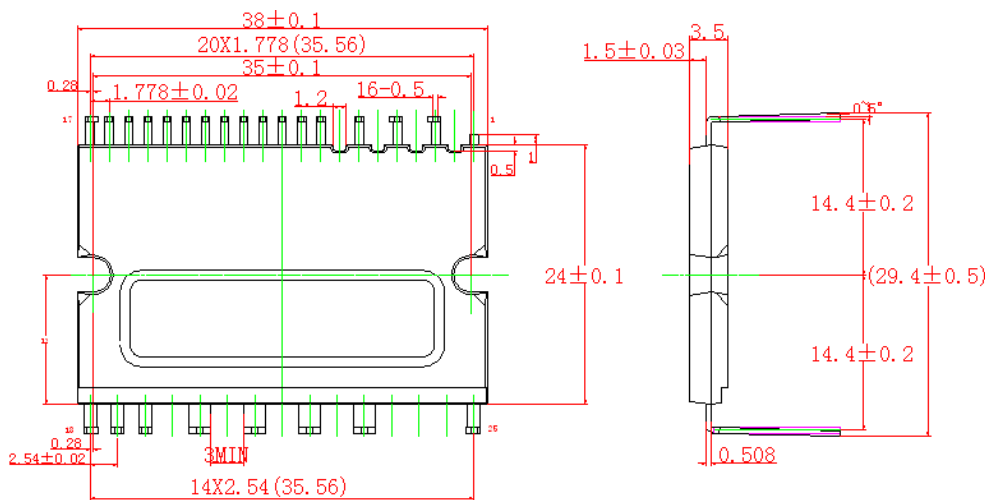

TERMINAL CODE

1. NC
2. VUFB
3. VVFB
4. VWFB
5. UP
6. VP
7. WP
8. VP1
9. VNC *
10. UN
11. VN
12. WN
13. VN1
14. FO
15. CIN
16. VNC *
17. VOT
18. NW
19. NV
20. NU
21. W
22. V
23. U
24. P
25. NC

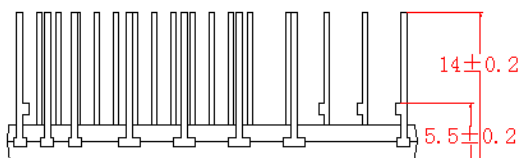

Heatsink side

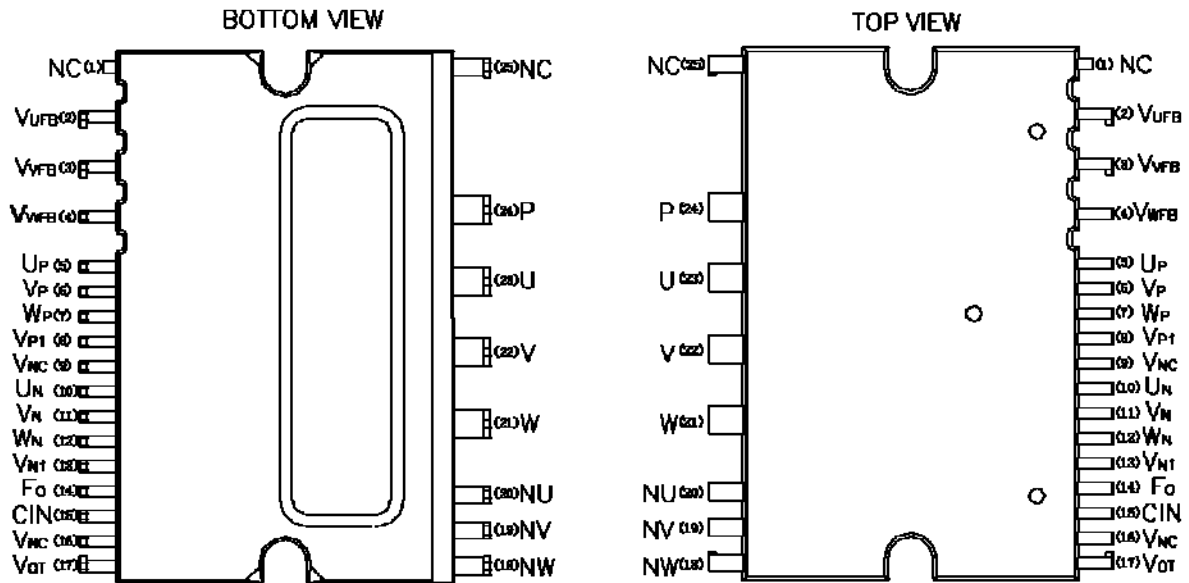
SPE20S60F-ATRANSFER-MOLD TYPE
FULL PACK TYPE**Pin Configuration****Figure 2 .Pin Configuration****Pin Descriptions**

Pin number	Pin name	Pin Description
1	NC	No connection
2	VUFB	U-phase high side floating IC supply voltage
3	VVFB	V-phase high side floating IC supply voltage
4	VWFB	W-phase high side floating IC supply voltage
5	UP	U-phase high side gate driver input
6	VP	V-phase high side gate driver input
7	WP	W-phase high side gate driver input
8	VP1	IC supply voltage
9	VNC	Common Supply Ground
10	UN	U-phase low side gate driver input
11	VN	V-phase low side gate driver input
12	WN	W-phase low side gate driver input
13	VN1	IC supply voltage
14	Fo	Fault output
15	CIN	Analog input for over current shutdown
16	VNC	Common Supply Ground
17	VOT	Temperature Output
18	NW	Negative DC-Link input for W-phase
19	NV	Negative DC-Link input for V-phase
20	NU	Negative DC-Link input for U-phase
21	W	Motor W-phase output
22	V	Motor V-phase output
23	U	Motor U-phase output
24	P	Positive bus input voltage
25	NC	No connection

SPE20S60F-A

TRANSFER-MOLD TYPE
FULL PACK TYPE

Internal Function Block Diagram

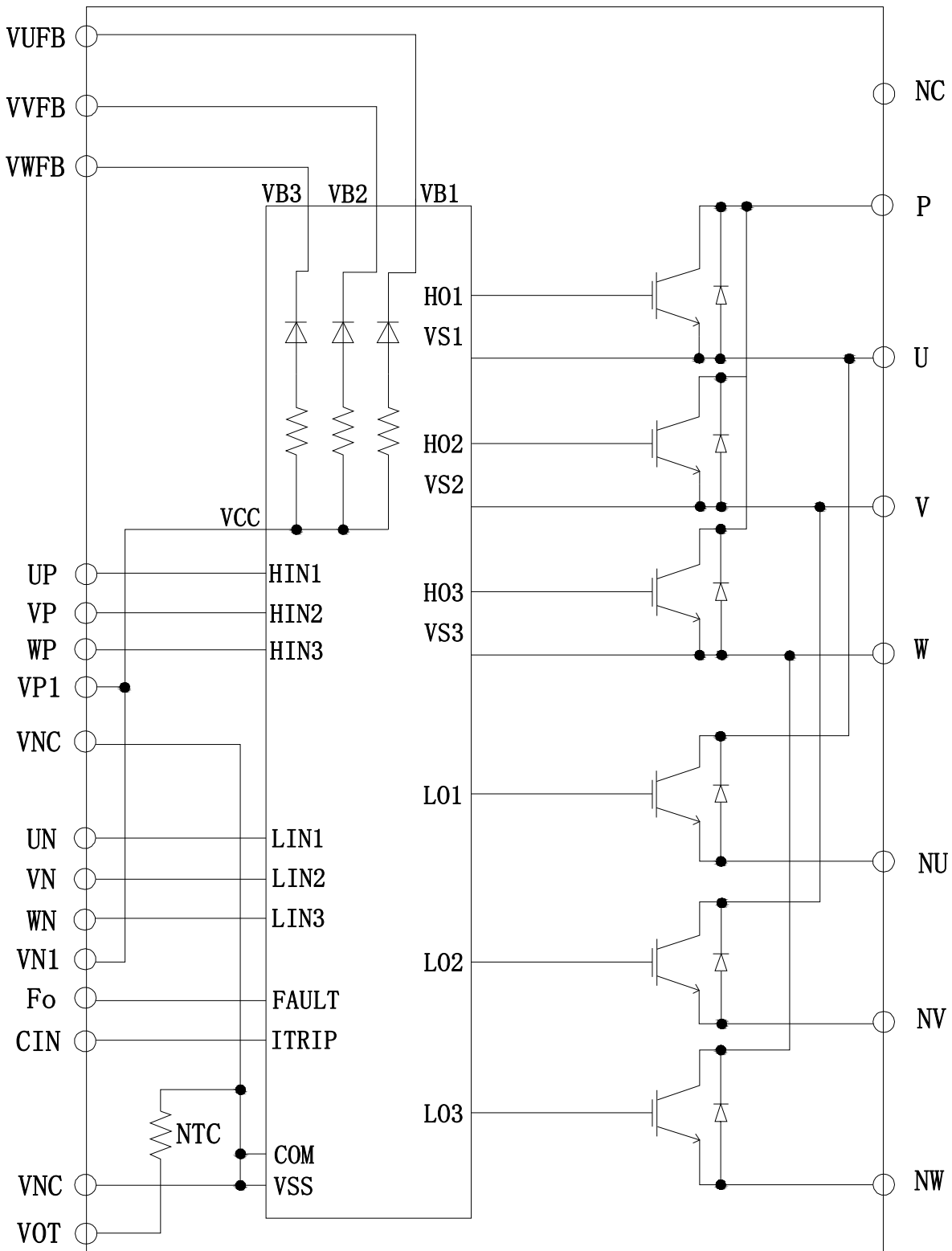

Figure 3 . Function Block Diagram

Absolute Maximum Ratings (T_j= 25°C, Unless Otherwise Specified)**Inverter Part**

Symbol	Parameter	Conditions	Ratings	Unit
V _{CC}	Supply Voltage	Applied between P- NU, NV, NW	450	V
V _{CC(Surge)}	Supply Voltage (Surge)	Applied between P- NU, NV, NW	500	V
V _{CES}	Collector-emitter Voltage		600	V
± I _C	Each IGBT Collector Current	T _C = 25°C	20	A
± I _{CP}	Each IGBT Collector Current (Peak)	T_C = 25°C, Less than 1ms	40	A
P _C	Collector Dissipation	T _C = 25°C Per One Chip	34	W
T _j	Operating Junction Temperature	(Note 1)	-40 ~ +150	°C

Note:

- The maximum junction temperature rating of the power chips integrated within the IPM is 175°C(@T_C ≤ 100°C). However, to insure safe operation of the IPM, the junction temperature should be limited to T_{j(av)} ≤ 150°C (@T_C ≤ 100°C).

Control Part

Symbol	Parameter	Conditions	Ratings	Unit
V _{DB}	High side floating supply voltage	Applied between UFB - U, VFB-V, WFB-W	17.5	V
V _D	Low side supply voltage	Applied between VP1, VN1 - V _{NC}	17.5	V
V _{IN}	Input Signal Voltage	Applied between UP, VP, WP, UN, VN, WN - V _{NC}	-1~10	V
V _{FO}	Fault Output Supply Voltage	Applied between F _O - V _{NC}	-0.5~VD+0.5	V
I _{FO}	Fault Output Current	Sink Current at F _O Pin	1.5	mA
V _{SC}	Current Sensing Input Voltage	Applied between CIN - V _{NC}	-1~10	V

Total System

Symbol	Parameter	Conditions	Ratings	Unit
V _{CC(PROT)}	Self Protection Supply Voltage Limit(Short Circuit Protection Capability)	V _D = V _{DB} = 13.5 ~ 16.5V T _j = 150°C, Non-repetitive, less than 2us	400	V
T _C	Module Case Operation Temperature	-20°C ≤ T _j ≤ 150°C,	-20 ~ +100	°C
T _{STG}	Storage Temperature		-40 ~ +150	°C
V _{ISO}	Isolation Voltage	60Hz, Sinusoidal, AC 1 minute, between Pins and heat-sink plate	2500	V _{rms}

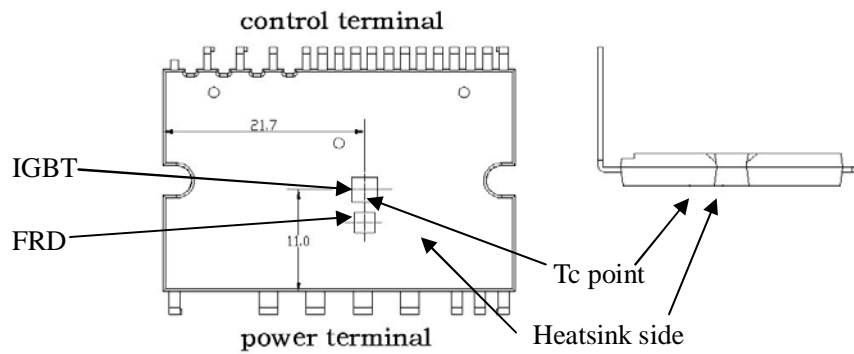

Figure 4. Tc measurement point

Thermal Resistance

Symbol	Parameter	Conditions	Min.	Typ.	Max.	Unit
Rth(j-c)Q	Junction to Case Thermal Resistance	Inverter IGBT part (per 1/6 module)	-	-	3.6	°C/W
Rth(j-c)F		Inverter FWD part (per 1/6 module)	-	-	4.8	°C/W

Electrical Characteristics (T_j = 25°C, Unless Otherwise Specified)**Inverter Part**

Symbol	Parameter	Conditions	Min.	Typ.	Max.	Unit
V _{CE(SAT)}	Collector - Emitter Saturation Voltage	V _D = V _{DB} = 15V V _{IN} = 5V, I _C = 20A, T _j = 25°C	-	1.70	-	V
		V _D = V _{DB} = 15V V _{IN} = 5V, I _C = 20A, T _j = 125°C	-	2.0	-	V
V _F	FWD Forward Voltage	V _{IN} = 0V, I _C = -20A, T _j = 25°C	-	1.5	-	V
		V _{IN} = 0V, I _C = -20A, T _j = 125°C	-	1.4	-	V
t _{ON}	Switching Times	V _{PN} = 300V, V _D = V _{DB} = 15V I _C = 20A V _{IN} = 0V -5V, Inductive Load	-	0.75	-	μs
t _{c(ON)}			-	0.12	-	μs
t _{OFF}			-	0.90	-	μs
t _{c(OFF)}			-	0.08	-	μs
t _{tr}			-	0.18	-	μs
I _{CEs}	Collector-Emitter Leakage Current	V _{CE} = V _{CEs} T _j = 25°C	-	-	75	μA
		V _{CE} = V _{CEs} T _j = 125°C	-	-	1	mA

Note:

2. t_{ON} and t_{OFF} include the propagation delay time of the internal drive IC. t_{c(ON)} and t_{c(OFF)} are the switching time of IGBT itself under the given gate driving condition internally. For the detailed information, please see Figure 5.

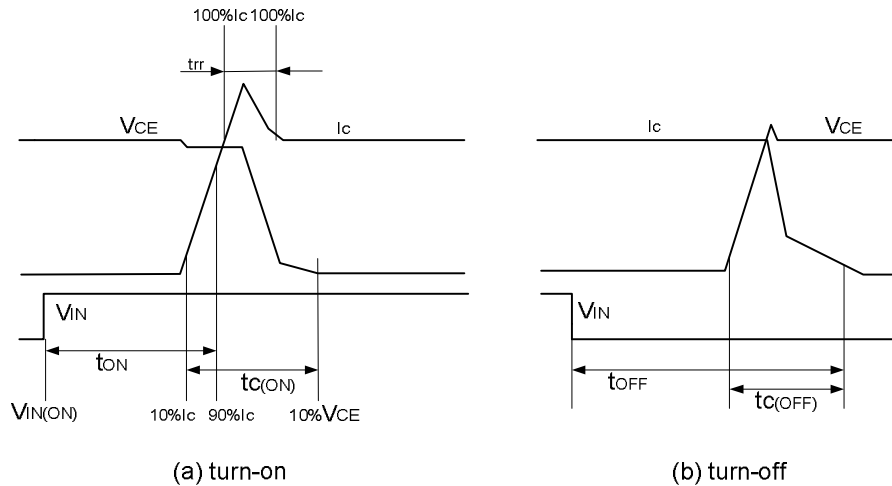
SPE20S60F-ATRANSFER-MOLD TYPE
FULL PACK TYPE**Figure 5 . Switching Time Definition****Electrical Characteristics** ($T_j = 25^\circ\text{C}$, Unless Otherwise Specified)**Control Part**

Symbol	Parameter	Condition		Min.	Typ.	Max.	Units
I_D	Quiescent V_D Supply Current	$V_D = 15\text{V}$ $V_{IN} = 5\text{V}$	VP1, VN1-VNC	-	0.52	1	mA
I_{DB}	Quiescent V_{DB} Supply Current	$V_{DB} = 15\text{V}$ $V_{IN} = 5\text{V}$	UFB - U, VFB - V, WFB - W	-	0.36	0.55	μA
V_{FOH}	Fault Output Voltage	$V_{sc} = 0\text{V}$, F_o Terminal pull up to 5V by 10kohm		4.9	-	-	V
V_{FOL}		$V_{sc} = 1\text{V}$, $I_{FO} = 1.5\text{mA}$		-	-	1.05	V
$V_{sc,TH+}$	Short circuit positive going threshold	$V_D = 15\text{V}$ (Note 3)		0.37	0.46	0.55	V
$V_{sc,TH-}$	Short circuit negative going threshold	$V_D = 15\text{V}$		-	0.4	-	V
$UVDt$	Control supply under-voltage protection	Trip Level		9.5	10.4	11.0	V
$UVDr$		Reset Level		11	12.1	12.8	
$UVDBt$		Trip Level		9.5	10.4	11.0	
$UVDBr$		Reset Level		11	12.1	12.8	
$R_{on,FLT}$	FLT low on resistance	$I = 1.5\text{mA}$			50	90	ohm
t_{FO}	Fault-out Pulse Width			20	-	-	us
$t_{FIL,IN}$	Input filter time (U/V/WP, U/V/WN, CIN)	$V_{IN} = 0\text{V}$ & 5V		140	290	-	ns
t_{BL}	CIN blanking time	$V_{IN} = 0\text{V}$ or 5V , $V_{CIN} = 5\text{V}$		-	400	-	ns
$V_{IN(ON)}$	ON Threshold Voltage	Applied between $U_P, V_P, W_P, U_N, V_N, W_N$ - VNC		1.7	2.1	2.4	V
$V_{IN(OFF)}$	OFF Threshold Voltage			0.7	0.85	1.1	
VOT	Temperature output Note 4	IC Temperature= 90°C		2.63	2.77	2.91	V
		IC Temperature= 25°C		0.88	1.13	1.39	
BSD Forward voltage	V_F	$I_F = 10\text{mA}$ including voltage		-	1.0	1.3	V
BSD current limiting resistor	R			22	36	50	ohm

Note: 3. Short-circuit current protection is functioning at both low-side and high side.

SPE20S60F-ATRANSFER-MOLD TYPE
FULL PACK TYPE

Note:4. IPM do not shutdown IGBTs and output fault signal automatically when temperature rises excessively. When temperature exceeds the protective level the user defined, controller(MCU)should stop the IPM. Temperature of HVIC vs VoT output characteristics is described as Fig 6.

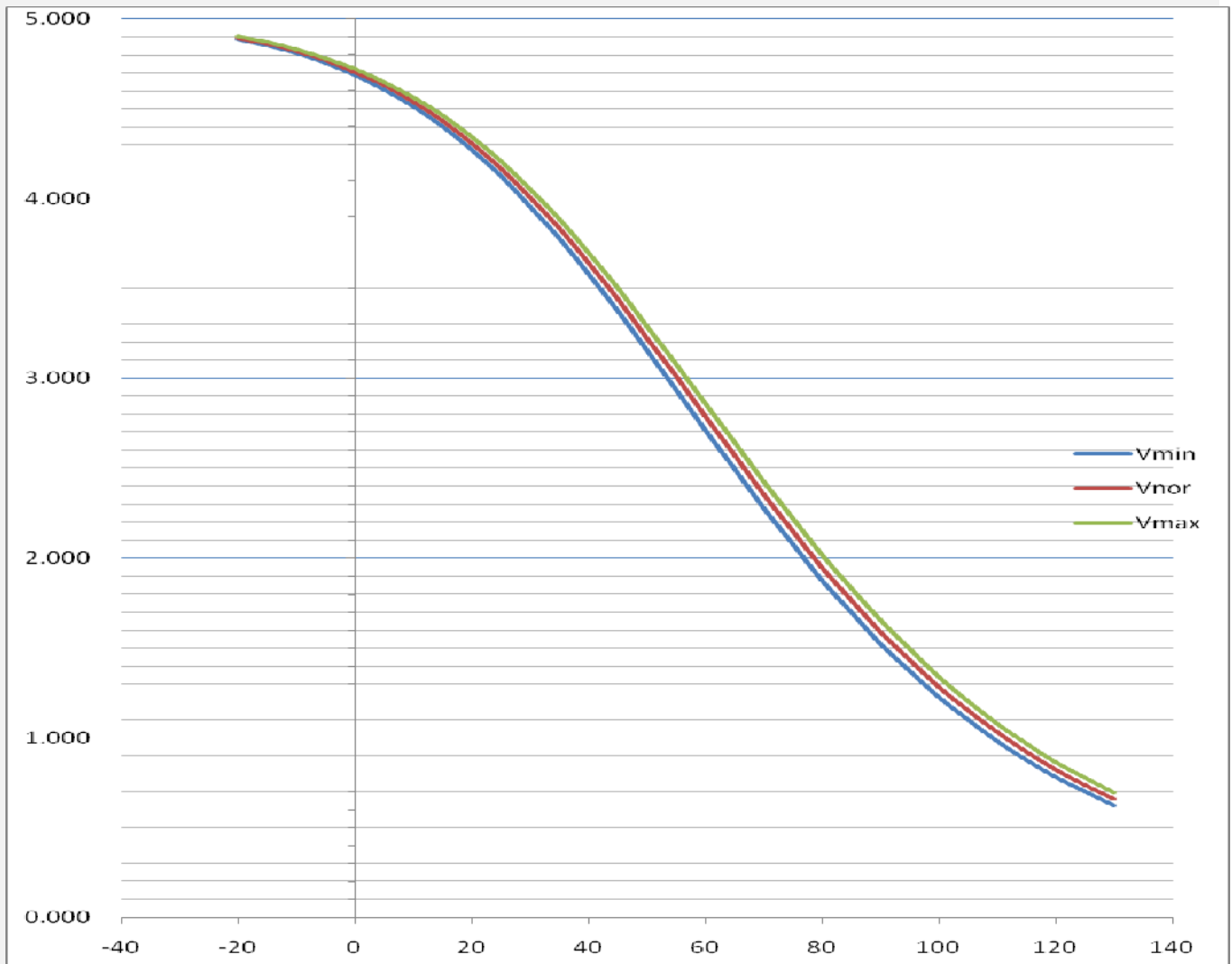

Figure 6. VOT output voltage VS HVIC temperature

Recommended Operating Conditions

Symbol	Parameter	Conditions	Values			Unit
			Min.	Typ.	Max.	
V _{CC}	Supply Voltage	Applied between P - NU, NV, NW	-	300	400	V
V _D	Control Supply Voltage	Applied between VP1, VN1 - VNC	-	15	-	V
V _{DS}	High-side Bias Voltage	Applied between V _{UFB} - U, V _{VFB} - V, V _{WFB} - W	-	15	-	V
t _{dead}	Blanking Time for Preventing Arm-short	For Each Input Signal	1.5	-	-	us
f _{PWM}	PWM Input Signal	-20°C ≤ T _C ≤ +100°C, -20°C ≤ T _J ≤ +150°C	-	-	20	kHz
P _{WIN(ON)}	Minimum Input Pulse Width		1	-	-	us
P _{WIN(OFF)}			1	-	-	us
T _J	Junction temperature		-20	-	125	° C

Internal NTC - Thermistor Characteristics

symbol	parameter	conditions	Values			unit
			Min	Typ	Max	
RNTC	Resistance of Thermistor	TNTC = 25°C see Figure 15.	98	100	102	Kohm
		TNTC = 125°C	3.43	3.58	3.75	Kohm
Temperature Range			-40	-	+125	°C

Mechanical Characteristics and Ratings

Parameter	Conditions	Limits			Unit
		Min.	Typ.	Max.	
Mounting Torque	Mounting Screw: - M3	-	0.69	-	N•m
Device Flatness	see Figure 7.	0	-	+120	um
Weight		-	7	-	g

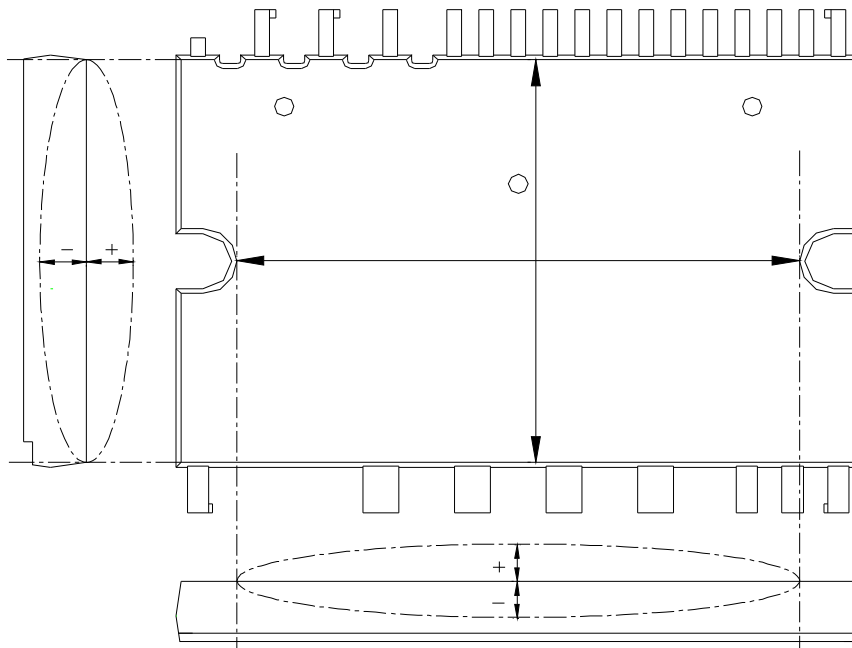
**Figure 7. Flatness Measurement Position****Advanced input filter**

The advanced input filter allows an improvement in the input/output pulse symmetry of HVIC inside the module and helps to reject noise spikes and short pulses. The advantage of the new filter is shown in Figures 8 and 9.

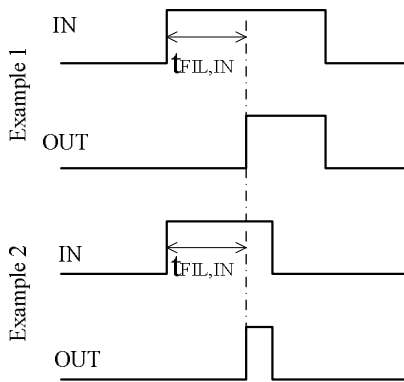

Figure 8. Typical input filter

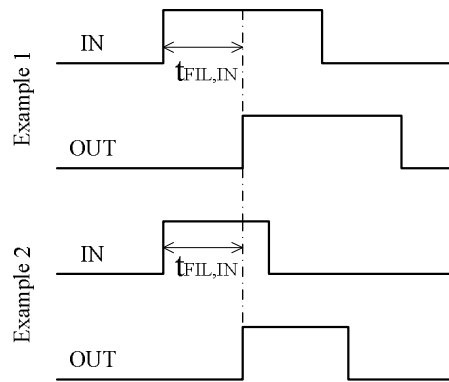

Figure 9. Advanced input filter

Time Charts of Protective Function

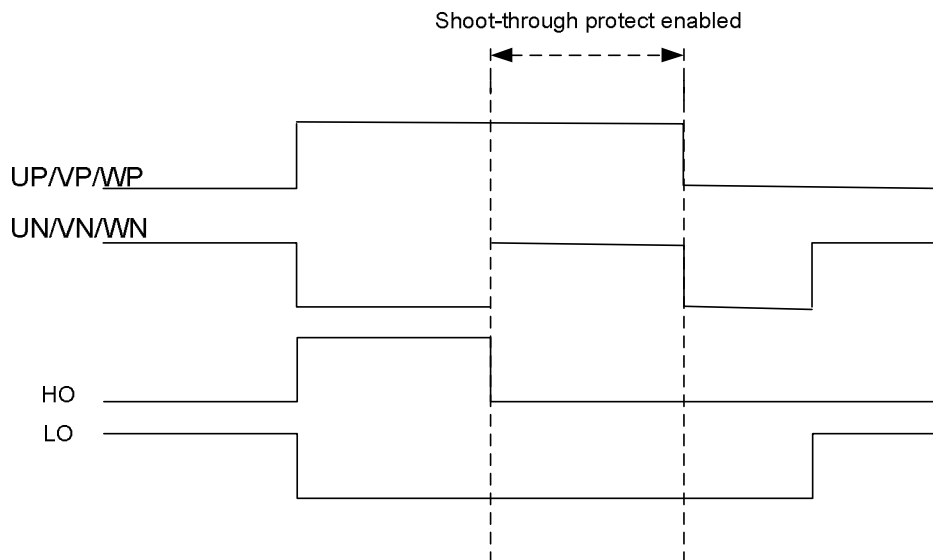

Figure 10 . Shoot-through (cross-conduction) protection

Note:

5. The signal HO and LO are gate output of the internal HVIC.

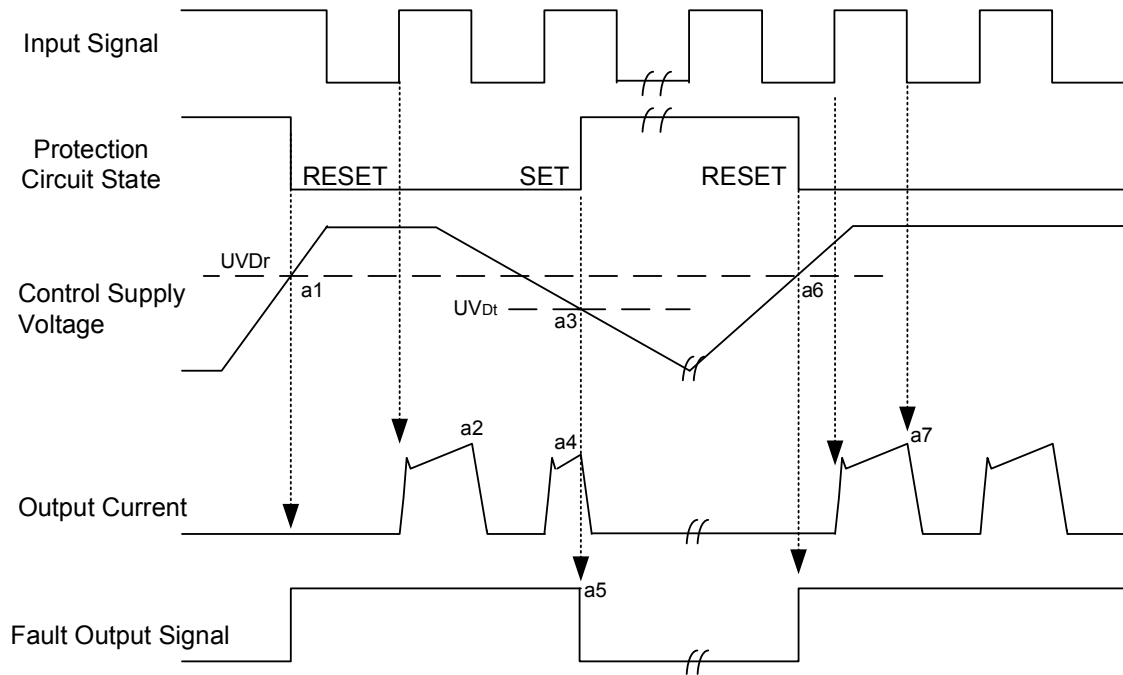

Figure 11. Under-Voltage Protection (Low-side Operation)

- a1 : Control supply voltage rises: After the voltage rises UV_{Dr} , the circuits start to operate when next input is applied.
- a2 : Normal operation: IGBT ON and carrying current.
- a3 : Under voltage detection (UV_{Dt}).
- a4 : IGBT OFF in spite of control input condition.
- a5 : Fault output operation starts.
- a6 : Under voltage reset (UV_{Dr}).
- a7 : Normal operation: IGBT ON and carrying current.

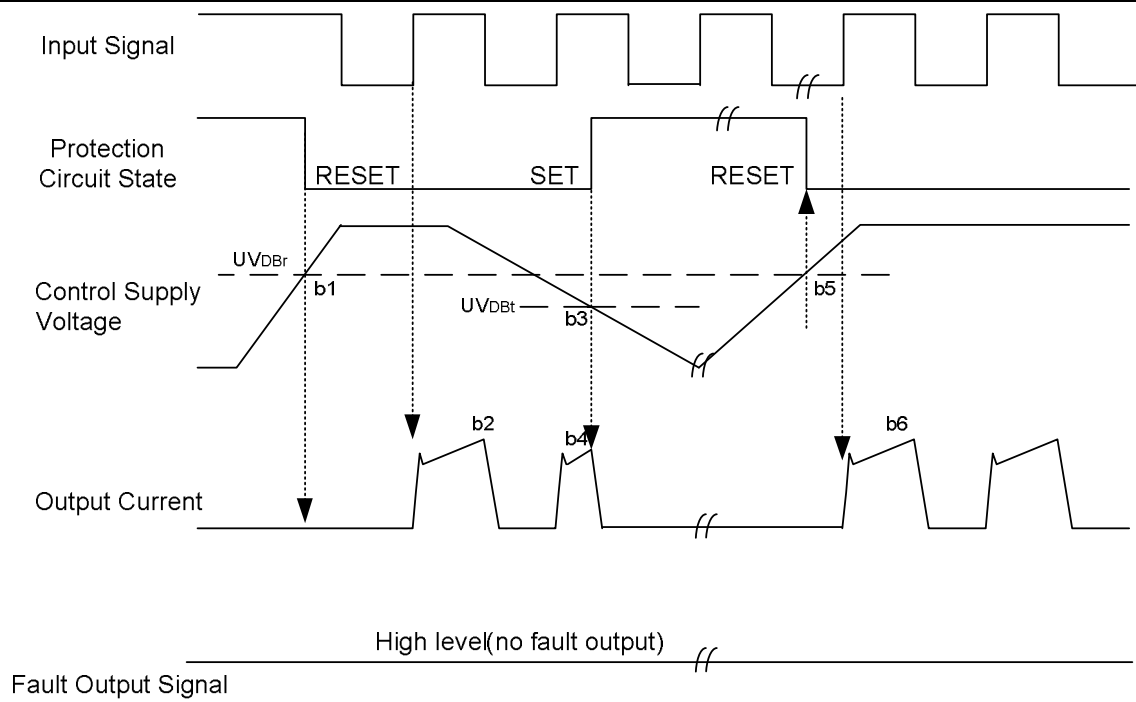

Figure 12. Under-Voltage Protection (High-side Operation only)

- b1 : Control supply voltage rises: After the voltage reaches UV_{DBr} , the circuits start to operate when next input is applied.
- b2 : Normal operation: IGBT ON and carrying current.
- b3 : Under voltage detection (UV_{DBt}).
- b4 : IGBT OFF in spite of control input condition, but there is no fault output signal.
- b5 : Under voltage reset (UV_{DBr}).
- b6 : Normal operation: IGBT ON and carrying current.

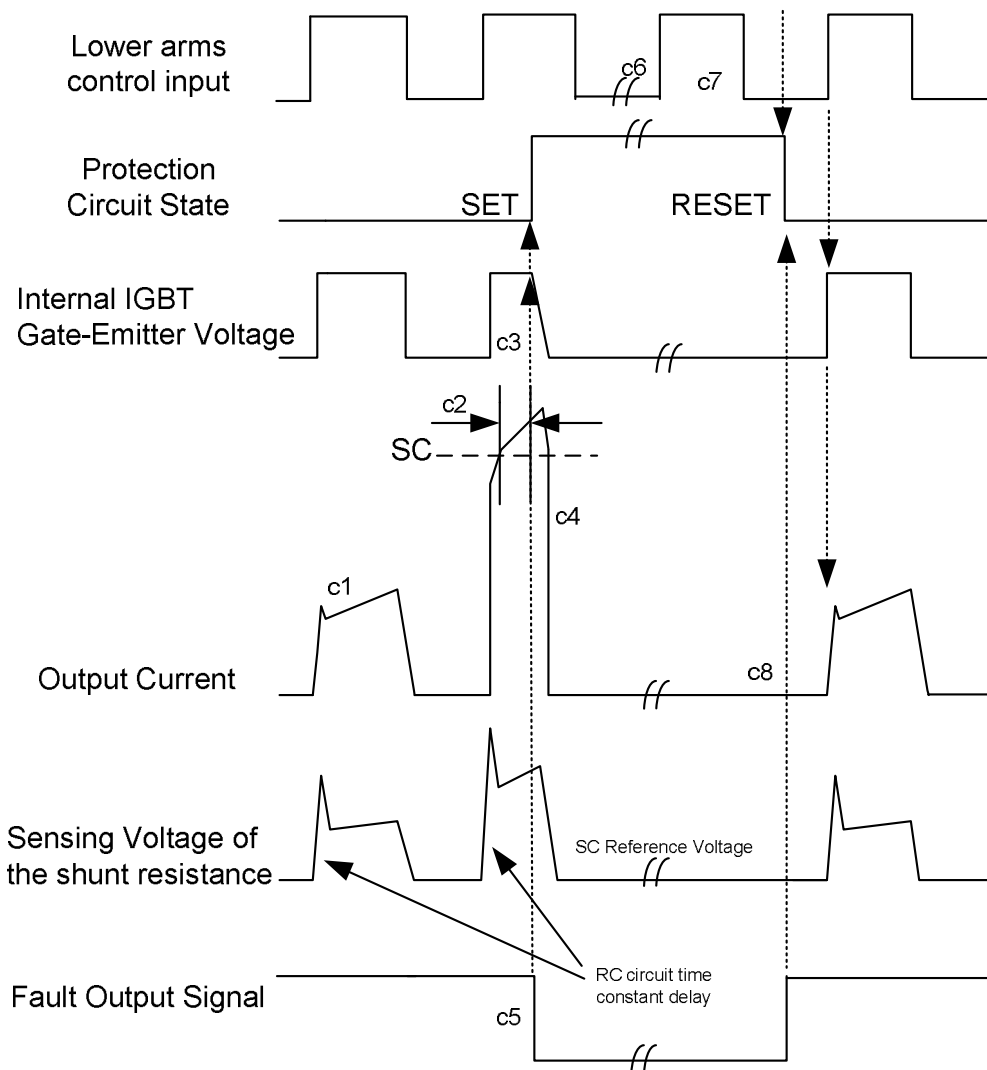

Figure 13. Short-Circuit Current Protection (Low-side And High-side Operation)

(with the external shunt resistance connection)

c1 : Normal operation: IGBT ON and carrying current.

c2 : Short circuit current detection (CIN trigger).

c3 : Hard IGBT gate interrupt.

c4 : IGBT turns OFF.

c5 : Fault output timer operation starts: The pulse width of the fault output signal is set by the internal capacitor.

c6 : Input "L" : IGBT OFF state.

c7 : Input "H": IGBT ON state, but during the active period of fault output the IGBT doesn't turn ON.

c8 : IGBT OFF state

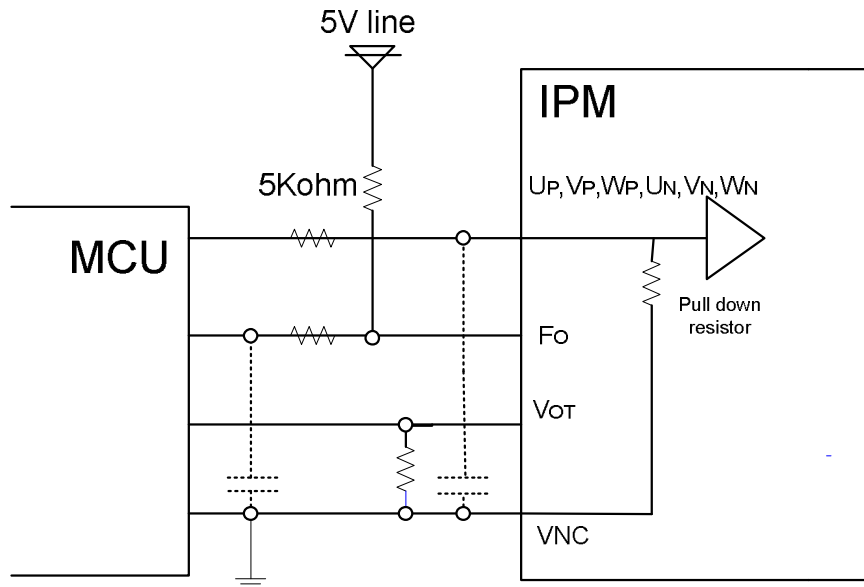
Input/Output Interface Circuit**Figure 14. Recommended CPU I/O Interface Circuit****Note:**

6. RC coupling at each input (parts shown dotted) might change depending on the PWM control scheme used in the application and the wiring impedance of the application's printed circuit board.
7. The logic input is compatible with standard CMOS or LSTTL outputs

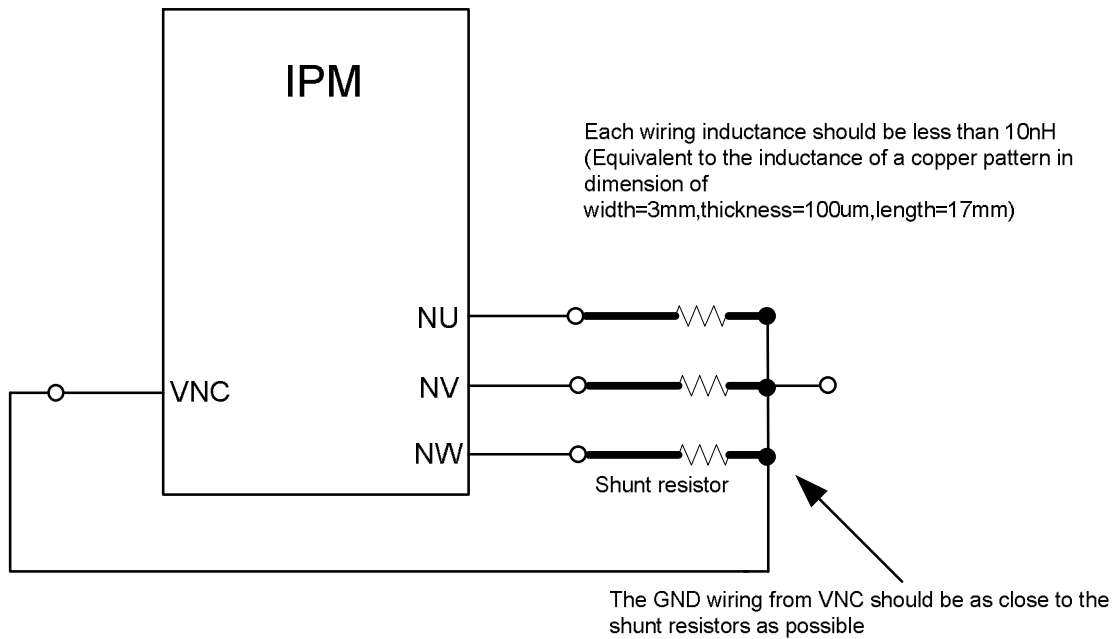
Wiring Around The Shunt Resistor**Figure 15. Recommended Wiring Around The Shunt Resistor**

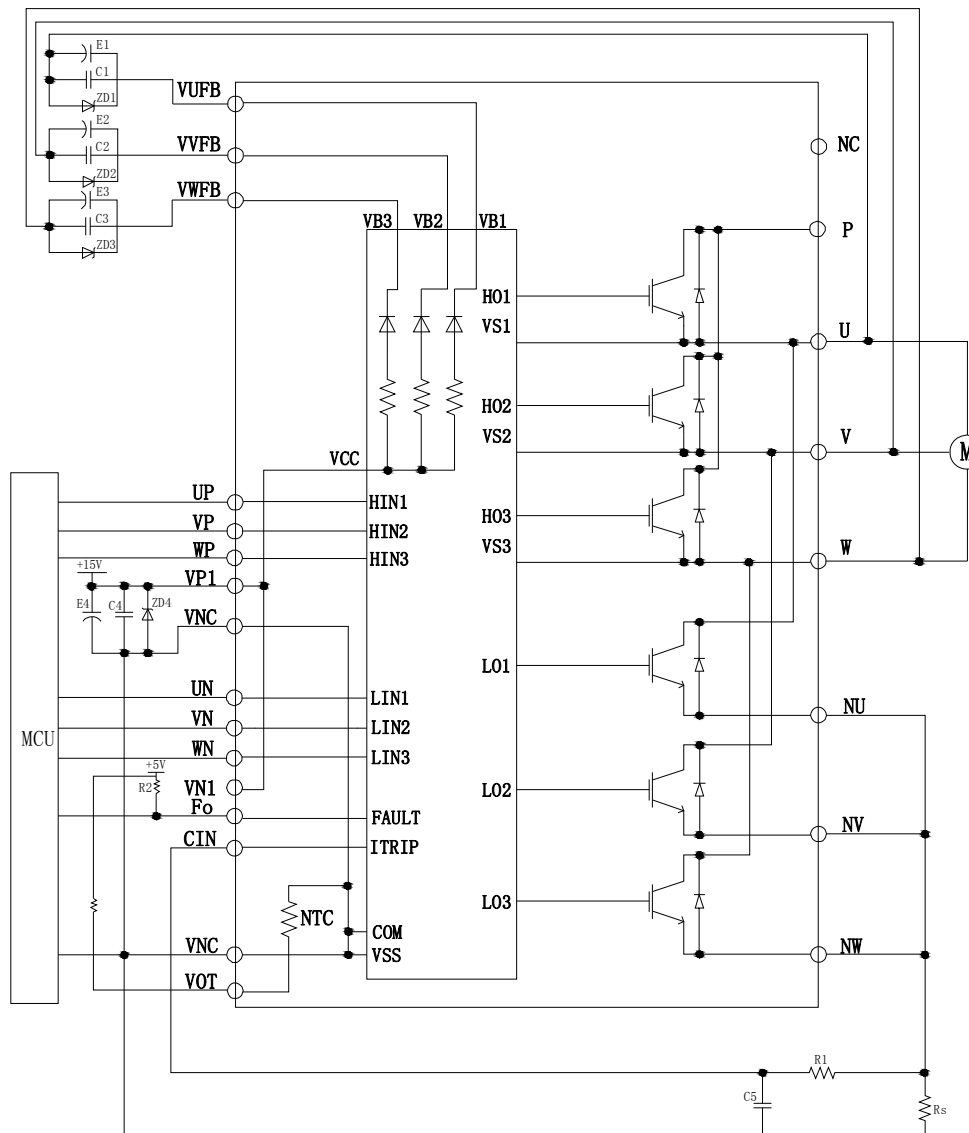
**Figure 16. Typical Application Circuit****Note:**

8. Input drive is High-Active type. There is a 34k Ω (typ.) pull-down resistor integrated in the IC input circuit. To prevent malfunction, the wiring of each input should be as short as possible. When using RC coupling circuit, make sure the input signal level meet the turn-on and turn-off threshold voltage.
9. Thanks to HVIC inside the module, direct coupling to MCU without any opto-coupler or transformer isolation is possible
10. Bootstrap negative electrodes should be connected to U, V, W terminals directly and separated from the main output wires
11. Fo output is open drain type. It should be pulled up to the positive side of a 5V power supply by a resistor of about 10k Ω .
12. To prevent erroneous protection, the wiring of A, B, C should be as short as possible.
13. The time constant R1C4 of the protection circuit should be selected in the range of 1.5-2 μ s. SC interrupting time might vary with the wiring pattern. Tight tolerance, temp-compensated type is recommended for R1, C4.
14. All capacitors should be mounted as close to the terminals of the IPM as possible. (C1: good temperature, frequency characteristic electrolytic type, and C2, C3: good temperature, frequency and DC bias characteristic ceramic type are recommended.)
15. To prevent surge destruction, the wiring between the smoothing capacitor and the P, N1 terminals should be as short as possible. Generally a 0.1-0.22 μ F snubber between the P-N1 terminals is recommended.
16. Two VNC terminals (9 & 16 pin) are connected inside IPM, please connect either one to the 15V power supply GND outside and leave another one open.
17. It is recommended to insert a Zener diode (24V/1W) between each pair of control supply terminals to prevent surge destruction.
18. If control GND is connected to power GND by broad pattern, it may cause malfunction by power GND fluctuation. It is recommended to connect control GND and power GND at only one point.