

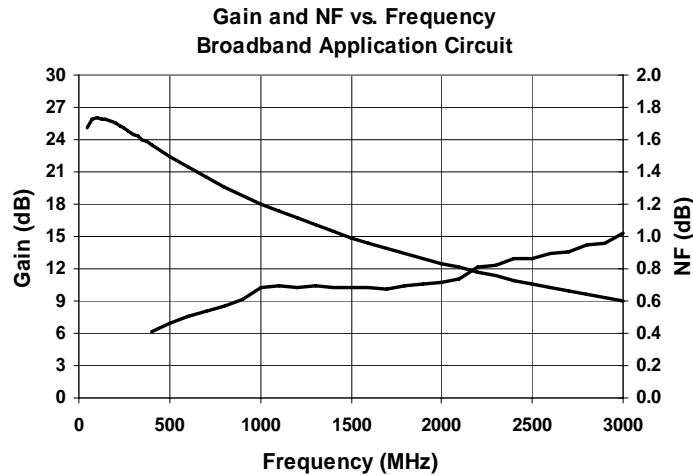

## Product Description

The SPF-5122Z is a high performance pHEMT MMIC LNA designed for operation from 400-3000 MHz. The on-chip active bias network provides stable current over temperature and process threshold voltage variations. The SPF-5122Z offers ultra-low noise figure and high linearity performance in a gain block configuration. Its single-supply operation and integrated matching networks make implementation remarkably simple. High maximum input power specification make it ideal for high dynamic range receivers.



## Advanced Information

# SPF-5122Z

## 400-3000 MHz, GaAs pHEMT Low Noise MMIC Amplifier

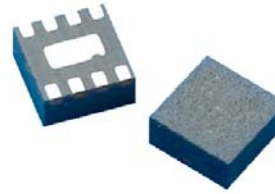

### Product Features

- Ultra-Low Noise Figure = 0.6dB @ 900MHz
- Gain = 19dB @ 900MHz
- High Linearity: OIP<sub>3</sub> = 40.5dBm @ 1900MHz
- P1dB = 24dBm @ 1900MHz
- Single Supply Operation: 5V @ Idq=90mA
- Broadband Internal Matching
- Small Package: QFN 2x2
- RoHS/WEEE Compliant Package

### Applications

- Cellular, PCS, DCS1800, CDMA, WCDMA Receivers
- Low noise, high linearity gain block applications

Symbol	Parameters	Units	Frequency	Min.	Typ.	Max.
S <sub>21</sub>	Small Signal Power Gain	dB	0.9 GHz		18.8	
			1.9 GHz		13.0	
NF	Noise Figure	dB	0.9 GHz		0.65	
			1.9 GHz		0.70	
OIP <sub>3</sub>	Output Third Order Intercept Point	dBm	0.9 GHz		38.5	
			1.9 GHz		40.5	
P1dB	Output Power at 1dB Compression	dBm	0.9 GHz		23.0	
			1.9 GHz		23.8	
S <sub>11</sub>	Input Return Loss	dB	0.9 GHz		-14.0	
			1.9 GHz		-19.0	
S <sub>22</sub>	Output Return Loss	dB	0.9 GHz		-16.5	
			1.9 GHz		-12.5	
S <sub>12</sub>	Reverse Isolation	dB	0.9 GHz		-24.0	
			1.9 GHz		-18.5	
V <sub>D</sub>	Device Operating Voltage	V			5.0	
I <sub>D</sub>	Device Operating Current	mA			90	
R <sub>th, j-l</sub>	Thermal Resistance (junction-to-Lead)	°C/W			65	

**Test Conditions:** V<sub>S</sub> = 5.0V, I<sub>DQ</sub> = 90mA, OIP<sub>3</sub> Tone Spacing = 1MHz, P<sub>out</sub> per tone = 0 dBm

Z<sub>S</sub> = Z<sub>L</sub> = 50 Ohms, 25C, Broadband Application Circuit

The information provided herein is believed to be reliable at press time. Sirenza Microdevices assumes no responsibility for inaccuracies or omissions. Sirenza Microdevices assumes no responsibility for the use of this information, and all such information shall be entirely at the user's own risk. Prices and specifications are subject to change without notice. No patent rights or licenses to any of the circuits described herein are implied or granted to any third party. Sirenza Microdevices does not authorize or warrant any Sirenza Microdevices product for use in life-support devices and/or systems. Copyright 2006 Sirenza Microdevices, Inc.. All worldwide rights reserved.

**Typical RF Performance (With Broadband Application Circuit)**

Symbol	Parameter	Unit	Frequency (GHz)							
			0.4	0.8	0.9	1.0	1.9	2.2	2.5	3
S <sub>21</sub>	Small Signal gain	dB	23.5	19.5	18.8	18.0	13.0	11.6	10.6	9.1
NF	Noise Figure	dBm	0.45	0.60	0.65	0.70	0.70	0.80	0.90	1.00
OIP <sub>3</sub>	Output Third Order Intercept Point	dBm	35.0	37.5	38.5	38.5	40.5	40.5	42.0	42.0
P1dB	Output Power at 1dB compression	dB	23.0	23.0	23.0	23.3	23.5	24.0	24.0	24.0
S <sub>11</sub>	Input Return Loss	dB	-10.0	-13.5	-14.0	-15.0	-19.0	-21.5	-23.5	-22.5
S <sub>22</sub>	Output Return Loss	dB	-19.0	-17.0	-16.5	-16.0	-12.5	-12.5	-11.5	-11.0
S <sub>12</sub>	Reverse Isolation	dB	29.0	-25.0	-24.0	-23.5	-18.5	-17.5	-16.5	-15.0

**Test Conditions:** V<sub>S</sub>=5.0V I<sub>DC</sub>=90mA OIP<sub>3</sub> Tone Spacing = 1MHz Pout per tone = 0 dBm T<sub>L</sub> = 25°C Z<sub>S</sub> = Z<sub>L</sub> = 50Ohms

Reliability & Quantification Information	
Parameter	Absolute Limit
ESD Rating - Human Body Model (HBM)	Class 1B
Moisture Sensitivity (MSL)	MSL 1

This product qualification report can be downloaded at: [www.sirenza.com](http://www.sirenza.com)

Absolute Maximum Ratings	
Parameter	Absolute Limit
Max Device Current (I <sub>D</sub> )	120mA
Max Device Voltage (V <sub>D</sub> )	5.5V
Max RF Input Power	27dBm
Max Dissipated Power	660mW
Max Junction Temperature (T <sub>J</sub> )	150C
Operating Temperature Range (T <sub>L</sub> )	-40 to +85C
Max Storage Temp.	-65 to +150C

Typical RF Performance (With Broadband Application Circuit)

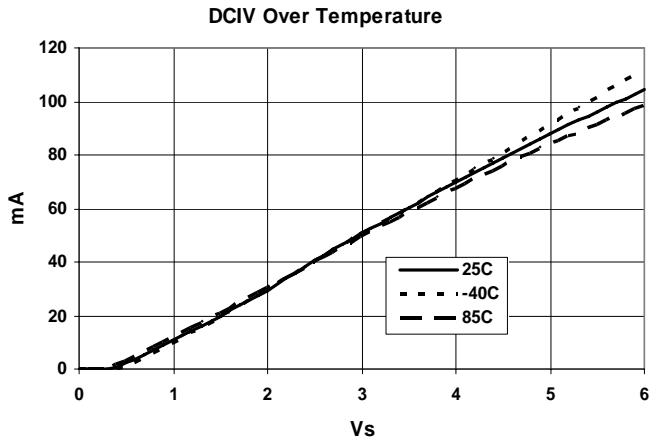

Operation of this device beyond any one of these limits may cause permanent damage. For reliable continuous operation, the device voltage and current must not exceed the maximum operating values specified in the table on page one.

Bias Conditions should also satisfy the following expression:

$$I_D V_D < (T_J - T_L) / R_{TH, j-l} \quad T_L = \text{Source Lead Temperature}$$



**Caution: ESD sensitive**

Appropriate precautions in handling, packaging and testing devices must be observed.

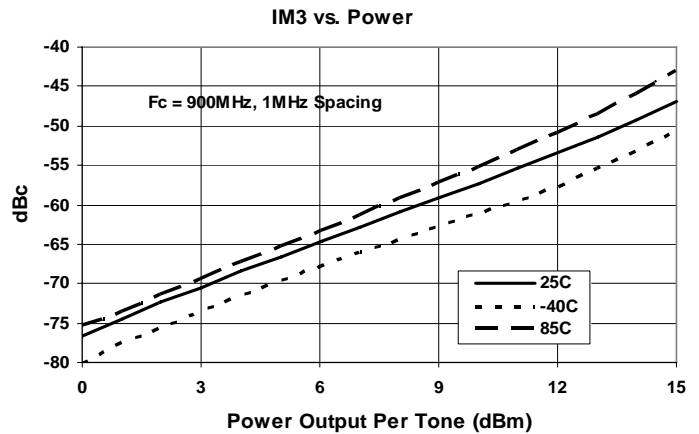
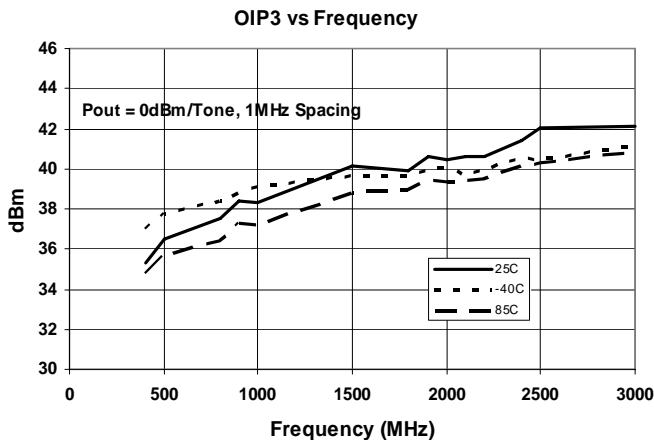

**Typical RF Performance (Broadband Application Circuit, 5V, 90mA)**

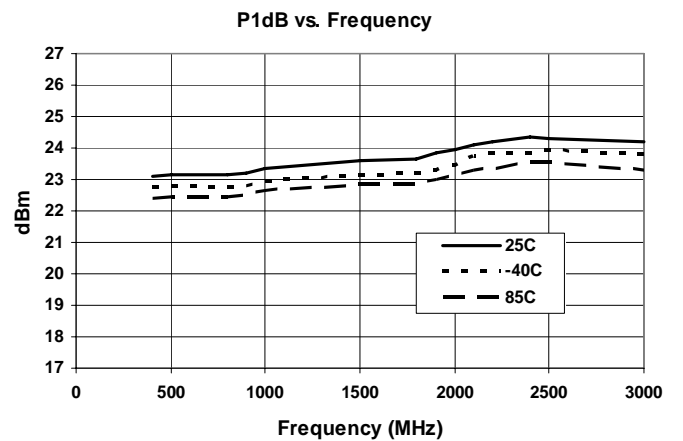
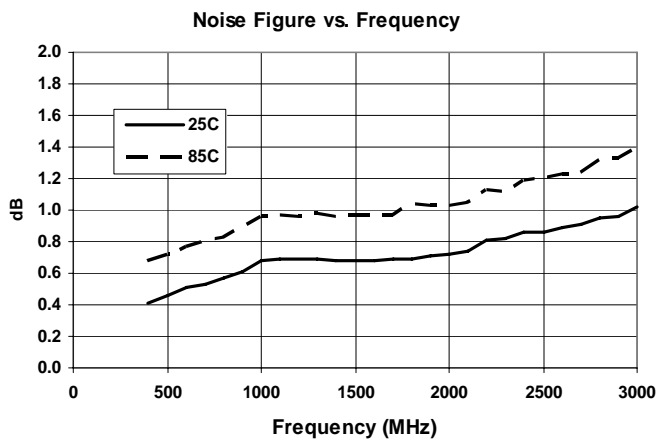
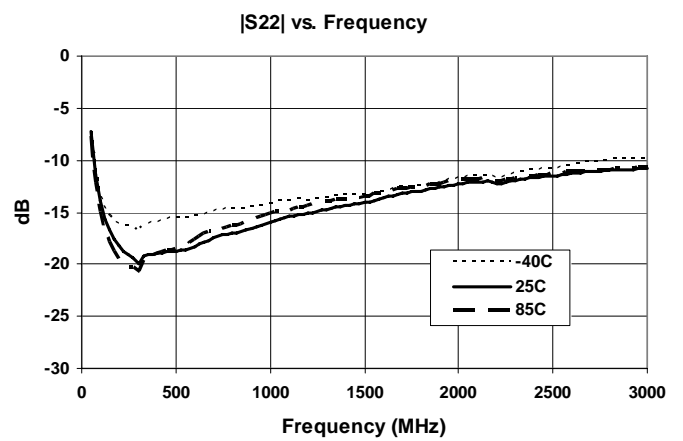
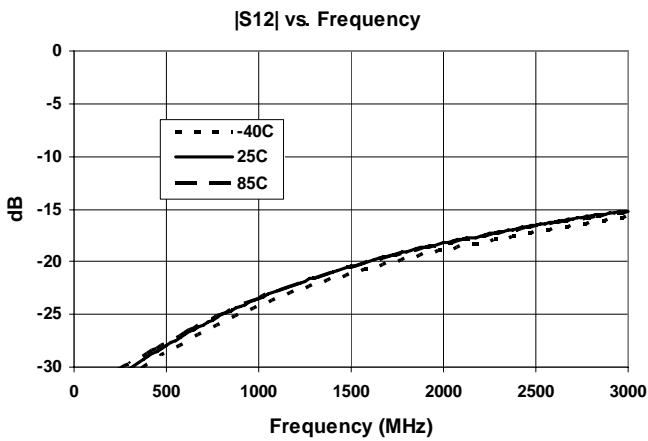
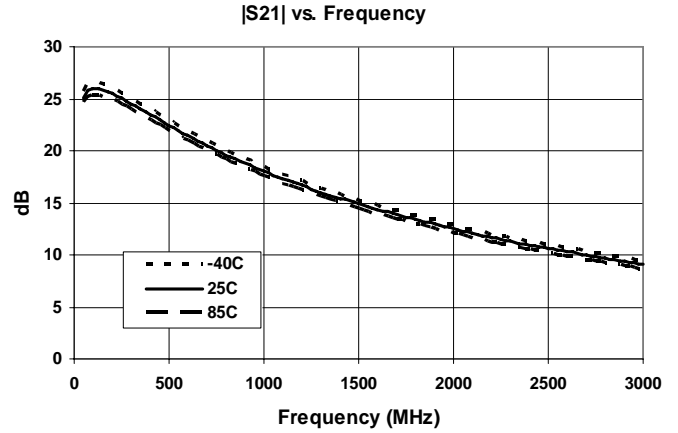
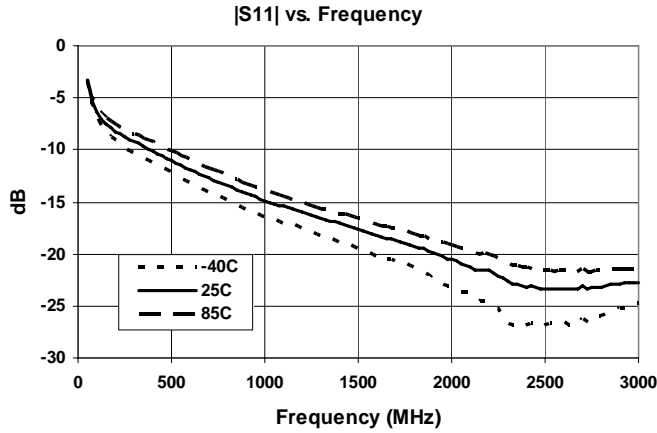

**Typical RF Performance De-embedded S-parameters (5V, 90mA)**

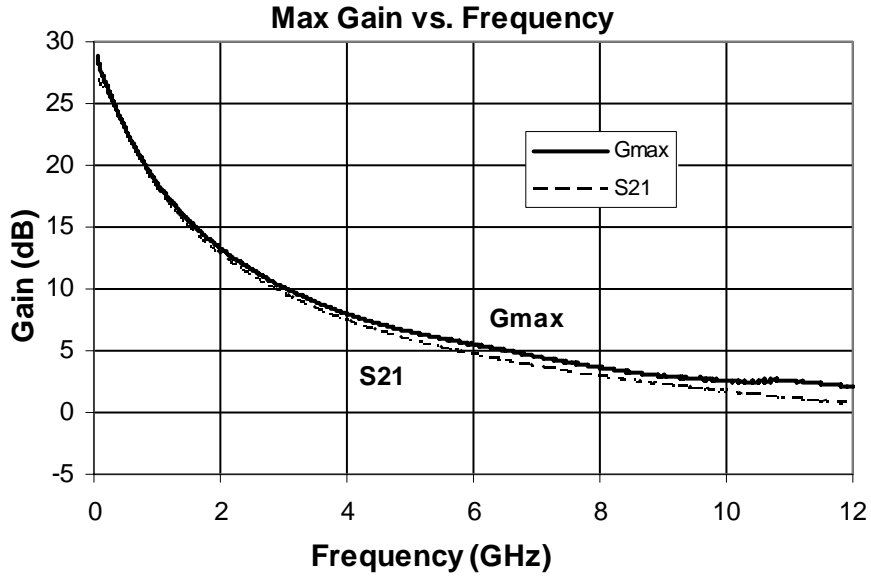

**S11 vs. Frequency**

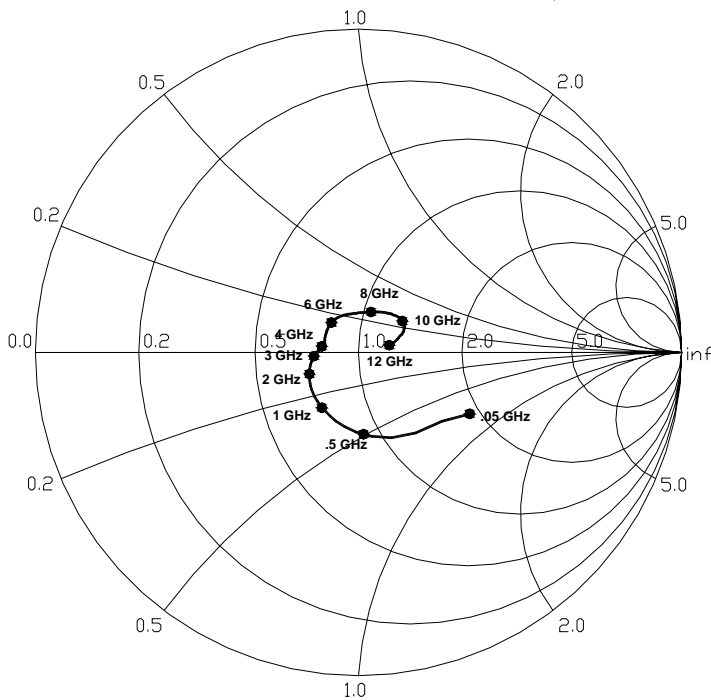

**S22 vs. Frequency**

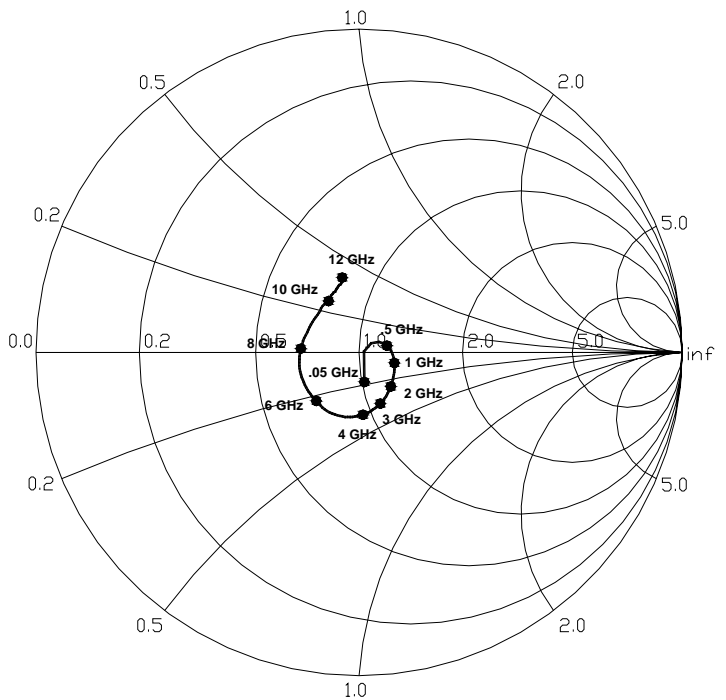

**Broadband Application Circuit (400 - 3000MHz)**

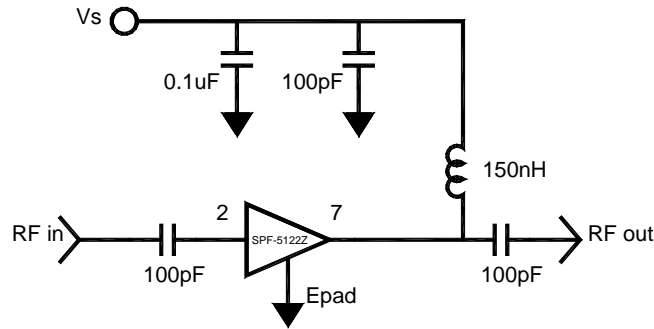

**Evaluation Board Layout**

**Bill of Materials**

- C1 1x TAJB104KLRH Rohm 0.1uF
- C2 1x MCH185A101JK Rohm 100pF
- C3 1x MCH185A101JK Rohm 100pF
- C4 1x MCH185A101JK Rohm 100pF
- L1 1x LL1608-FSR15J Toko 150nH

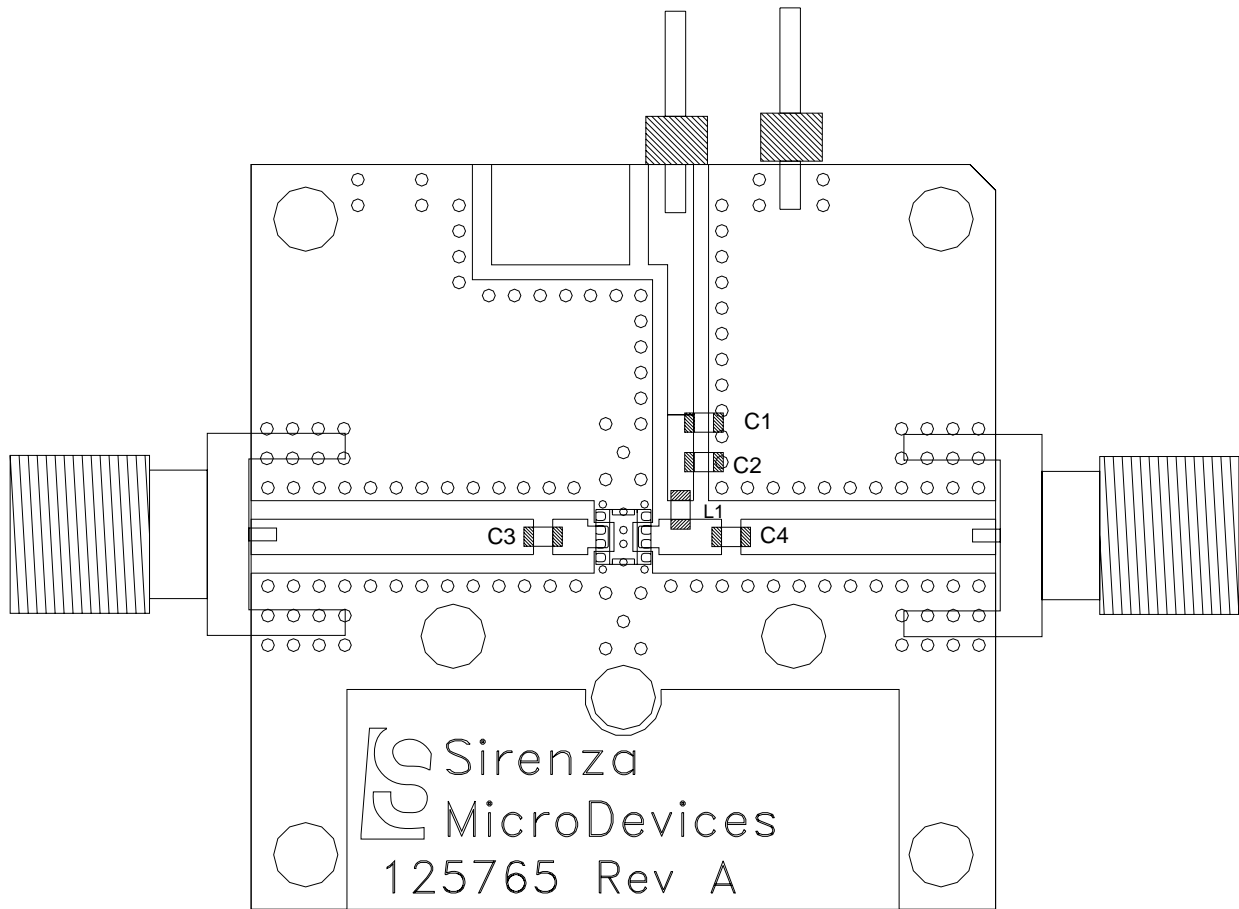

Pad #	Function	Description
1, 4, 5, 8	N/A	Ground or No Connect. Ground recommended.
2, 3	RF <sub>IN</sub>	RF input pins. These pins are DC coupled and matched to 50 Ohms. An external DC block is required.
6, 7	RF <sub>OUT</sub> / Bias	RF output and Bias pins. These pins are DC coupled and matched to 50 Ohms. Bias is applied through these pads.
EPAD	GND	Package bottom must be soldered or epoxied to RF/DC ground.

**Part Number Ordering Information**

Part Number	Reel Size	Devices/Reel
SPF-5122Z	7"	3000

**Part Identification**

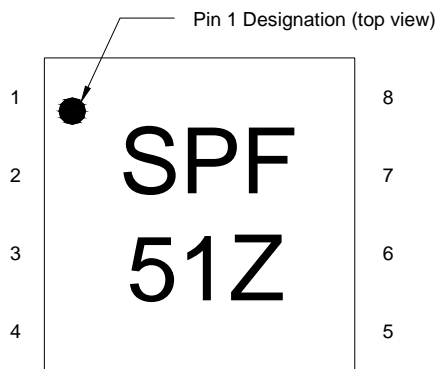

**Suggested Pad Layout**

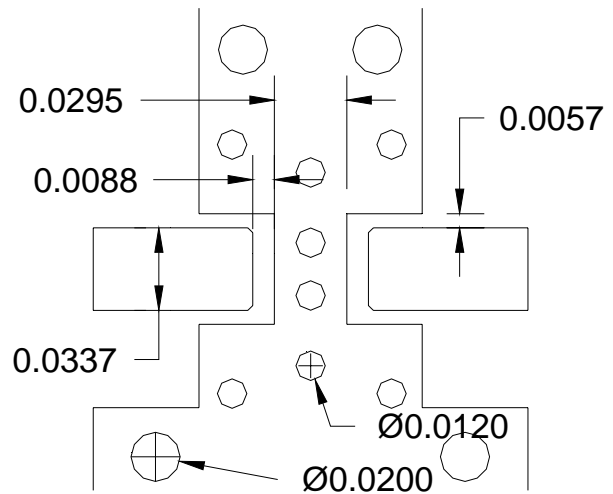

**Nominal Package Dimensions**

Dimensions in inches [millimeters]  
Refer to drawing posted at [www.sirenza.com](http://www.sirenza.com) for tolerances.

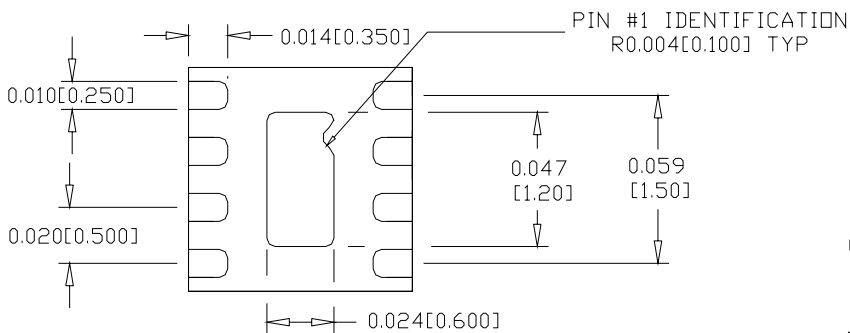

**BOTTOM VIEW**

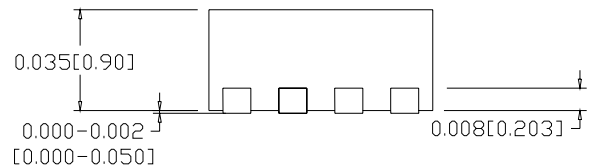

**SIDE VIEW**