

$V_{POS} = -65\text{ V}$, $R_{DS(ON)} = 120\text{ m}\Omega$
4 Series LED Bypass Switches
SPF5047

Description

The SPF5047 is a bypass switch for the high-brightness matrix LEDs used in applications such as automotive headlights. The product includes four series switches to bypass individual LEDs, whose dimming systems are externally controlled by a CPU. Each LED has open and short detections that can send fault flags to the CPU. Even if one of the four LEDs becomes open, the open-LED is bypassed by its built-in power MOSFET so that other LEDs can continue to work normally. The SPF5047 is supplied in a compact, surface-mount type HSOP package, with an exposed pad for enhanced thermal dissipation.

Features

- 4 Series LED Bypass Switches
- Drives Up to 16 LEDs in Series (with 4 ICs; at V_F of an LED is approx. 3 V)
- Low Noise:
No charge-current-induced noise occurs as each gate driver uses a negative power source which requires no charge-pump circuit.
- High Efficiency:
Optimized trade-offs between switching loss and switching noise allow highly-accurate control in tr and tf.
- Fault Flag Reporting
- LED Open Detection
- LED Short Detection

Typical Application

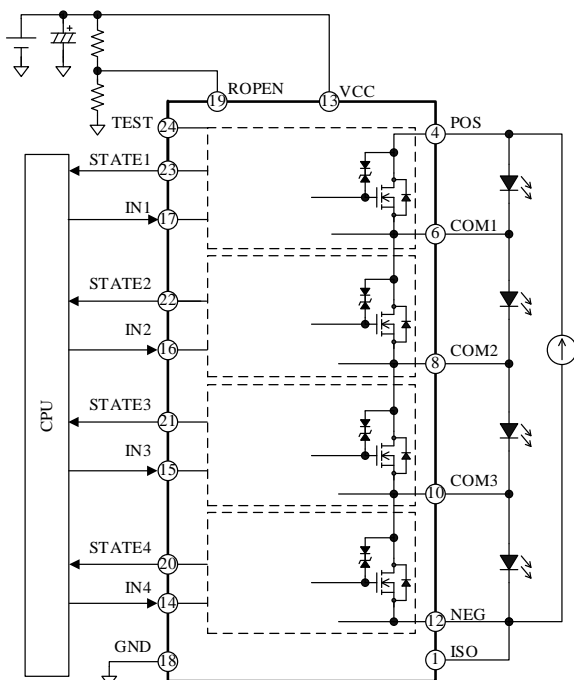

Package

HSOP24

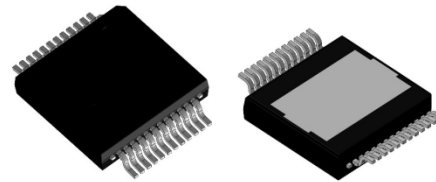

Not to scale

Specifications

- Voltage across LED Capacitors in Series, V_{POS} :
-65 V (max.)
- Bypass Switch Output Current, I_{OUT} : 2 A (max.)
- Bypass Switch On-Resistance (at 25 °C), $R_{DS(ON)}$:
120 mΩ (typ.)

Applications

- Automotive Headlight
- Daylight Running Lamp (DRL)
- High-Brightness Matrix LED System

Contents

Description	1
Contents	2
1. Absolute Maximum Ratings	3
2. Electrostatic Discharge (ESD)	3
3. Recommended Operating Conditions	4
4. Electrical Characteristics	4
5. Block Diagram	6
6. Pin Configuration and Definitions	7
7. Typical Applications	8
8. Physical Dimensions	10
9. Recommended Land Pattern	11
10. Marking Diagram	11
11. Operational Description	12
11.1. Overview	12
11.2. Turning On and Off the IC	12
11.3. Switching Operation	12
11.4. LED Open/Short Detection	12
11.4.1. LED Short Detection	13
11.4.2. LED Open Detection	13
Important Notes	15

1. Absolute Maximum Ratings

Current polarities are defined as follows: current going into the IC (sinking) is positive current (+); and current coming out of the IC (sourcing) is negative current (-).

Unless specifically noted, $T_A = 25\text{ }^\circ\text{C}$, GND = ground.

Parameter	Symbol	Test Conditions	Rating	Unit	Remarks
VCC-NEG Pin Voltage	V_{CN}		70.5	V	
		$t < 10\ \mu\text{s}$	72	V	
NEG Pin Voltage	V_{NEG}		-65 to 0	V	
POS Pin Voltage	V_{POS}		-65 to 0	V	
VCC Pin Voltage	V_{CC}		0 to 5.5	V	
Input Pin Voltage	V_{IN}		0 to 5.5	V	
STATE Pin Voltage	V_{ST}		0 to 5.5	V	
STATE Pin Current	I_{ST}		± 10	mA	
ROPEN Pin Voltage	V_{ROPEN}		0 to 5.5	V	
MOSFET Drain-to-Source Voltage	V_{DS}		V_{CLAMP}^*	V	
MOSFET Active Clamp Time	t_{CLAMP}	1 channel; $I_{OUT} = 2\ \text{A}$	100	ms	
		4 channels at once; $I_{OUT} = 2\ \text{A}$	50	ms	
Output Current	I_{OUT}		2	A	
Junction Temperature	T_j		150	$^\circ\text{C}$	
Operating Ambient Temperature	T_{OPR}		-40 to 125	$^\circ\text{C}$	
Power Dissipation	P_D		6.2	W	
Storage Temperature	T_{stg}		-40 to 150	$^\circ\text{C}$	

* Limited by the active clamp voltage, V_{CLAMP} .

2. Electrostatic Discharge (ESD)

ESD immunity test conditions: $T_A = 25\text{ }^\circ\text{C}$, ISO = ground.

Parameter	Symbol	Conditions	Min.	Typ.	Max.	Unit
Human Body Model (HBM)	$V_{ESD(HBM)}$	$C = 100\ \text{pF}$, $R = 1.5\ \text{k}\Omega^*$	-2000	—	2000	V
Machine Model (MM)	$V_{ESD(MM)}$	$C = 200\ \text{pF}$, $R = 0\ \Omega$; all pins	-200	—	200	V

* Based on JEITA EIAJ ED-4701/304.

3. Recommended Operating Conditions

Parameter	Symbol	Conditions	Min.	Typ.	Max.	Unit	Remarks
Logic Supply Voltage	V_{CC}		4.9	—	5.1	V	VCC pin
PWM Drive Frequency	f_{PWM}		100	—	500	Hz	IN1 to IN4 pins

4. Electrical Characteristics

Current polarities are defined as follows: current going into the IC (sinking) is positive current (+); and current coming out of the IC (sourcing) is negative current (-). Unless specifically noted, the characteristic values listed in this section are values per channel, and GND is the ground. Unless otherwise specified, the conditions are as follows: $T_j = -40\text{ }^{\circ}\text{C}$ to $125\text{ }^{\circ}\text{C}$; ⁽¹⁾ the VCC pin voltage, $V_{CC} = 5.0\text{ V}$; the NEG pin voltage, $V_{NEG} = -30\text{ V}$; with the NEG and ISO pins being shorted. The voltage across the INx pin, which is placed in the channel not to be measured, should be fixed at 5 V.

Parameter	Symbol	Conditions	Min.	Typ.	Max.	Unit
Operation Start Voltage	$V_{CC(ON)}$		3.0	3.5	4.0	V
Operation Stop Voltage	$V_{CC(OFF)}$		2.4	2.7	3.0	V
Circuit Current 1	I_{CC1}	$V_{IN1} = V_{IN2} = V_{IN3} = V_{IN4} = 0\text{ V}$	—	—	11	mA
Circuit Current 2	I_{CC2}	$V_{IN1} = V_{IN2} = V_{IN3} = V_{IN4} = 5\text{ V}$; drain-to-source voltage per MOSFET = 4 V	—	—	11.5	mA
IN Pin Input Threshold Voltage	V_{THH}		3.5	—	—	V
	V_{THL}		—	—	1.5	V
IN Pin Input Current	I_{IN}		—	50	100	μA
Output On-Resistance	$R_{DS(ON)}$	$T_j = 25\text{ }^{\circ}\text{C}$, $I_{OUT} = 1\text{ A}$	—	120	150	m Ω
		$T_j = 125\text{ }^{\circ}\text{C}$, $I_{OUT} = 1\text{ A}$	—	—	250	m Ω
Active Clamp Voltage	V_{CLAMP}	$I_{OUT} = 1\text{ A}$; INx in the non-measuring channel = 0 V fixed	12	15	18	V
Short Detection Voltage ⁽²⁾	V_{SH}	$V_{ROPEN} = 2\text{ V}$	1.25	1.5	1.75	V
Setting Range for Open Detection Threshold Voltage ⁽²⁾	V_{OPR}		1.75	—	11	V
Open Detection Voltage ⁽²⁾	V_{OP2}	$V_{ROPEN} = 0.5\text{ V}$	1.84	2.00	2.16	V
	V_{OP4}	$V_{ROPEN} = 1\text{ V}$	3.68	4.00	4.32	V
	V_{OP8}	$V_{ROPEN} = 2\text{ V}$	7.36	8.00	8.64	V
	V_{OP10}	$V_{ROPEN} = 2.5\text{ V}$	9.2	10.0	10.8	V
ROPEN Pin Input Current	I_{ROP}	$V_{ROPEN} = 3\text{ V}$	—	1.2	4	μA
STATE Pin Output Voltage	V_{STH}	$I_{STATE} = -5\text{ mA}$	$V_{CC} - 0.5$	—	V_{CC}	V
	V_{STL}	$I_{STATE} = 5\text{ mA}$	0	—	0.5	V
Minimum Open/Short Detection Time	t_{DET}		50	—	—	μs

⁽¹⁾ " $T_j = -40\text{ }^{\circ}\text{C}$ " is the parameter ensured by design only. For shipping inspection, all electrical characteristics values should be evaluated at $T_j = 25\text{ }^{\circ}\text{C}$ or $125\text{ }^{\circ}\text{C}$.

⁽²⁾ Refers to drain-to-source voltage across each built-in MOSFET.

SPF5047

Parameter	Symbol	Conditions	Min.	Typ.	Max.	Unit
Internal Oscillator Clock Cycle	t_{CLK}		3.04	4	4.96	μs
Short Detection Filter Time	t_{SH}	$V_{ROPEN} = 2 V$	17.1	22.5	27.9	ms
Open Detection Filter Time	t_{OP}	$V_{ROPEN} = 2 V$	17.1	22.5	27.9	ms
Short Detection Recovery Delay Time	t_{SHB}	$V_{ROPEN} = 2 V$	—	—	50	μs
Open Detection Delay Time	t_{OPR}	$V_{ROPEN} = 2 V$	—	—	50	μs
Open Recovery Filter Time	t_{OPB}	$V_{ROPEN} = 2 V$	12.4	16.4	20.4	ms
Filter Time Difference	t_{OP-OPB}	$t_{OP-OPB} = t_{OP} - t_{OPB}$	4.7	6.1	7.5	ms
Output Propagation Delay	t_{ON}	(3)	—	40	80	μs
	t_{OFF}		—	40	80	μs
Output Rise Time	t_r		30	70	110	μs
Output Fall Time	t_f		30	70	110	μs
Output Propagation Delay Difference	t_{DIFF}		-30	—	30	μs
Junction-to-Case Thermal Resistance	θ_{jC}			—	—	4.9

(3) Drain-to-source voltage per MOSFET = -30 V, with a 4 Ω source resistor being connected. Short the NEG pin to the source pin in the channel to be measured. For switching characteristics definitions, see Figure 4-1 below.

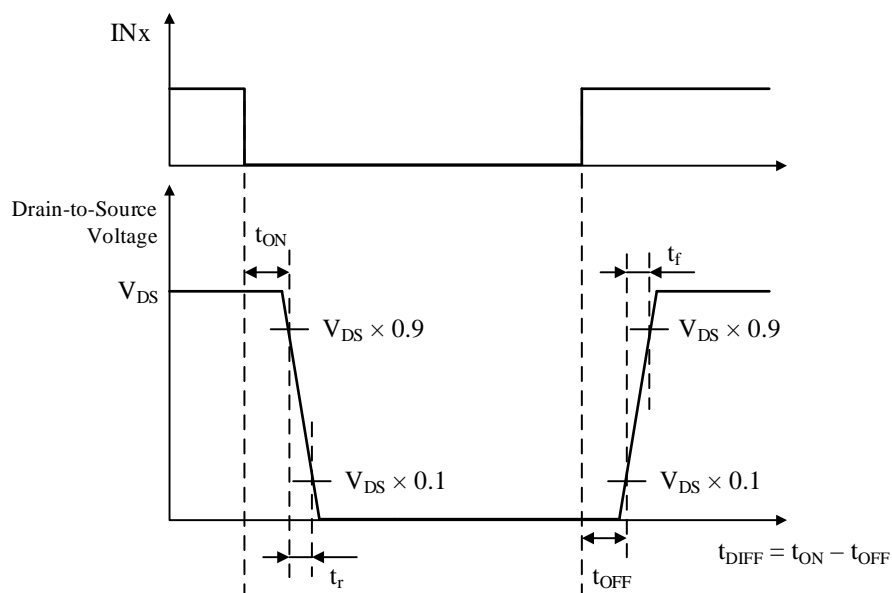
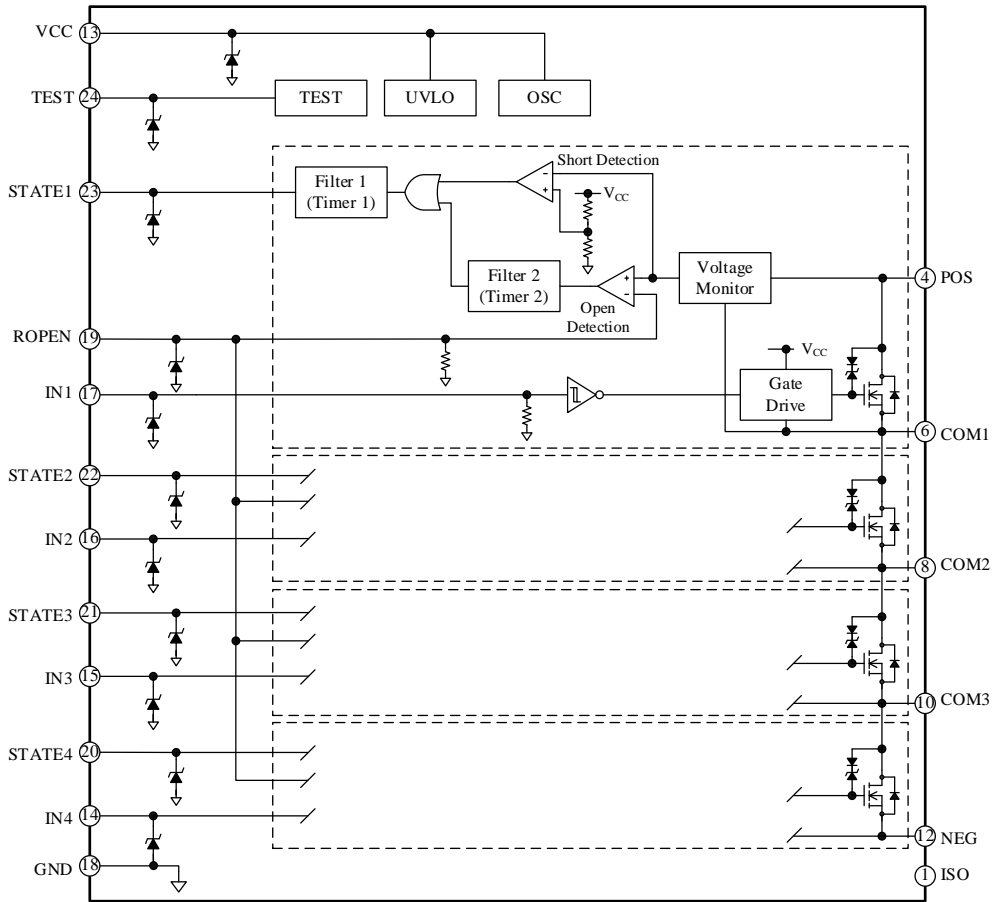
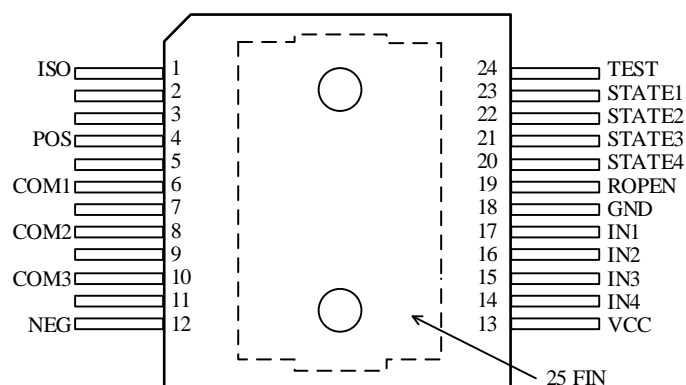

Figure 4-1. Switching Characteristics Definitions

5. Block Diagram



6. Pin Configuration and Definitions



Pin Number	Pin Name	Function
1	ISO	MIC reference; internally shorted to NEG
2	N.C.	No connection
3	N.C.	No connection
4	POS	Drain of Channel 1
5	N.C.	No connection
6	COM1	Source of Channel 1, drain of Channel 2
7	N.C.	No connection
8	COM2	Source of Channel 2, drain of Channel 3
9	N.C.	No connection
10	COM3	Source of Channel 3, drain of Channel 4
11	N.C.	No connection
12	NEG	Source of Channel 4; internally shorted to ISO
13	VCC	5 V power supply
14	IN4	Input for Channel 4
15	IN3	Input for Channel 3
16	IN2	Input for Channel 2
17	IN1	Input for Channel 1
18	GND	Ground
19	ROPEN	Threshold voltage setting for LED open detection; commonly applied to all channels (1 to 4)
20	STATE4	Open/short detection for Channel 4
21	STATE3	Open/short detection for Channel 3
22	STATE2	Open/short detection for Channel 2
23	STATE1	Open/short detection for Channel 1
24	TEST	Product inspection; normally left unused; must be shorted to GND when used
25	FIN	Backside heatsink; must be shorted to NEG and ISO when used

7. Typical Applications

The NEG pin, the ISO pin, and the backside heatsink must be shorted on a PCB. Connect these pins to the lowest potential (negative potential) among other pins.

The TEST pin must be shorted to the GND pin on a PCB.

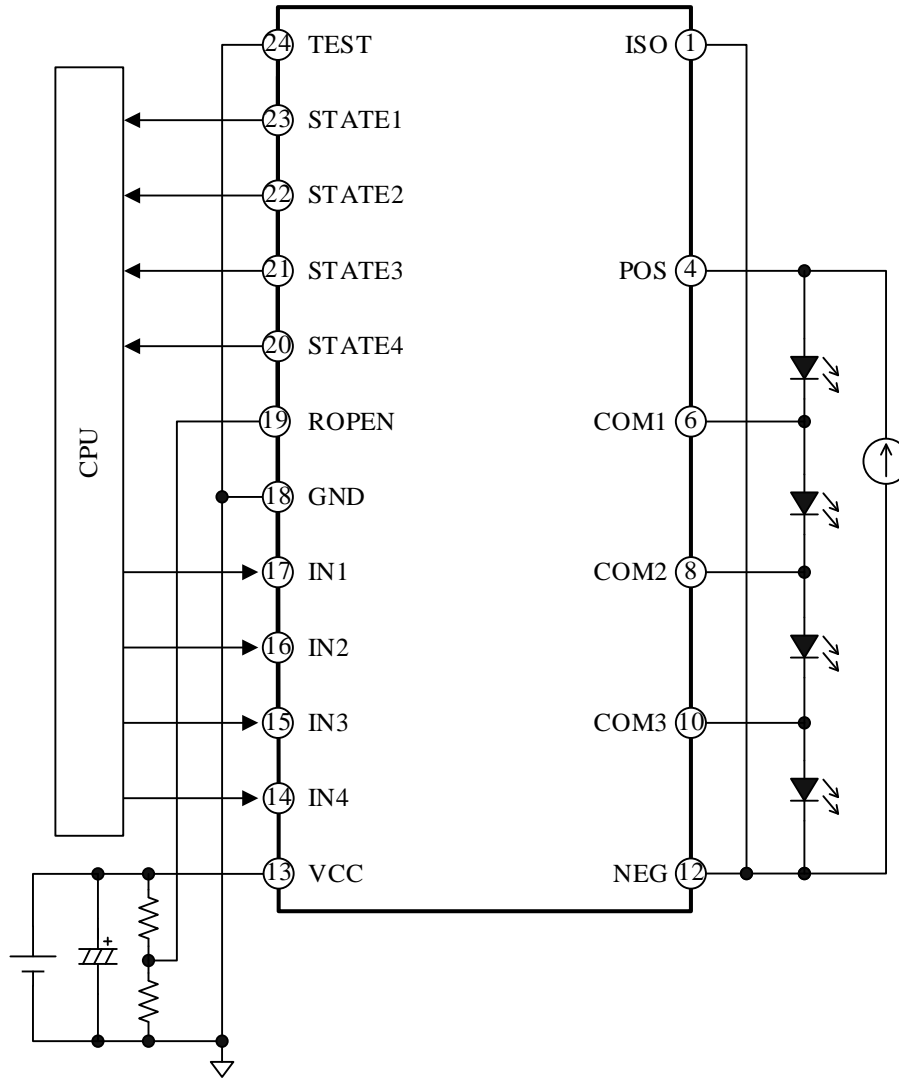

Figure 7-1. Typical Application (4 channels)

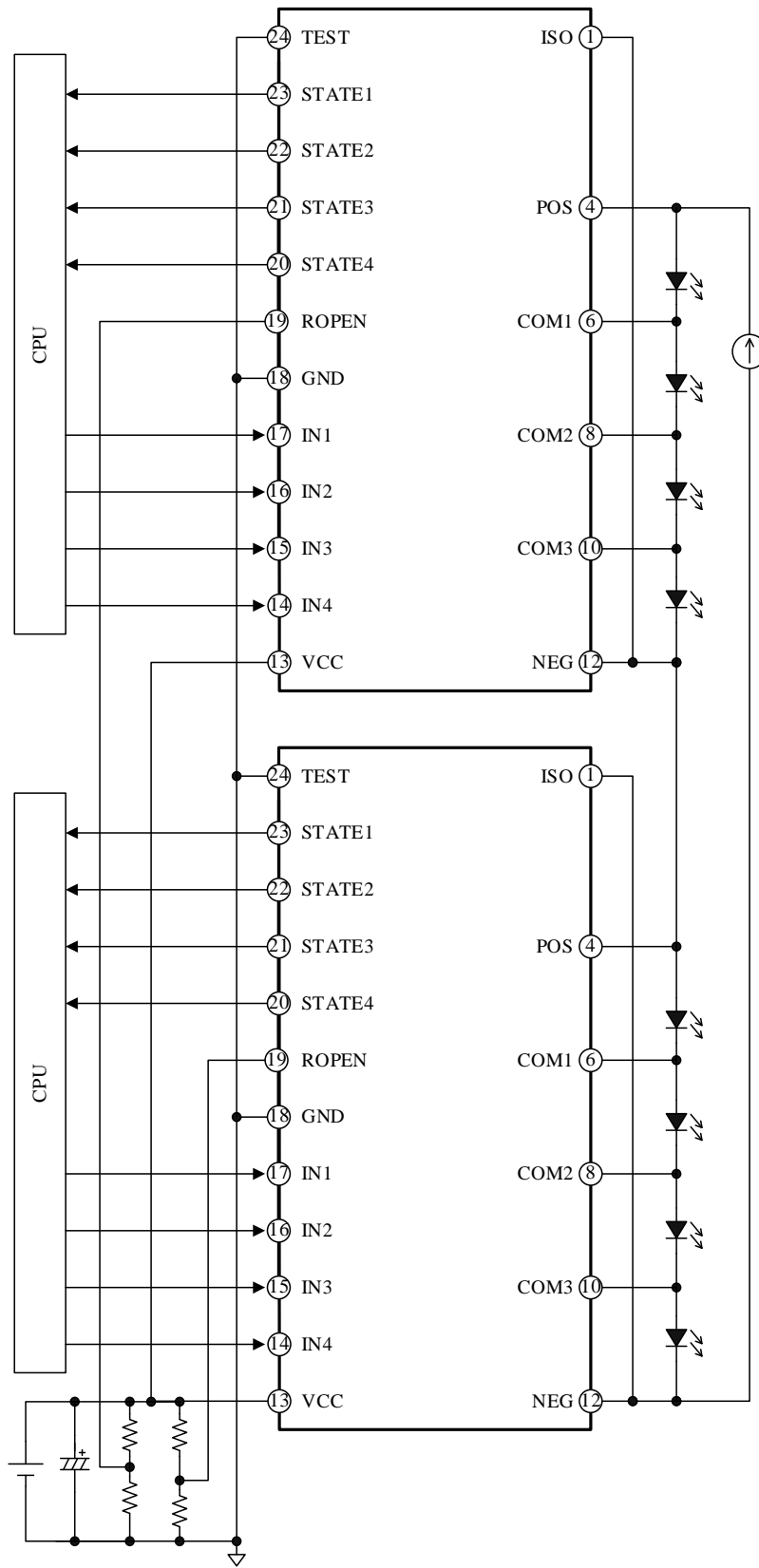
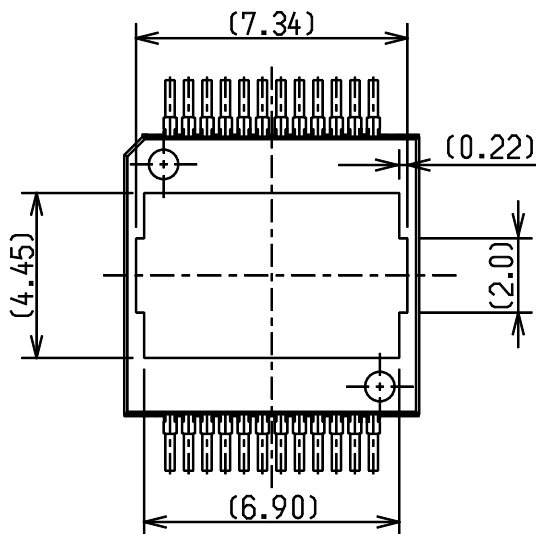
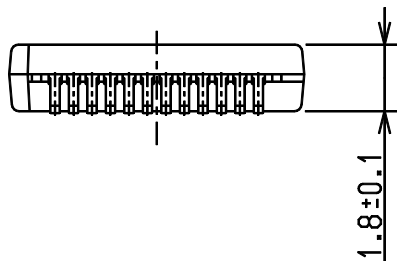
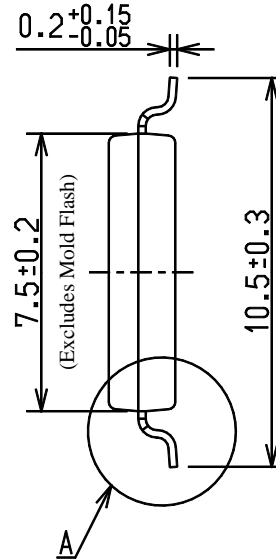
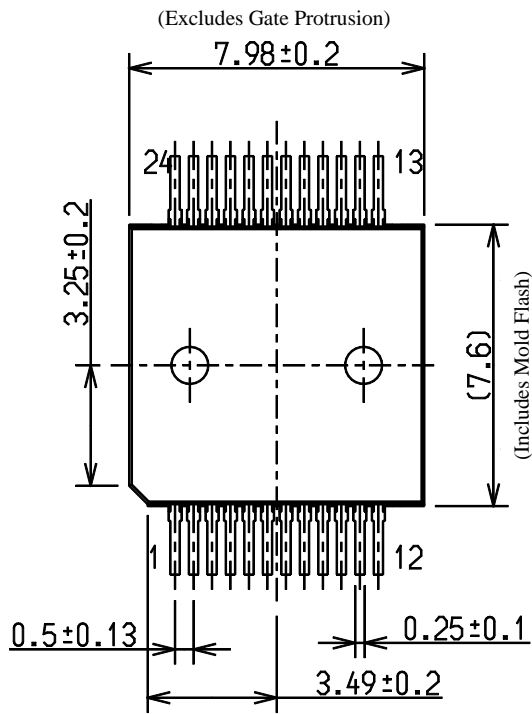

Figure 7-2. Typical Application (8 channels)

8. Physical Dimensions

- HSOP24



Enlarged View of A

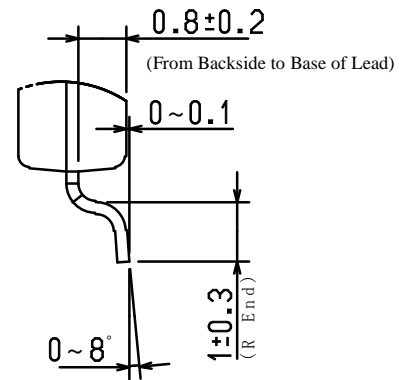

NOTES:

- Dimensions in millimeters
- Pin treatment: Pb-free (RoHS compliant)
- Reflow

9. Recommended Land Pattern

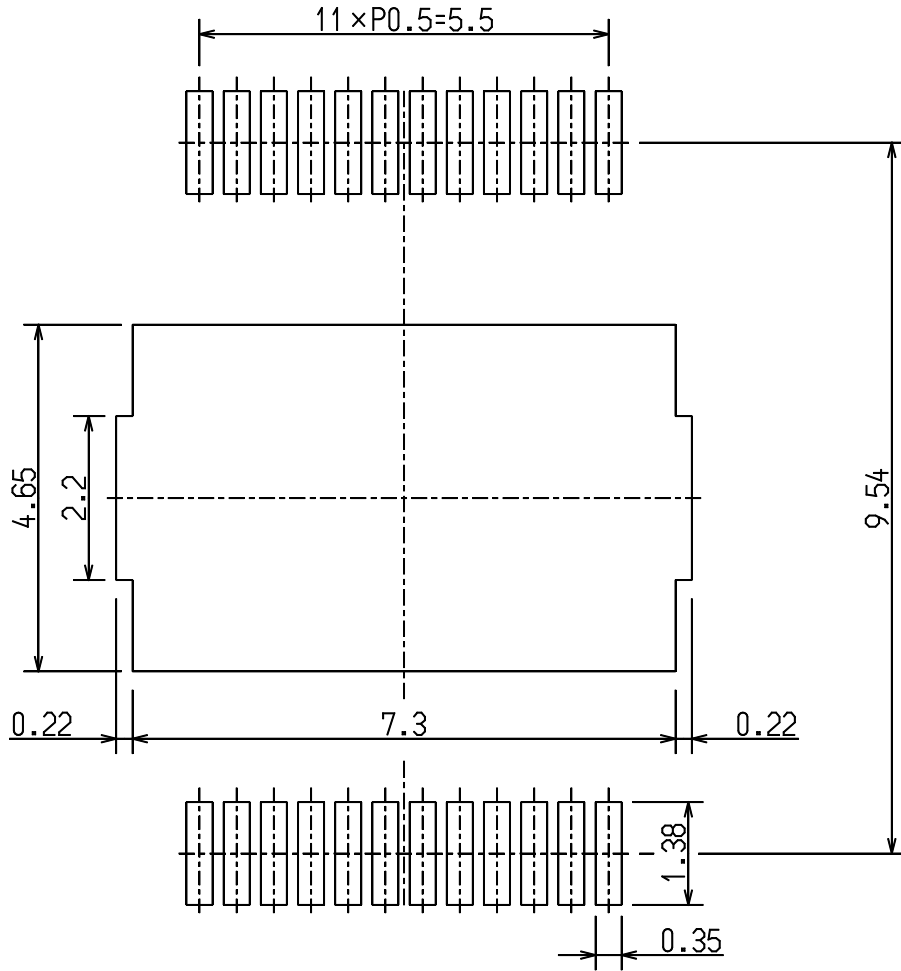

10. Marking Diagram

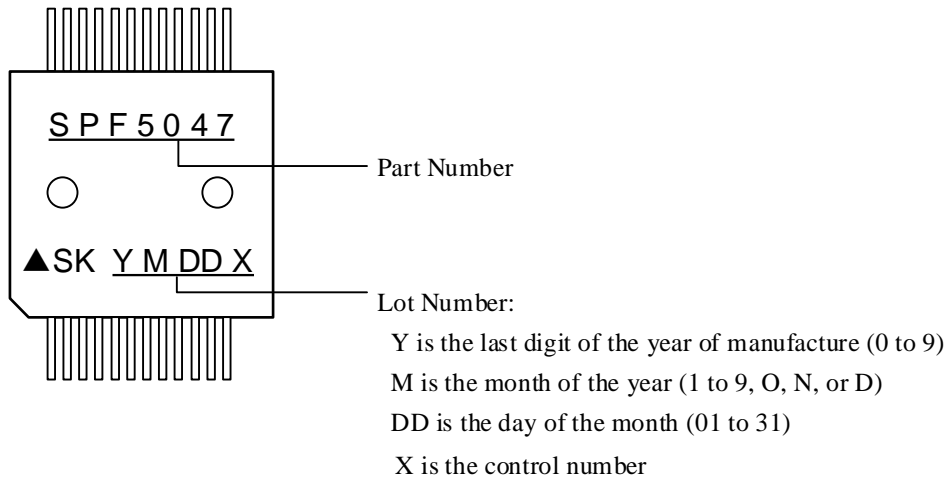

11. Operational Description

The characteristic values listed in this section are typical values, unless they are specified as minimum or maximum. Current polarities are defined as follows: current going into the IC (sinking) is positive current (+); and current coming out of the IC (sourcing) is negative current (-).

11.1. Overview

The SPF5047 is designed to provide dynamic dimming control for each of the four LEDs connected in series. The built-in MOSFETs connected in parallel to the LEDs alter the currents through these LEDs individually. With this array strategy, the LEDs used in the SPF5047 can be quickly turned off and be partially dimmed even they are series-connected.

Moreover, each LED has open and short detections that can emit fault flags.

11.2. Turning On and Off the IC

The IC includes the UVLO (Undervoltage Lockout) circuit. When $V_{CC(ON)} \geq 3.5$ V, the control circuit in the IC is activated.

The IC then drives the LEDs and sends PWM signals to all the INx pins (IN1 to IN4).

When $V_{CC(OFF)} \leq 2.7$ V, the UVLO circuit starts its operation to deactivate the control circuit.

11.3. Switching Operation

A driving signal on the INx pin actuates the corresponding output MOSFET. (“INx” represents any one of the outputs.) The output MOSFET then starts operating synchronously with the input signal on the INx pin. In a state where the INx pin is logic low (or “L”) and the MOSFET is on, an individual LED turns off. The INx pin is also used to control LED brightness. A PWM signal on the INx pin can enable PWM dimming, which changes the light intensity of an LED with a predetermined duty cycle. The frequency of PWM signals should range from 100 Hz to 500 Hz.

The IC allows highly-accurate control in switching characteristics, t_r and t_f , through optimized trade-offs between switching loss and switching noise. Consequently, the IC achieves high-efficient, low-noise switching operations.

The control circuit is driven by a positive power source, whereas the MOSFET driver is actuated by a negative power source in which the voltage between the POS and NEG pins is lower than the ground potential. In this method, the MOSFET driver does not need any charge-pump circuit; therefore, charge-current-induced noise can be suppressed.

11.4. LED Open/Short Detection

Figure 11-1 shows the internal block diagram of Channel 1 (CH1).

The IC monitors the output MOSFET drain-to-source voltage, V_{DS} , to determine if an LED open or short event has occurred.

First, V_{DS} is measured and then multiplied by 0.25, with an internal voltage monitor. Then, the 0.25 times voltage value is input to open and short detection comparators, respectively. Each of the open and short detection comparators has a filter with the minimum open/short detection time, t_{DET} , of 50 μ s (min.). Therefore, a signal shorter than t_{DET} cannot be detected as a fault flag.

Figure 11-2 describes the relationship between input voltage across the open/short detection comparator and drain-to-source voltage.

When the IC detects any malfunction, the STATEx pin is set to logic high (or “H”) and transmits a fault flag to the microcontroller. (“STATEx” represents any one of the outputs.) The IC incorporates filters to remove noise signals so that the microcontroller can properly respond to a low-to-high transition on the STATEx pin input signal. A clock cycle generated by the built-in oscillator (OSC) determines a filter time.

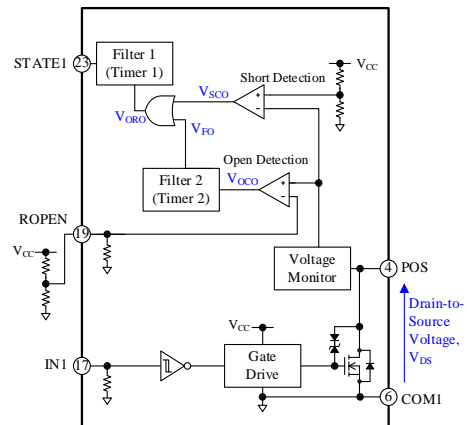

Figure 11-1. Internal Block Diagram (CH1)

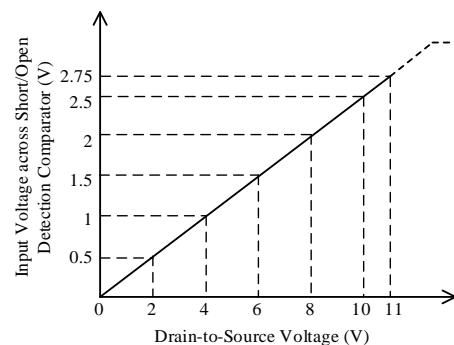

Figure 11-2. Input Voltage across Open/Short Detection Comparator vs. Drain-to-Source Voltage

11.4.1. LED Short Detection

Figure 11-3 shows the operating waveforms during an LED short event. And Figure 11-4 provides the enlarged view of A, illustrated in Figure 11-3.

If one or more LEDs are shorted to ground, the MOSFET drain-to-source voltage, V_{DS} , attempts to decrease.

The short detection voltage, V_{SH} , is used for LED status diagnostics and is set to 1.5 V. When a short condition (where $V_{DS} \leq V_{SH}$) persists for a period greater than the short detection filter time (t_{SH}) of 22.5 ms, the STATEx pin in the shorted-LED channel becomes logic high (or “H”).

When V_{DS} exceeds V_{SH} under the short condition, the short detection comparator waits to invert its output until t_{SHB} , the open detection recovery time of 50 μ s (max.), has elapsed. Following the output inversion of the short detection comparator, the STATEx pin is put into a logic low state (or “L”) after 12 cycles of a clock pulse. Then, the IC resumes its normal operation.

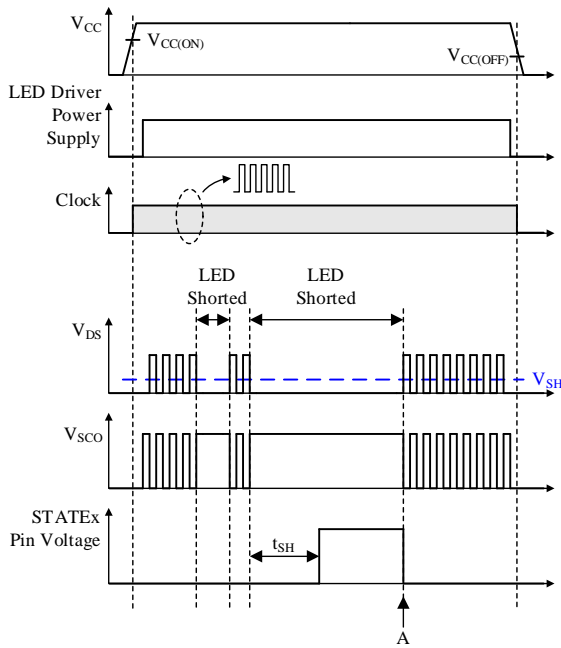

Figure 11-3. Waveforms during Short Detection

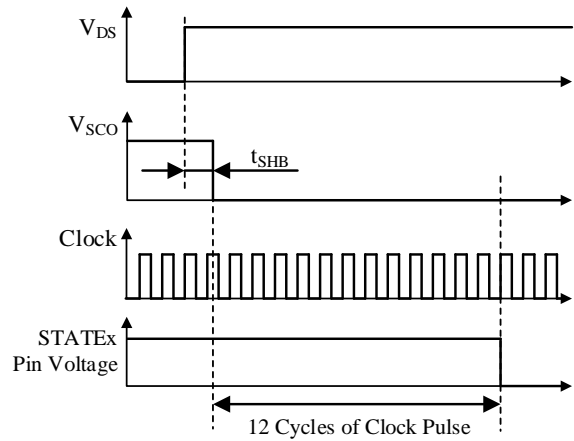

Figure 11-4. Waveforms during Short Detection (Enlarged View of A)

11.4.2. LED Open Detection

Figure 11-5 shows the operating waveforms during an LED open event. And Figure 11-6 provides the enlarged view of B, illustrated in Figure 11-5.

If one or more LEDs are open, the MOSFET drain-to-source voltage, V_{DS} , attempts to increase.

The open detection voltage, V_{OP} , is used to detect open-LEDs. When an open condition (where $V_{DS} \geq V_{OP}$) persists for a period greater than the open detection filter time (t_{OP}) of 22.5 ms, the STATEx pin in the open-LED channel becomes logic high (or “H”).

Even after the open detection comparator output, V_{OCO} , is held logic high, the microcontroller does not respond to an “H” signal whose duration is shorter than 3 cycles of a clock pulse (see Figure 11-5). This is to prevent false detections. When V_{DS} falls below V_{OP} , the voltage on the open detection comparator, V_{OCO} , will be inverted after t_{OPB} , the open recovery filter time of 16.4 ms. Following the output inversion of the open detection comparator, the short detection comparator is inverted after t_{SHB} of 50 μ s (max.). Then, the STATEx pin is put into a logic low state (or “L”) after 12 cycles of a clock pulse. This high-to-low transition mechanism is identical to that of the LED short detection, as shown in Figure 11-4. Then, the IC resumes its normal operation.

Table 11-1 indicates how the V_{OP} values vary according to the ROPEN pin voltages. Hence, note that the ROPEN pin voltages must be determined according to LED currents.

Table 11-1. Open Detection Voltage vs. ROPEN Pin Voltage

Symbol	ROPEN Pin Voltage	Open Detection Voltage, V_{OP}		
		Min.	Typ.	Max.
V_{OP2}	0.5 V	1.84 V	2.00 V	2.16 V
V_{OP4}	1 V	3.68 V	4.00 V	4.32 V
V_{OP8}	2 V	7.36 V	8.00 V	8.64 V
V_{OP10}	2.5 V	9.2 V	10.0 V	10.8 V

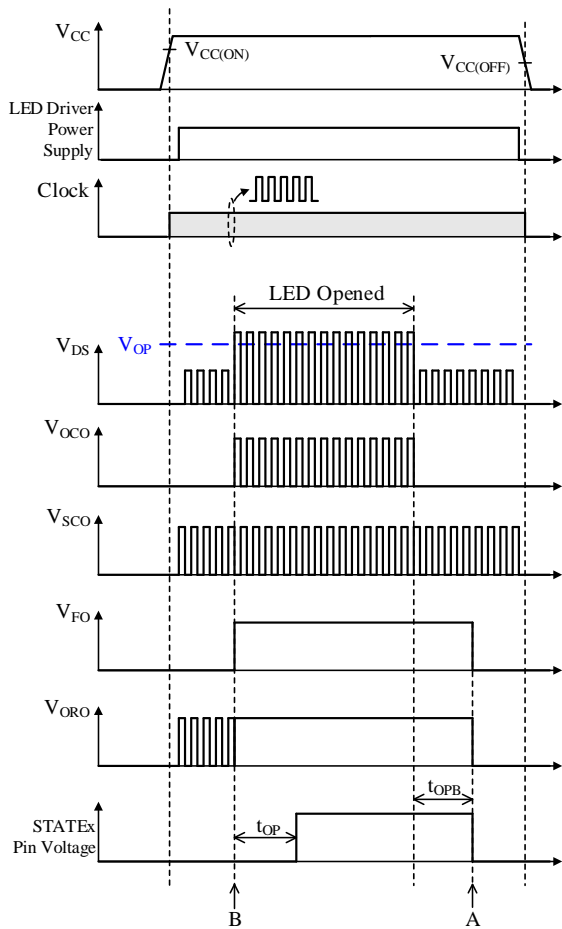

Figure 11-5. Waveforms during Open Detection

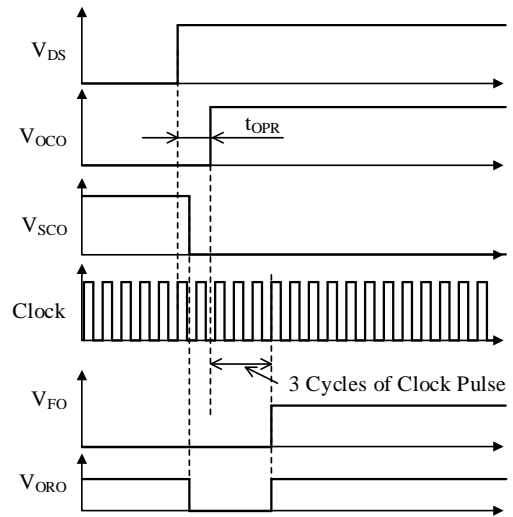

Figure 11-6. Waveforms during Open Detection (Enlarged View of B)

Important Notes

- All data, illustrations, graphs, tables and any other information included in this document as to Sanken's products listed herein (the "Sanken Products") are current as of the date this document is issued. All contents in this document are subject to any change without notice due to improvement of the Sanken Products, etc. Please make sure to confirm with a Sanken sales representative that the contents set forth in this document reflect the latest revisions before use.
- The Sanken Products are intended for use as components of electronic equipment or apparatus (transportation equipment and its control systems, home appliances, office equipment, telecommunication equipment, measuring equipment, etc.). Prior to use of the Sanken Products, please put your signature, or affix your name and seal, on the specification documents of the Sanken Products and return them to Sanken. If considering use of the Sanken Products for any applications that require higher reliability (traffic signal control systems or equipment, disaster/crime alarm systems, etc.), you must contact a Sanken sales representative to discuss the suitability of such use and put your signature, or affix your name and seal, on the specification documents of the Sanken Products and return them to Sanken, prior to the use of the Sanken Products. The Sanken Products are not intended for use in any applications that require extremely high reliability such as: aerospace equipment; nuclear power control systems; and medical equipment or systems, whose failure or malfunction may result in death or serious injury to people, i.e., medical devices in Class III or a higher class as defined by relevant laws of Japan (collectively, the "Specific Applications"). Sanken assumes no liability or responsibility whatsoever for any and all damages and losses that may be suffered by you, users or any third party, resulting from the use of the Sanken Products in the Specific Applications or in manner not in compliance with the instructions set forth herein.
- In the event of using the Sanken Products by either (i) combining other products or materials therewith or (ii) physically, chemically or otherwise processing or treating the same, you must duly consider all possible risks that may result from all such uses in advance and proceed therewith at your own responsibility.
- Although Sanken is making efforts to enhance the quality and reliability of its products, it is impossible to completely avoid the occurrence of any failure or defect in semiconductor products at a certain rate. You must take, at your own responsibility, preventative measures including using a sufficient safety design and confirming safety of any equipment or systems in/for which the Sanken Products are used, upon due consideration of a failure occurrence rate or derating, etc., in order not to cause any human injury or death, fire accident or social harm which may result from any failure or malfunction of the Sanken Products. Please refer to the relevant specification documents and Sanken's official website in relation to derating.
- No anti-radioactive ray design has been adopted for the Sanken Products.
- No contents in this document can be transcribed or copied without Sanken's prior written consent.
- The circuit constant, operation examples, circuit examples, pattern layout examples, design examples, recommended examples, all information and evaluation results based thereon, etc., described in this document are presented for the sole purpose of reference of use of the Sanken Products and Sanken assumes no responsibility whatsoever for any and all damages and losses that may be suffered by you, users or any third party, or any possible infringement of any and all property rights including intellectual property rights and any other rights of you, users or any third party, resulting from the foregoing.
- All technical information described in this document (the "Technical Information") is presented for the sole purpose of reference of use of the Sanken Products and no license, express, implied or otherwise, is granted hereby under any intellectual property rights or any other rights of Sanken.
- Unless otherwise agreed in writing between Sanken and you, Sanken makes no warranty of any kind, whether express or implied, including, without limitation, any warranty (i) as to the quality or performance of the Sanken Products (such as implied warranty of merchantability, or implied warranty of fitness for a particular purpose or special environment), (ii) that any Sanken Product is delivered free of claims of third parties by way of infringement or the like, (iii) that may arise from course of performance, course of dealing or usage of trade, and (iv) as to any information contained in this document (including its accuracy, usefulness, or reliability).
- In the event of using the Sanken Products, you must use the same after carefully examining all applicable environmental laws and regulations that regulate the inclusion or use of any particular controlled substances, including, but not limited to, the EU RoHS Directive, so as to be in strict compliance with such applicable laws and regulations.
- You must not use the Sanken Products or the Technical Information for the purpose of any military applications or use, including but not limited to the development of weapons of mass destruction. In the event of exporting the Sanken Products or the Technical Information, or providing them for non-residents, you must comply with all applicable export control laws and regulations in each country including the U.S. Export Administration Regulations (EAR) and the Foreign Exchange and Foreign Trade Act of Japan, and follow the procedures required by such applicable laws and regulations.
- Sanken assumes no responsibility for any troubles, which may occur during the transportation of the Sanken Products including the falling thereof, out of Sanken's distribution network.
- Although Sanken has prepared this document with its due care to pursue the accuracy thereof, Sanken does not warrant that it is error free and Sanken assumes no liability whatsoever for any and all damages and losses which may be suffered by you resulting from any possible errors or omissions in connection with the contents included herein.
- Please refer to the relevant specification documents in relation to particular precautions when using the Sanken Products, and refer to our official website in relation to general instructions and directions for using the Sanken Products.
- All rights and title in and to any specific trademark or tradename belong to Sanken or such original right holder(s).

DSGN-AEZ-16002