

SELECTABLE-OUTPUT CRYSTAL OSCILLATOR

SPG series

- Capable of selecting 57 varieties of frequency output.
- Low current consumption.
- Easy to mount DIP 16-pin package.

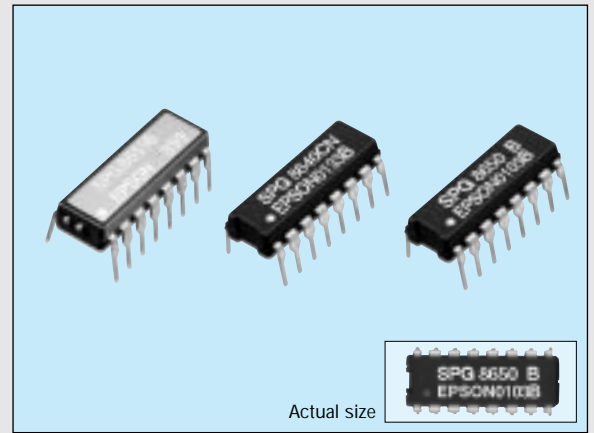

Specifications (characteristics)

Item	Symbol	Specifications										Remarks	
Model name		8640AN	8640BN	8640CN	8650A	8650B	8650C	8650E	8651A	8651B	8651E		
Oscillation source frequency	f_o	600kHz	1MHz	768kHz	60kHz	100kHz	96kHz	32.768kHz	60kHz	100kHz	32.768kHz	For output frequency, refer to the table in the next page	
Power source voltage	Max. supply voltage	V_{DD-GND}										-0.3V to +7.0V	
	Operating voltage	V_{DD}										5.0V±0.5V	
Temperature range	Storage temperature	T_{STG}										-55°C to +125°C	-30°C to +80°C
	Operating temperature	T_{OPR}										-10°C to +70°C	-10°C to +60°C
Soldering condition (lead part)	T_{SOL}	Under 260°C within 10 sec.										Package should be less than 150°C	
Frequency tolerance	$\Delta f/f_o$	±100ppm			±50ppm			±5ppm *1			$V_{DD}=5V, T_a=25^\circ C$		
Frequency temperature characteristics		+10/-120ppm										$V_{DD}=5V$	
Frequency voltage characteristics		±20ppm	±10ppm	±20ppm	±10ppm			±5ppm			$V_{DD}=4.5$ to 5.5V		
Aging	f_a	±5ppm/year max.										±3ppm/year max.	$V_{DD}=5V, T_a=25^\circ C$, first year
Current consumption	I_{OP}	1.0mA max.	2.0mA max.	1.5mA max.	0.5mA max.						No load condition		
Shock resistance	S.R.	±5ppm max.			±5ppm max.			±10ppm max.			Three drops on a hard wooden board form 75cm		

*1 Frequency tolerance of 8651 system shows the value guaranteed at the time of shipment.

Electric characteristics ($V_{DD}=5V\pm 0.5V, T_a=-10$ to $+70^\circ C, C_L \leq 15pF$)

Item	Symbol	Min.	Typ.	Max.	Unit	Remarks
L. input voltage	V_{IL}	0		0.8	V	
H. input voltage	V_{IH}	$V_{DD}-1.0$		V_{DD}	V	
L. input current (Reset)	I_{RL}	-30		-5	μA	Reset=GND
H input current (Reset)	I_{RH}			0.5	μA	Reset= V_{DD}
L. input current (input terminal except for Reset)	I_{iL}	-0.5			μA	
H input current (input terminal except for Reset)	I_{iH}	5		30	μA	$I_{OL}=1.6mA$
L. output voltage	V_{OL}			0.4	V	$I_{OH}=-40\mu A$
H. output voltage	V_{OH}	$V_{DD}-1.0$			V	$V_{OL}=0.4V$
L. output current	I_{OL}	1.6			mA	$V_{OH}=V_{DD}-1.0V$
H. output current	I_{OH}			-40	μA	
Output rise time	t_{TLH}		30	60	ns	
Output fall time	t_{THL}		25	50	ns	
Duty		40		60	%	Except in the case of 1/3 and 1/5
Min. reset pulse width	t_{rw}	1.0			μs	
Reset delay time	t_r			1.0	μs	
Reset release synchronous error	t_e	$t_w \times \frac{1}{1/2}$ to		$t_w \times 2$	μs	
External signal input frequency	F_{IN}			1M	Hz	8640N only
External signal input pulse width	t_{IN}	0.5			μs	
Oscillation start up time	t_{OSC}		0.2	1	s	* 3

* 1 t_o -to-oscillation source cycle. * 2 $t_w=1/2$ cycle of preset frequency. * 3 For more than 1ms until $V_{DD}=0 \rightarrow 4.5V$. Time at 4.5V is to be 0.

Block diagram

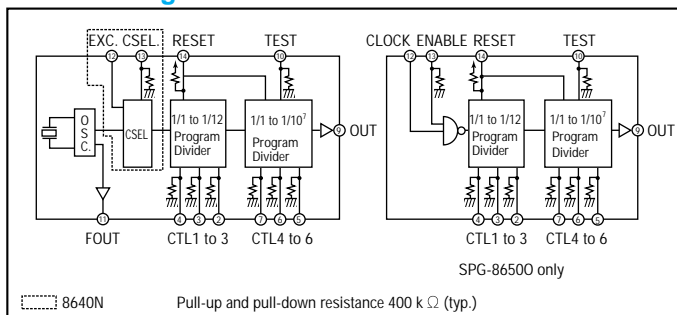

Divider IC (without quartz crystal)

Item	Symbol	Specifications	Remarks
Model name		8650 O	
Input clock frequency		1 MHz max.	
Current consumption	I_{OP}	About 2 mA	No load condition

RESET timing

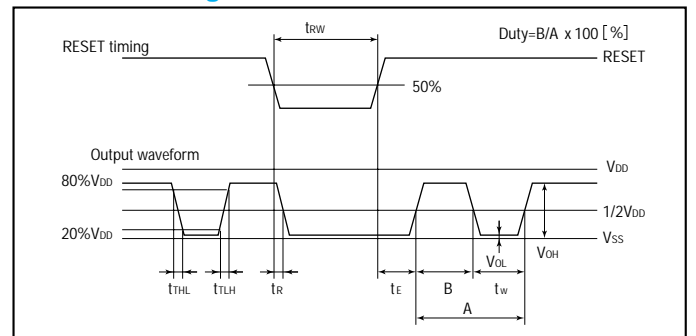

External dimensions

(Unit: mm)

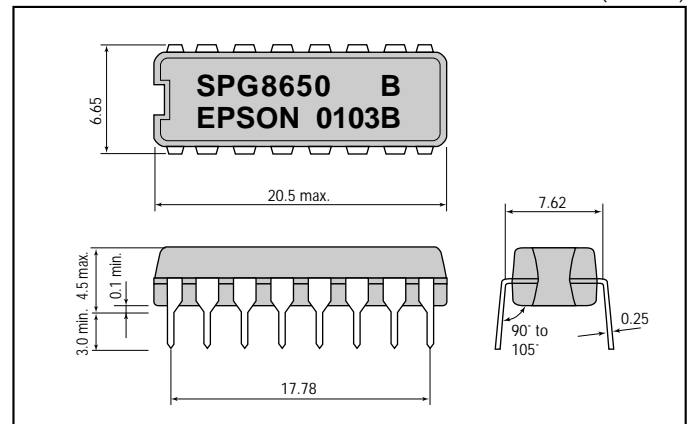

Terminal connection

No.	Pin terminal	No.	Pin terminal
1	NC	16	V _{DD}
2	CTL 3	15	NC
3	CTL 2	14	RESET
4	CTL 1	13	NC (CSEL)
5	CTL 6	12	NC (EXC)
6	CTL 5	11	FOUT
7	CTL 4	10	TEST
8	GND	9	OUT

() shown 8640N only
 For 8650 O
 NC: Do not connect to the external terminal. 11. NC 12. CLOCK 13. ENABLE

Explanation of terminal

- (a) CTL 1 to 6 : Programs dividing ratio. (pull-down resistor incorporated.)
- (b) OUT : Output frequency preset by CTL1 to 6. (refer to the procedure for setting output frequency.)
- (c) FOUT : Constantly outputs the oscillation source frequency of builtin crystal unit.
- (d) RESET : Stops output at RESET= "L". (pull-up resistor incorporated.)
- (e) TEST : Used for the input terminal for testing. When CTL4 is H, output will be 1000 times larger than the preset value at TEST= "H". (pull-down resistor incorporated.)
- (f) EXC (8640N only) : Serves as input terminal when using an external clock by changing to the builtin oscillator. Effective only when CSEL is H.
- (g) CSEL (8640N only) : When this terminal is made H, the external clock is selected. (pull-down resistor incorporated.)

(Note) Treatment of empty terminals. When RESET terminal is not used, this should be connected to V_{DD}, and when TEST terminal, CSEL terminal, and CTL 1 to 6 terminals are not used, to GND.

Explanation of terminal (8650 O)

- (a) CLOCK: Clock input (max. 1 MHz) (b) ENABLE: Be sure to connect to V_{DD}

Setting of divider output

CTL1	CTL2	CTL3	Dividing ratio	CTL4	CTL5	CTL6	Dividing ratio
0	0	0	1/1	0	0	0	1/1
0	0	1	1/10	0	0	1	1/10
0	1	0	1/2	0	1	0	1/10 ²
0	1	1	1/3	0	1	1	1/10 ³
1	0	0	1/4	1	0	0	1/10 ⁴
1	0	1	1/5	1	0	1	1/10 ⁵
1	1	0	1/6	1	1	0	1/10 ⁶
1	1	1	1/12	1	1	1	1/10 ⁷

0= "L" 1="H"

Setting of output frequency

8640AN

(Unit: Hz)

Set terminal	CTL4	CTL5	CTL6	CTL3	CTL2	CTL1	Output frequency	Baud rate output example (to/16)
0	0	0	0	0	0	0	600k	48000bits/sec.
0	0	1	0	0	0	0	60k	9600
0	1	0	0	0	0	0	300k	600
0	1	1	0	0	0	0	200k	400
1	0	0	0	0	0	0	150k	300
1	0	1	0	0	0	0	120k	240
1	1	0	0	0	0	0	100k	200
1	1	1	0	0	0	0	50k	100

8640BN

Set terminal	CTL4	CTL5	CTL6	CTL3	CTL2	CTL1	Output frequency	Baud rate output example (to/16)
0	0	0	0	0	0	0	1M	60000bits/sec.
0	0	1	0	0	0	0	100k	1200
0	1	0	0	0	0	0	500k	600
0	1	1	0	0	0	0	333.3k	300
1	0	0	0	0	0	0	250k	200
1	0	1	0	0	0	0	200k	150
1	1	0	0	0	0	0	166.6k	100
1	1	1	0	0	0	0	83.3k	50

8650A 8651A

Set terminal	CTL4	CTL5	CTL6	CTL3	CTL2	CTL1	Output frequency	Baud rate output example (to/16)
0	0	0	0	0	0	0	60k	48000bits/sec.
0	0	1	0	0	0	0	6k	9600
0	1	0	0	0	0	0	30k	600
0	1	1	0	0	0	0	20k	400
1	0	0	0	0	0	0	15k	300
1	0	1	0	0	0	0	12k	240
1	1	0	0	0	0	0	10k	200
1	1	1	0	0	0	0	5k	100

8650B 8651B

Set terminal	CTL4	CTL5	CTL6	CTL3	CTL2	CTL1	Output frequency	Baud rate output example (to/16)
0	0	0	0	0	0	0	100k	60000bits/sec.
0	0	1	0	0	0	0	10k	12000
0	1	0	0	0	0	0	50k	6000
0	1	1	0	0	0	0	33.3k	4000
1	0	0	0	0	0	0	25k	3000
1	0	1	0	0	0	0	20k	2400
1	1	0	0	0	0	0	16.6k	2000
1	1	1	0	0	0	0	8.3k	1000

8650E 8651E

Set terminal	CTL4	CTL5	CTL6	CTL3	CTL2	CTL1	Output frequency	Baud rate output example (to/16)
0	0	0	0	0	0	0	32768	2048000bits/sec.
0	0	1	0	0	0	0	3276.8	204800
0	1	0	0	0	0	0	16384	1024000
0	1	1	0	0	0	0	10922.6	676412.5
1	0	0	0	0	0	0	8192	512000
1	0	1	0	0	0	0	6553.6	409600
1	1	0	0	0	0	0	5461.3	341328
1	1	1	0	0	0	0	2730.6	170664

Note: Lower digits are omitted.

Baud rate generator

8640CN

CTL1	CTL2	CTL3	CTL4	CTL5	CTL6	Output frequency	Baud rate output example (to/16)
0	0	0	0	0	0	768 kHz	48000bits/sec.
1	0	1	0	0	0	153.6	9600
0	0	1	0	0	0	76.8	4800
0	1	0	0	0	1	38.4	2400
1	0	0	0	0	1	19.2	1200

8650C

CTL1	CTL2	CTL3	CTL4	CTL5	CTL6	Output frequency	Baud rate output example (to/16)
0	0	0	0	0	0	96.0 kHz	60000bits/sec.
1	0	1	0	0	0	19.2	1200
0	0	1	0	0	0	9.6	600
0	1	0	0	0	1	4.8	300
0	1	1	0	0	1	3.2	200
1	0	0	0	0	1	2.4	150
1	1	0	0	0	1	1.6	100
1	1	1	0	0	1	0.8	50

THE CRYSTALMASTER



ENERGY SAVING EPSON

EPSON offers effective savings to its customers through a wide range of electronic devices, such as semiconductors, liquid crystal display (LCD) modules, and crystal devices. These savings are achieved through a sophisticated melding of three different efficiency technologies.

Power saving technology provides low power consumption at low voltages.

Space saving technology provides further reductions in product size and weight through super-precise processing and high-density assembly technology.

Time saving technology shortens the time required for design and development on the customer side and shortens delivery times.

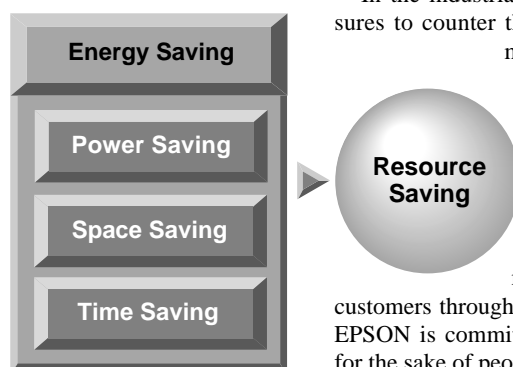

Our concept of Energy Saving technology conserves resources by blending the essence of these three efficiency technologies. The essence of these technologies is represented in each of the products that we provide to our customers.

In the industrial sector, leading priorities include measures to counter the greenhouse effect by reducing CO₂, measures to preserve the global environment, and the development of energy-efficient products. Environmental problems are of global concern, and although the contribution of energy-saving technology developed by EPSON may appear insignificant, we seek to contribute to the development of energy-saving products by our customers through the utilization of our electronic devices. EPSON is committed to the conservation of energy, both for the sake of people and of the planet on which we live.



SEIKO EPSON CORP. QUARTZ DEVICE DIVISION acquired ISO9001 and ISO14001 certification by B.V.Q.I. (Bureau Veritas Quality International) .

ISO9001 in October, 1992.

ISO14001 in November, 1997.

NOTICE

No part of this material may be reproduced or duplicated in any form or by any means without the written permission of Seiko Epson. Seiko Epson reserves the right to make changes to this material without notice. Seiko Epson does not assume any liability of any kind arising out of any inaccuracies contained in this material or due to its application or use in any product or circuit and, further, there is no representation that this material is applicable to products requiring high level reliability, such as, medical products. Moreover, no license to any intellectual property rights is granted by implication or otherwise, and there is no representation or warranty that anything made in accordance with this material will be free from any patent or copyright infringement of a third party. This material or portions thereof may contain technology or the subject relating to strategic products under the control of the Foreign Exchange and Foreign Trade Control Law of Japan and may require an export license from the Ministry of International Trade and Industry or other approval from another government agency.