

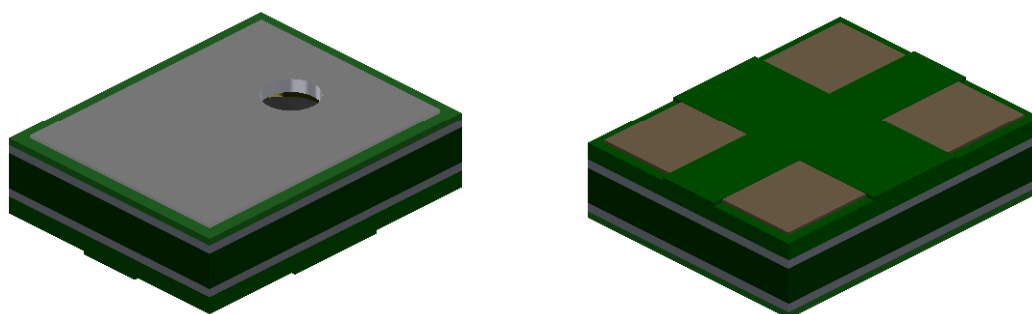

SPM0408HE5H

Amplified "Mini" SiSonic™ Microphone
Specification With Enhanced RF Protection-
Halogen Free



Knowles Acoustics
1151 Maplewood Drive
Itasca, IL 60143



Knowles Acoustics, a division of Knowles Electronics, LLC.

Revision: B
Release Level: ACTIVE
Sheet 1 of 10

1. DESCRIPTION AND APPLICATION

1.1 DESCRIPTION

Amplified "Mini" Surface Mount Silicon Microphone with Enhanced RF Protection.

1.2 APPLICATION

Hand held telecommunication devices.

2. PART MARKING

Identification Number Convention

S 1 2 3

4 5 6 7

S: Manufacturing Location

"S" - Knowles Electronics Suzhou
Suzhou, China

"No Alpha Character" - Knowles Electronics
Itasca, IL USA

"E" - Engineering Samples

Digits 1-7: Job Identification Number

3. TEMPERATURE RANGE

3.1 Operating Temperature Range: -40°C to +100°C

3.2 Storage Temperature Range: -40°C to +100°C

4. ACOUSTIC & ELECTRICAL SPECIFICATIONS

TEST CONDITIONS: +20 °C, 60-70% R.H.

	Symbol	Condition	Limits			Unit
			Min.	Nom.	Max.	
Directivity		Omni-directional	—	—	—	
Sensitivity	S	@ 1kHz (0dB-1V/Pa)	-26	-22	-18	dB
Output Impedance	Z _{OUT}	@ 1kHz (0dB-1V/Pa)	—	—	300	Ω
Current Consumption	I _{DDS}	Across 1.5 to 3.6 volts	100	—	350	μA
Signal to Noise Ratio	S/N	@ 1kHz (0dB-1V/Pa)	55	59	—	dB
Supply Voltage	V _s		1.5	—	3.6	V
Typical Input Referred Noise	ENL	A-weighted	—	35	—	dBA SPL
Sensitivity Loss Across Voltage		Change in sensitivity over 3.6V to 1.5V	No Change Across Voltage Range			dB
Maximum Input Sound Level		At 100dB SPL, THD < 1% At 115dB SPL, THD ≤ 10%				

5. FREQUENCY RESPONSE CURVE

Typical Free Field Response
NORMALIZED TO 1kHz, C1 = 2.2μF

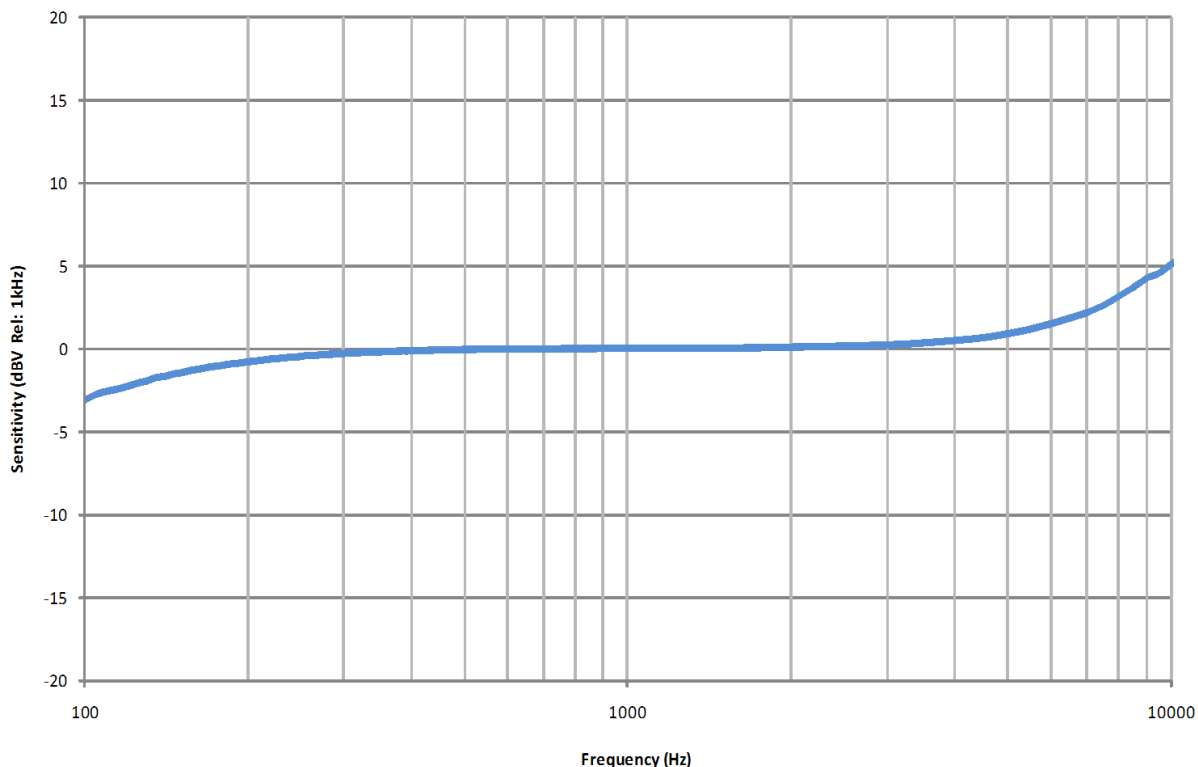

6. MECHANICAL SPECIFICATIONS

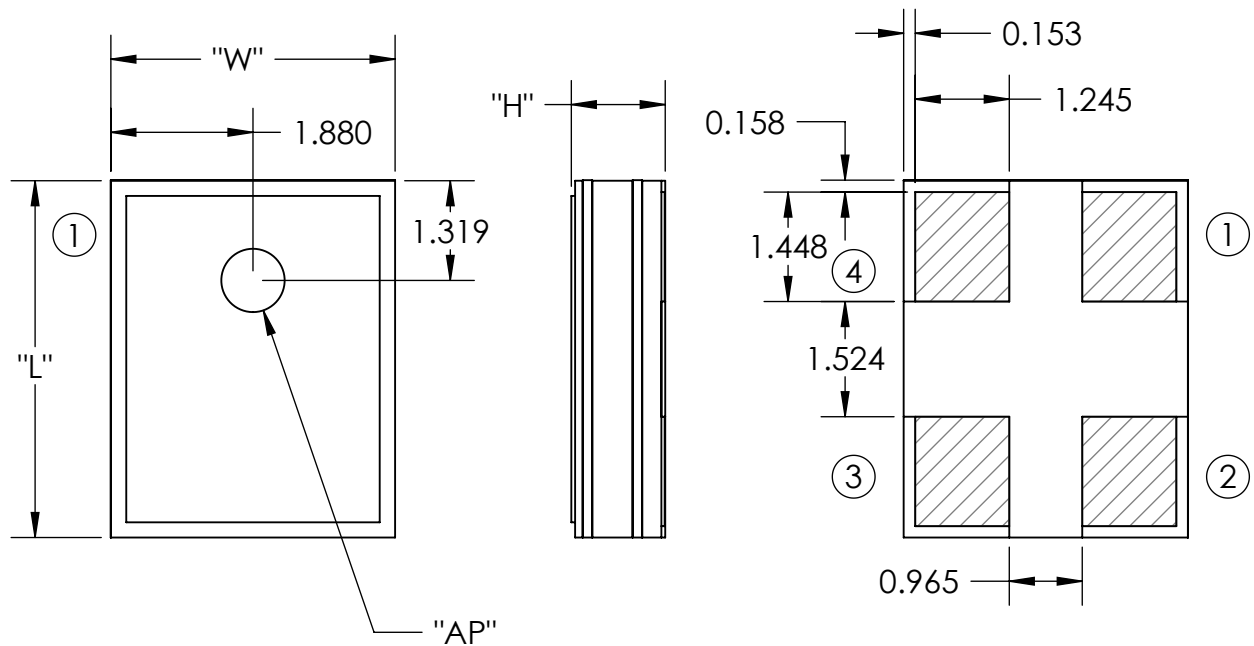

ITEM	DIMENSION	TOLERANCE	UNITS
LENGTH (L)	4.720	±0.100	mm
WIDTH (W)	3.760	±0.100	mm
HEIGHT (H)	1.250	±0.100	mm
ACOUSTIC PORT (AP)	Ø0.838	±0.100	mm

PIN OUTPUT	
PIN #	FUNCTION
1	OUTPUT
2	GAIN
3	GROUND
4	POWER (Vdd)

Note:

Dimensions are in millimeters unless otherwise specified.

Tolerance ±0.15mm unless otherwise specified.

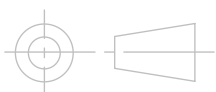

7. RECOMMENDED CUSTOMER LAND PATTERN

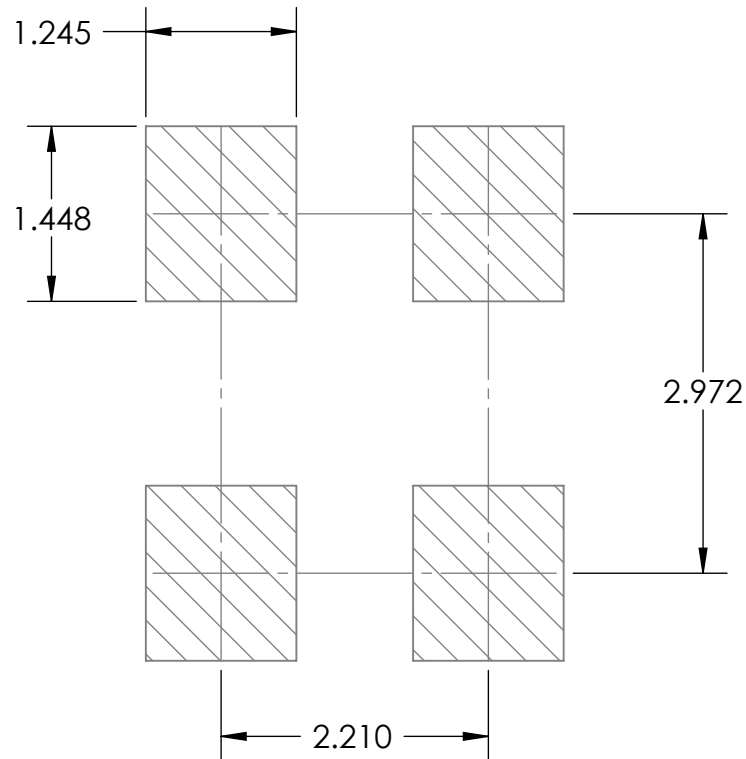

8. RECOMMENDED SOLDER STENCIL PATTERN

N/A

9. RECOMMENDED INTERFACE CIRCUIT

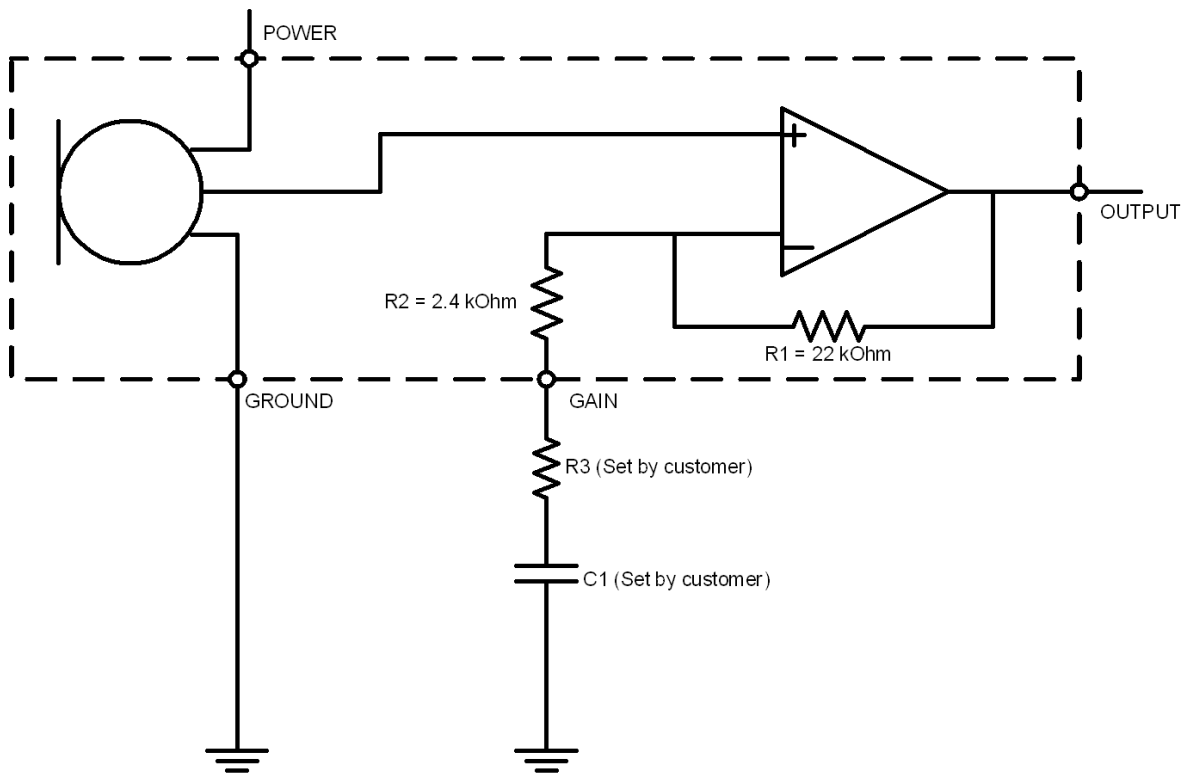

DESIRED GAIN	GAIN PIN TERMINATION METHOD
Unity Gain (0dB)	Tie Gain Pin directly to Output Pin
20dB Gain	Tie Gain Pin through C1 (0.47μF) to Ground
Adjustable Gain	Add Ground Pin and C1. Use formulas provided to calculate settings of contact Knowles for support.

Setting Gain Formulas:

Gain on non-inverting Op-Amp is determined as:

$$\rightarrow G = 1 + \left\{ \frac{R1}{R2 + R3} \right\} \quad \text{Gain(dB)} - 20 * \log(G)$$

High-pass-filter Corner Frequency:

$$\rightarrow \text{C.F.} - 1 / \left\{ 2 * \pi * (R2 + R3) * C1 \right\}$$

SPM0408HE5H

10. PACKAGING DETAIL

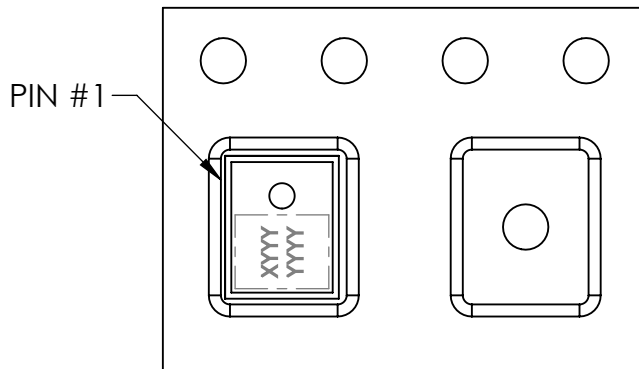
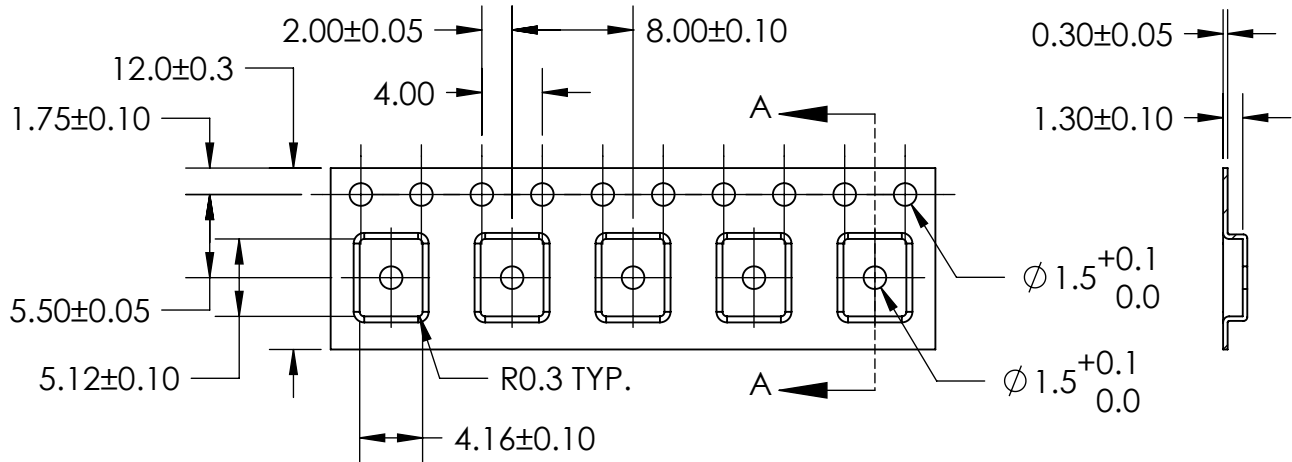

COMPONENT ORIENTATION

MODEL NUMBER	SUFFIX	REEL DIAMETER	QUANTITY PER REEL
SPM0408HE5H	-2	7"	1,200
	-6	13"	4,800

TAPE & REEL	PER EIA-481
LABEL	LABEL APPLIED TO EXTERNAL PACKAGE & DIRECT TO REEL.

Note:

Dimensions are in millimeters unless otherwise specified.

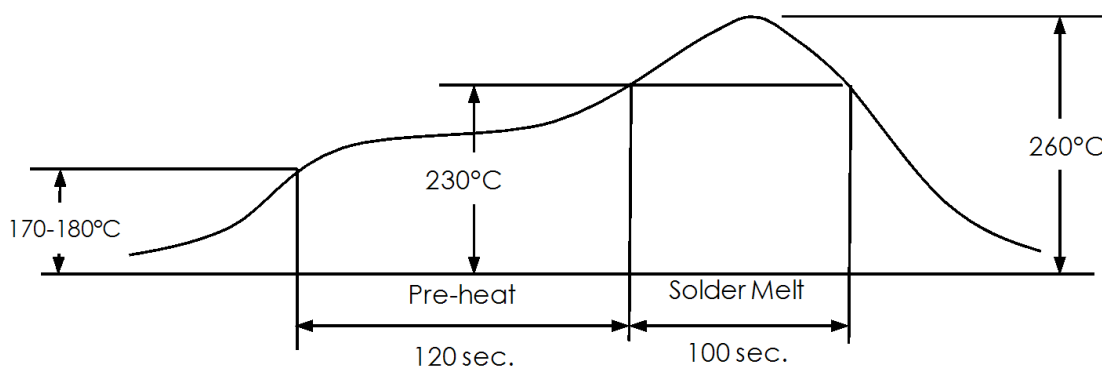
11. SOLDER FLOW PROFILE

Stage	Temperature Profile	Time (maximim)
Pre-heat	170 ~ 180°C	120 sec.
Solder Melt	Above 230°C	100 sec.
Peak	260°C maximum	30 sec.

12. ADDITIONAL NOTES

- (A) Shelf life: Twelve (12) months when devices are to be stored in factory supplied, unopened ESD moisture sensitive bag under maximum environmental conditions of 30°C, 70% R.H. MSL (moisture sensitivity level) Class 2a.
- (B) Do not pull a vacuum over port hole of the microphone. Pulling a vacuum over the port hole can damage the device.
- (C) Do not board wash after the reflow process. Board washing and cleaning agents can damage the device. Do not expose to ultrasonic processing or cleaning.
- (D) Do not brush board after the reflow process. Brushing the board with/without solvents can damage the device.
- (E) Do not insert any object in port hole of device at any time as this can damage the device.
- (F) Number of reflow - Recommend no more than 3 cycles.

13. RELIABILITY SPECIFICATIONS

Note: After test conditions are performed, the sensitivity of the microphone shall not deviate more than 3dB from its initial value.

Test	Description
Thermal Shock	100 cycles of air-air thermal shock from -40°C to +125°C with 15 minute soaks. (ICE 68-2-4)
High Temperature Storage	+105°C environment for 1,000 hours. (ICE 68-2-2 Test Ba)
Low Temperature Storage	-40°C environment for 1,000 hours. (ICE 68-2-2 Test Aa)
High Temperature Bias	+105°C environment while under bias for 1,000 hours. (ICE 68-2-2 Test Ba)
Low Temperature Bias	-40°C environment while under bias for 1,000 hours. (ICE 68-2-2 Test Aa)
Temperature / Humidity Bias	+85°C/85% R.H. environment while under bias for 1,000 hours. (JESD22-A101A-B)
Vibration	4 cycles lasting 12 minutes from 20 TO 2,000 Hz in X, Y and Z direction with peak acceleration of 20g. (MIL 883E, Method 2007.2, A)
Electrostatic Discharge	3 discharges at +/-8kV direct contact to lid when unit is grounded (IEC 61000-4-2) and 3 discharges at +/-2kV direct contact to I/O pins. (MIL 883E, Method 3015.7)
Reflow	5 reflow cycles with peak temperature of +260°C.
Mechanical Shock	3 pulses of 10,000g in the X, Y and Z direction. (IEC 68-2-27, Test Ea)

