

SPRF2411A-001

2.4GHz 32CH 2way RF Optical / Laser Tilt-Wheel Mouse SoC

Preliminary

APR. 26, 2010

Version 0.97

2.4GHZ 32CH 2WAY RF OPTICAL/LASER TILT-WHEEL MOUSE SOC

1. FEATURES

1.1. Mouse Features

- Decodes mouse sensor automatically for mouse X-Y direction:
 - Avagotech - A7530; A7050; A5030; A5090; A3040
 - Pixart – P3204; P3204L; P3603
- Displacement tracking speed : 12 ~ 20 inches/Sec
- Sensor orientation Vertical or Horizontal strap for mouse shape (see section 5.1)
- Flexible support numbers of buttons:
 - Left; Middle; Right button for standard and side_up; side_down for extended button
 - 2 tilt buttons (left / right) decode for horizontal scrolling
 - 2 customized buttons for Multimedia / Internet hot-keys
- In-use Sensitivity Switching to high and low CPI for 2 segment resolution with LED indicator through “CPI_SW” button and no software driver required.
- Resolution CPI-LED blinking indicator (see section 5.2)
 - High (1600 / 1000) CPI = LED blinking 2 seconds with 12Hz
 - Low (800 / 500) CPI = LED blinking 2 seconds with 2Hz
- Supports mechanical wheel encoding (1:2)
- High speed mouse report rate up to 125 report/s
- Supports LOP ALPC system to comply IEC 60825-1 eye safety
- SunplusIT software driver available for Tilt-button enable

1.2. Comments Features

- Component Reduction:
 - Integrated high efficiency DC/DC converter
 - Built-in internal 6MHz oscillator and one output clock to external mouse sensor.
 - Built-in EEPROM (128 Bytes) used for Channel; ID and RF test memorizes.
- Low Operating Voltage from 1.8V to 4.2V

1.3. 2.4GHz RF Features

- 2.4GHz GFSK RF transceiver
- 32 channels hopping with 2 group form 2.405GHz ~ 2.476GHz. (see section 6)
- Sensitivity up to -93 dBm (@ 250kbps)
- Output power up to 0 dBm
- Low-noise amplifier, power amplifier, modern and data slicer/recovery on chip
- High speed RF link data rate Max. 1M bit/s
- 24 bits ID number (16777216 combinations): allows the receiver to identify its mouse
- 1 connect (bind) button for RF link sync or Auto connect while Power on (batteries insert)

1.4. Power Management Features

- Smart power On / Off via BIND button (One-touch) or RF disconnected
- Support 5 stages of operate mode for smart battery power saving
 - Active mode: when activity (movement; buttons; scrolling) is detected
 - Idle mode: when inactivity (without movement; buttons; scrolling) within 5 Sec
 - Standby mode: Idle mode occurred after 5 Sec. entrance
 - Wait mode: Standby mode occurred after 60 Sec. entrance
 - Suspend mode: Wait mode occurred after 10 min. entrance

1.5. Package

- 40Pin QFN 6 X 6 mm package available.

2. BLOCK DIAGRAM

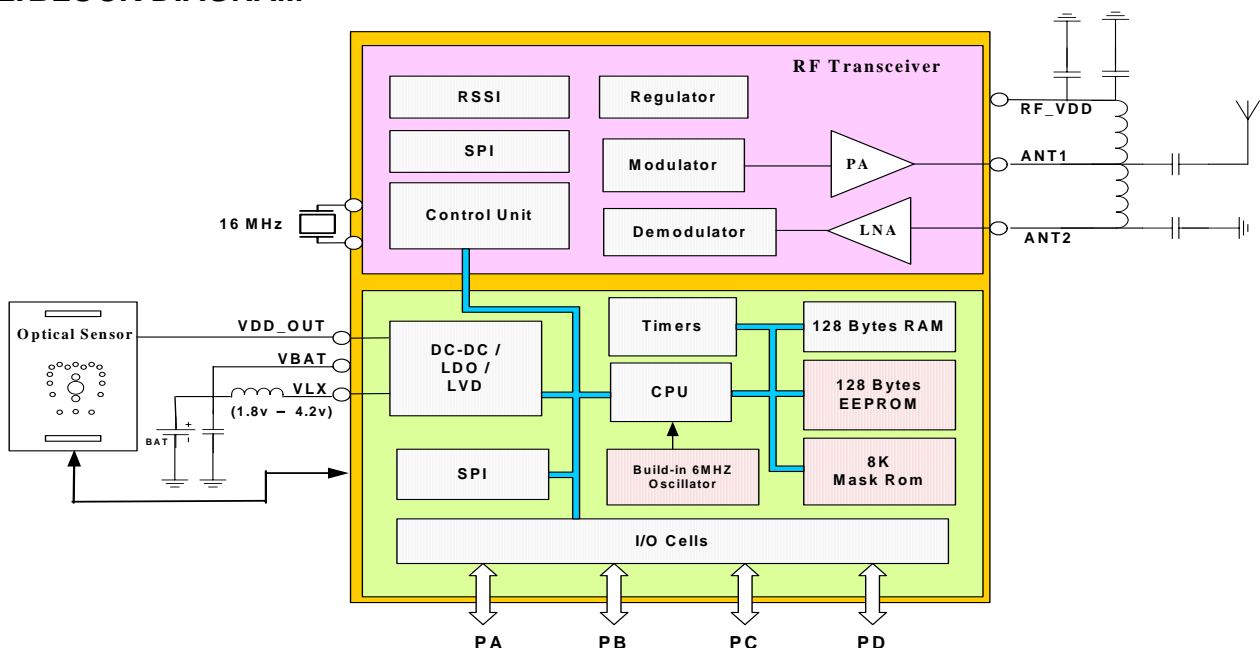

3. SIGNAL DESCRIPTIONS

3.1. PIN Descriptions

IC Name	PIN No.	I/O	Function Description
VBAT	1	I	Battery power in and low power detection
VDD_OUT	2	O	DC/DC output (for whole system power)
TEST	3	-	Reserved for internal test only
VLX	4	O	DC/DC Lx switch output
BAT_L	5	I	Battery low voltage detection input
VSS	6	P	System ground
NCS	7	B	Optical Sensor SPI / Sensor Chip Select / Sensor CLKOUT
VDD	8	P	System power
RF_PSBO	9	O	RF digital output. Assert to force RF to enter Power-Saving Mode or Power-Down Mode, depended on the state of TRRDY.
RF_VCCD	10	P	RF digital power
RF_GNDD	11	P	RF digital ground
RF_VDDD	12	P	RF digital decoupling power pin
RF_XOUT	13	O	16MHz Crystal output
RF_XIN	14	I	16MHz Crystal input
RF_PSB	15	B	RF digital input. Assert to force RF to enter Power-Saving Mode or Power-Down Mode, depended on the state of TRRDY.
RF_VCOG	16	P	RF VCO ground
RF_VCOPG	17	P	RF VCO frame ground
RF_VCOVDD	18	P	RF VCO power
RF_VDD	19	P	RF power
ANT1	20	B	RF signal pin, Antenna I/F
ANT2	21	B	RF signal pin, Antenna I/F
RF_GNDPG	22	P	RF frame ground
RF_GND	23	P	RF ground.
RF_VCC	24	P	RF power
GND_IF	25	P	RF Analog IF ground
MISO	26	B	MCU SPI Slave Data output
S0	27	B	Key matrix scan line Column 0
R2	28	B	Key matrix scan line Row 2
R1	29	B	Key matrix scan line Row 1
R0	30	B	Key matrix scan line Row 0
S1	31	B	Key matrix scan line Column 1
R4	32	B	Key matrix scan line Row 4
R3	33	B	Key matrix scan line Row 3
ESCLK	34	O	MCU SPI Clock output
MOSI (DIR2)	35	B	MCU SPI Slave Data input / Strap for sensor orientation (See section 5)
ZA	36	I	Z-Wheel phase A
ZB	37	I	Z-Wheel phase B
BIND	38	B	RF Connection Button / Battery low (CPI)-LED indicator
DIR (DIR1)	39	I	Strap for sensor orientation (See section 5)
MOTION / PD	40	B	Mouse Sensor Motion pin input / Power down pin for optical sensor only

3.2. PIN Assignment

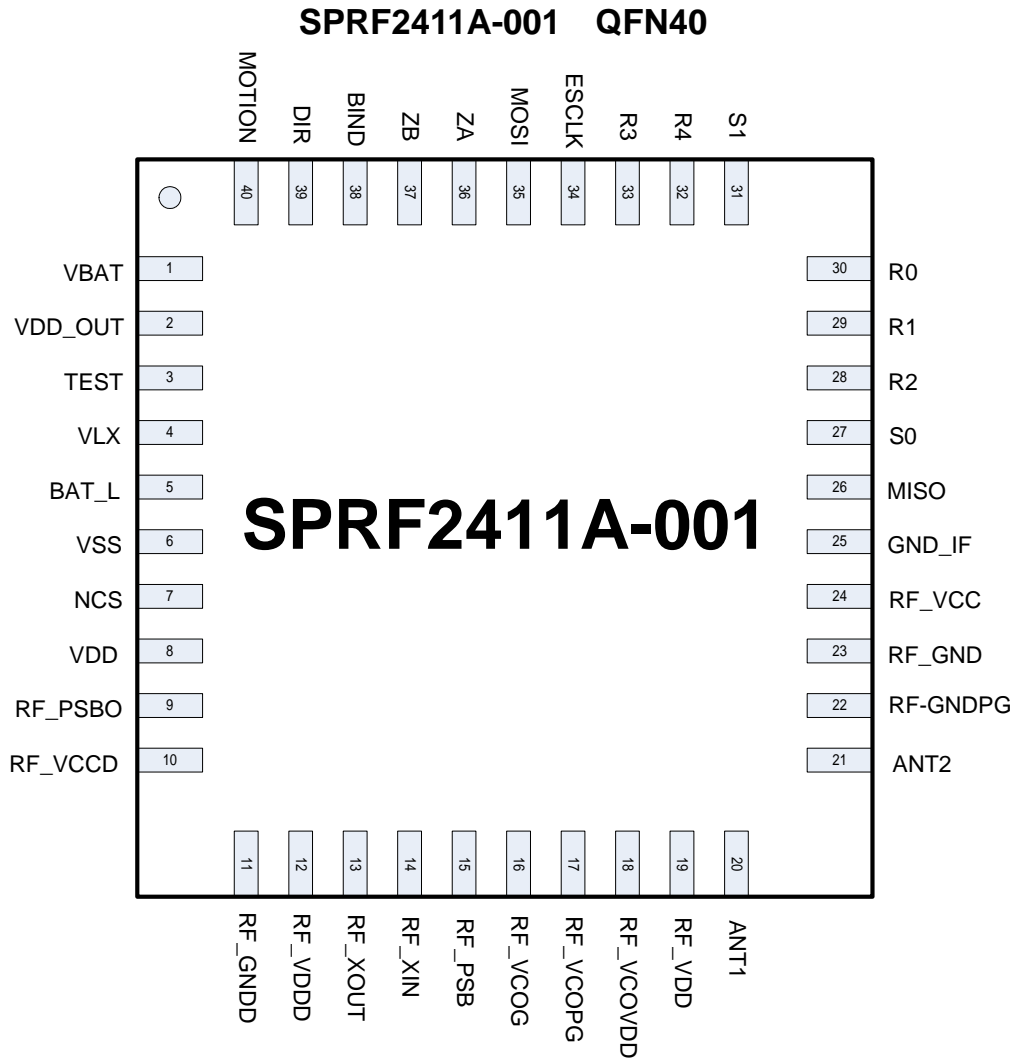

4. APPLICATION BLOCK DIAGRAM

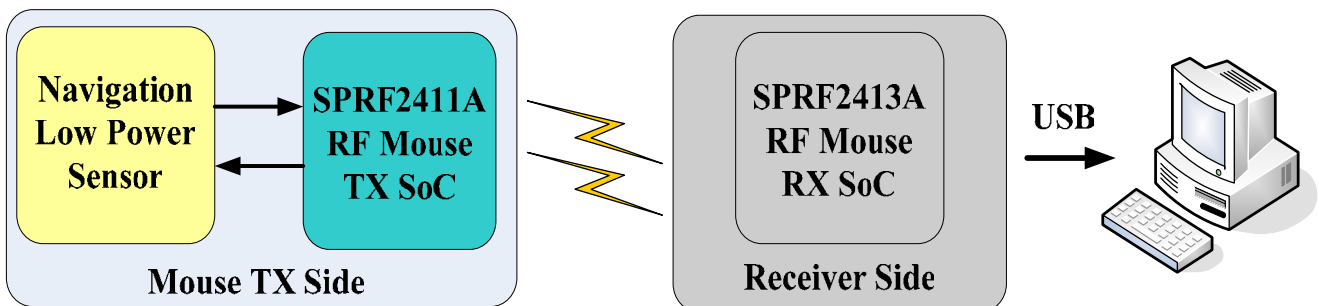

5. SENSOR ORIENTATION STRAPS & CPI RESOLUTION DEFINITION

5.1. Sensor Orientation Straps

Sensor Orientation Straps	DIR1	DIR2
0 degree (Vertical)	NC	NC
90 degree (Horizontal)	Pul up (High)	NC
180 degree (-Vertical)	NC	Pull down (Low)
270 degree (-Horizontal)	Pull up (High)	Pull down (Low)

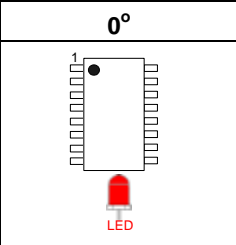
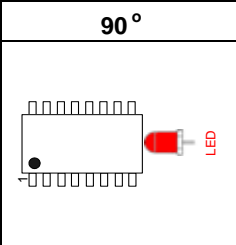
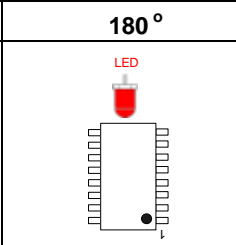
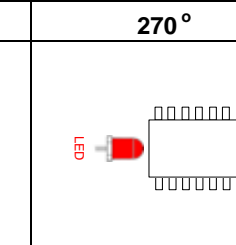
Generics Sensor Orientation Description			
0°	90°	180°	270°
			

5.2. Sensor CPI Resolution Listing both High and Low CPI

Sensor Type	High CPI	Low CPI
Avago ADNS-7530	1600	800
Avago ADNS-7050	1600	800
Avago ADNS-5090	1000	500
Avago ADNS-5030	1000	500
Avago ADNS-3040	1600	800
Pixart PAN3603	1600	800
Pixart PAN3204/PAN3204L	1600	800

6. FREQUENCY HOPPING TABLE

Frequency Group1		Frequency Group2		Unit
2407	2442	2405	2443	[MHz]
2408	2447	2406	2444	
2412	2451	2409	2446	
2414	2452	2410	2448	
2417	2457	2411	2449	
2420	2458	2413	2453	
2421	2459	2415	2455	
2422	2460	2416	2456	
2427	2461	2418	2462	
2428	2465	2419	2463	
2431	2468	2423	2464	
2435	2469	2425	2466	
2436	2472	2429	2467	
2437	2473	2430	2470	
2438	2475	2432	2471	
2439	2476	2434	2474	

7. BUTTONS KEY SCAN MATRIX DEFINITION

Numbers in gray are Function key number

Row 0 (R0)	Row 1 (R1)	Row 2 (R2)	Row 3 (R3)	Row 4 (R4)	
1	3	2	3	4	Column0 (S0)
LB (Left button)	RB (Right button)	MB (Middle button)	B4_UP (Side_up button)	B5_DN (Side_dn button)	
6	7	9	10	8	Column0 (S1)
TILT-Right	TILT-Left	Customized Key_1	Customized Key_2	ISS button CPI_SW	

8. KEY ELECTRICAL SPECIFICATIONS

8.1. Absolute Maximum Rating

Characteristics	Symbol	Min.	Typ.	Max.	Unit	Test Condition
Storage Temperature	T_{STR}	-40	-	125	°C	Non-programmed Device
Storage Temperature	T_{STR}	0	-	85	°C	Programmed Device
Voltage Rating on Input	V_{IN}	-0.3	-	VDD+0.3	V	
Voltage Rating on VDD	-	-0.3	-	4.2	V	
Output Voltage	V_{OUT}	0	-	VDD	V	

Note: Stresses beyond those given in the Absolute Maximum Rating table may cause operational errors or damage to the device. For normal operational conditions see AC/DC Electrical Characteristics.

8.2. Recommended Operating Conditions

Characteristics	Symbol	Min.	Typ.	Max.	Unit	Test Condition
Operating Supply Voltage	VBAT	1.8	-	4.2	V	
	VDD	-	3.0	-	V	Radio Side
Operating Ambient Temperature	T_{OPR}	0	-	70	°C	

8.3. AC Characteristics

Description	Symbol	Min.	Typ.	Max.	Unit	Test Condition
MCU Parameter						
Internal R oscillator frequency	F_{ROSC}	1.75	3.5	5.25	KHZ	
Internal 6MHz oscillator frequency	F_{OSC6M}	5.9	6.0	6.1	MHZ	$F_{OSC6M} / 2$ for MCU clock
Radio Parameter						
Crystal Frequency	F_{RF_OSC}		16		MHZ	Frequency Tolerance=30ppm
Frequency deviation	F_{RF_DEV}	-100	-	+100	KHZ	
Data Rate	Burst Mode	-	>0	-	1000	Kbps
	Direct Mode	-	250	-	1000	Kbps
Channel Spacing	-	-	1	-	MHZ	

8.4. DC Characteristics

Name	Description	Symbol	Min.	Typ.	Max.	Unit	Test Condition
VDD	Power Consumption (1Mbps)	I_{DD} (avage)	-	-	TBD	mA	VDD = 3.3V, 2-way, 18bytes/8ms CPU speed=3MHz
	Power Consumption (250Kbps)		-	-	TBD		
	Suspend Current	I_{SUSP}	-	-	TBD	uA	VDD = 3.3V
	Low voltage Reset	V_{LVRZ}	-	2.4 or 2.2	-	V	
VDD_OUT	Current Supply capability	I_{RGL}	90	-	-	mA	@5% voltage drop
	output voltage	V_{OV}	2.6	2.8	3.0	V	DCDC_VOL_SEL = 0
	Startup Voltage	V_{SU}	1.8	-	-	V	Iload=50mA
	DC/DC Efficiency	E_{ff}	-	92	-	%	Iload=40mA, VDD_OUT=3.3V Vin=1.8 ~ 2.8V
VBAT	Low Voltage Detect	V_{LVDZ} (2 CELL)	1.8	2.0	2.8	V	Factory default= 2.0V
		V_{LVDZ} (1 CELL)	-	V_{LVDZ} (2 CELL)/2	-	V	Factory default= V_{LVDZ} (2 CELL)/2
GPIOs	Input Voltage High	V_{IH}	1.9	-	-	V	VDD = 3.3V
	Input Voltage Low	V_{IL}	-	-	1.0	V	VDD = 3.3V
	Input Leakage Current	I_{IZ}	-	-	10	uA	Internal pull-down disabled

Name	Description	Symbol	Min.	Typ.	Max.	Unit	Test Condition
GPIOs	Output Voltage High	V _{OH}	2.0	-	-	V	@ 2/4/8 mA IOH, Note A, VDD = 3.3V
	Output Voltage Low	V _{OL}	-	-	0.5	V	@ 2/4/8/16 mA IOL, Note A, VDD = 3.3v
	Pull-down Resistor	R _{PD}	70	100	130	KΩ	Measured at PAD = 3.3V
	Pull-up Resistor	R _{PU}	70	100	130	KΩ	Measured at PAD = 0V

8.5. Radio Characteristics

Description	Symbol	Min.	Typ.	Max.	Unit	Test Condition
Transmit Output Power	-	-	0	4	dBm	
Transmit Output Power Control Range	-	16	20	-	dBm	
Transmit Output Power Control Step	-	-	5	-	dB	
20dB Bandwidth for Modulation Carrier	-	-	1000	-	KHz	
2 nd Adjacent TX Power 2MHz	-	-	-	-20	dBm	
3 rd Adjacent TX Power 3MHz	-	-	-	-40	dBm	
Sensitivity	-	-	-93	-	dBm	0.1% BER@250Kbps
		-	-85	-	dBm	0.1% BER@1Mbps
C/I Co-Channel	-	-	9	-	dB	250Kbps
		-	5	-	dB	1Mbps
C/I 1MHz	-	-	-20	-	dB	250Kbps
		-	1	-	dB	1Mbps
C/I 2MHz	-	-	-36	-	dB	250Kbps
		-	-22	-	dB	1Mbps
C/I 3MHz	-	-	-45	-	dB	250Kbps
		-	-35	-	dB	1Mbps
C/I _{Image}	-	-	-30	-	dB	250Kbps
		-	-30	-	dB	1Mbps
Radio Function Current ; MCU=sleep; V_{DD}=3.0V						
Standby Mode	I _{RF_STBY}		22		uA	F _{osc} =16MHz
RF Tx mode during transmit	I _{RF_TX}		13		mA	during transmit @0 dBm
RF Tx mode during transmit	I _{RF_TX}		10.5		mA	during transmit @-5 dBm
RF Tx mode during transmit	I _{RF_TX}		9		mA	during transmit @-10 dBm
RF Tx mode during transmit	I _{RF_TX}		8.2		mA	during transmit @-20 dBm
RF Rx mode during receive	I _{RF_RX}		18		mA	during receive @ 250Kbps
RF Rx mode during receive	I _{RF_RX}		19		mA	during receive @ 1Mbps

9. APPLICATION REFERENCE CIRCUIT

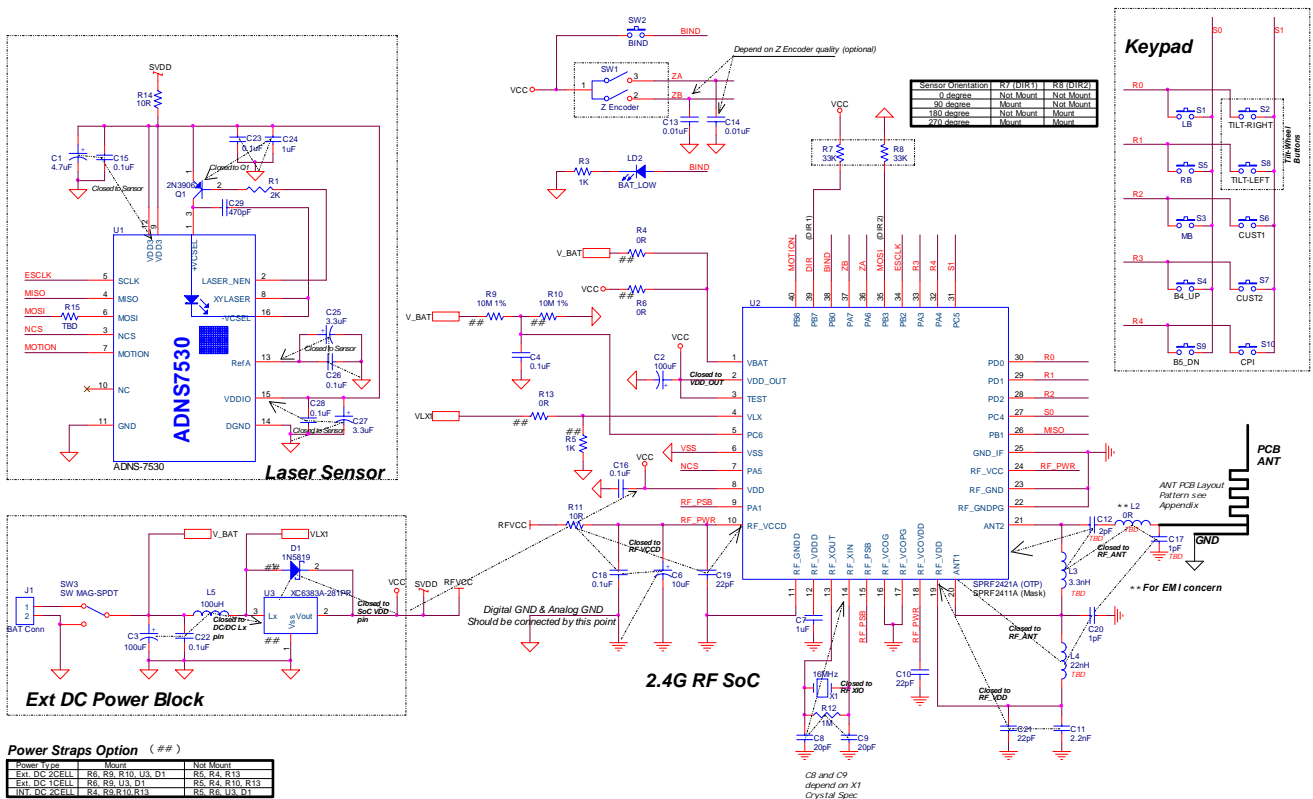

2.4GHz RF Mouse SoC device application circuitry (with A7530)

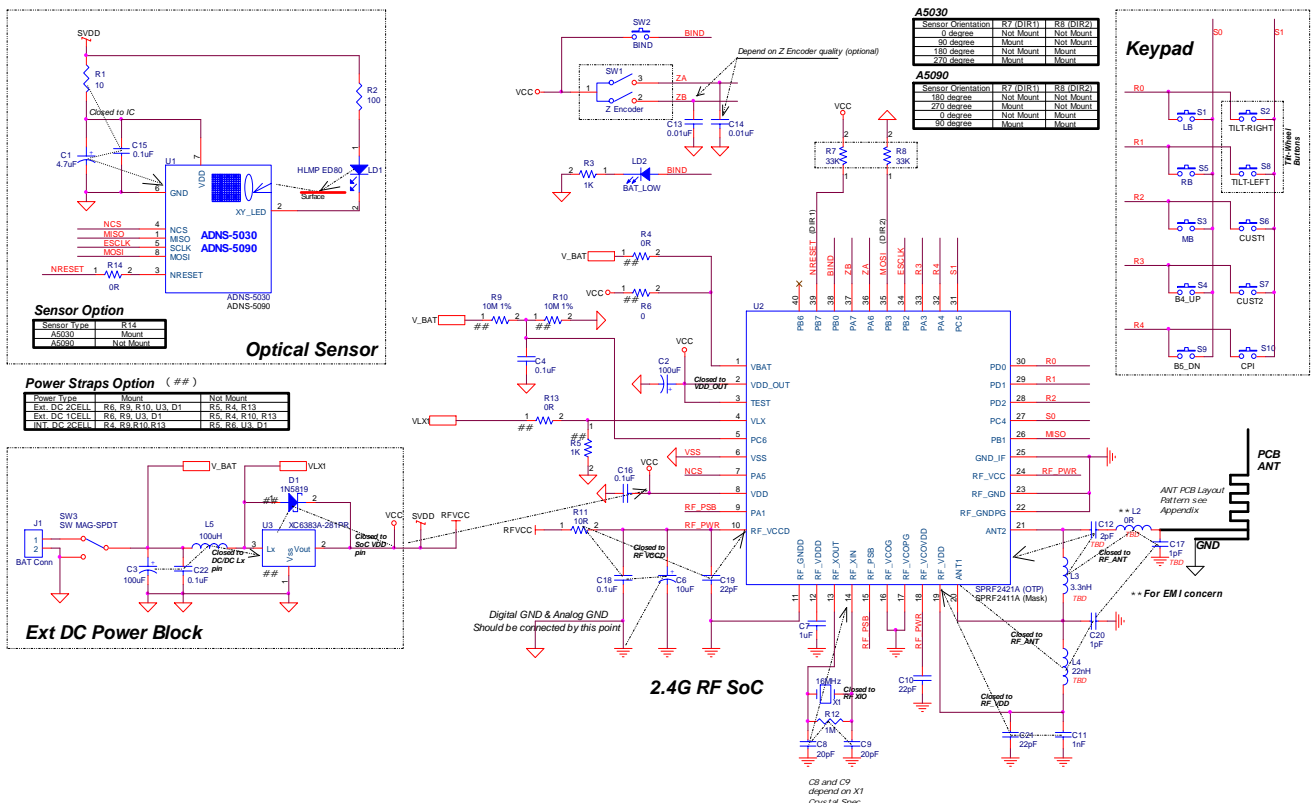

2.4GHz RF Mouse SoC device application circuitry (with A5030 or A5090)

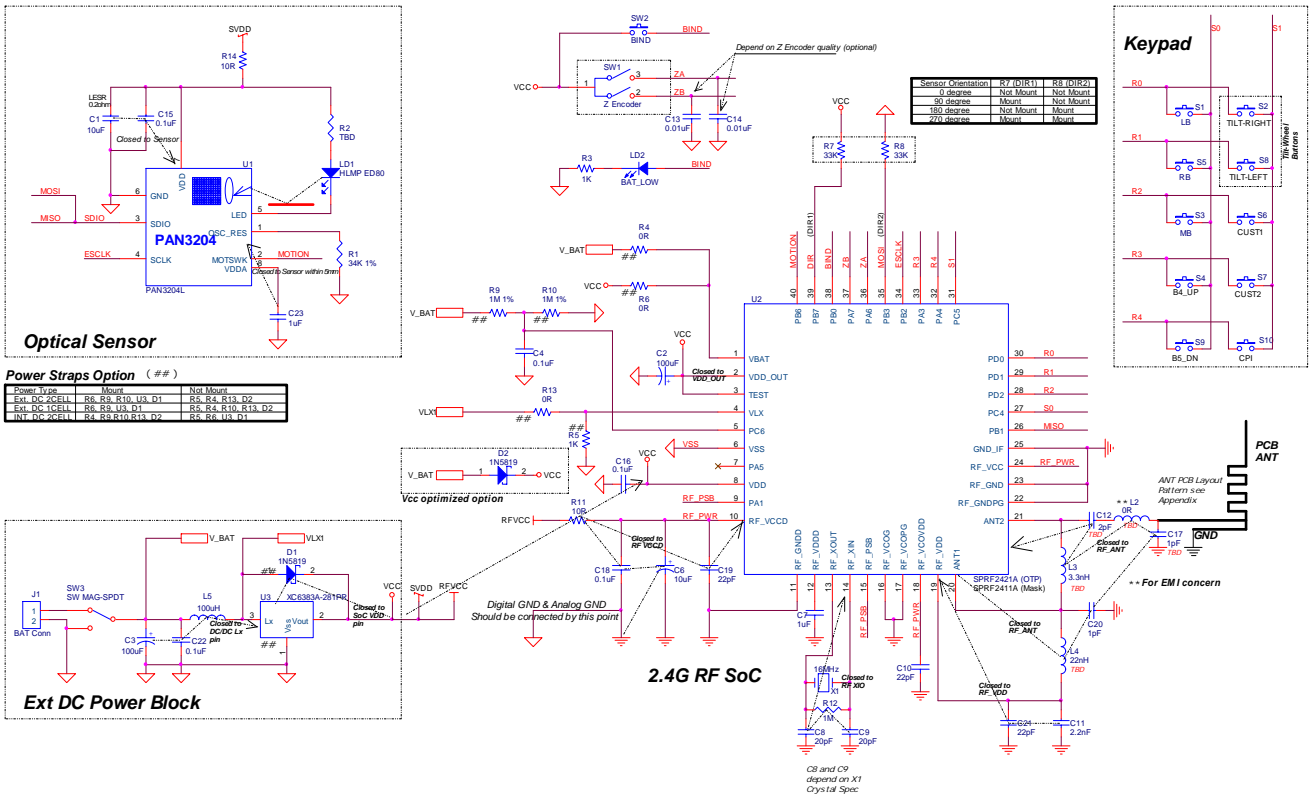

2.4GHz RF Mouse SoC device application circuitry (with PAN3204)

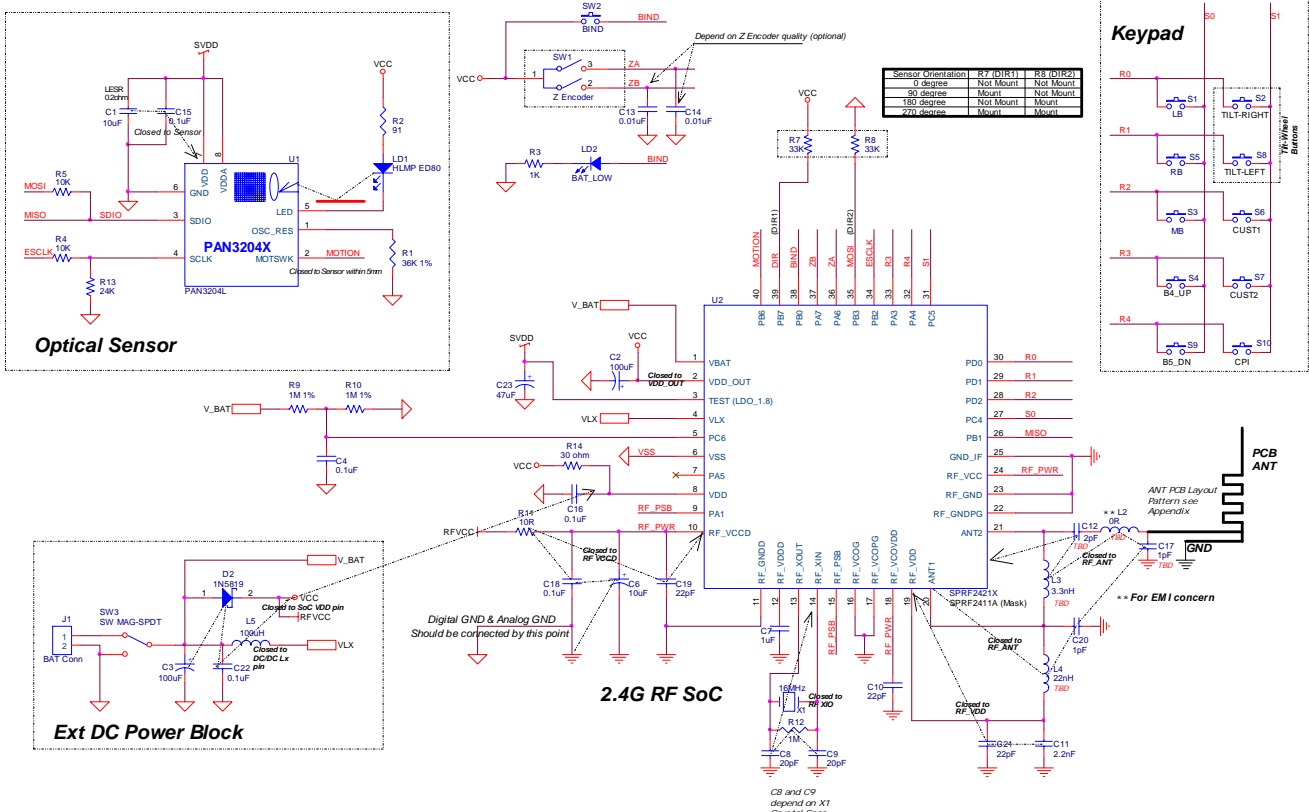

2.4GHz RF Mouse SoC device low-power application circuitry (with PAN3204L)

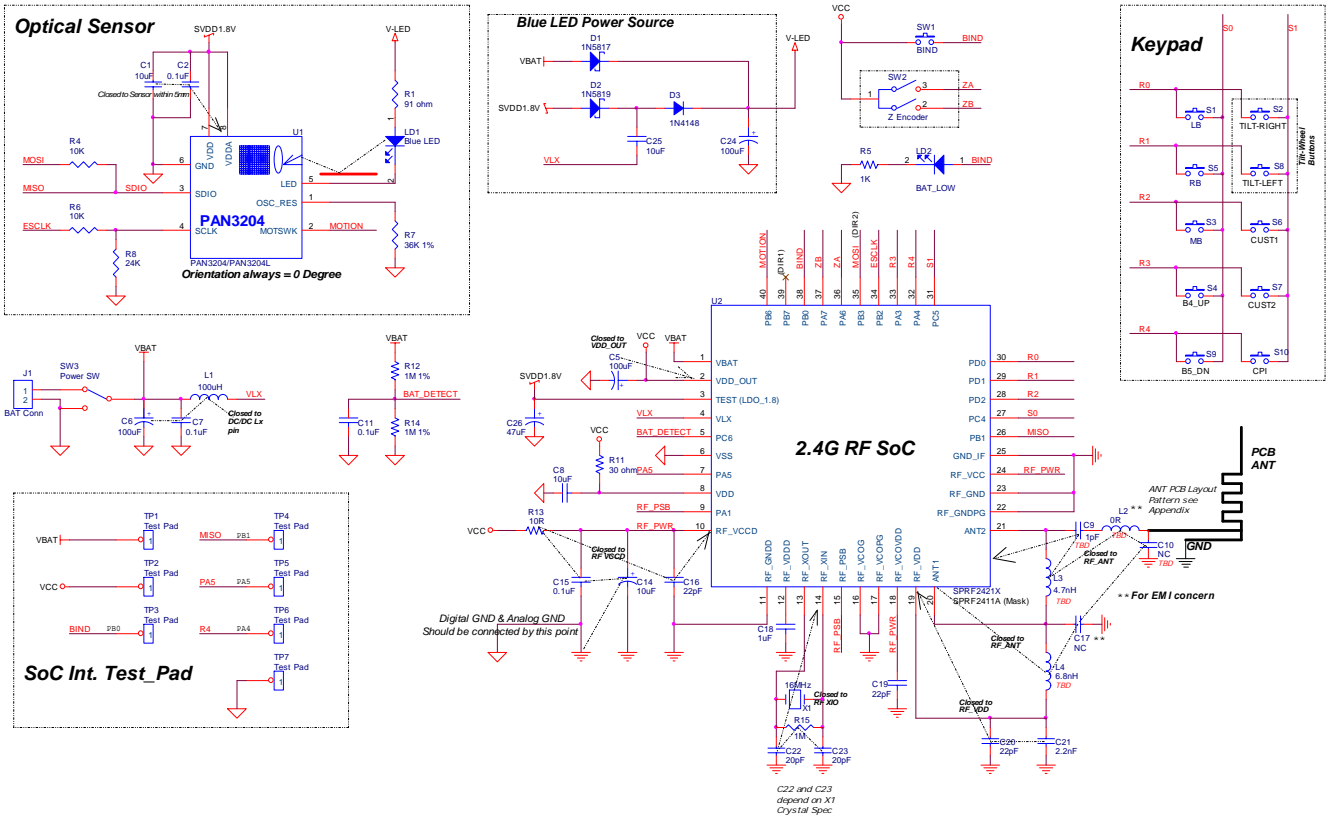

2.4GHz RF Mouse SoC device low-power application circuitry (with PAN3204L + Blue LED)

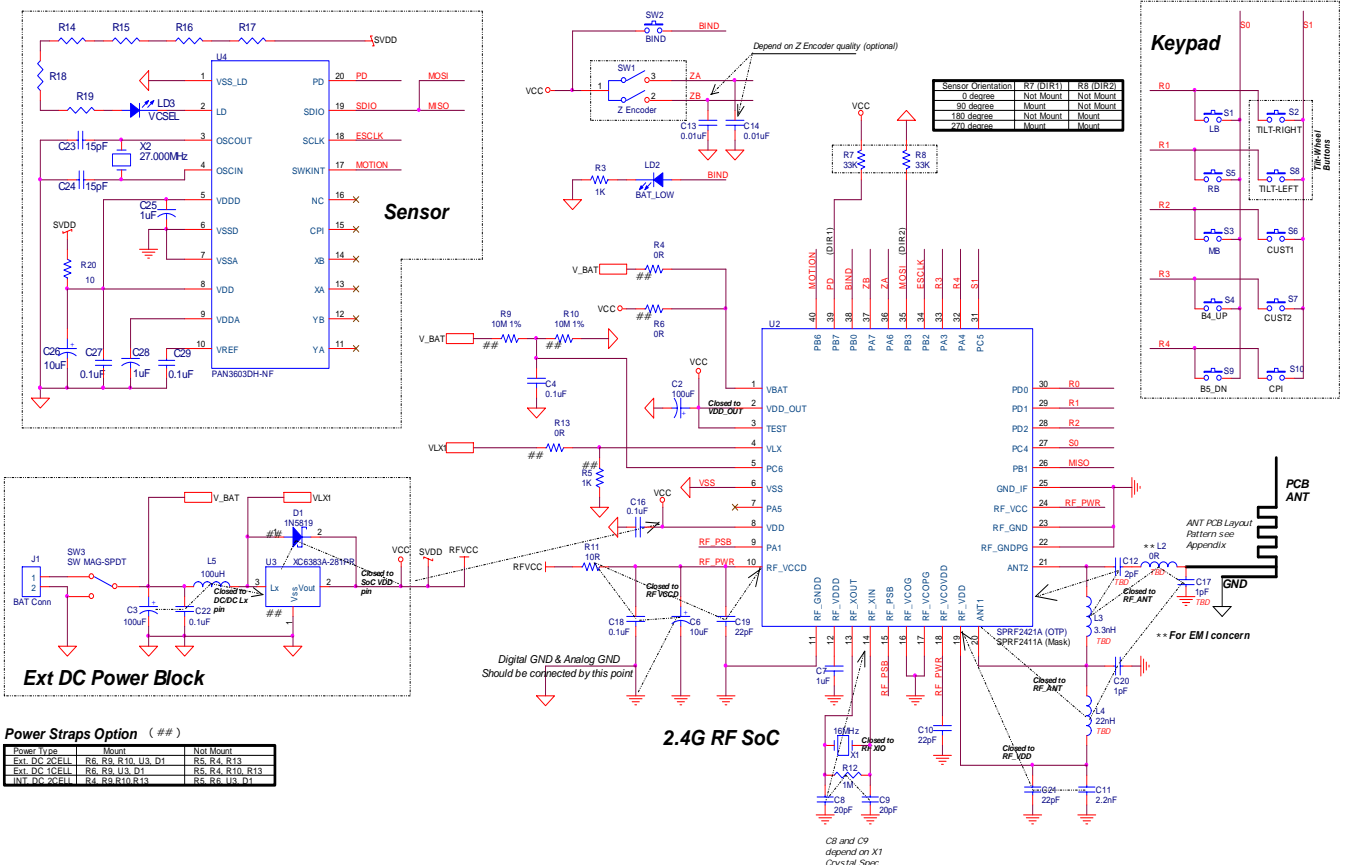

2.4GHz RF Mouse SoC device application circuitry (with PAN3603)

10. PACKAGE DIMENSION

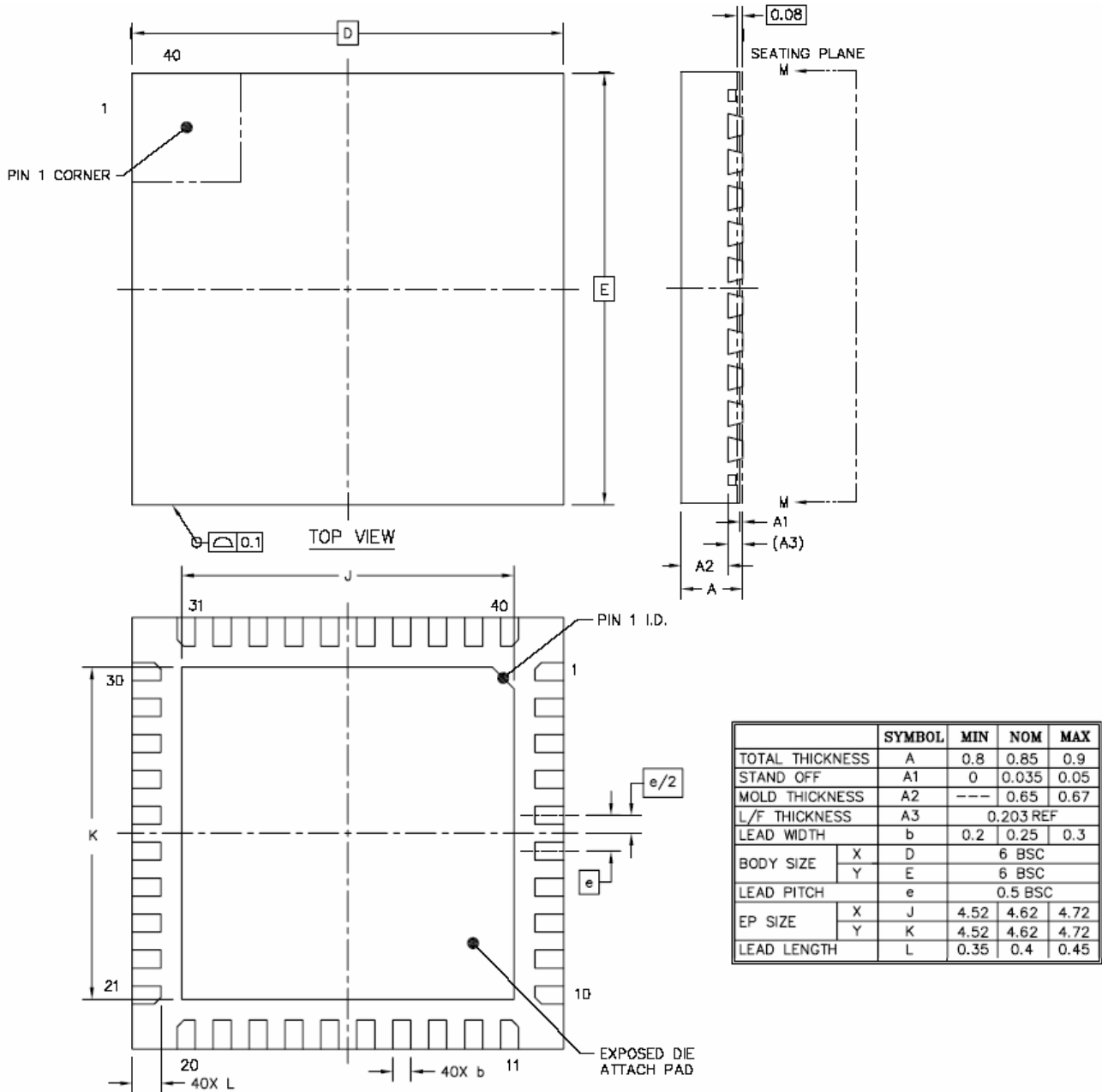

11. ORDERING INFORMATION

Product Number	Package Type
SPRF2411A-001x-HV05A	Package form – 6 x 6mm QFN

Notes: Above ordering information are for the green packages (default) only