

## Cool bypass switch for photovoltaic applications

### Features

- $I_F = 16\text{ A}$ ,  $V_R = 40\text{ V}$
- Very low forward voltage drop
- Very low reverse leakage current
- $175\text{ }^\circ\text{C}$  operating junction temperature

### Applications

- Photovoltaic panels

### Description

The SPV1001 is a system-in-package solution for photovoltaic applications to perform cool bypass rectification similar to that of a conventional Schottky diode but with much lower forward voltage drop and reverse leakage current.

The device consists of a power MOSFET transistor which charges a capacitor during the OFF time, and drives its gate during the ON time using the charge previously stored in the capacitor.

The ON and OFF times are set to reduce the average voltage drop across the drain and source terminals, resulting in reduced power dissipation.

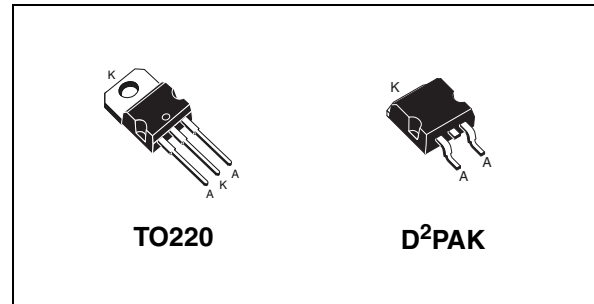

**Table 1. Device summary**

Order codes	Package	Packaging
SPV1001D40	D <sup>2</sup> PACK	Tube
SPV1001D40TR		Tape and reel
SPV1001T40	TO220	Tube

# 1 Maximum ratings

## 1.1 Absolute maximum ratings

**Table 2. Absolute maximum ratings**

Symbol	Parameter	Range [min, max]	Unit
$V_R$	Max DC reverse voltage	40	V
$I_F$	Max. forward current	16	A
$I_{FSM}$	Non repetitive peak surge (half-wave, single-phase, 60 Hz)	250	A
ESD level	Human body level	$\geq 8$ k	V

## 1.2 Thermal data

**Table 3. Thermal data**

Symbol	Parameter	Value	Unit
$R_{thJC}$	Thermal resistance, junction-to-ambient (D <sup>2</sup> PAK, TO220)	1.5	°C/W
$T_J$	Junction temperature operating range	-40 to 175	°C
$T_{STG}$	Storage temperature range	-40 to 175	°C

## 2 Electrical characteristics

**Table 4. Electrical characteristics**

Symbol	Parameter	Test condition		Values			Unit
				Min	Typ	Max	
$V_{F,AVG}$	AVG forward voltage drop	$I_F = 16A^{(1)}$	$T_J = 25^\circ C$	-	230	-	mV
			$T_J = 125^\circ C$	-	270	-	mV
		$I_F = 8A^{(1)}$	$T_J = 25^\circ C$	-	120	-	mV
$I_R$	Reverse leakage current	$V_R = 40V$	$T_J = 25^\circ C$	-	1	-	$\mu A$
			$T_J = 125^\circ C$	-	10	-	$\mu A$
D	TON/T ratio	$I_F = 8A^{(1)}$	$T_J = 25^\circ C$	-	95%	-	-
			$T_J = 125^\circ C$	-	75%	-	-
$V_F$	Forward voltage drop	$I_F = 8A, T_{OFF}$	$T_J = 25^\circ C$	-	920	-	mV
			$T_J = 125^\circ C$	-	600	-	mV
		$I_F = 8A^{(1)}, T_{ON}$	$T_J = 25^\circ C$	-	70	-	mV
			$T_J = 125^\circ C$	-	160	-	mV

1. For correct power dissipation and heatsink sizing, please refer to [Figure 1,4 e 7](#)

## 3 Device description

A photovoltaic panel consists of a series of PV cells. In optimal conditions, all the cells are equally irradiated and function at the same current level. However, during normal operation some cells may become partially shaded or obscured. These shaded cells limit the current generated by the fully irradiated cells and, in the extreme cases where these cells are totally obscured, the current flow is blocked.

In this case the shaded cells behave like a load, and the current generated from the fully irradiated cells produces overvoltages which can reach the breakdown threshold. This phenomenon, known as a “hot spot”, can cause overheating of the shaded cells and, in some cases, even permanent damage resulting in current leakage. To prevent hot spots, therefore, bypass diodes are connected in parallel to the cell strings.

The device described here has the same functionality as a Schottky diode, but with improved performance. It features very low forward voltage drop and reverse leakage current. It consists of a power MOSFET transistor which charges a capacitor during the OFF time, and drives its gate during the ON time using the charge previously stored in the capacitor. The ON and OFF times are set to reduce the average voltage drop across the drain and source terminals, resulting in reduced power dissipation.

Figure 1. Average forward power dissipation vs average forward current

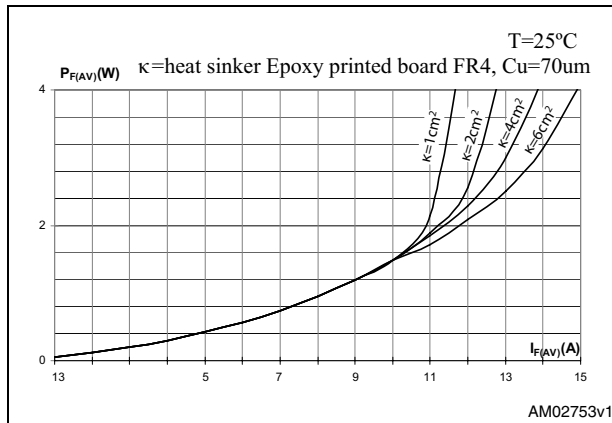

Figure 2. Forward voltage

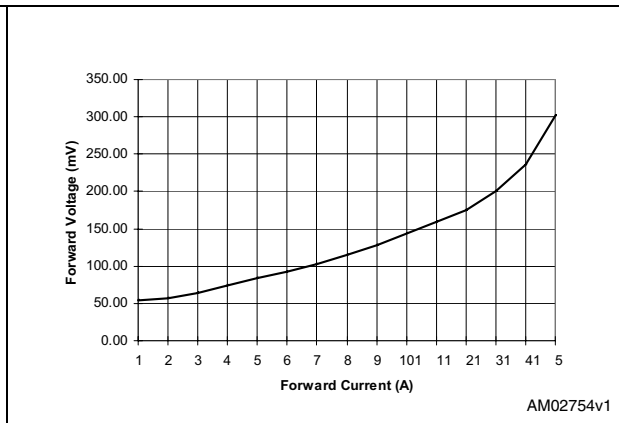

Figure 3. Reverse current

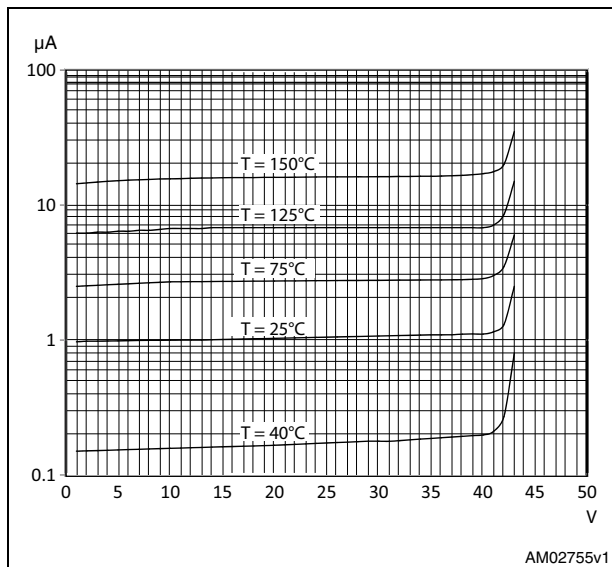
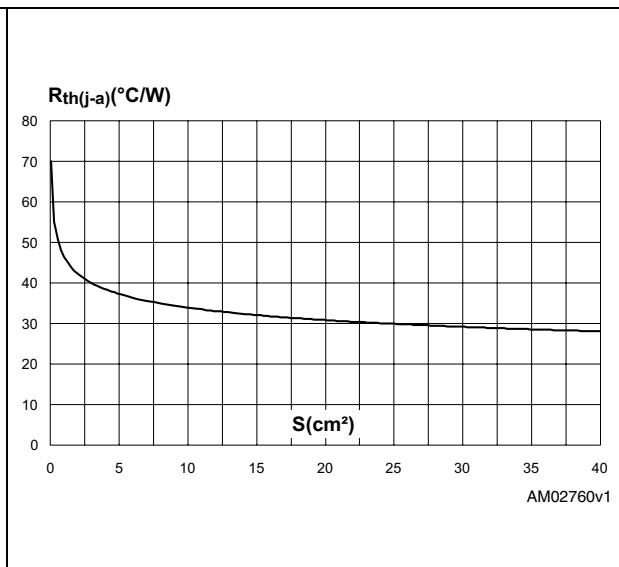

Figure 4. Thermal resistance junction-to-ambient vs copper surface under tab (1)



1. Epoxy printed board FR4,  $\text{Cu} = 35 \mu\text{m}$

Figure 5. Average forward power dissipation vs average forward current @ 25°C of ambient temperature

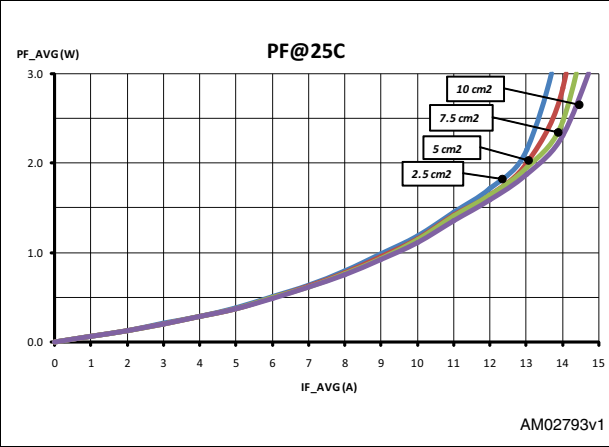

Figure 6. Average forward power dissipation vs average forward current @ 75°C of ambient temperature

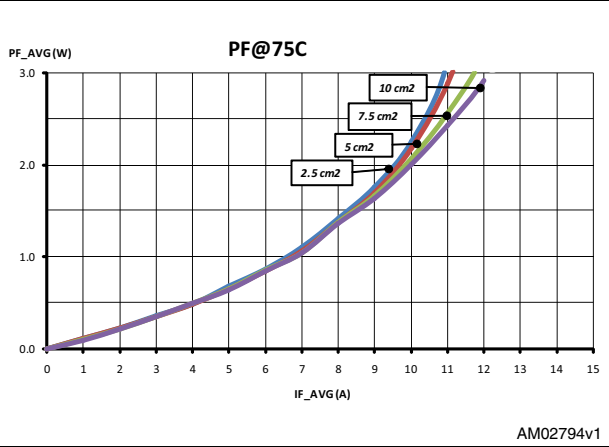
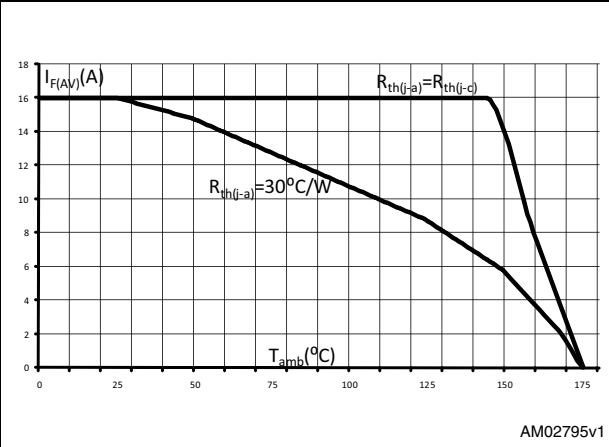

Figure 7. Average current versus ambient temperature



## 4 Package mechanical data

In order to meet environmental requirements, ST offers these devices in different grades of ECOPACK<sup>®</sup> packages, depending on their level of environmental compliance. ECOPACK<sup>®</sup> specifications, grade definitions and product status are available at: [www.st.com](http://www.st.com). ECOPACK<sup>®</sup> is an ST trademark.

**Table 5. TO-220 type A mechanical data**

Dim.	mm		
	Min.	Typ.	Max.
A	4.40		4.60
b	0.61		0.88
b1	1.14		1.70
c	0.48		0.70
D	15.25		15.75
D1		1.27	
E1	0		10.40
e	2.40		2.70
e1	4.95		5.15
F	1.23		1.32
H1	6.20		6.60
J1	2.40		2.72
L1	3		14
L1	3.50		3.93
L20		16.40	
L30		28.90	
ØP	3.75		3.85
Q	2.65		2.95

Figure 8. TO-220 type A drawing

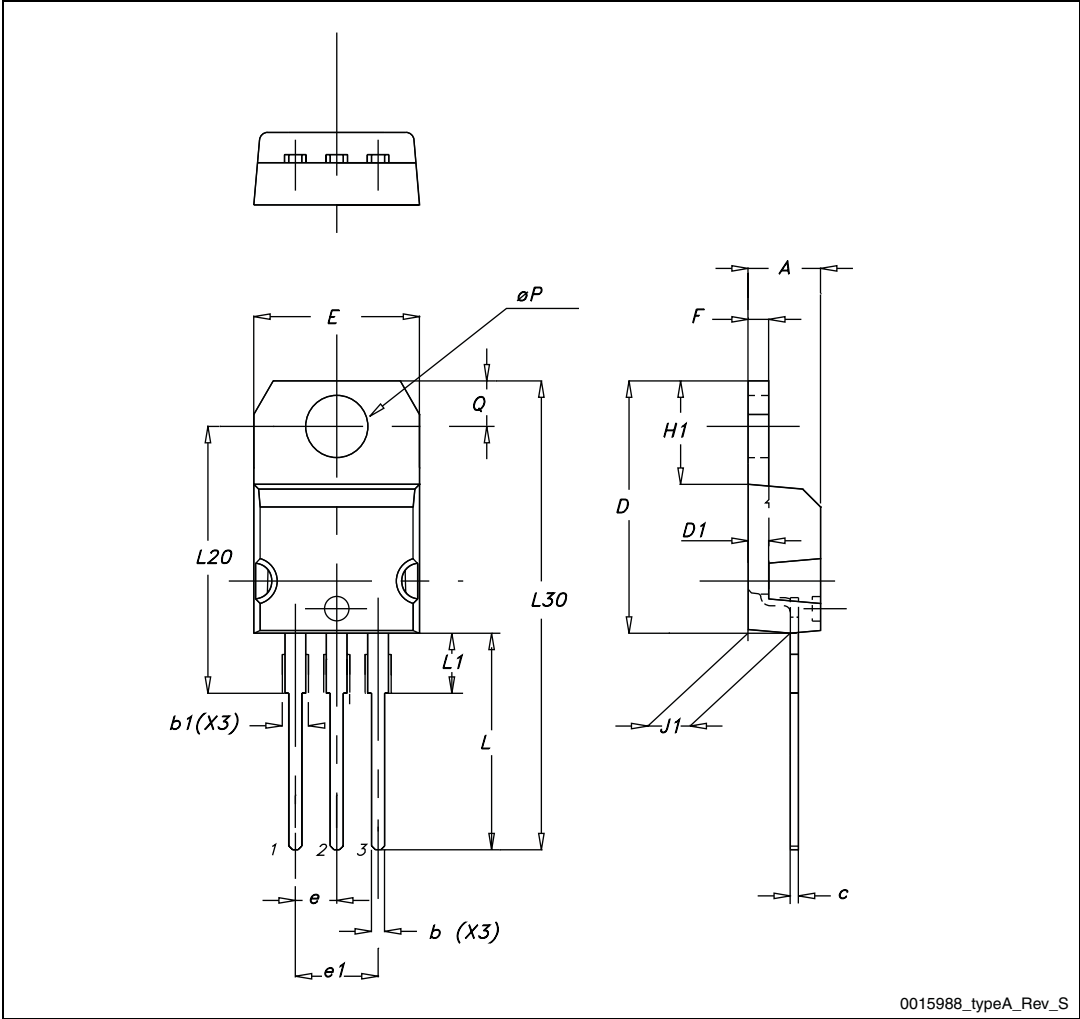

0015988\_typeA\_Rev\_S



Table 6. D<sup>2</sup>PAK (TO-263) mechanical data

Dim.	mm		
	Min.	Typ.	Max.
A	4.40		4.60
A1	0.03		0.23
b	0.70		0.93
b2	1.14		1.70
c	0.45		0.60
c2	1.23		1.36
D	8.95		9.35
D1	7.50		
E1	0		10.40
E1	8.50		
e2		.54	
e1	4.88		5.28
H1	5		15.85
J1	2.49		2.69
L	2.29		2.79
L1	1.27		1.40
L2	1.30		1.75
R0		.4	
V2	0°		8°

Figure 9. D<sup>2</sup>PAK (TO-263) drawing

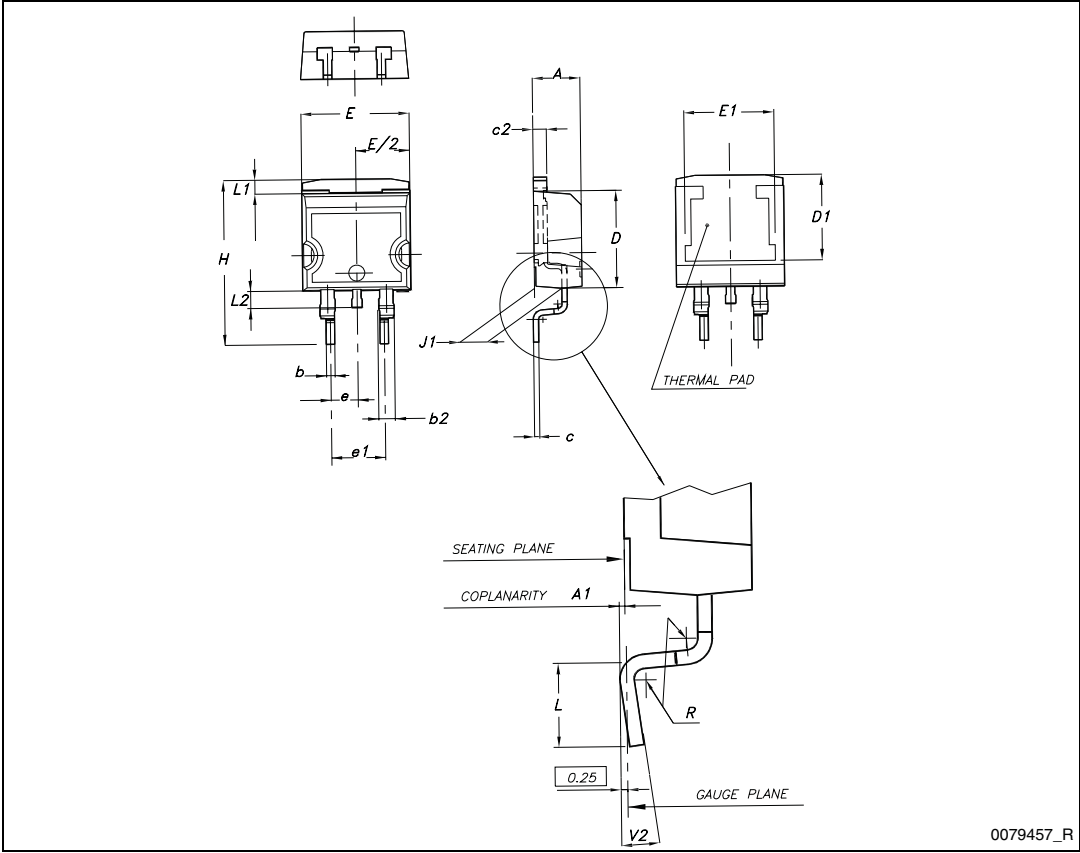

## 5 Revision history

**Table 7. Document revision history**

Date	Revision	Changes
30-Mar-2011	1	Initial release
14-Jun-2011	2	<ul style="list-style-type: none"><li>– Added D<sup>2</sup>PAK package</li><li>– Document status promoted from preliminary data to full datasheet</li><li>– Part number in title changed to SPV1001</li><li>– Minor text changes</li></ul>
11-Nov-2011	3	Updated <a href="#">Figure 3</a>

**Please Read Carefully:**

Information in this document is provided solely in connection with ST products. STMicroelectronics NV and its subsidiaries ("ST") reserve the right to make changes, corrections, modifications or improvements, to this document, and the products and services described herein at any time, without notice.

All ST products are sold pursuant to ST's terms and conditions of sale.

Purchasers are solely responsible for the choice, selection and use of the ST products and services described herein, and ST assumes no liability whatsoever relating to the choice, selection or use of the ST products and services described herein.

No license, express or implied, by estoppel or otherwise, to any intellectual property rights is granted under this document. If any part of this document refers to any third party products or services it shall not be deemed a license grant by ST for the use of such third party products or services, or any intellectual property contained therein or considered as a warranty covering the use in any manner whatsoever of such third party products or services or any intellectual property contained therein.

**UNLESS OTHERWISE SET FORTH IN ST'S TERMS AND CONDITIONS OF SALE ST DISCLAIMS ANY EXPRESS OR IMPLIED WARRANTY WITH RESPECT TO THE USE AND/OR SALE OF ST PRODUCTS INCLUDING WITHOUT LIMITATION IMPLIED WARRANTIES OF MERCHANTABILITY, FITNESS FOR A PARTICULAR PURPOSE (AND THEIR EQUIVALENTS UNDER THE LAWS OF ANY JURISDICTION), OR INFRINGEMENT OF ANY PATENT, COPYRIGHT OR OTHER INTELLECTUAL PROPERTY RIGHT.**

**UNLESS EXPRESSLY APPROVED IN WRITING BY TWO AUTHORIZED ST REPRESENTATIVES, ST PRODUCTS ARE NOT RECOMMENDED, AUTHORIZED OR WARRANTED FOR USE IN MILITARY, AIR CRAFT, SPACE, LIFE SAVING, OR LIFE SUSTAINING APPLICATIONS, NOR IN PRODUCTS OR SYSTEMS WHERE FAILURE OR MALFUNCTION MAY RESULT IN PERSONAL INJURY, DEATH, OR SEVERE PROPERTY OR ENVIRONMENTAL DAMAGE. ST PRODUCTS WHICH ARE NOT SPECIFIED AS "AUTOMOTIVE GRADE" MAY ONLY BE USED IN AUTOMOTIVE APPLICATIONS AT USER'S OWN RISK.**

Resale of ST products with provisions different from the statements and/or technical features set forth in this document shall immediately void any warranty granted by ST for the ST product or service described herein and shall not create or extend in any manner whatsoever, any liability of ST.

ST and the ST logo are trademarks or registered trademarks of ST in various countries.

Information in this document supersedes and replaces all information previously supplied.

The ST logo is a registered trademark of STMicroelectronics. All other names are the property of their respective owners.

© 2011 STMicroelectronics - All rights reserved

STMicroelectronics group of companies

Australia - Belgium - Brazil - Canada - China - Czech Republic - Finland - France - Germany - Hong Kong - India - Israel - Italy - Japan - Malaysia - Malta - Morocco - Philippines - Singapore - Spain - Sweden - Switzerland - United Kingdom - United States of America

[www.st.com](http://www.st.com)