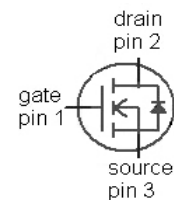
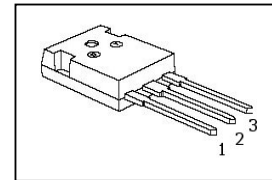

CoolMOS™ Power Transistor
Features

- New revolutionary high voltage technology
- Intrinsic fast-recovery body diode
- Extremely low reverse recovery charge
- Ultra low gate charge
- Extreme dv/dt rated
- High peak current capability
- Periodic avalanche rated
- Qualified according to JEDEC¹⁾ for target applications
- Pb-free lead plating; RoHS compliant

Product Summary

| | | |
|------------------|-------|----------|
| V_{DS} | 600 | V |
| $R_{DS(on),max}$ | 0.083 | Ω |
| I_D | 46 | A |

PG-TO247

| Type | Package | Ordering Code | Marking |
|-------------|----------|---------------|----------|
| SPW47N60CFD | PG-TO247 | Q67045A5051 | 47N60CFD |

Maximum ratings, at $T_j=25\text{ °C}$, unless otherwise specified

| Parameter | Symbol | Conditions | Value | Unit |
|---|----------------|--|-------------|--------------------|
| Continuous drain current | I_D | $T_C=25\text{ °C}$ | 46 | A |
| | | $T_C=100\text{ °C}$ | 29 | |
| Pulsed drain current ¹⁾ | $I_{D,pulse}$ | $T_C=25\text{ °C}$ | 115 | |
| Avalanche energy, single pulse | E_{AS} | $I_D=10\text{ A}$, $V_{DD}=50\text{ V}$ | 1800 | mJ |
| Avalanche energy, repetitive t_{AR} ^{2),3)} | E_{AR} | $I_D=20\text{ A}$, $V_{DD}=50\text{ V}$ | 1 | |
| Avalanche current, repetitive t_{AR} ^{2),3)} | I_{AR} | | 20 | A |
| Drain source voltage slope | dv/dt | $I_D=46\text{ A}$, $V_{DS}=480\text{ V}$, $T_j=125\text{ °C}$ | 80 | V/ns |
| Reverse diode dv/dt | dv/dt | $I_S=46\text{ A}$, $V_{DS}=480\text{ V}$, $T_j=125\text{ °C}$ | 40 | V/ns |
| Maximum diode commutation speed | di/dt | $T_j=125\text{ °C}$ | 600 | A/ μ s |
| Gate source voltage | V_{GS} | static | ± 20 | V |
| | | AC ($f>1\text{ Hz}$) | ± 30 | |
| Power dissipation | P_{tot} | $T_C=25\text{ °C}$ | 417 | W |
| Operating and storage temperature | T_j, T_{stg} | | -55 ... 150 | $^{\circ}\text{C}$ |

| Parameter | Symbol | Conditions | Values | | | Unit |
|-----------|--------|------------|--------|------|------|------|
| | | | min. | typ. | max. | |

Thermal characteristics

| | | | | | | |
|--|------------|--|---|---|-----|-----|
| Thermal resistance, junction - case | R_{thJC} | | - | - | 0.3 | K/W |
| Thermal resistance, junction - ambient | R_{thJA} | leaded | - | - | 62 | |
| Soldering temperature, wave soldering | T_{sold} | 1.6 mm (0.063 in.) from case for 10 s | - | - | 260 | °C |

Electrical characteristics, at $T_j=25\text{ °C}$, unless otherwise specified
Static characteristics

| | | | | | | |
|----------------------------------|---------------|---|-----|------|-------|---------------|
| Drain-source breakdown voltage | $V_{(BR)DSS}$ | $V_{GS}=0\text{ V}, I_D=250\text{ }\mu\text{A}$ | 600 | - | - | V |
| Avalanche breakdown voltage | $V_{(BR)DS}$ | $V_{GS}=0\text{ V}, I_D=46\text{ A}$ | - | 700 | - | |
| Gate threshold voltage | $V_{GS(th)}$ | $V_{DS}=V_{GS}, I_D=2.9\text{ mA}$ | 3 | 4 | 5 | |
| Zero gate voltage drain current | I_{DSS} | $V_{DS}=600\text{ V}, V_{GS}=0\text{ V}, T_j=25\text{ °C}$ | - | 6 | - | μA |
| | | $V_{DS}=600\text{ V}, V_{GS}=0\text{ V}, T_j=150\text{ °C}$ | - | 5000 | - | |
| Gate-source leakage current | I_{GSS} | $V_{GS}=20\text{ V}, V_{DS}=0\text{ V}$ | - | - | 100 | nA |
| Drain-source on-state resistance | $R_{DS(on)}$ | $V_{GS}=10\text{ V}, I_D=29\text{ A}, T_j=25\text{ °C}$ | - | 0.07 | 0.083 | Ω |
| | | $V_{GS}=10\text{ V}, I_D=29\text{ A}, T_j=150\text{ °C}$ | - | 0.15 | - | |
| Gate resistance | R_G | $f=1\text{ MHz}$, open drain | - | 0.62 | - | |
| Transconductance | g_{fs} | $ V_{DS} >2 I_D R_{DS(on)max}, I_D=29\text{ A}$ | - | 30 | - | S |

| Parameter | Symbol | Conditions | Values | | | Unit |
|-----------|--------|------------|--------|------|------|------|
| | | | min. | typ. | max. | |

Dynamic characteristics

| | | | | | | |
|--|--------------|---|---|------|---|----|
| Input capacitance | C_{iss} | $V_{GS}=0\text{ V}, V_{DS}=25\text{ V}, f=1\text{ MHz}$ | - | 7700 | - | pF |
| Output capacitance | C_{oss} | | - | 2200 | - | |
| Reverse transfer capacitance | C_{rss} | | - | 77 | - | |
| Effective output capacitance, energy related ⁴⁾ | $C_{o(er)}$ | $V_{GS}=0\text{ V}, V_{DS}=0\text{ V}$ to 480 V | - | 245 | - | |
| Effective output capacitance, time related ⁵⁾ | $C_{o(tr)}$ | | - | 453 | - | |
| Turn-on delay time | $t_{d(on)}$ | $V_{DD}=400\text{ V}, V_{GS}=10\text{ V}, I_D=46\text{ A}, R_G=3.3\ \Omega$ | - | 30 | - | ns |
| Rise time | t_r | | - | 30 | - | |
| Turn-off delay time | $t_{d(off)}$ | | - | 100 | - | |
| Fall time | t_f | | - | 15 | - | |

Gate Charge Characteristics

| | | | | | | |
|-----------------------|---------------|--|---|-----|-----|----|
| Gate to source charge | Q_{gs} | $V_{DD}=480\text{ V}, I_D=46\text{ A}, V_{GS}=0\text{ to }10\text{ V}$ | - | 54 | - | nC |
| Gate to drain charge | Q_{gd} | | - | 130 | - | |
| Gate charge total | Q_g | | - | 248 | 322 | |
| Gate plateau voltage | $V_{plateau}$ | | - | 7.1 | - | |

¹⁾ J-STD20 and JESD22

²⁾ Pulse width t_p limited by $T_{j,max}$
³⁾ Repetitive avalanche causes additional power losses that can be calculated as $P_{AV}=E_{AR} \cdot f$.

⁴⁾ $C_{o(er)}$ is a fixed capacitance that gives the same stored energy as C_{oss} while V_{DS} is rising from 0 to 80% V_{DSS} .

⁵⁾ $C_{o(tr)}$ is a fixed capacitance that gives the same charging time as C_{oss} while V_{DS} is rising from 0 to 80% V_{DSS} .

| Parameter | Symbol | Conditions | Values | | | Unit |
|-----------|--------|------------|--------|------|------|------|
| | | | min. | typ. | max. | |

Reverse Diode

| | | | | | | |
|----------------------------------|---------------|--|---|-----|-----|---------------|
| Diode continuous forward current | I_S | $T_C=25\text{ }^\circ\text{C}$ | - | - | 46 | A |
| Diode pulse current | $I_{S,pulse}$ | | - | - | 115 | |
| Diode forward voltage | V_{SD} | $V_{GS}=0\text{ V}, I_F=46\text{ A}, T_j=25\text{ }^\circ\text{C}$ | - | 1.0 | 1.2 | V |
| Reverse recovery time | t_{rr} | $V_R=480\text{ V}, I_F=I_S, di_F/dt=100\text{ A}/\mu\text{s}$ | - | 210 | - | ns |
| Reverse recovery charge | Q_{rr} | | - | 2 | - | μC |
| Peak reverse recovery current | I_{rrm} | | - | 18 | - | A |

Typical Transient Thermal Characteristics

| Symbol | Value | Unit | Symbol | Value | Unit |
|-----------|---------|------|-----------|-------------------|------|
| | typ. | | | typ. | |
| R_{th1} | 0.00289 | K/W | C_{th1} | 0.000564 | Ws/K |
| R_{th2} | 0.00399 | | C_{th2} | 0.0034 | |
| R_{th3} | 0.0224 | | C_{th3} | 0.0048 | |
| R_{th4} | 0.0421 | | C_{th4} | 0.0273 | |
| R_{th5} | 0.0619 | | C_{th5} | 0.149 | |
| | | | C_{th6} | 4.4 ⁵⁾ | |

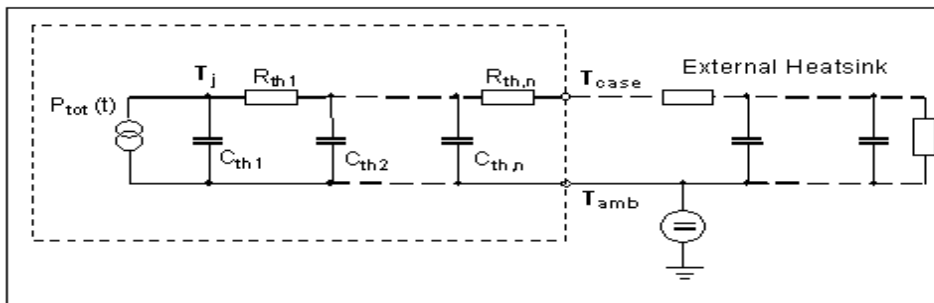

⁵⁾ C_{th6} models the additional heat capacitance of the package in case of non-ideal cooling. It is not needed if $R_{thCA}=0\text{ K/W}$.

1 Power dissipation

$P_{tot}=f(T_C)$

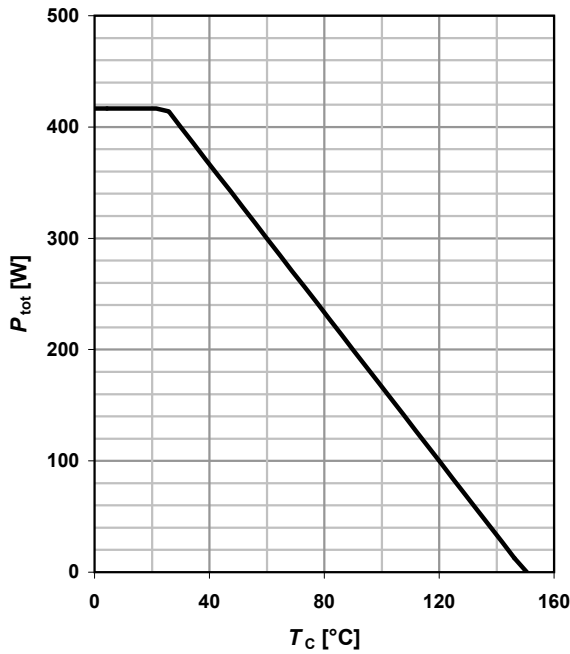

www.DataSheet4U.com

2 Safe operating area

$I_D=f(V_{DS}); T_C=25\text{ °C}; D=0$

parameter: t_p

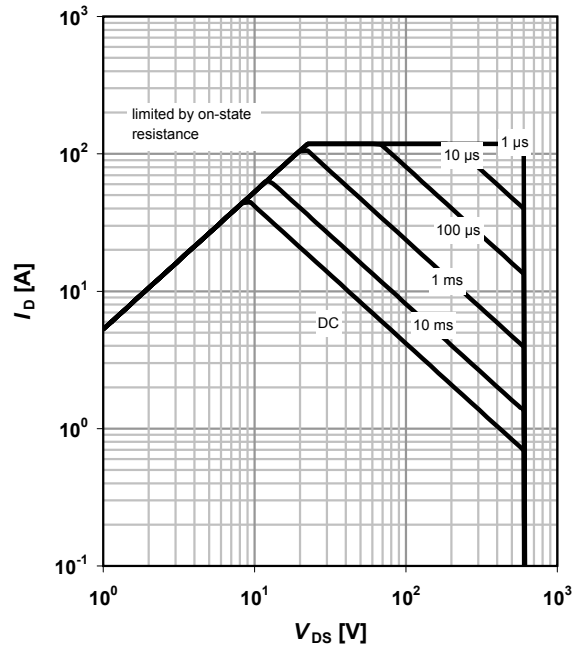

3 Max. transient thermal impedance

$I_D=f(V_{DS}); T_J=25\text{ °C}$

parameter: $D=t_p/T$

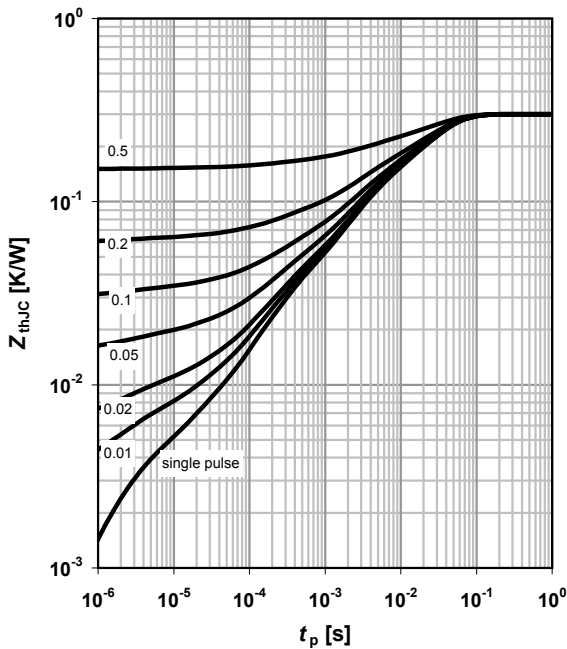

4 Typ. output characteristics

$I_D=f(V_{DS}); T_J=25\text{ °C}$

parameter: V_{GS}

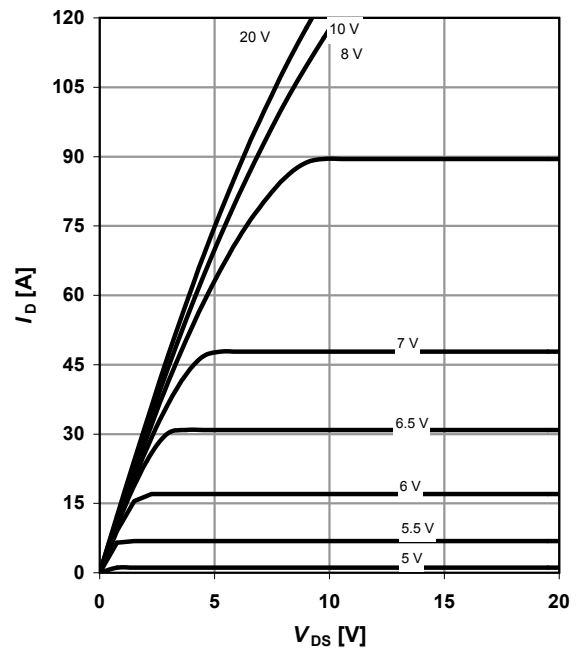

5 Typ. output characteristics

$I_D = f(V_{DS}); T_j = 150\text{ }^\circ\text{C}$

parameter: V_{GS}

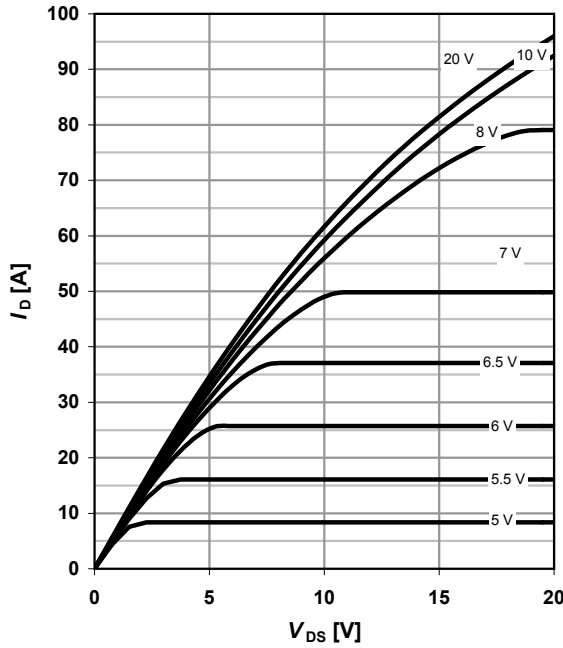

6 Typ. drain-source on-state resistance

$R_{DS(on)} = f(I_D); T_j = 150\text{ }^\circ\text{C}$

parameter: V_{GS}

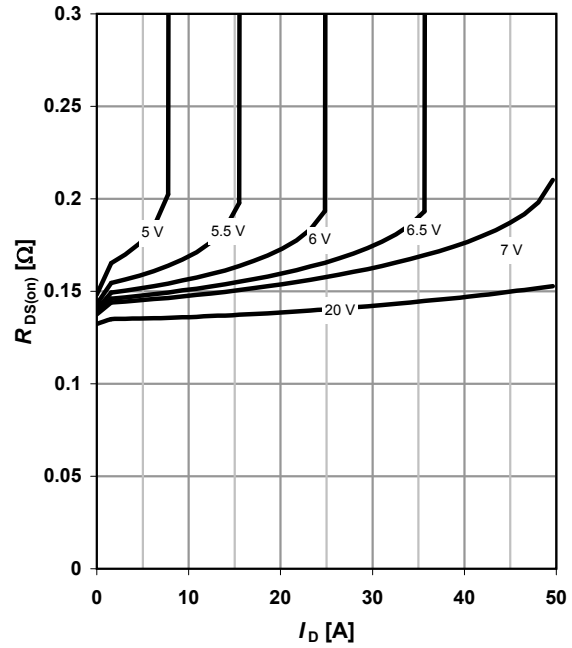

7 Drain-source on-state resistance

$R_{DS(on)} = f(T_j); I_D = 30\text{ A}; V_{GS} = 10\text{ V}$

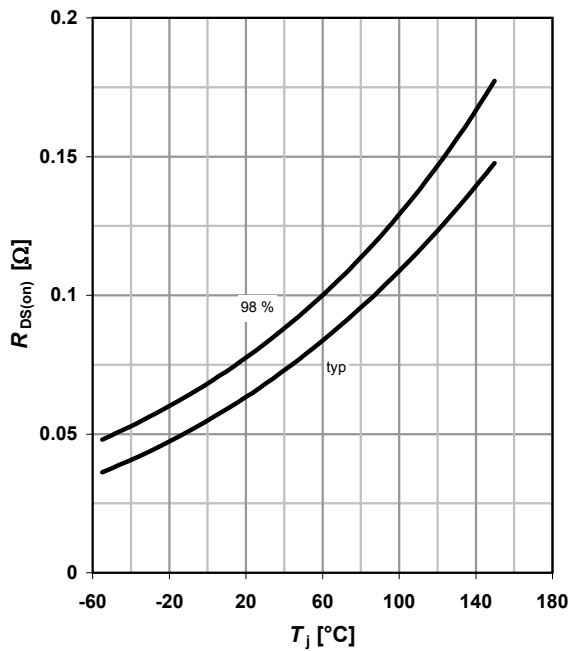

8 Typ. transfer characteristics

$I_D = f(V_{GS}); |V_{DS}| > 2|I_D|R_{DS(on)max}$

parameter: T_j

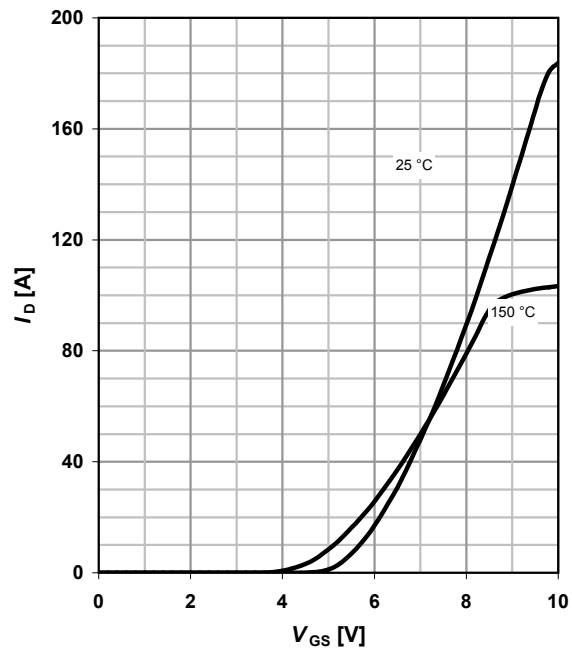

9 Typ. gate charge

$V_{GS}=f(Q_{gate}); I_D=47\text{ A pulsed}$

parameter: V_{DD}

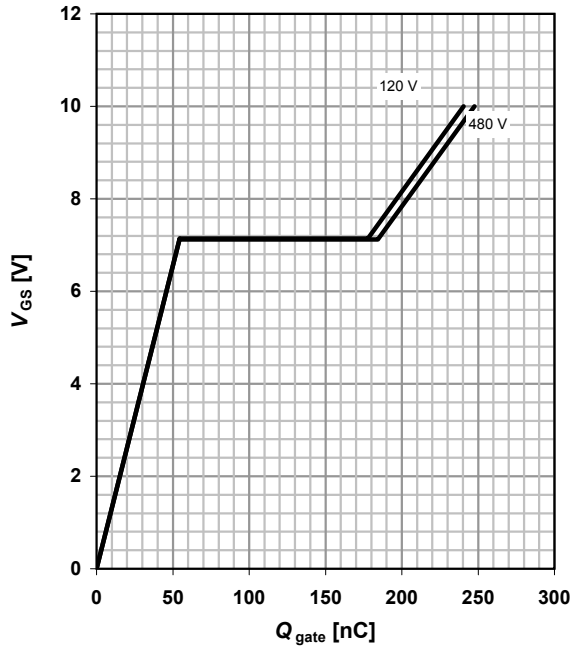

10 Forward characteristics of reverse diode

$I_F=f(V_{SD})$

parameter: T_j

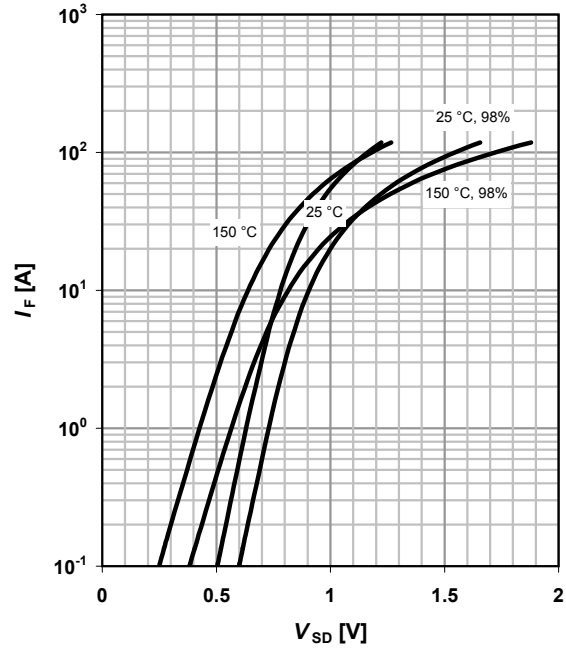

11 Avalanche SOA

$I_{AR}=f(t_{AR})$

parameter: $T_{j(start)}$

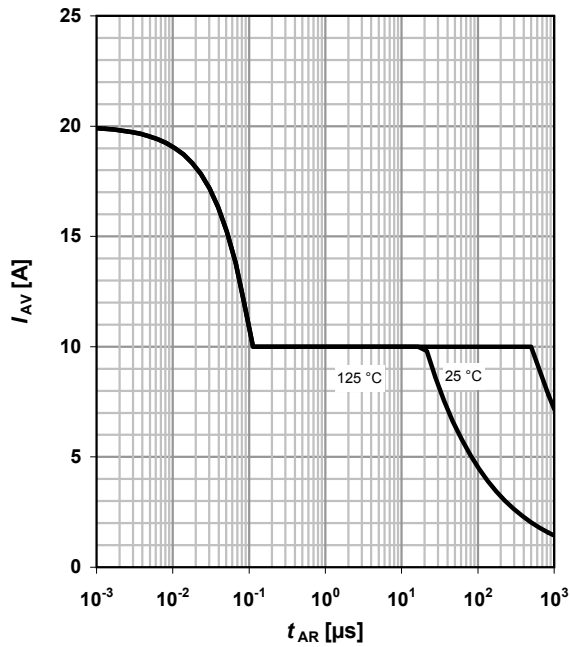

12 Avalanche energy

$E_{AS}=f(T_j); I_D=10\text{ A}; V_{DD}=50\text{ V}$

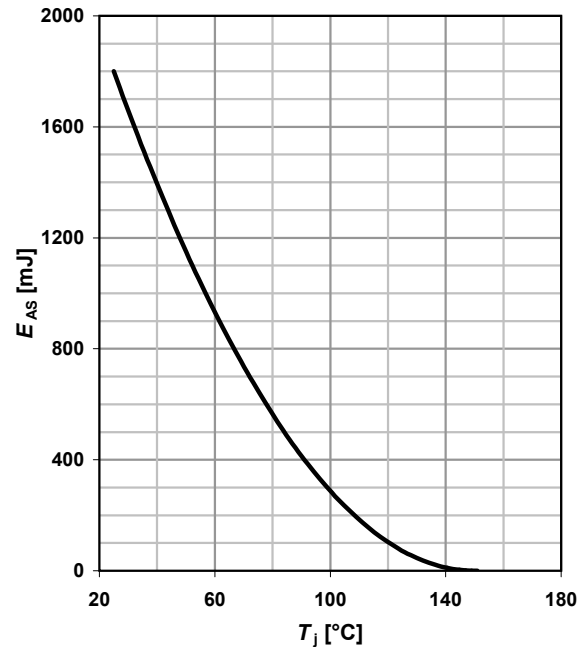

13 Drain-source breakdown voltage

$V_{BR(DSS)} = f(T_j); I_D = 15 \text{ mA}$

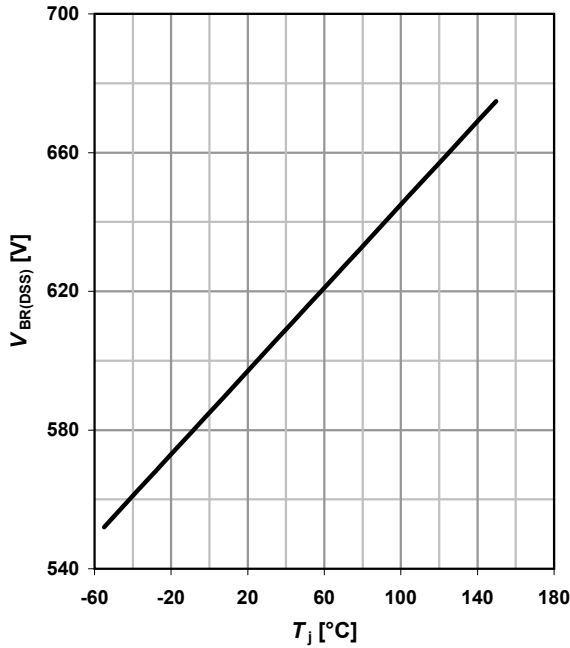

14 Typ. capacitances

$C = f(V_{DS}); V_{GS} = 0 \text{ V}; f = 1 \text{ MHz}$

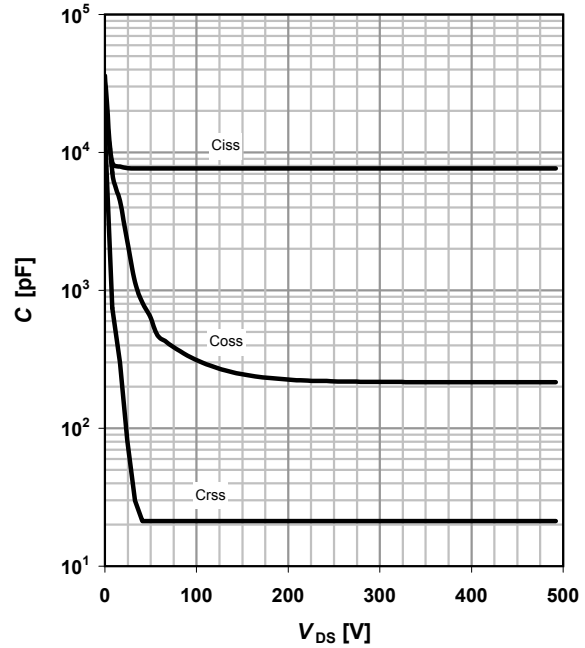

15 Typ. C_{oss} stored energy

$E_{oss} = f(V_{DS})$

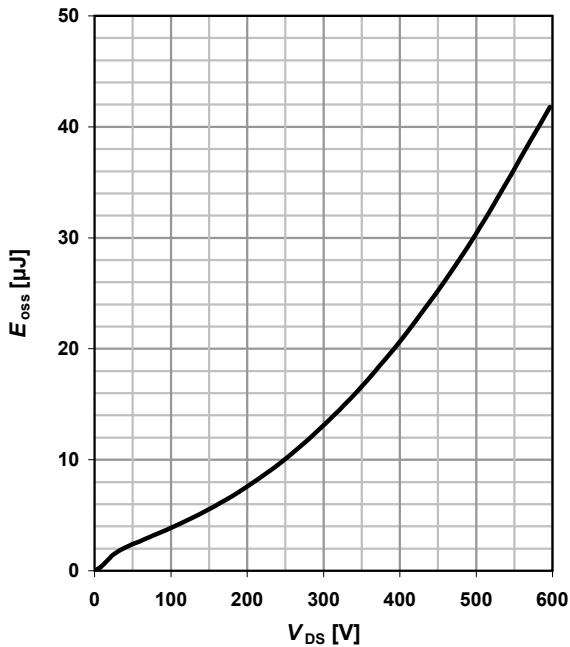

16 Typ. reverse recovery charge

$Q_{rr} = f(T_j); I_S = 47 \text{ A}; di/dt = 100 \text{ A/μs}$

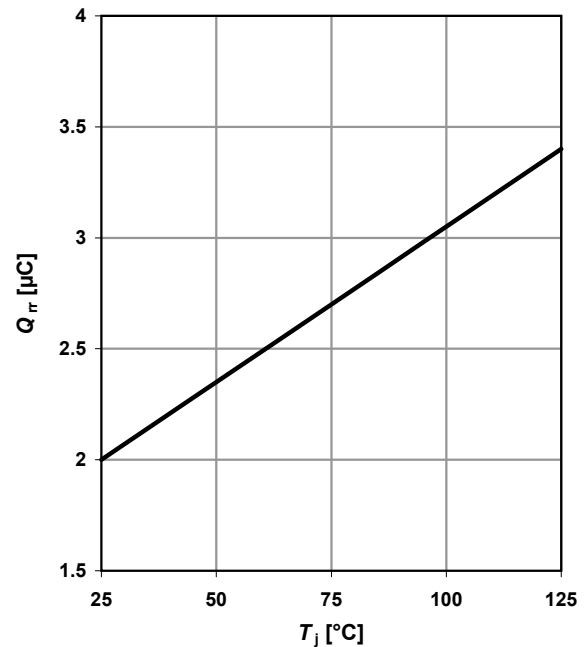

17 Typ. reverse recovery charge

$Q_{rr}=f(I_S); di/dt=100\text{ A}/\mu\text{s}$

parameter: T_j

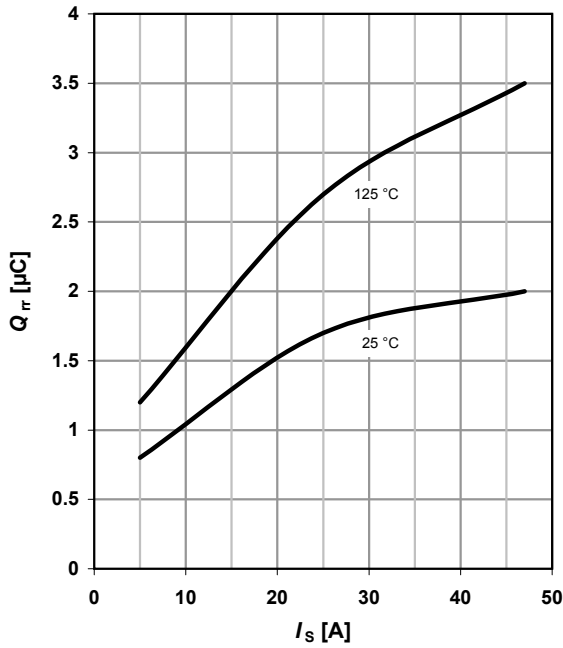

18 Typ. reverse recovery charge

$Q_{rr}=f(di/dt); I_S=47\text{ A}$

parameter: T_j

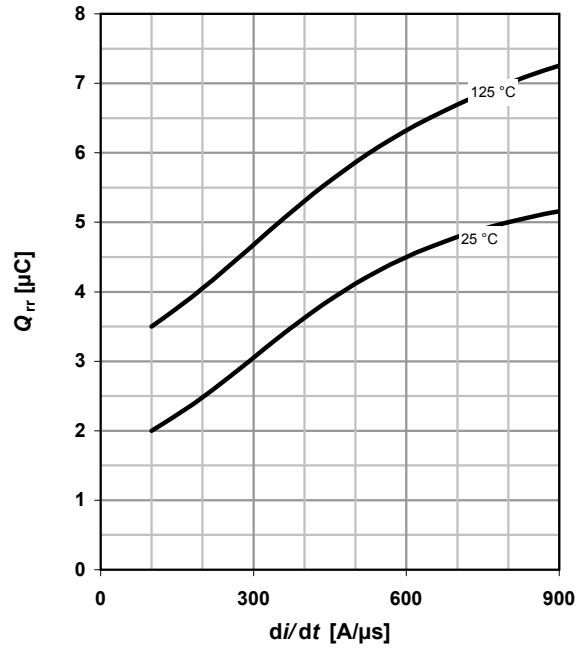

www.DataSheet4U.com

Definition of diode switching characteristics

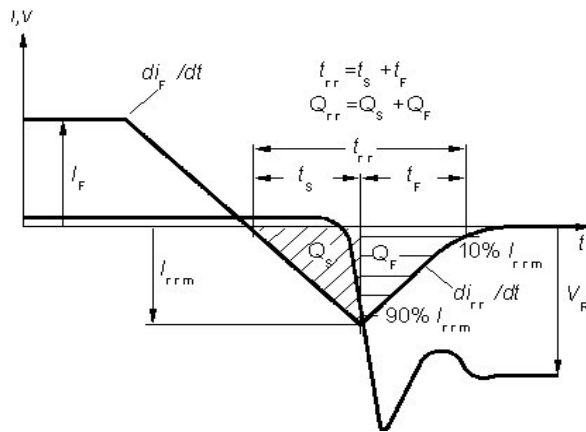

www.DataSheet4U.com

PG-TO-247-3-1

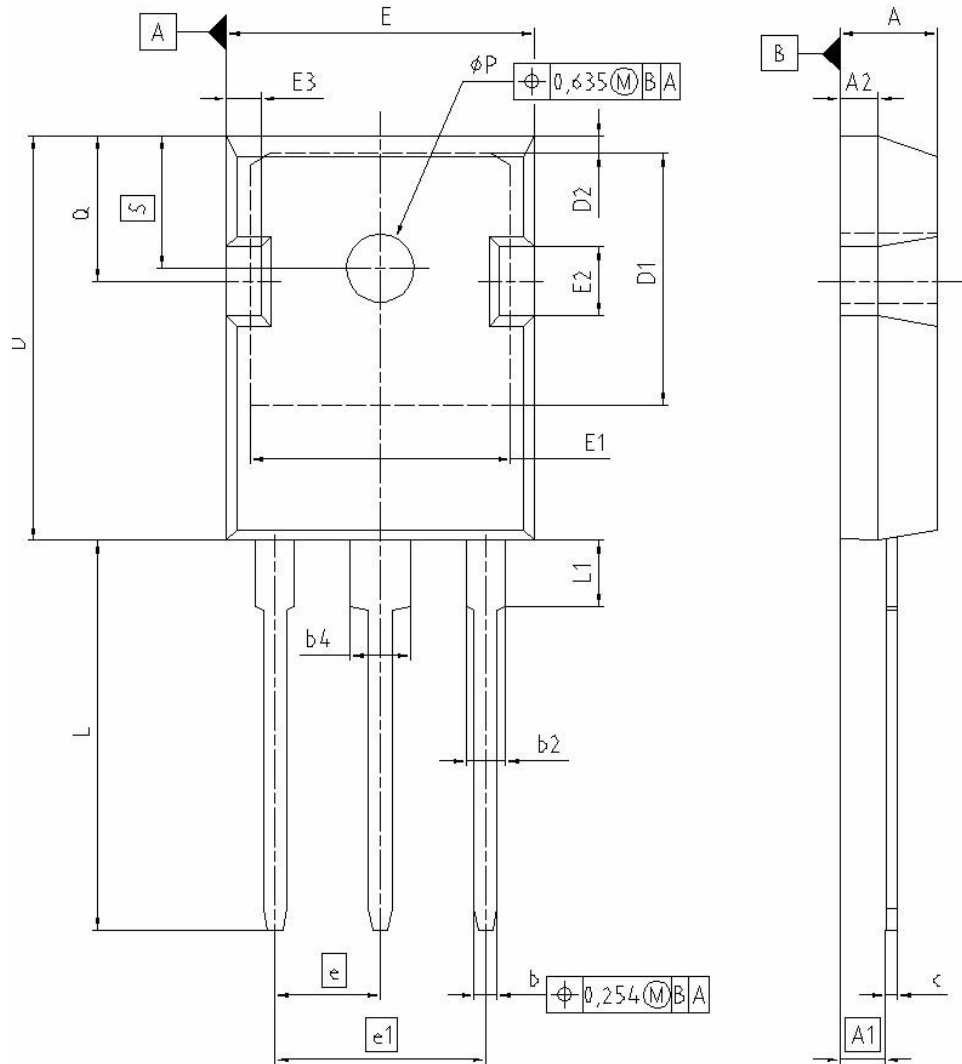

| DIM | MILLIMETERS | | INCHES | |
|-------|-------------|--------|--------|-------|
| | MIN | MAX | MIN | MAX |
| A | 4.903 | 5.157 | 0.193 | 0.203 |
| A1 | 2.273 | 2.527 | 0.092 | 0.096 |
| A2 | 1.853 | 2.107 | 0.075 | 0.081 |
| b | 1.073 | 1.327 | 0.047 | 0.052 |
| b2 | 1.903 | 2.386 | 0.075 | 0.094 |
| b4 | 2.870 | 3.454 | 0.113 | 0.136 |
| c | 0.549 | 0.752 | 0.024 | 0.030 |
| D | 20.823 | 21.077 | 0.820 | 0.830 |
| D1 | 17.323 | 17.831 | 0.682 | 0.702 |
| D2 | 1.063 | 1.317 | 0.042 | 0.052 |
| E | 15.773 | 16.027 | 0.621 | 0.631 |
| E1 | 13.893 | 14.147 | 0.547 | 0.557 |
| E2 | 3.683 | 3.937 | 0.145 | 0.155 |
| E3 | 1.683 | 1.937 | 0.066 | 0.076 |
| e | 5.450 | | 0.215 | |
| e1 | 10.900 | | 0.430 | |
| N | 3 | | 3 | |
| L | 20.053 | 20.307 | 0.789 | 0.799 |
| L1 | 4.168 | 4.472 | 0.164 | 0.176 |
| phi P | 3.559 | 3.661 | 0.140 | 0.144 |
| Q | 5.493 | 5.747 | 0.216 | 0.226 |
| S | 6.043 | 6.297 | 0.238 | 0.248 |

REFERENCE
JEDEC TO247-AD

SCALE
0 5 5 7.5mm

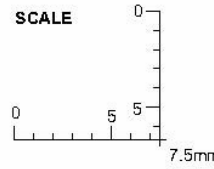
EUROPEAN PROJECTION

ISSUE DATE
28-06-2005

FILE
TO247_1

Published by
Infineon Technologies AG
Bereich Kommunikation
St.-Martin-Straße 53
D-81541 München
© Infineon Technologies AG 1999
All Rights Reserved.

Attention please!

The information herein is given to describe certain components and shall not be considered as warranted characteristics.

Terms of delivery and rights to technical change reserved.

We hereby disclaim any and all warranties, including but not limited to warranties of non-infringement, regarding circuits, descriptions and charts stated herein.

Infineon Technologies is an approved CECC manufacturer.

Information

For further information on technology, delivery terms and conditions and prices, please contact your nearest Infineon Technologies office in Germany or our Infineon Technologies representatives worldwide (see address list).

Warnings

Due to technical requirements, components may contain dangerous substances.
For information on the types in question, please contact your nearest Infineon Technologies office.

Infineon Technologies' components may only be used in life-support devices or systems with the expressed written approval of Infineon Technologies if a failure of such components can reasonably be expected to cause the failure of that life-support device or system, or to affect the safety or effectiveness of that device or system. Life support devices or systems are intended to be implanted in the human body, or to support and/or maintain and sustain and/or protect human life. If they fail, it is reasonable to assume that the health of the user or other persons may be endangered.