



SPX1587

3A Low Dropout Voltage Regulator Adjustable & Fixed Output, Fast Response

FEATURES

- Adjustable Output Down To 1.2V
- Fixed Output Voltages 1.5, 2.5, 3.3, 5.0V
- Output Current Of 3A
- Low Dropout Voltage 1.1V Typ.
- Extremely Tight Load And Line Regulation
- Current & Thermal Limiting
- Standard 3-Terminal Low Cost TO-220, TO-263 & TO-252
- Similar To Industry Standard LT1085/LT1585

APPLICATIONS

- Powering VGA & Sound Card
- Power PC™ Supplies
- SMPS Post-Regulator
- High Efficiency “Green” Computer Systems
- High Efficiency Linear Power Supplies
- Portable Instrumentation
- Constant Current Regulators
- Adjustable Power Supplies
- Battery charger

PRODUCT DESCRIPTION

The SPX1587 is a low power 3A adjustable and fixed voltage regulator that is very easy to use. It requires only 2 external resistors to set the output voltage for adjustable version. The SPX1587 are designed for low voltage applications that offers lower dropout voltage and faster transient response. This device is an excellent choice for use in powering low voltage microprocessor that require a lower dropout, faster transient response to regulate from +2.5V to 3.8V supplies and as a post regulator for switching supplies applications. The SPX1587 features low dropout of a maximum 1.2 volts.

The SPX1587 offers over current limit and full protection against reversed input polarity, reversed load insertion, and positive and negative transient voltage. On-Chip trimming adjusts the reference voltage to 1%. The I_Q of this device flows into the load, which increases efficiency.

The SPX1587 are offered in a 3-pin TO-220, TO-263 & TO-252 packages compatible with other 3 terminal regulators. For a 5A low dropout regulator refer to the SPX1585 data sheet.

PIN CONNECTIONS

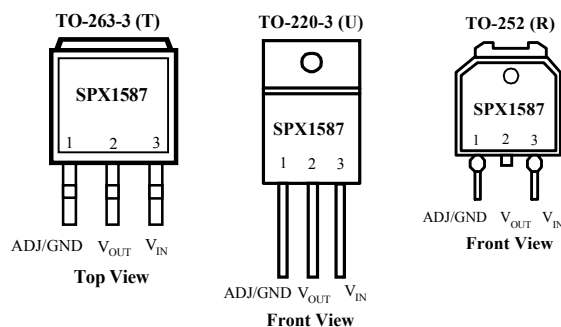

ABSOLUTE MAXIMUM RATINGS

Lead Temp. (Soldering, 10 Seconds) 300°C
 Storage Temperature Range -65° to +150°C
 Operating Junction Temperature Range
 SPX1587 Control Section..... -45°C +125°C
 SPX1587 Power Transistor.....-45°C +150°C

Maximum Input Voltage 10V
 Input to Output Voltage Differential Max 8.8V

ELECTRICAL CHARACTERISTICS (NOTE 1) at $I_{OUT} = 10\text{mA}$, $T_A = 25^\circ\text{C}$, unless otherwise specified.

PARAMETER	CONDITIONS	Typ	SPX1587A		SPX1587		Units
			Min	Max	Min	Max	
1.5V Version							
Output Voltage (Note 2)	SPX1587-1.5V, $0 \leq I_{OUT} \leq 3\text{A}$, $2.75\text{V} \leq V_{IN} \leq 10\text{V}$	1.5	1.485	1.515	1.470	1.530	V
		1.5	1.470	1.530	1.455	1.545	
2.5V Version							
Output Voltage (Note 2)	SPX1587-2.5V, $0 \leq I_{OUT} \leq 3\text{A}$, $4.0\text{V} \leq V_{IN} \leq 10\text{V}$	2.5	2.475	2.525	2.450	2.550	V
		2.5	2.450	2.550	2.425	2.575	
3.3V Version							
Output Voltage (Note 2)	SPX1587-3.3V, $0 \leq I_{OUT} \leq 3\text{A}$, $4.75\text{V} \leq V_{IN} \leq 10\text{V}$	3.3	3.270	3.330	3.230	3.370	V
		3.3	3.240	3.360	3.201	3.399	
5.0V Version							
Output Voltage (Note 2)	SPX1587-5.0V, $0 \leq I_{OUT} \leq 3\text{A}$, $6.5\text{V} \leq V_{IN} \leq 10\text{V}$	5.0	4.95	5.05	4.900	5.100	V
		5.0	4.90	5.10	4.850	5.150	
All Voltage Options							
Reference Voltage (V_{REF})	$V_{IN} \leq 7\text{V}$, $P \leq P_{MAX}$ $1.5\text{V} \leq (V_{IN} - V_{OUT}) \leq (V_{IN} - V_{OUT})_{MAX}$, $10\text{mA} \leq I_{OUT} \leq 3\text{A}$	1.250	1.238 1.225	1.263 1.270	1.225 1.212	1.270 1.288	V
Min. Load Current (Note 3)	$1.5\text{V} \leq (V_{IN} - V_{OUT}) \leq (V_{IN} - V_{OUT})_{MAX}$	5		10		10	mA
Line Regulation ($\Delta V_{REF}(V_{IN})$)	$2.75\text{V} \leq V_{IN} \leq 7\text{V}$, $I_{OUT} = 10\text{mA}$, $T_J = 25^\circ\text{C}$ (Note 3)	0.005		0.2		0.2	%
	$V_{IN} \leq 7\text{V}$, $I_{OUT} = 0\text{mA}$, $T_J = 25^\circ\text{C}$ (Note 2)	0.005		0.2		0.2	%
Load Regulation ($\Delta V_{REF}(I_{OUT})$)	$10\text{mA} \leq I_{OUT} \leq 3\text{A}$, $(V_{IN} - V_{OUT}) = 3\text{V}$, $T_J = 25^\circ\text{C}$ (Note 3)	0.05		0.3		0.3	%
	$0 \leq I_{OUT} \leq 3\text{A}$, $V_{IN} = 7\text{V}$, $T_J = 25^\circ\text{C}$ (Note 2)	0.05		0.3		0.3	%
Dropout Voltage	$\Delta V_{REF} = 1\%$ $I_{OUT} = 3\text{A}$ $I_{OUT} \leq 3\text{A}$	1.1		1.2		1.2	V
Current Limit $I_{OUT(MAX)}$	$V_{IN} = 7\text{V}$ $1.4\text{V} \leq (V_{IN} - V_{OUT})$ (Note3)	4.0	3.2		3.2		A
Long Term Stability	$T_A = 125^\circ\text{C}$, 1000 Hrs.	0.3 (Note 2)		1		1	%
Thermal Regulation ($\Delta V_{OUT}(P_{WR})$)	$T_A = 25^\circ\text{C}$, 20 ms pulse	0.01		0.020		0.020	%/W
Temperature Stability ($\Delta V_{OUT}(T)$)		0.25					%
Output Noise, RMS	10Hz to 10kHz $T_A = 25^\circ\text{C}$	0.003					%V
Thermal Resistance	TO-220 Junction to Tab Junction to Ambient DD Package Junction to Tab Junction to Ambient			3.0 60 3.0 60		3.0 60 3.0 60	°C/W

The Bold specifications apply to the full operating temperature range.

Note 1: Changes in output voltage due to heating effects are covered under the specification for thermal regulation.

Note 2: Fixed Version Only

Note 3: Adjustable Version Only

APPLICATION HINTS

The SPX1587 incorporates protection against over-current faults, reversed load insertion, over temperature operation, and positive and negative transient voltage. However, the use of an output capacitor is required in order to improve the stability and the performances.

Stability

The output capacitor is part of the regulator's frequency compensation system. Either a 22 μ F aluminum electrolytic capacitor or a 10 μ F solid tantalum capacitor between the output terminal and ground guarantees stable operation for all operating conditions.

However, in order to minimize overshoot and undershoot, and therefore optimize the design, please refer to the section 'Ripple Rejection'.

Ripple Rejection

Ripple rejection can be improved by adding a capacitor between the ADJ pin and ground as shown in figure 6. When ADJ pin bypassing is used, the value of the output capacitor required increases to its maximum (22 μ F for an aluminum electrolytic capacitor, or 10 μ F for a solid tantalum capacitor). If the ADJ pin is not bypass, the value of the output capacitor can be lowered to 10 μ F for an electrolytic aluminum capacitor or 4.7 μ F for a solid tantalum capacitor.

However the value of the ADJ-bypass capacitor should be chosen with respect to the following equation:

$$C = 1 / (6.28 * F_R * R_1)$$

Where C = value of the capacitor in Farads (select an equal or larger standard value),

F_R = ripple frequency in Hz,

R_1 = value of resistor R_1 in Ohms.

If an ADJ-bypass capacitor is use, the amplitude of the output ripple will be independent of the output voltage. If an ADJ-bypass capacitor is not used, the output ripple will be proportional to the ratio of the output voltage to the reference voltage:

$$M = V_{OUT} / V_{REF}$$

Where M = multiplier for the ripple seen when the ADJ pin is optimally bypassed.

V_{REF} = Reference Voltage

Reducing parasitic resistance and inductance

One solution to minimize parasitic resistance and inductance is to connect in parallel capacitors. This arrangement will improve the transient response of the power supply if your system requires rapidly changing current load condition.

Thermal Consideration

Although the SPX1587 offers some limiting circuitry for overload conditions, it is necessary not to exceed the maximum junction temperature, and therefore to be careful about thermal resistance. The heat flow will follow the lowest resistance path, which is the Junction-to-case thermal resistance. In order to insure the best thermal flow of the component, a proper mounting is required. Note that the case of the device is electrically connected to the output. In case the case has to be electrically isolated, a thermally conductive spacer can be used. However do not forget to consider its contribution to thermal resistance.

Assuming:

$$V_{IN} = 10V, V_{OUT} = 5V, I_{OUT} = 1.5A, T_A = 50^{\circ}C/W,$$

$$\theta_{Heatsink Case} = 6^{\circ}C/W, \theta_{Heatsink Case} = 0.5^{\circ}C/W, \theta_{JC} = 3^{\circ}C/W$$

Power dissipation under this condition

$$P_D = (V_{IN} - V_{OUT}) * I_{OUT} = 7.5W$$

Junction Temperature

$$T_J = T_A + P_D * (\theta_{Case - HS} + \theta_{HS} + \theta_{JC})$$

For the Control Sections

$$T_J = 50 + 7.5 * (0.5 + 6) = 121.25^{\circ}C$$

$121.25^{\circ}C < T_{J(max)}$ for the Control & Power Sections.

In both case reliable operation is insured by adequate junction temperature.

Basic Adjustable Regulator

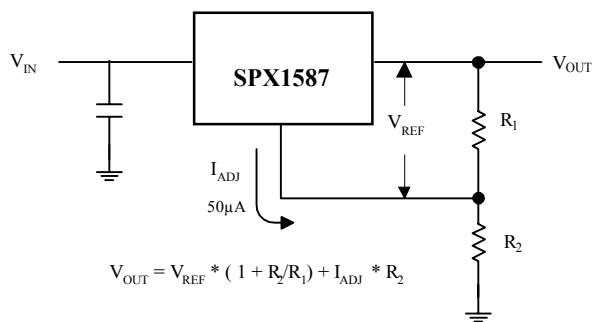

Fig.2 Basic Adjustable Regulator

Output Voltage

Consider Figure 2. The resistance R_1 generates a constant current flow, normally the specified load current of 10mA. This current will go through the resistance R_2 to set the overall output voltage. The current I_{ADJ} is very small and constant. Therefore its contribution to the overall output voltage is very small and can generally be ignored.

Load Regulation

Parasitic line resistance can degrade load regulation. In order not to affect the behavior of the regulator, it is best to connect directly the R_1 resistance from the resistor divider to the case, and not to the load. For the same reason, it is best to connect the resistor R_2 to the Negative side of the load.

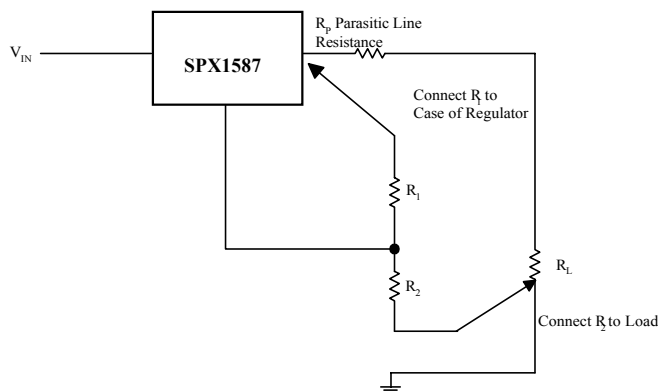
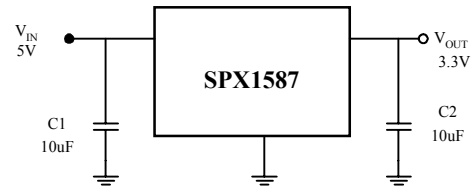

Fig.3 Basic Adjustable Regulator



Basic Fixed Regulator

Output Voltage

The fixed voltage LDO voltage regulators are simple to use regulators since the V_{OUT} is preset to the specifications. It is important however, to provide the proper output capacitance for stability and improvement. For most operating conditions a capacitance of 22µF tantalum or 100µF electrolytic will ensure stability and prevent oscillation.

TYPICAL APPLICATIONS

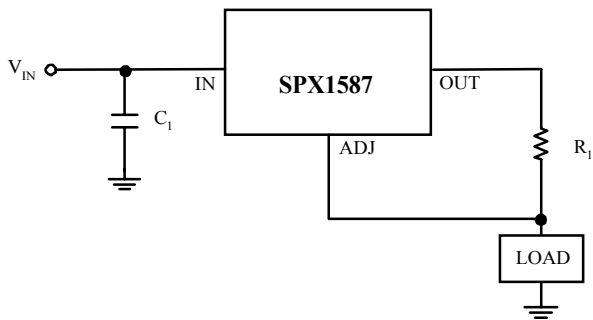

Fig. 4 3A Current output Regulator

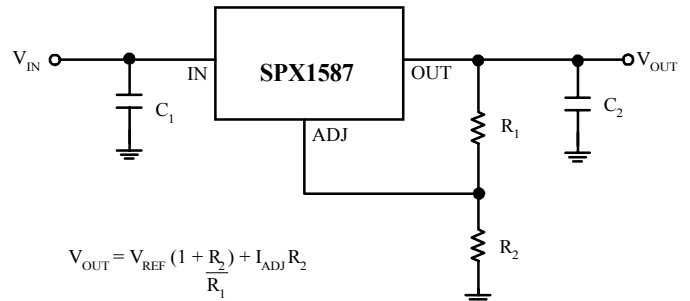

Fig. 5 Typical Adjustable Regulator

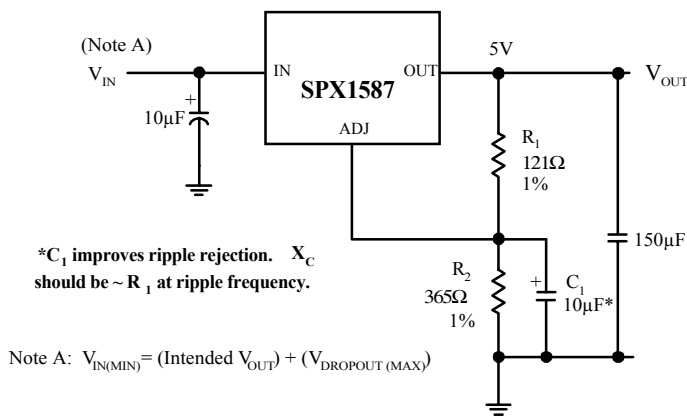

Fig. 6 Improving Ripple Rejection

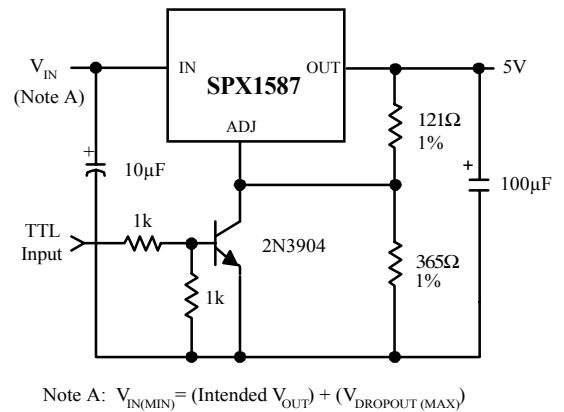
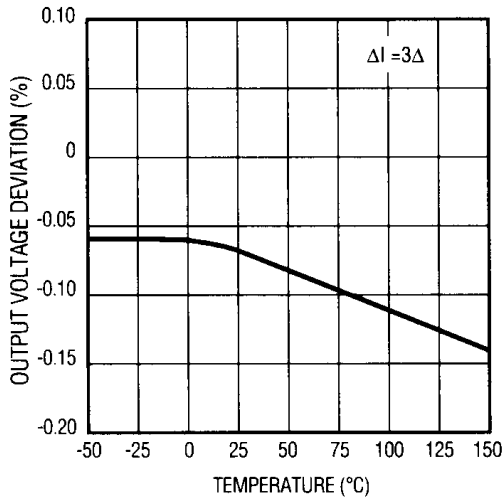

Fig. 7 5V Regulator with Shutdown

TYPICAL CHARACTERISTICS

LOAD REGULATION



SHORT CIRCUIT CURRENT

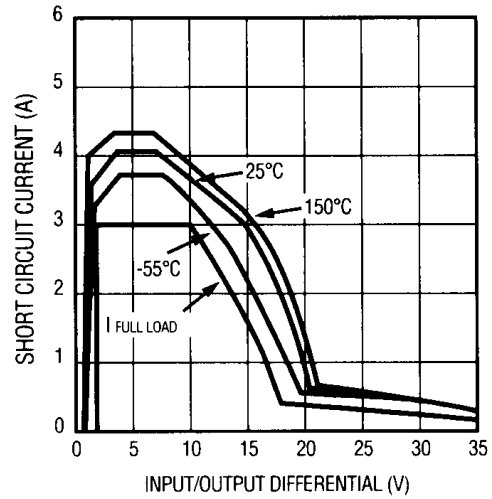

ADJUSTMENT PIN CURRENT

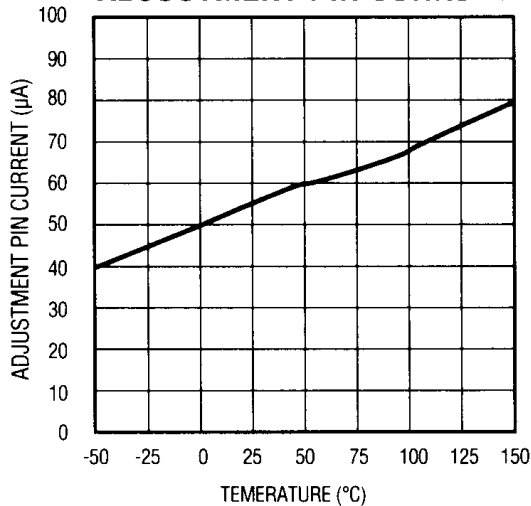

DROPOUT VOLTAGE

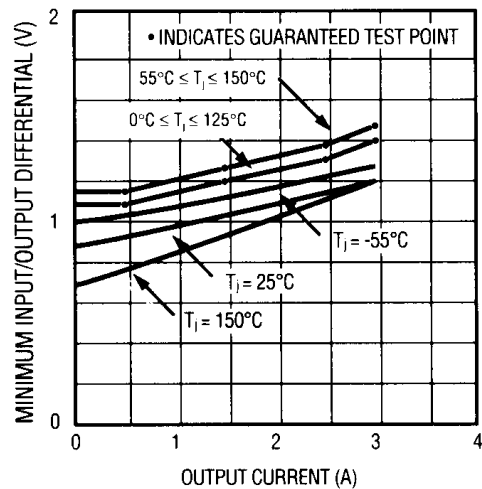

TEMPERATURE STABILITY

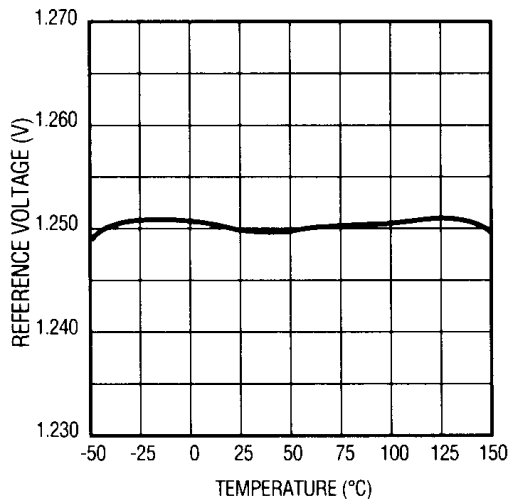

MINIMUM OPERATING CURRENT

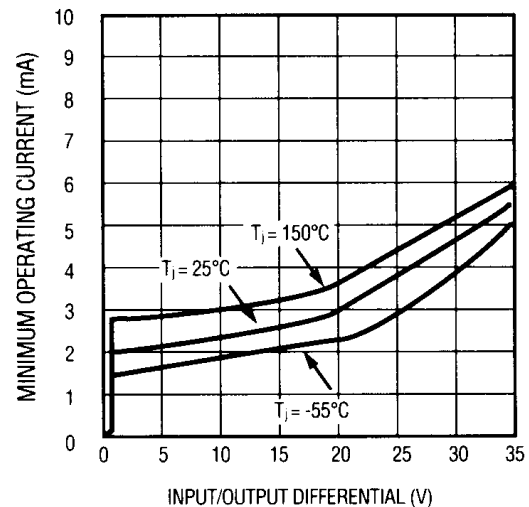

ORDERING INFORMATION

Ordering No.	Precision	Output Voltage	Packages
SPX1587T	2%	Adj	3 Lead TO-263
SPX1587T-1.5	2%	1.5V	3 Lead TO-263
SPX1587T-2.5	2%	2.5V	3 Lead TO-263
SPX1587T-3.3	2%	3.3V	3 Lead TO-263
SPX1587T-5.0	2%	5.0V	3 Lead TO-263
SPX1587AT	1%	Adj	3 Lead TO-263
SPX1587AT-1.5	1%	1.5V	3 Lead TO-263
SPX1587AT-2.5	1%	2.5V	3 Lead TO-263
SPX1587AT-3.3	1%	3.3V	3 Lead TO-263
SPX1587AT-5.0	1%	5.0V	3 Lead TO-263
SPX1587U	2%	Adj	3 Lead TO-220
SPX1587U-1.5	2%	1.5V	3 Lead TO-220
SPX1587U-2.5	2%	2.5V	3 Lead TO-220
SPX1587U-3.3	2%	3.3V	3 Lead TO-220
SPX1587U-5.0	2%	5.0V	3 Lead TO-220
SPX1587AU	1%	Adj	3 Lead TO-220
SPX1587AU-1.5	1%	1.5V	3 Lead TO-220
SPX1587AU-2.5	1%	2.5V	3 Lead TO-220
SPX1587AU-3.3	1%	3.3V	3 Lead TO-220
SPX1587AU-5.0	1%	5.0V	3 Lead TO-220
SPX1587R	2%	Adj	3 Lead TO-252
SPX1587R-1.5	2%	1.5V	3 Lead TO-252
SPX1587R-2.5	2%	2.5V	3 Lead TO-252
SPX1587R-3.3	2%	3.3V	3 Lead TO-252
SPX1587R-5.0	2%	5.0V	3 Lead TO-252
SPX1587AR	1%	Adj	3 Lead TO-252
SPX1587AR-1.5	1%	1.5V	3 Lead TO-252
SPX1587AR-2.5	1%	2.5V	3 Lead TO-252
SPX1587AR-3.3	1%	3.3V	3 Lead TO-252
SPX1587AR-5.0	1%	5.0V	3 Lead TO-252



SIGNAL PROCESSING EXCELLENCE

Sipex Corporation

Headquarters and Main Offices:

22 Linnell Circle
 Billerica, MA 01821
 TEL: (978) 667-8700
 FAX: (978) 670-9001
 e-mail: sales@sipex.com

233 South Hillview Drive
 Milpitas, CA 95035
 TEL: (408) 935-7600
 FAX: (408) 934-7500

Sipex Corporation reserves the right to make changes to any products described herein. Sipex does not assume any liability arising out of the application or use of any product or circuit described hereing; neither does it convey any license under its patent rights nor the rights of others.