



Precision Micropower 1.24V Shunt Voltage Reference

FEATURES

- Low temperature coefficient 50 ppm/°C
- Operating current range 100µA to 15 mA
- Low power, 250 mW @ $I_{IN} = 100$ mA
- Two terminal "Zener" operation
- Small package: SOT - 23, TO-92, and SO-8
- Fixed reverse breakdown voltage 2.5 Volt
- No output capacitance required
- Output voltage tolerance $\pm 0.5\%$

APPLICATIONS

- Constant Current Source
- Digital Voltmeter
- Power Supply Monitor
- Precision Regulators
- Battery-Powered Equipment
- Instrumentation
- Automotive Electronics
- Data Acquisition Systems
- Energy Management

PRODUCT DESCRIPTION

The SPX4041 is a two-terminal, temperature compensated, band-gap voltage reference, which provides a fixed 1.24V output for input currents between 500 µA to 5mA. The bandgap voltage (1.24V) is independently laser trimmed from the output voltage to achieve a very low tempco, then the output voltage is laser trimmed to 1.24 volts. This trimming technique and the low tempco (A grade 50 ppm/ °C) thin film resistor process gives a very stable device over the full temperature range. The SPX4041 is available in the sub-miniature (3mm × 1.3mm) SOT-23, SO-8 surface mount package, or TO-92 package. The operating temperature is -40°C to 85°C.

The SPX4041 advanced design eliminates the need for an external stabilized capacitor while insuring stability with any capacitive load, making them easy to use.

PIN CONNECTIONS

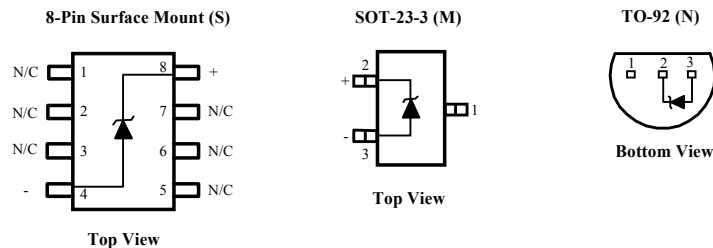

ABSOLUTE MAXIMUM RATINGS

Reverse Current 20mA
 Forward Current 10mA
 Storage Temperature -65°C to +150°C
 Lead Temperature (Soldering) 300°C

Power Dissipation at 25°C
 M Package 300mW
 N Package 550mW
 S Package 525mW
 Temperature Range -40°C ≤ T_A ≤ +85°C

ELECTRICAL CHARACTERISTICS

Electrical Characteristics at I_{IN} = 1000μA, and T_A = +25°C unless otherwise noted. . **Boldface limits apply over temperature.**

Parameters	Conditions	SPX4041A2			SPX4041B2			Units
		Min	Typ	Max	Min	Typ	Max	
Reverse Breakdown Voltage	I _R =500 μA		1.24			1.24		V
Reverse Breakdown Tolerance	I _R =500 μA			±25 ±49			±25 ±49	mV mV
Output Impedance			0.60	2		0.60	2	Ω
Noise Voltage	0.1kHz ≤ f ≤ 10Hz		15			15		μV p-p
Tempco	Note 1			50			100	ppm/°C
Turn-on Setting	0.1% of V _{OUT}		30			30		μSec
Operating Current Range	Note 2	0.5		5 15	0.5		5 15	mA
Temp. Range		-40		85	-40		85	°C
Parameters	Conditions	SPX4041A3			SPX4041B3			Units
Reverse Breakdown Voltage	I _R =500 μA		1.24			1.24		V
Reverse Breakdown Tolerance	I _R =500 μA			±50 ±74			±50 ±74	mV mV
Output Impedance			0.60	2		0.60	2	Ω
Noise Voltage	0.1kHz ≤ f ≤ 10Hz		15			15		μV p-p
Tempco	Note 1			50			100	ppm/°C
Turn-on Setting	0.1% of V _{OUT}		30			30		μSec
Operating Current Range	Note 2	0.1		5 15	0.1		5 15	mA
Temp. Range		-40		85	-40		85	°C

- Note:
- 1) Three-point measurement guarantees the error band over the specified temperature range.
 - 2) Optimum performance is obtained at currents below 1000 μA .
 - 3) Limits are 100% production tested at 25°C. Limits over temperature are guaranteed through correlation using statistical quality control.

SPX4041 Applications Hints

This device is designed for stable operation and has no need of an external capacitor between pin 4 and 8. The reference remains stable if a bypass capacitor is used.

SOT-23

The SPX4041 in the SOT-23 package has a parasitic Schottky diode between pin 3 and pin 1. Pin 1 of SOT-23 must float or be connected to pin 3.

Conventional Shunt Regulator

In a conventional shunt regulator application (see Figure 1), an external series resistor (R_S) is connected between the supply voltage and the SPX4041. R_S determines the current that flows through the load (I_L) and the reference (I_Q). Since load current and supply voltage may vary, R_S should be small enough to supply at least the minimum acceptable I_Q to the reference even when the supply voltage is at its minimum and the load current is at its maximum value. When the supply voltage is at its maximum and I_L is at its minimum, R_S should be large enough so that the current flowing through the SPX4041-x.x is less than 15mA

R_S is determined by the supply voltage (V_S), the load and operating current (I_L and I_Q), reference's reverse breakdown voltage (V_R).

$$R_S = (V_S - V_R)/(I_L + I_Q)$$

Figure 1. SPX4041 Fixed Shunt Regulator Application

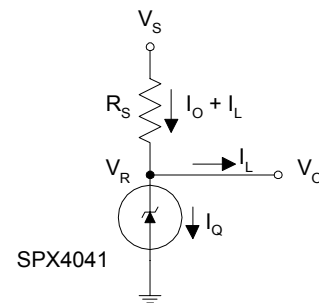

DRAWING PACKAGE
8-PIN SOIC (S)

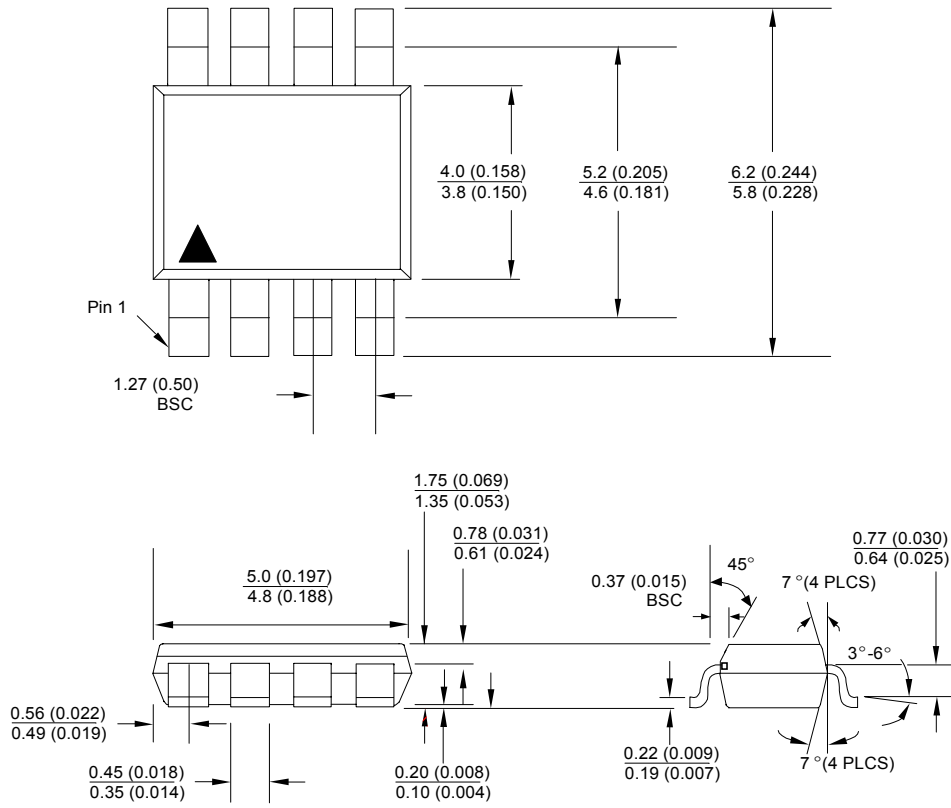

DRAWING PACKAGE
SOT-23-3L (M)

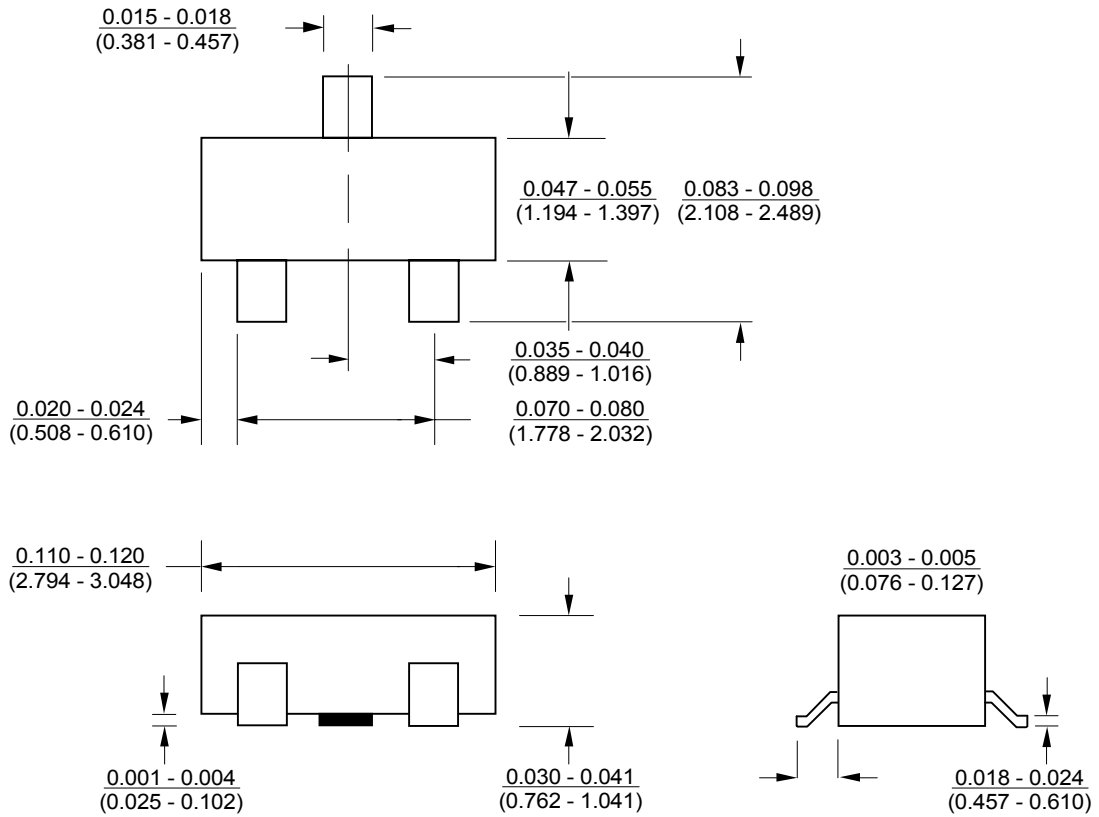

DRAWING PACKAGE
TO-92 (N)

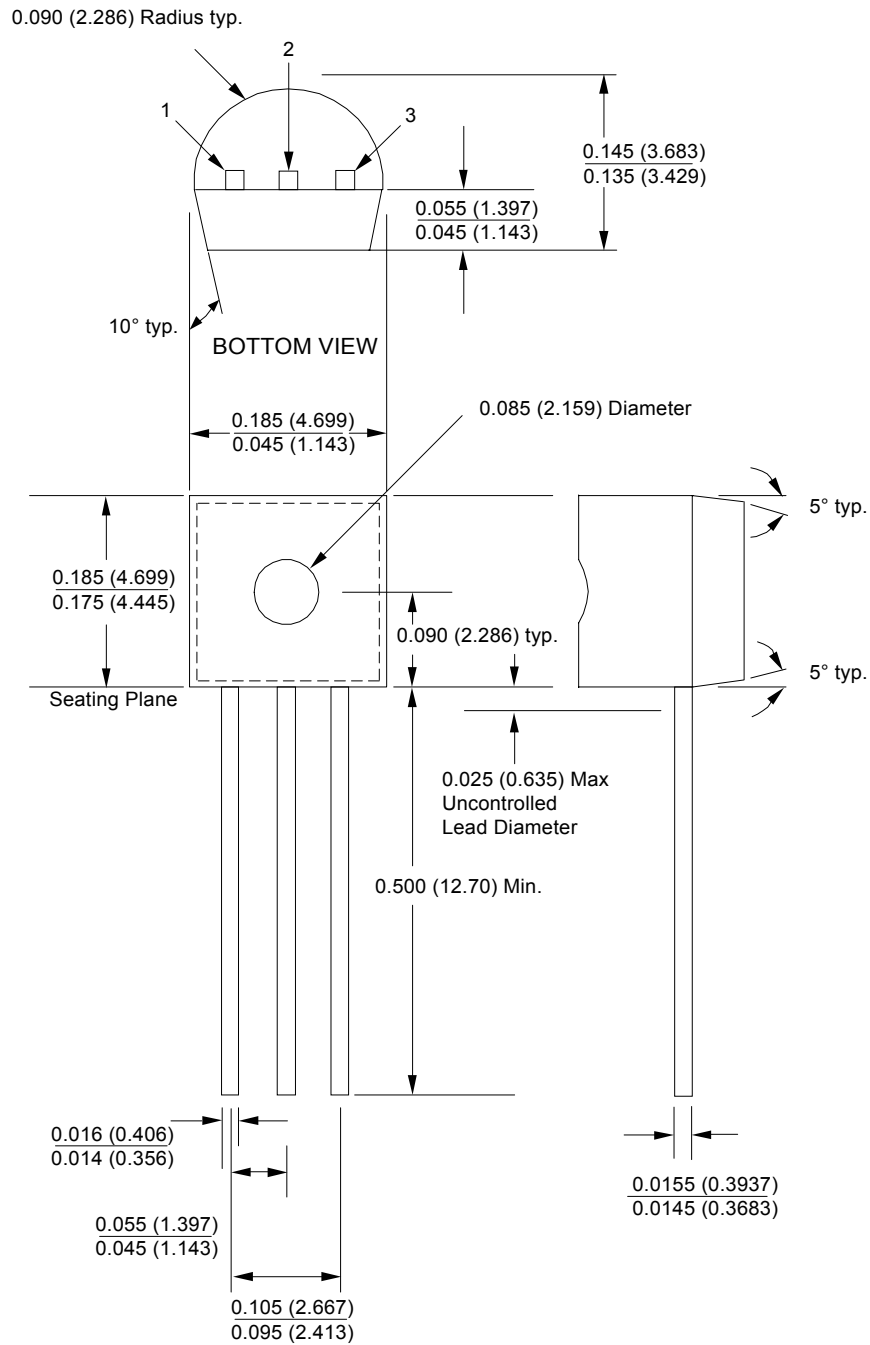

ORDERING INFORMATION

Ordering No.	Temp Coef.	Output Accuracy	Packages
SPX4041AN-2	100ppm	1%	3 Lead TO-92
SPX4041AN-3	100ppm	2%	3 Lead TO-92
SPX4041BN-2	150ppm	1%	3 Lead TO-92
SPX4041BN-3	150ppm	2%	3 Lead TO-92
SPX4041AM-2	100ppm	1%	3 Lead SOT-23
SPX4041AM-3	100ppm	2%	3 Lead SOT-23
SPX4041BM-2	150ppm	1%	3 Lead SOT-23
SPX4041BM-3	150ppm	2%	3 Lead SOT-23
SPX4041AS-2	100ppm	1%	8 Lead SOIC
SPX4041AS-3	100ppm	2%	8 Lead SOIC
SPX4041BS-2	150ppm	1%	8 Lead SOIC
SPX4041BS-3	150ppm	2%	8 Lead SOIC



SIGNAL PROCESSING EXCELLENCE

Sipex Corporation

Headquarters and Main Offices:
22 Linnell Circle
Billerica, MA 01821
TEL: (978) 667-8700
FAX: (978) 670-9001
e-mail: sales@sipex.com

233 South Hillview Drive
Milpitas, CA 95035
TEL: (408) 935-7600
FAX: (408) 934-7500

Sipex Corporation reserves the right to make changes to any products described herein. Sipex does not assume any liability arising out of the application or use of any product or circuit described hereing; neither does it convey any license under its patent rights nor the rights of others.