

**Mechanical Date**

- Case:TO-220
- Case Material: Molded Plastic, UL Flammability Classification Rating 94V-0
- Terminals: Matte Tin Finish annealed over copper Lead frame. Solderable per MIL-STD-202
- Weight: 1.948 grams (approximate)

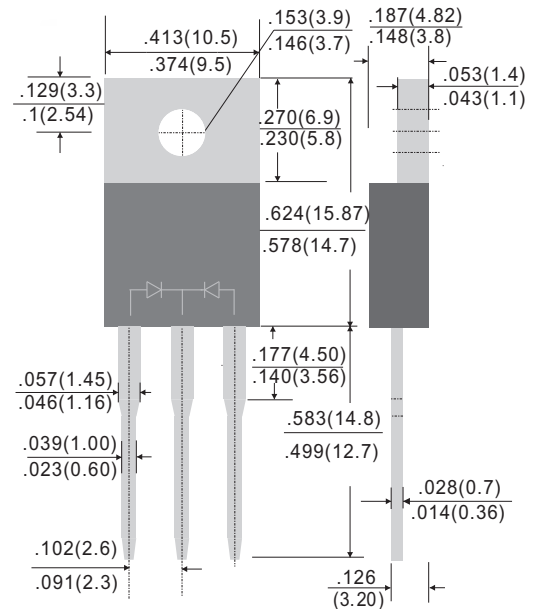

**TO-220**



Dimensions in inches and (millimeters)

**Features**

- Guard Ring for over voltage Protection
- High forward surge capability
- High frequency operation
- Component in accordance to RoHS 2002/95/EC
- **Pb-Free package is available**  
RoHS product for packing code suffix "G"  
Halogen free product for packing code suffix "H"

MAXIMUM RATINGS (TA=25°C unless otherwise noted)							
PARAMETER	SYMBOL	SR2040C	SR2060C	SR20100C	SR20150C	SR20200C	UNIT
Maximum repetitive peak reverse voltage	$V_{RRM}$	40	60	100	150	200	V
Maximum RMS voltage	$V_{RMS}$	28	42	70	105	140	V
Maximum DC blocking voltage	$V_{DC}$	40	60	100	150	200	V
Maximum average forward rectified current (Total) (Per Leg)	$I_F$	20 10					A
Peak forward surge current, 8.3ms single half sine-wave superimposed on rated load	$I_{FSM}$	150.0					A
Maximum Instantaneous Forward Voltage IF=10A @ 25°C	$V_F$	0.55	0.75	0.85	0.92		V
Maximum DC Reverse Current @ Tc=25°C at Rated DC Blocking Voltage @ Tc=100°C	$I_R$	0.5 20		0.2 5			mA
Typical Junction Capacitance(NOTE1)	$C_j$	600	400		300		pF
Typical Thermal Resistance	$R_{\theta JC}$	3					°C/W
Operating Temperature Range	$T_J$	-55 to +125			-55 to +150		°C
Storage Temperature Range	$T_{STG}$	-55 to +150					°C

NOTES:1.Measured at 1.0MHZ and applied reverse voltage of 4.0V DC

FIG. 1-TYPICAL FORWARD CURRENT DERATING CURVE

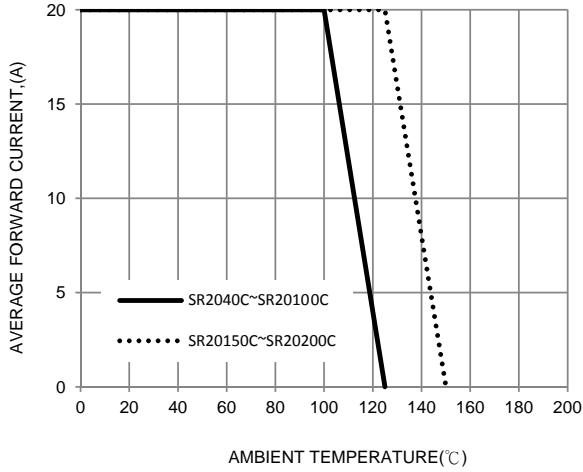

FIG. 2-TYPICAL FORWARD CHARACTERISTICS

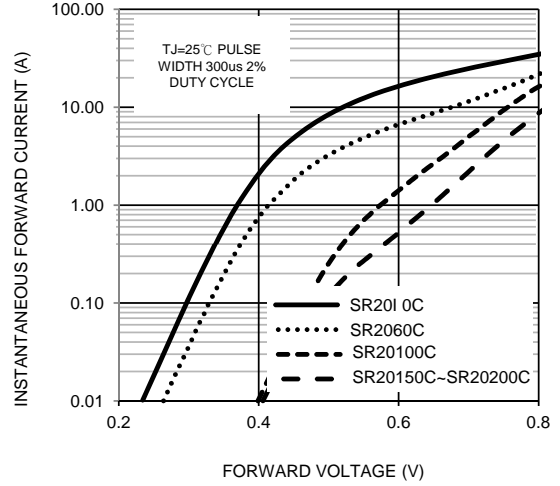

FIG. 3-MAXIMUM NON-REPETITIVE FORWARD SURGE CURRENT

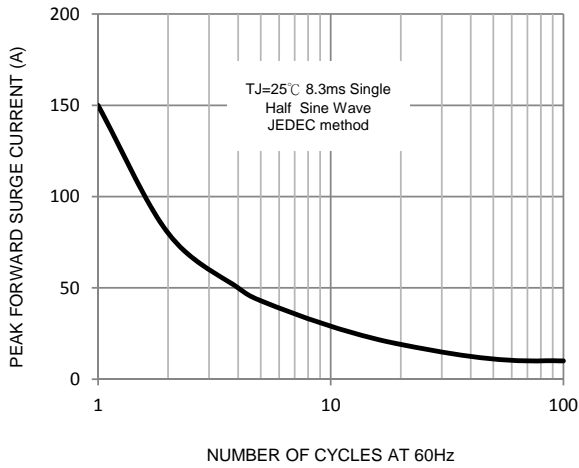

FIG. 4-TYPICAL REVERSE CHARACTERISTICS

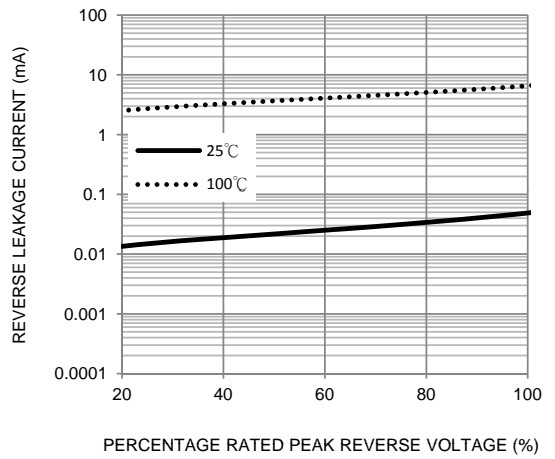

FIG. 5-TYPICAL JUNCTION CAPACITANCE

