

SR502 THRU SR510

SCHOTTKY BARRIER RECTIFIERS

Reverse Voltage – 20 to 100 V

Forward Current – 5 A

Features

- Plastic package has Underwriters Laboratory Flammability Classification 94V-0
- Metal silicon junction, majority carrier conduction
- Low power loss, high efficiency
- High current capability, low forward voltage drop
- For use in low voltage, high frequency inverters, free wheeling, and polarity protection applications

Mechanical Data

- Case: JEDEC DO-201AD molded plastic body
- Terminals: Plated axial leads, solderable per MIL-STD-750, method 2026
- Polarity: color band denotes cathode end

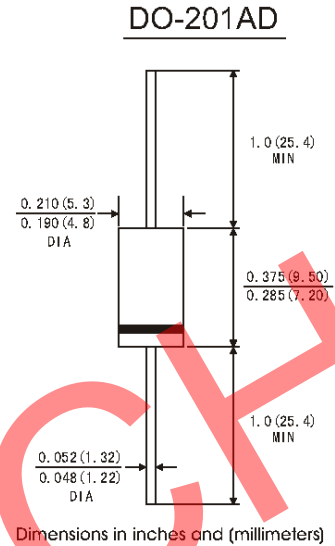

Maximum Ratings and Electrical Characteristics

Ratings at 25 °C ambient temperature unless otherwise specified. Single phase, half wave, resistive or inductive load. For capacitive load, derate by 20%.

Parameter	Symbols	SR502	SR503	SR504	SR505	SR506	SR508	SR510	Units
Maximum Repetitive Peak Reverse Voltage	V_{RRM}	20	30	40	50	60	80	100	V
Maximum RMS Voltage	V_{RMS}	14	21	28	35	42	57	71	V
Maximum DC Blocking Voltage	V_{DC}	20	30	40	50	60	80	100	V
Maximum Average Forward Rectified Current 0.375"(9.5mm) Lead Length	$I_{F(AV)}$	5							A
Peak Forward Surge Current, 8.3 ms Single Half Sine Wave Superimposed on Rated Load (JEDEC method at Rated T_L)	I_{FSM}	150							A
Maximum Forward Voltage at 5 A ¹⁾	V_F	0.55		0.7		0.85		V	
Maximum DC Reverse Current at $T_a = 25\text{ }^\circ\text{C}$ Rated DC Blocking Voltage $T_a = 100\text{ }^\circ\text{C}$	I_R	0.5							mA
Typical Junction Capacitance ³⁾	C_J	500		400				pF	
Typical Thermal Resistance ²⁾	$R_{\theta JA}$ $R_{\theta JL}$	25 8							$^\circ\text{C/W}$
Operating Junction Temperature Range	T_J	- 65 to + 125			- 65 to + 150			$^\circ\text{C}$	
Storage Temperature Range	T_{Stg}	- 65 to + 150							$^\circ\text{C}$

¹⁾ Pulse test: 300 μs pulse width, 1% duty cycle

²⁾ Thermal resistance from junction to lead vertical P.C.B. mounted, 0.375"(9.5mm) lead length

³⁾ Measured at 1 MHz and applied reverse voltage of 4 V

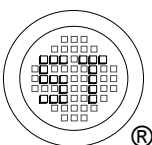

SEMTECH ELECTRONICS LTD.
Subsidiary of Sino-Tech International (BVI) Limited



Dated : 02/09/2008 J

SR502 THRU SR510

FIG.1-FORWARD CURRENT DERATING CURVE

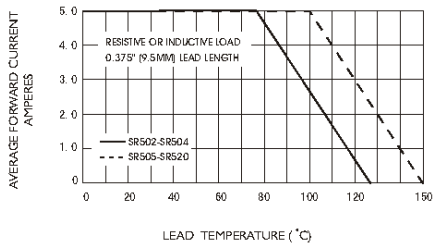

FIG.2-MAXIMUM NON-REPETITIVE PEAK FORWARD SURGE CURRENT

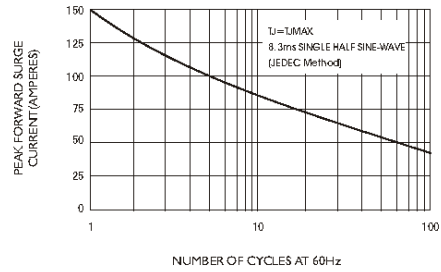

FIG.3-TYPICAL INSTANTANEOUS FORWARD CHARACTERISTICS

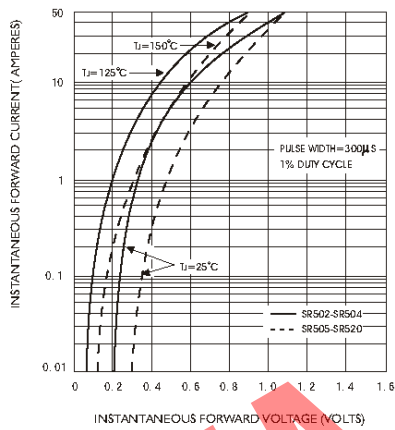

FIG.4-TYPICAL REVERSE CHARACTERISTICS

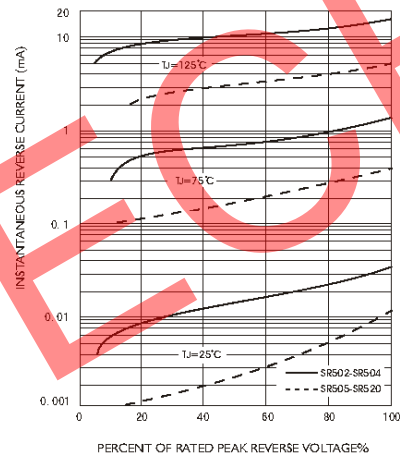

FIG.5-TYPICAL JUNCTION CAPACITANCE

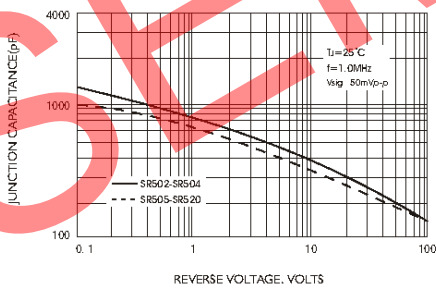
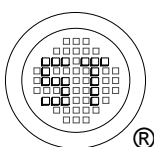
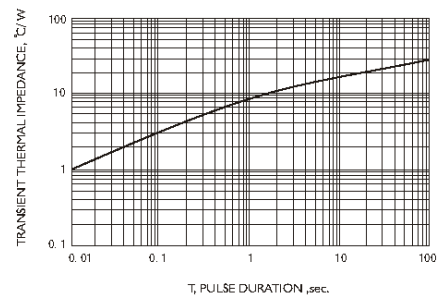

FIG.6-TYPICAL TRANSIENT THERMAL IMPEDANCE



SEMTECH ELECTRONICS LTD.
Subsidiary of Sino-Tech International (BVI) Limited

