

SR802 - SR806

SCHOTTKY BARRIER RECTIFIER DIODES

PRV : 20 - 60 Volts
I_o : 8.0 Amperes

FEATURES :

- * High current capability
- * High surge current capability
- * High reliability
- * Low forward voltage drop
- * **Pb / RoHS Free**

MECHANICAL DATA :

- * Case : DO-201AD Molded plastic
- * Epoxy : UL94V-O rate flame retardant
- * Lead : Axial lead solderable per MIL-STD-202, Method 208 guaranteed
- * Polarity : Color band denotes cathode end
- * Mounting position : Any
- * Weight : 1.1 grams

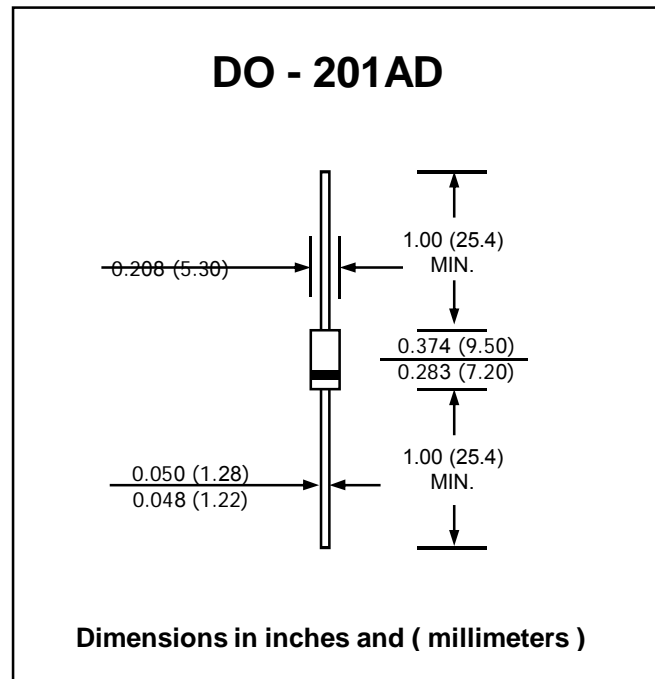

MAXIMUM RATINGS AND ELECTRICAL CHARACTERISTICS

Rating at 25 °C ambient temperature unless otherwise specified. Single phase, half wave, 60 Hz, resistive or inductive load.
For capacitive load, derate current by 20%.

RATING	SYMBOL	SR802	SR803	SR804	SR805	SR806	UNIT
Maximum Recurrent Peak Reverse Voltage	V _{RRM}	20	30	40	50	60	V
Maximum RMS Voltage	V _{RMS}	14	21	28	35	42	V
Maximum DC Blocking Voltage	V _{DC}	20	30	40	50	60	V
Maximum Average Forward Current ,See Fig.1	I _{F(AV)}	8.0					A
Maximum Peak Forward Surge Current, 8.3ms single half sine wave superimposed on rated load (JEDEC Method)	I _{FSM}	175					A
Maximum Forward Voltage at I _F = 8 A	V _F	0.55		0.70		V	
Maximum Reverse Current at Ta = 25 °C	I _R	0.5					mA
Rated DC Blocking Voltage Ta = 100 °C	I _{R(H)}	50					mA
Typical Thermal Resistance (Note 1)	R _{θJA}	40					°C/W
Typical Junction Capacitance (Note 2)	C _J	500			270		pF
Operating Junction Temperature Range	T _J	- 65 to + 125			- 65 to + 150		°C
Storage Temperature Range	T _{STG}	- 65 to + 150					°C

Notes :

- (1) Mount on Cu-Pad Size 16mm x 16mm on P.C.B.
- (2) Measured at 1 MHz and Applied Reverse Voltage of 4.0V D.C.

RATING AND CHARACTERISTIC CURVES (SR802 - SR806)

FIG.1 - FORWARD CURRENT DERATING CURVE

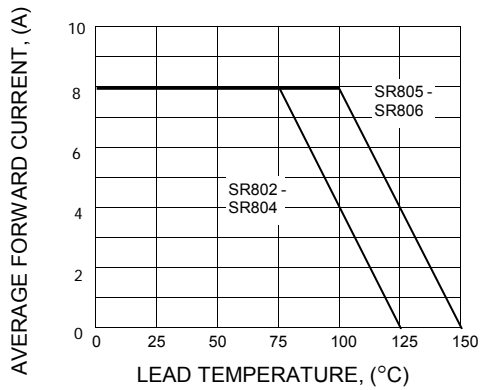

FIG.2 - MAXIMUM NON-REPETITIVE PEAK FORWARD SURGE CURRENT

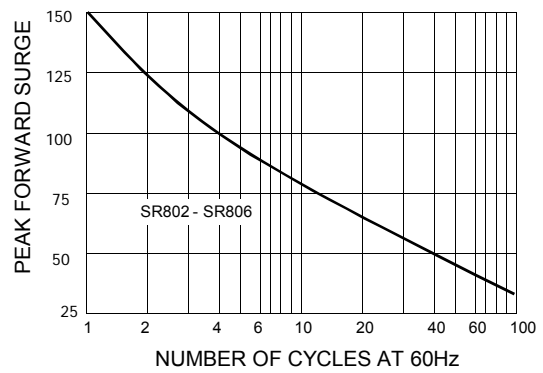

FIG.3 - TYPICAL FORWARD CHARACTERISTICS

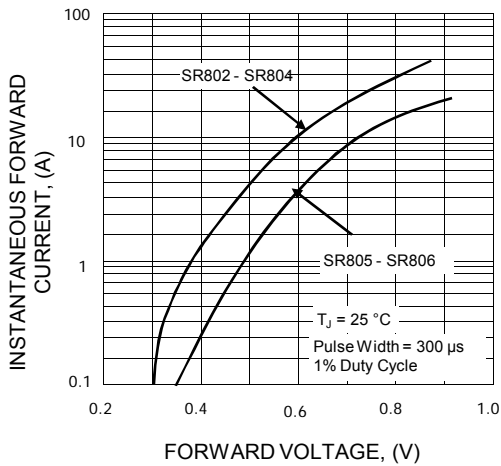

FIG.4 - TYPICAL REVERSE CHARACTERISTICS

