

NON-ISOLATED DC/DC CONVERTERS

3.3 V Input 5 V/4 A Output

bel
POWER PRODUCTS

SRDB-04C500

RoHS Compliant

- Non-Isolated
- High Efficiency
- Fixed Frequency (530 kHz)
- Low Profile Package (8.5 mm)
- Remote Sense
- Allows Burst Mode Operation at Low Load Currents



www.DataSheet4U.com

Description

The SRDB-04C500 is part of the low cost non-isolated dc/dc series. The module uses a DIP package for ease of layout and space savings, with a low profile of 8.5mm. The output is closely regulated and the efficiency is typically 92% at full load. The unit is designed to be highly efficient and cost-effective. Features include remote sense, output voltage adjustment and burst mode at light load.

Part Selection

Output Voltage	Input Voltage	Max. Output Current	Max. Output Power	Typical Efficiency	Model Number
5 V	3.3 V	4 A	20 W	92%	SRDB-04C500

Note: Add "R" suffix at the end of the model number to indicate "Reel Packaging", and "G" for "Tray Packaging".

Absolute Maximum Ratings

Parameter	Min	Typ	Max	Notes
Input Voltage (continuous)	2.8 V	-	4 V	
Ambient Temperature	0 °C	-	70 °C	
Storage Temperature	-40 °C	-	125 °C	

Input Specifications

Parameter	Min	Typ	Max	Notes
Input Voltage	3 V	-	3.6 V	
Input Current (full load)	-	-	8.5 A	
Input Reflected Ripple Current (pk-pk)	-	120 mA	200 mA	Tested with simulated source impedance of 500 nH, 5 Hz to 20 MHz; 270 uF/16 V capacitors with ESR=0.018 ohm max. at 100KHz
Input Reflected Ripple Current (rms)	-	25 mA	50 mA	
I ² t Inrush Current Transient	-	0.02 A ² s	0.05 A ² s	
Turn-on Voltage Threshold	-	2.8 V	2.9 V	

Note: All specifications are typical at 25 °C unless otherwise stated.

NON-ISOLATED DC/DC CONVERTERS

3.3 V Input 5 V/4 A Output



Output Specifications

Parameter	Min	Typ	Max	Notes		
Output Voltage Set Point	4.85 V	5.0 V	5.15 V	Vin=3.3 V, full load		
Line Regulation	-	20 mV	40 mV			
Load Regulation	-	30 mV	60 mV			
Regulation Over Temperature (0 °C to 70 °C)	-	20 mV	30 mV			
Ripple and Noise (rms) ¹	-	15 mV	25 mV			
Ripple and Noise (pk-pk) ¹	-	100 mV	-	Burst Mode; Io=0 A		
	-	70 mV	100 mV	Fixed frequency; Io=4 A		
Output Current	0 A	-	4 A			
Rise Time	-	30 mS	50 mS			
Overshoot at Turn on	-	0%	5%			
Output Capacitance	0 uF		2000 uF			
Transient Response						
50% ~ 100% Max Load	Overshoot	Vo=5 V	-	100 mV	Tested at di/dt=0.5 A/us, Vin=3.3 Vdc, without external load capacitance	
	Settling Time		-	60 uS		120 uS
100% ~ 50% Max Load	Overshoot		-	100 mV		150 mV
	Settling Time		-	60 uS		120 uS

Notes: All specifications are typical at nominal input, full load at 25 °C unless otherwise stated.

1. Test condition of the output ripple and noise: 0-20 MHz BW; recommend a 220 uF capacitor at output if the module operates at burst mode (light load).

General Specifications

Parameter	Min	Typ	Max	Notes
Efficiency	88%	92%	-	Vin=3.3 V, full load
Switching Frequency	460 kHz	530 kHz	630 kHz	
Output Voltage Trim Range	90% Vo	-	110% Vo	Typical at nominal input, full load at 25 °C unless otherwise stated.
Remote Sense Compensation	-	-	10%	
MTBF	7,600,000 hours			Calculated Per Bell Core SR-332 (Vin=3.3 V; Vo=5 V; Io = 3.2 A; Ta = 25 °C)
Dimensions	Inches millimeters 1.22 x 0.827 x 0.345 30.99 x 21.0 x 8.76			
Weight	-	11 g	-	

Note: All specifications are typical at 25 °C unless otherwise stated.

NON-ISOLATED DC/DC CONVERTERS

3.3 V Input 5 V/4 A Output



Output Trim Equations

Equations for calculating the trim resistor (in kΩ) given the desired adjusted voltage (V_{adj}) and the nominal output voltage of the converter (V_{nom}) are shown below. The Trim Down resistor should be connected between the Trim pin and V_{out} . The Trim Up resistor should be connected between the Trim pin and Ground. Only one of the resistors should be used for any given application.

www.DataSheet4U.com

$$R_{trim-down} = \frac{12.109}{V_{nom} - V_{adj}} - 8.79$$

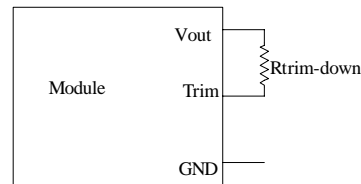

$$R_{trim-up} = \frac{3.82}{V_{adj} - V_{nom}} - 5.62$$

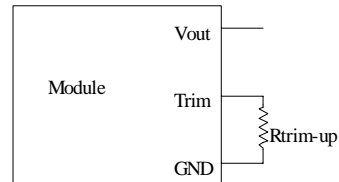

Note: For Trim Up, the output voltage $V_{nom} = 5.025$ V

Efficiency Data

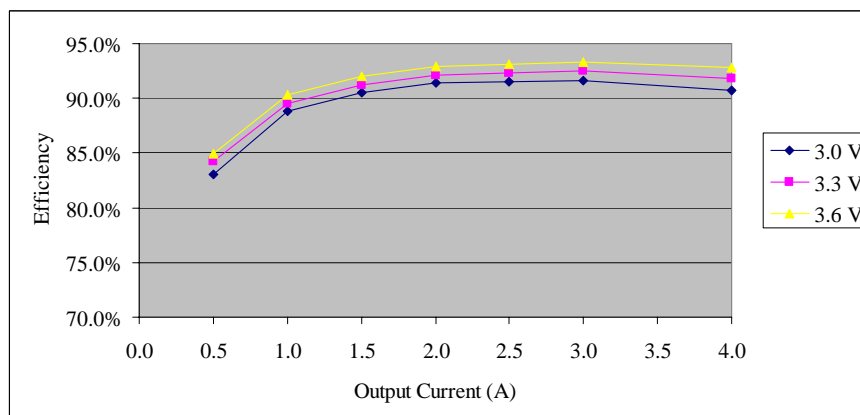

Vo=5 V

NON-ISOLATED DC/DC CONVERTERS

3.3 V Input 5 V/4 A Output



Thermal Derating Curve

www.DataSheet4U.com

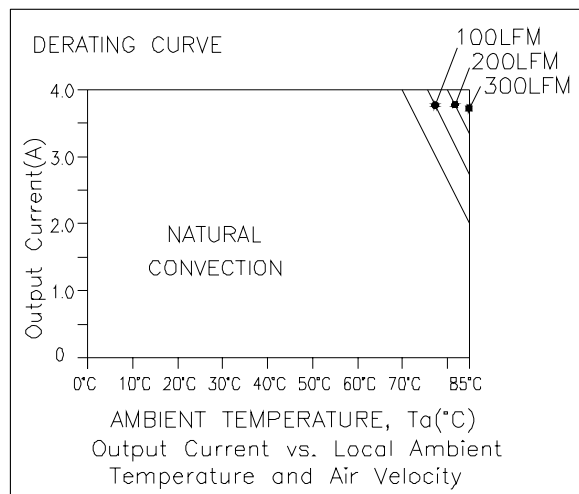

SRDB-04C500

NON-ISOLATED DC/DC CONVERTERS

3.3 V Input 5 V/4 A Output

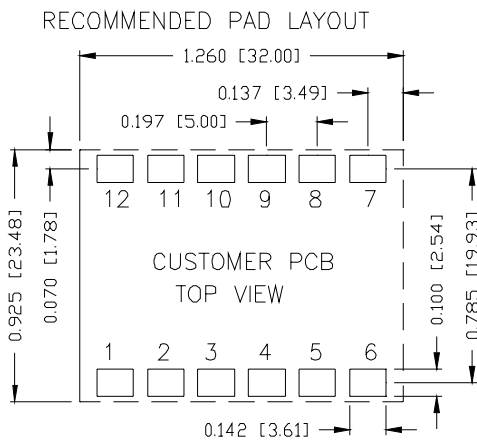
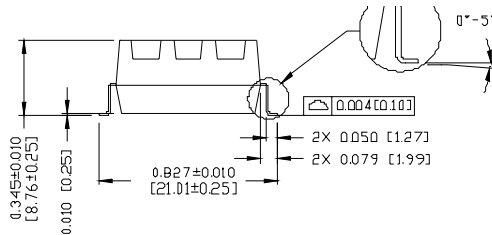
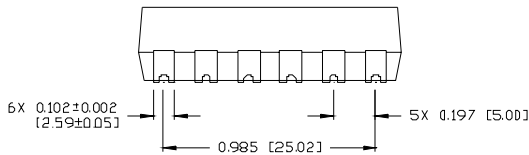
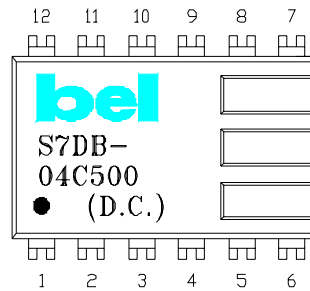
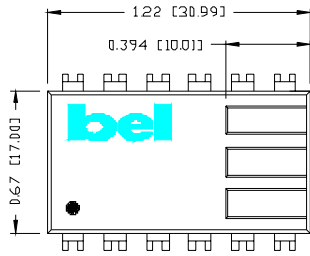

DON'T PLACE OTHER COMPONENTS IN THIS DASHED AREA

Pin Connections

Pin	Function
1	Trim
2	N/A
3	Remote Sense(+)
4	Vo
5	Vo
6	Vo
7	Ground
8	Ground
9	Ground
10	Vin
11	Vin
12	Vin

RoHS Compliance

Complies with the European Directive 2002/95/EC, calling for the elimination of lead and other hazardous substances from electronic products. These parts are not however compatible with the higher temperatures associated with lead free solder processes and must be soldered using a reflow profile with a peak temperature of no more than 240 °C.



©2005 Bel Fuse Inc. Specifications subject to change without notice. 091905

CORPORATE

Bel Fuse Inc.
206 Van Vorst Street
Jersey City, NJ 07302
Tel 201-432-0463
Fax 201-432-9542
www.belfuse.com

FAR EAST

Bel Fuse Ltd.
8F/ 8 Luk Hop Street
San Po Kong
Kowloon, Hong Kong
Tel 852-2328-5515
Fax 852-2352-3706
www.belfuse.com

EUROPE

Bel Fuse Europe Ltd.
Preston Technology Management Centre
Marsh Lane, Suite G7, Preston
Lancashire, PR1 8UD, U.K.
Tel 44-1772-556601
Fax 44-1772-888366
www.belfuse.com