

LLC Resonance Power Transformers

Pin terminal type

SRX/SRV series

SRX43EM (Through hole)
SRX25EM (Through hole)
SRX30ER-I (Through hole)
SRX30ER-II (Through hole)
SRX35ER (Through hole)
SRX48EM (Through hole)
SRX40ER (Through hole)
SRV3914EE (Through hole)
SRV4214EE (Through hole)
SRV4215ES (Through hole)
SRV4715ER (Through hole)

An attention matter on use

Please read this specifications before using this product by all means.

An attention matter on security

I undertake use with this product, and it is paid attention enough, and please design an attention matter safely.

Attention on a design

- When you designs a base of an electric circuit.
Please use size of the hole or pad which we recommend.
- Magnetic flux to leak out occurs. Please confirm it about influence of magnetic flux beforehand.
There is fear to cause false movement of machinery.
- In a design of a base of an electric circuit, Please consider the next contents.
In an applied safe standard.
The trans and distance with other parts
- The product is not quakeproof structure.
Accordingly please do not add vibration and a shock to it.
There is fear to lose a function.

Attention on the handling

- Please do not use it when you let a product drop.
The product produces possibility to lose a function
- Please pay attention to the pin which had it pointed keenly.
There is danger to injure.
- Please avoid the next place. The place that receives a drop of water, trash, the dust, foggy influence. The place where direct rays of the sun hits. There is fear to cause false movement of machinery.
- Please prohibit safekeeping and use at the next place. Environment to be accompanied with gas corrosion, salt, acid, alkali. There is fear to lose a function.
- When you carry the product on a base of an electric circuit.
Please do not use a metal tool. Because impossible power is added to a product.
There is fear to lose a function.

Attention

- I considered the next matter, and we designed a product.
Safe standard and power supply voltage and circuit drive condition, drive frequency and Duty ON-TIME.
By those conditions, we decided structure and the turns number.
Please avoid use in designed condition outside.
There are destruction of a circuit part and fear of ignition.
- This product considered a characteristic of a component and a self temperature rise, and it was made.
We select range of humidity as use temperature already.
Please avoid use by range more than this.
There are the damage and fear of ignition.
- Please avoid use in the environment next.
The environment that trash and the dust stick to a product. There is fear to cause a fire.
- The products listed on this specification sheet are intended for use in general electronic equipment (AV equipment, telecommunications equipment, home appliances, amusement equipment, computer equipment, personal equipment, office equipment, measurement equipment, industrial robots) under a normal operation and use condition.
- The products are not designed or warranted to meet the requirements of the applications listed below, whose performance and/or quality require a more stringent level of safety or reliability, or whose failure, malfunction or trouble could cause serious damage to society, person or property.
- If you intend to use the products in the applications listed below or if you have special requirements exceeding the range or conditions set forth in this catalog, please contact us.

- (1) Aerospace/Aviation equipment
- (2) Transportation equipment (cars, electric trains, ships, etc.)
- (3) Medical equipment
- (4) Power-generation control equipment
- (5) Atomic energy-related equipment
- (6) Seabed equipment applications
- (7) Transportation control equipment

- (8) Public information-processing equipment
- (9) Military equipment
- (10) Electric heating apparatus, burning equipment
- (11) Disaster prevention/crime prevention equipment
- (12) Safety equipment
- (13) Other applications that are not considered general-purpose applications

When designing your equipment even for general-purpose applications, you are kindly requested to take into consideration securing protection circuit/device or providing backup circuits in your equipment.

• All specifications are subject to change without notice.

LLC Resonance Power Transformers

SRX/SRV series

| Contents | Page |
|--|------|
| Development Concept | 4 |
| Overview | 5 |
| Product Lineup | 7 |
| SRX43EM-(Height from the board: 15mm) | 8 |
| SRX25EM (Height from the board: 20mm) | 9 |
| SRX30ER-I , SRX30ER-II (Height from the board: 25mm, 27mm) | 10 |
| SRX35ER (Height from the board: 25mm) | 11 |
| SRX48EM (Height from the board: 25mm) | 12 |
| SRX40ER (Height from the board: 31.5mm) | 13 |
| SRV3914EE (Height from the board: 15mm) | 14 |
| SRV4214EE (Height from the board: 15mm) | 15 |
| SRV4215ES (Height from the board: 16mm) | 16 |
| SRV4715ER (Height from the board: 16mm) | 17 |
| Design Material for LLC Resonance Power Transformers (Reference) | 18 |
| Design Reference for Specification Request Forms | 24 |

• All specifications are subject to change without notice.

LLC Resonance Power Transformers

Pin terminal type

Development Concept of the SRX/SRV Series

Compliant with worldwide safety standards, this is a small and thin transformer with the advantages of effective use of low-loss ferrite material.

■ MATERIAL

Optimized materials and core shapes have been developed. The necessary power can be transmitted with a small number of turns.

While optimizing materials, TDK has further improved its proprietary core shape to develop a new-type core.

The transformer has been downsized considerably, and its temperature increase has also been curbed.

■ MANUFACTURING METHOD

Since the SRX/SRV Series supports automatic winding, the product is of a high quality and can be manufactured stably.

It is designed to support automatic winding, which enables a remarkable reduction in the loss generated to achieve a proficient in manual winding until stable production.

In addition, the characteristic variations of the winding wire and creepage tape have largely been removed, stabilizing the transformer's characteristics.

■ OPTIMIZATION DESIGN

Using design tools developed with TDK's comprehensive know-how, high-precision design has been achieved in a short period of time.

1) For optimization design and high-quality stable production, customers can use a specification request form.

2) TDK recommends design with a standard core gap (AL-value) for optimization and shorter trial and mass production lead time.

Design is simple as each shape retains its GAP, AL-value, and K parameters beforehand.

■ ENVIRONMENT

The SRX/SRV series is RoHS directive-compliant product.

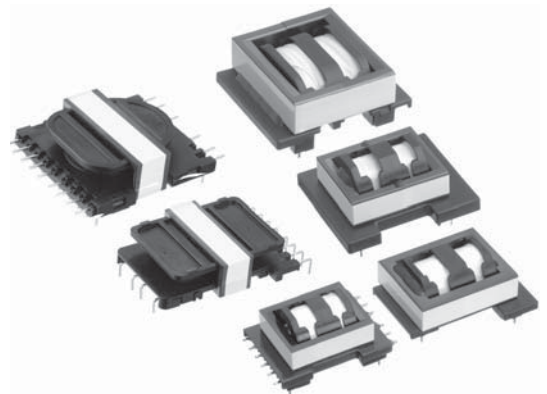

LLC Resonance Power Transformers

Product compatible with RoHS directive
Compatible with lead-free solders

Pin terminal type

Overview of the SRX/SRV Series

TDK now provides characteristically thin resonance LLC resonance power transformers. In order to develop these transformers, TDK made effective use of low loss performance (which is a feature of the PC47 family), optimized the structure of the core and the bobbin, and utilized its proprietary automatic winding industrial method.

FEATURES

- A low height (15 to 31.5mm in height) is achieved.
- Large power is achieved in a small shape.
- The automatic winding industrial method is adopted.
- Product compatible with RoHS directive.

APPLICATION

AV equipment, digital home appliance

PART NUMBER CONSTRUCTION

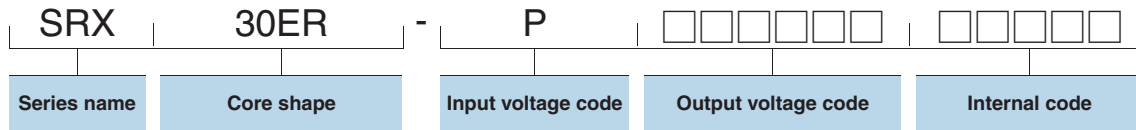

○ RoHS Directive Compliant Product: See the following for more details related to RoHS Directive compliant products. <http://www.tdk.co.jp/rohs/>

• All specifications are subject to change without notice.

Overview of the SRX/SRV Series

ELECTRICAL CHARACTERISTICS

| Type | Mount method | HeightH (mm) | Frequency (kHz)min. | Maximum output power (W)max. | Number of outputs | Depth D (mm) | Width W (mm) | Lead space F (mm) | Number of pins(pieces) | |
|-----------------|--------------|-----------------|------------------------|------------------------------------|----------------------|-----------------|-----------------|-------------------------|------------------------|-------------------|
| | | | | | | | | | Primary side | Secondary side |
| Horizontal type | | | | | | | | | | |
| SRX43EM | Through hole | 15 | 100 | 180 | 2 | 55 | 46 | 37.5 | 5 | 7 |
| SRX25EM | Through hole | 20 | 100 | 100 | 2 | 47.6 | 36.1 | 32 | 5 | 6 |
| SRX30ER-I | Through hole | 27 | 100 | 180 | 2 | 57 | 41.5 | 40 | 6 | 6 |
| SRX30ER-II | Through hole | 25 | 100 | 180 | 3 | 52 | 45.5 | 35 | 8 | 8 |
| SRX35ER | Through hole | 25 | 80 | 250 | 3 | 55 | 53 | 35 | 6 | 9 |
| SRX48EM | Through hole | 25 | 60 | 300 | 3 | 58 | 51 | 35 | 6 | 8 |
| SRX40ER | Through hole | 31.5 | 60 | 300 | 3 | 54 | 43 | 35 | 8 | 8 |
| Vertical type | | | | | | | | | | |
| SRV3914EE | Through hole | 15 | 100 | 160 | 2 | 64 | 43.5 | 64 | 4 | 8 |
| SRV4214EE | Through hole | 15 | 100 | 200 | 2 | 64 | 43.5 | 64 | 4 | 8 |
| SRV4215ES | Through hole | 16 | 100 | 200 | 2 | 64 | 49 | 44 | 6 | 9 |
| SRV4715ER | Through hole | 16 | 100 | 250 | 2 | 64 | 52 | 44 | 6 | 9 |

Horizontal type (general)

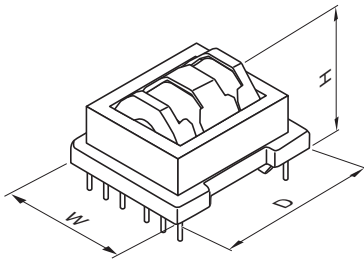

Vertical type (shielded)

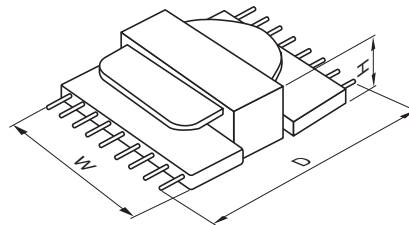

Product Lineup

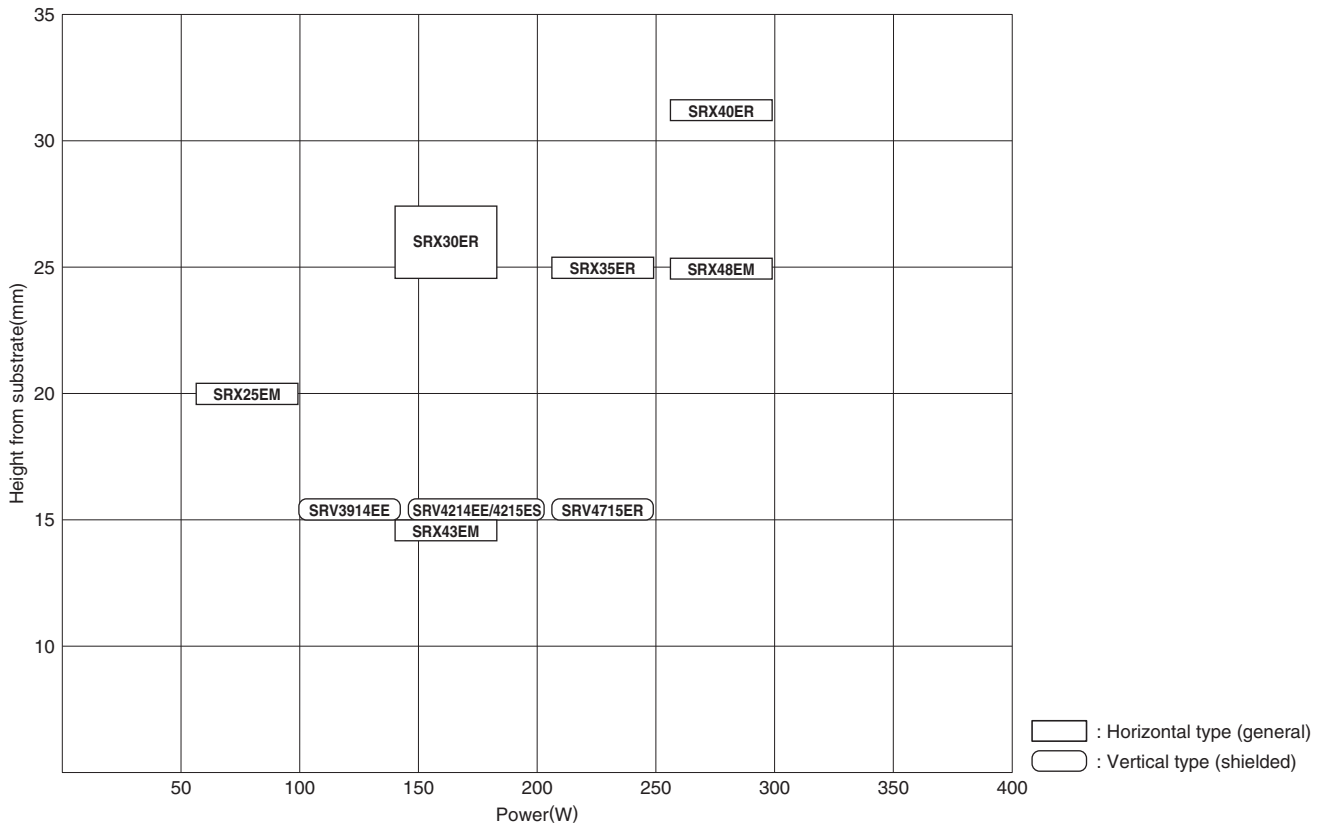

Horizontal type (general)

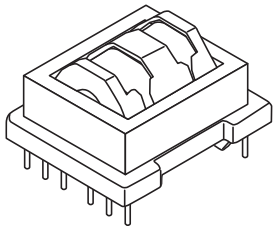

Vertical type (shielded)

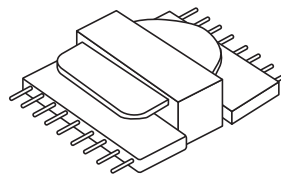

• All specifications are subject to change without notice.

SRX series

SRX43EM Type

SHAPE & DIMENSIONS

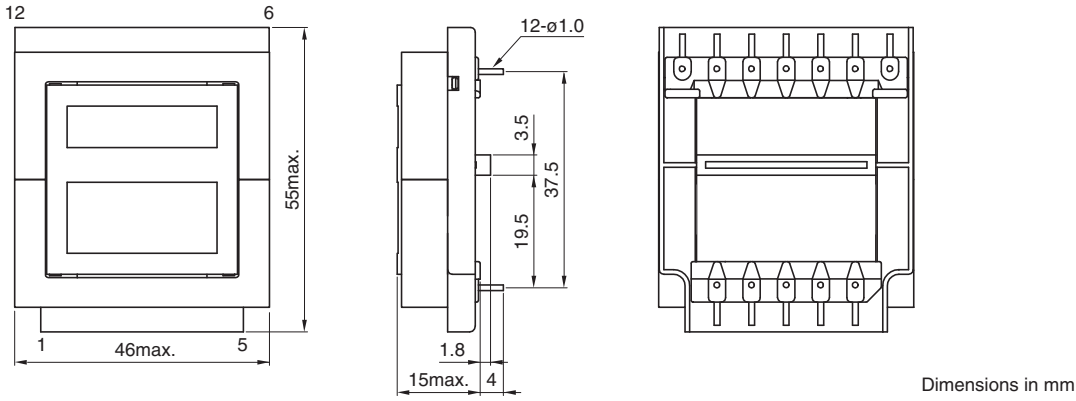

RECOMMENDED BASE MATERIAL OPENING SIZE

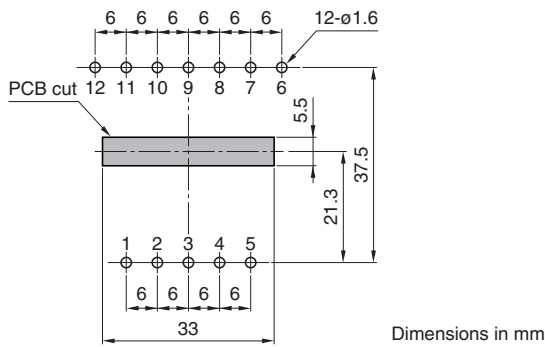

• All specifications are subject to change without notice.

SRX series

SRX25EM Type

SHAPE & DIMENSIONS

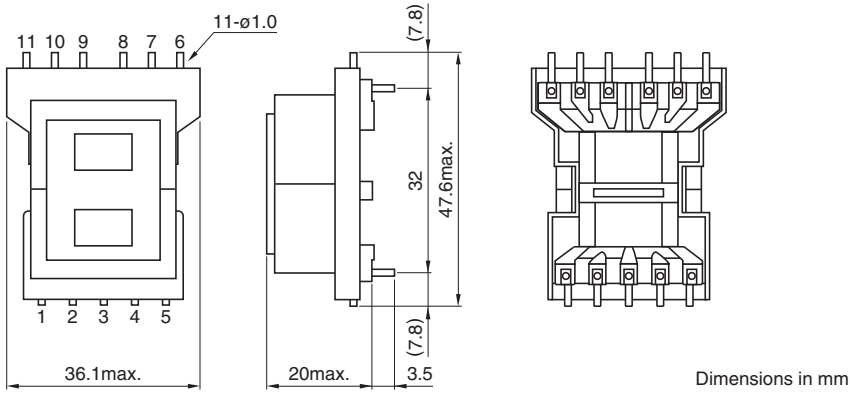

RECOMMENDED BASE MATERIAL OPENING SIZE

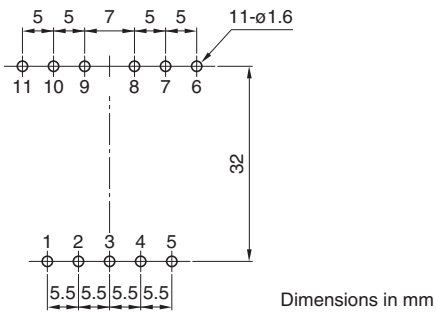

• All specifications are subject to change without notice.

SRX series

SRX30ER-I, SRX30ER-II Type

SHAPE & DIMENSIONS

SRX30ER-I

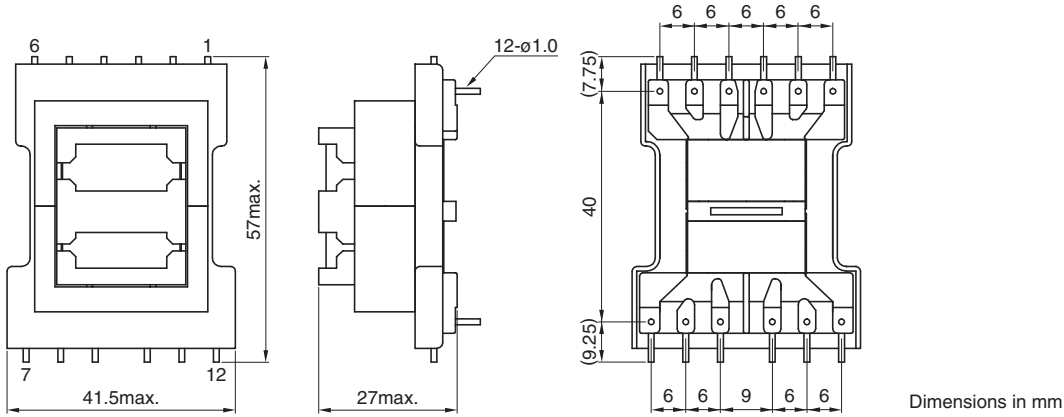

SRX30ER-II

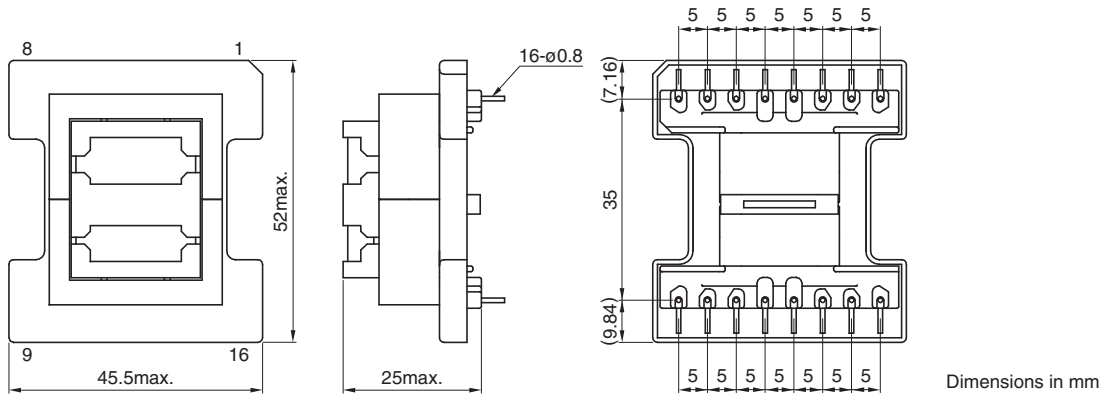

RECOMMENDED BASE MATERIAL OPENING SIZE

SRX30ER-I

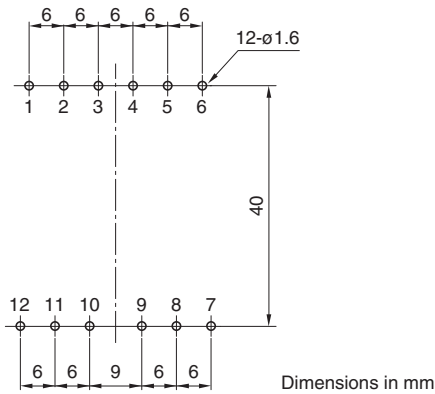

SRX30ER-II

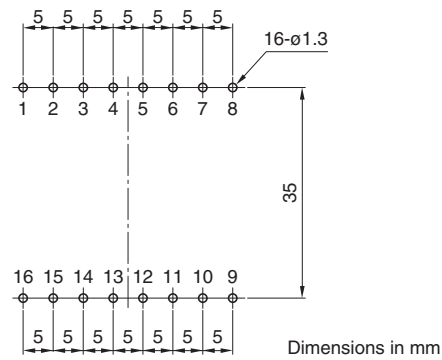

• All specifications are subject to change without notice.

SRX series

SRX48EM Type

SHAPE & DIMENSIONS

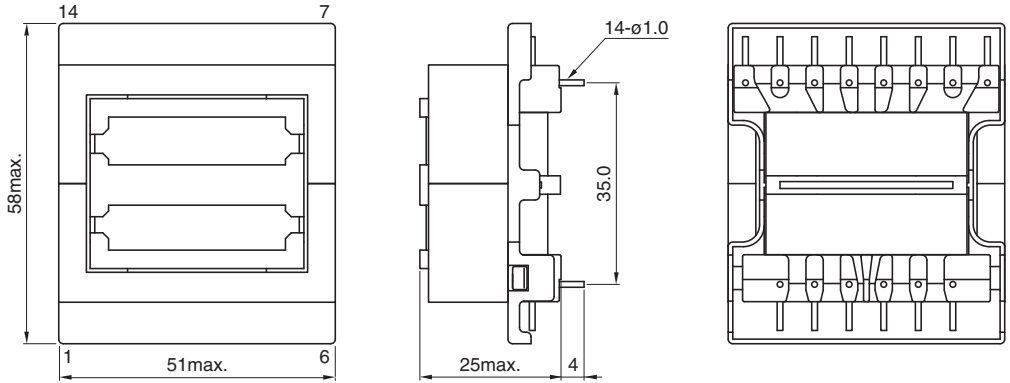

Dimensions in mm

RECOMMENDED BASE MATERIAL OPENING SIZE

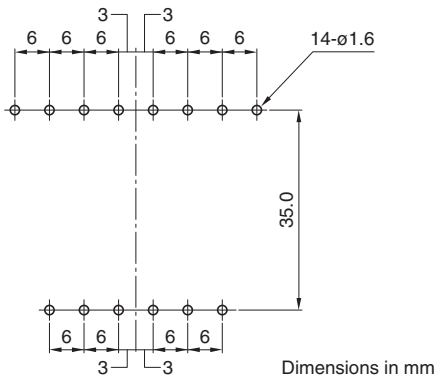

Dimensions in mm

• All specifications are subject to change without notice.

SRV series

SRV3914EE Type

SHAPE & DIMENSIONS

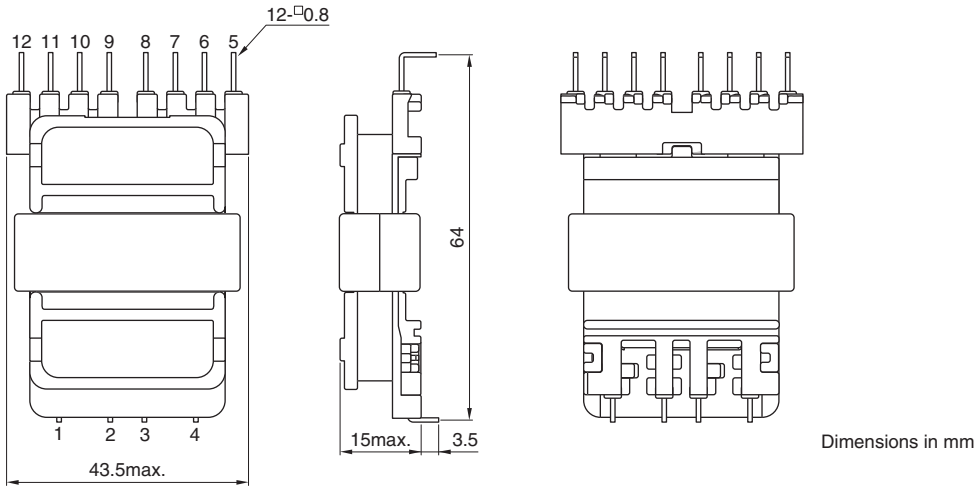

RECOMMENDED BASE MATERIAL OPENING SIZE

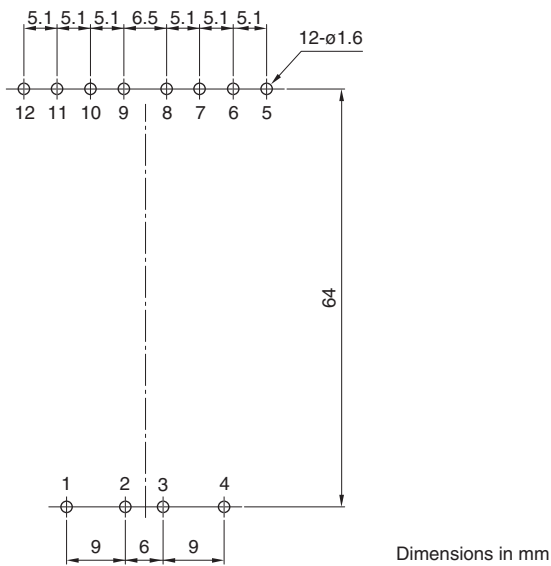

• All specifications are subject to change without notice.

SRV series

SRV4214EE Type

SHAPE & DIMENSIONS

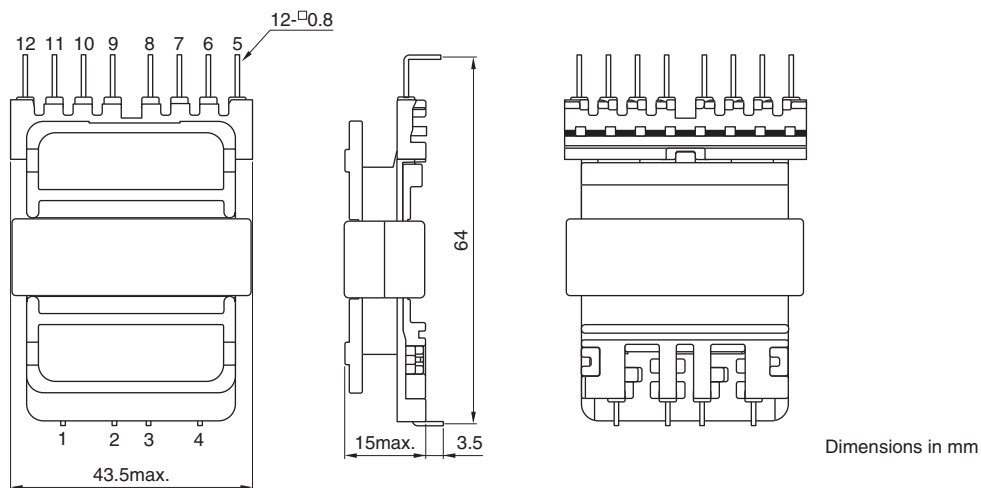

RECOMMENDED BASE MATERIAL OPENING SIZE

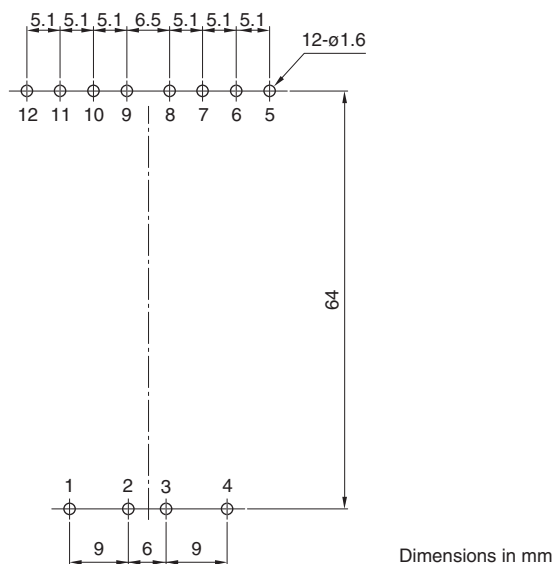

• All specifications are subject to change without notice.

SRV series

SRV4215ES Type

SHAPE & DIMENSIONS

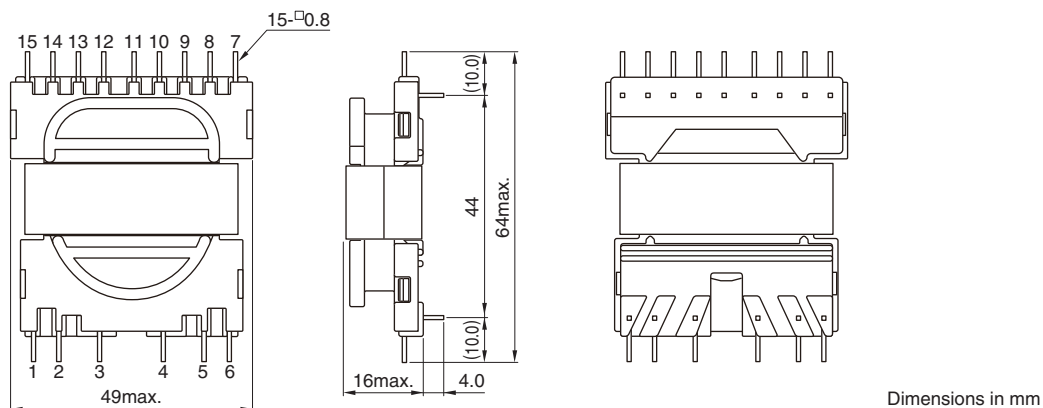

RECOMMENDED BASE MATERIAL OPENING SIZE

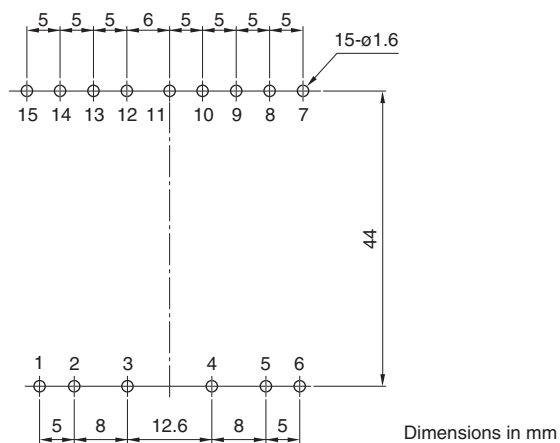

• All specifications are subject to change without notice.

SRV series

SRV4715ER Type

SHAPE & DIMENSIONS

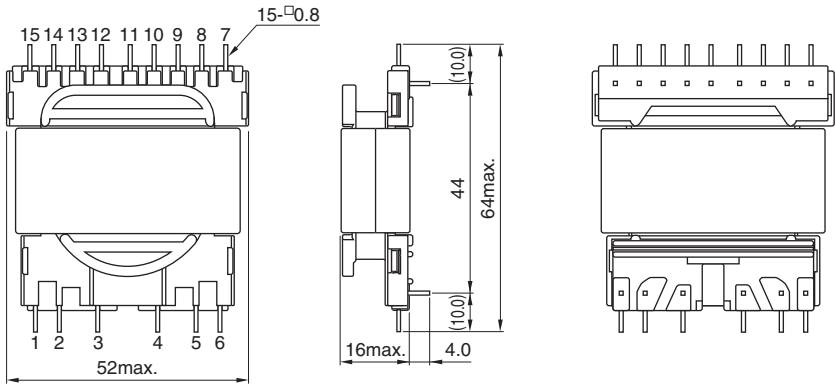

Dimensions in mm

RECOMMENDED BASE MATERIAL OPENING SIZE

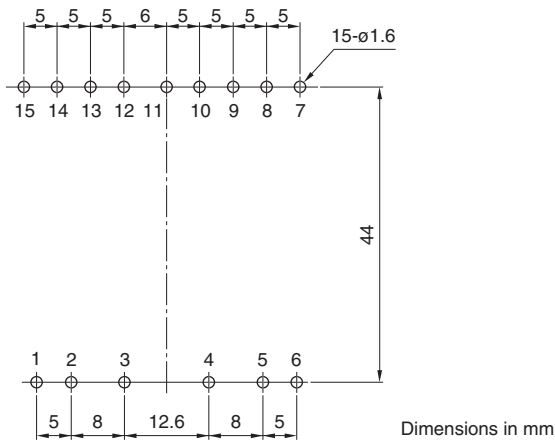

Dimensions in mm

• All specifications are subject to change without notice.

Design Material for LLC Resonance Power Transformers (Reference)

LLC RESONANT CONVERTER

The LLC resonant converter is a type of series resonant converter (SRC). It features low noise and high efficiency, and is a circuit system suitable for applications requiring a relatively large amount of power. Frequency modulation control (SFM) is used for control of the converter.

The converter is mainly driven in a half-bridge configuration. Because of the high core usage rate, low-loss core materials are recommended for downsizing of the converter.

The input voltage range of the LLC resonant converter is narrower than that of Pulse Width Modulation (PWM) converters, and it is normally recommended that a power factor correction (PFC) circuit be used for the front stage to stabilize input voltage. However, in recent years, control ICs supporting smoothing AC input have been proposed; in such cases, a transformer design that accommodates a wide input voltage range is believed to be the key factor.

As power transformer configurations, a method in which the converter is configured with a resonant inductor and a unity coupled transformer or a method using a leakage flux transformer exist. Generally, the latter product, which eliminates the need for an external resonance inductor, is often used.

Figure 1 Basic circuit (1) (with a separated resonance inductor)

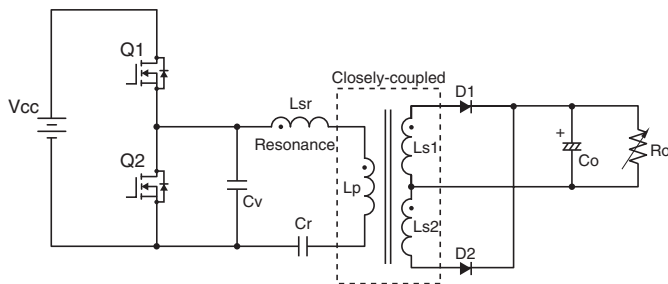
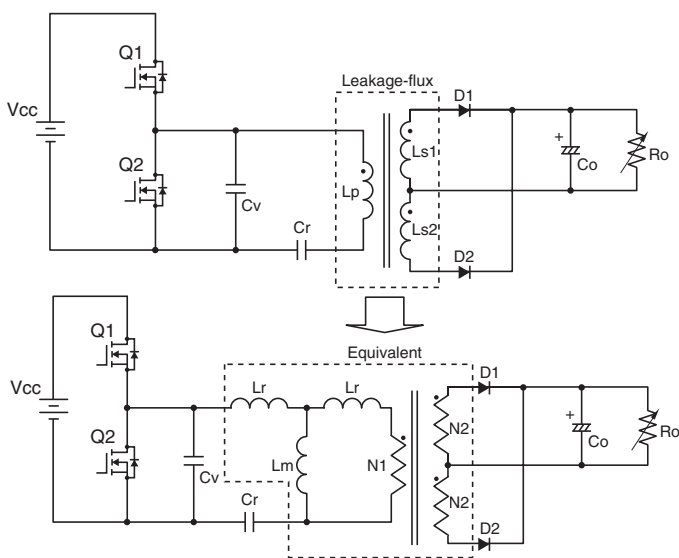

Figure 2 Basic circuit (2) (using a leakage flux transformer)



Here,

$$L_p = L_r + L_m \quad L_r = (1 - k) \times L_p \\ L_m = k \times L_p$$

- Lp: Primary inductance
- Lm: Excitation inductance
- Lr: Leakage inductance
- k: Coupling coefficient

LEAKAGE FLUX TRANSFORMER FOR LLC RESONANT CONVERTERS

In a leakage flux transformer, leakage inductance is intentionally increased and the inductance value is standardized. This characteristic is realized by physically separating Np and Ns. Here, the primary-side inductance when the secondary side is completely short-circuited is called the resonant inductance LLK. As the wire structure, the primary and secondary sides are separated by a wall to form split windings, decreasing the coupling. When the resonant inductance is denoted by LLK, the primary inductance by Lp, and the coupling coefficient by k, the following formula holds:

$$LLK = L_p \times (1 - k^2) \quad L_p = AL \times Np^2$$

AL denotes the inductance per turn.

OUTPUT VOLTAGE OF THE LLC RESONANT CIRCUIT

The LLC resonant circuit controls output voltage by changing the frequency using LC resonance. Approximate calculation of the output voltage can be performed using first harmonic approximation (FHA). Detailed information on the expansion method for the approximation formula will not be described in this paper. Please refer to technical books, etc., for more detailed information.

The following formula is obtained as the result of the expansion:

$$M = \frac{1}{\sqrt{\left(\frac{1}{k} \left(1 - \frac{1-k^2}{FR^2}\right)\right)^2 + \left(\frac{1}{k \cdot Q} \left(FR - \frac{1}{FR}\right)\right)^2}} \quad \dots(1)$$

$$FR = \frac{\omega}{\omega 0} \quad \omega 0 = \frac{1}{\sqrt{LLK \cdot Cr}} \quad \omega s = \frac{1}{\sqrt{Lp \cdot Cr}}$$

$$Z0 = \sqrt{\frac{LLK}{Cr}} \quad Q = \frac{Rac}{Z0} = \frac{8n^2}{\pi^2} \cdot \frac{R0}{Z0}$$

The angular frequency of the resonance between leakage inductance LLK and resonance capacitance Cr is ω0. When the above formula is expressed as a graph, it is clear that the circuit operates with ω0 as the base point.

Q is the ratio of load impedance to the characteristic impedance of LC resonant circuit Z0. It also expresses the degree of matching between them.

• All specifications are subject to change without notice.

When the load becomes lighter, Q becomes higher and the gain peak shifts to lower frequencies. However, it eventually becomes fs, the resonant frequency between the self-inductance of the primary winding Lp and Cr.

Figure 3 LLC resonant circuit normalized frequency characteristics

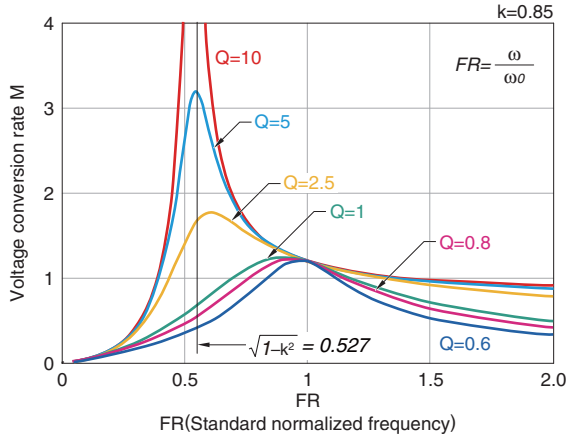

OPERATION POINT AND WAVEFORM

When the turn ratio of transformer n is considered, the input/output voltage can be expressed by the following formula, using M:

$$V_o = \frac{M V_{IN}}{2n} \quad FR = 2\pi f \sqrt{L_{LK} \cdot C_r} = \frac{f}{f_0}$$

From these formulas, Figure 3 can be converted into a graph of actual operation frequency-output voltage. Figure 4 shows a calculation example. The circuit operates at the "operation point" seen in the graph.

Figure 4 Frequency-output voltage characteristics

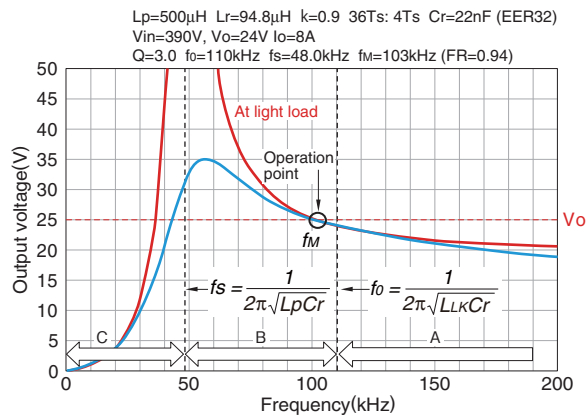

As shown in Figure 4, the operating range of the LLC resonant converter can be divided into three ranges by frequency. Among these ranges, Range C cannot be used. Therefore, transformers for LLC resonant power supplies are designed so that the operation point is located within Range A or B. Caution is required when locating the operation point in Range A, as the voltage change is not significant in this range.

Figure 5 shows the typical waveform in each range.

Figure 5 Operation waveform in each mode

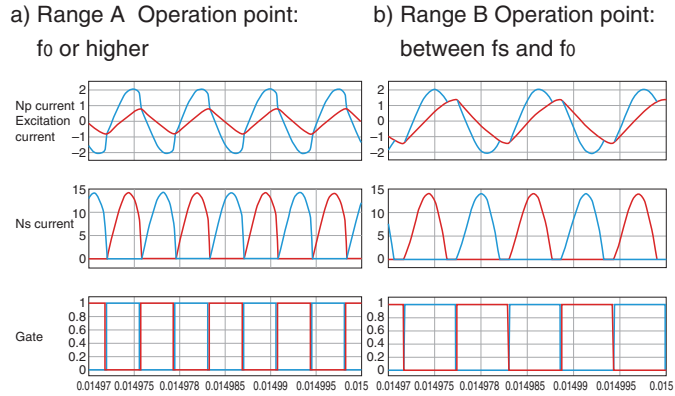

In Range A, load current flows continuously except at the zero-cross points. Conversely, in Range B, there are periods when load current does not flow. The boundary point is f=fo, and the input current almost forms a sine wave at this point.

Generally, operation points are designed to be in Range B or near the border between A and B. However, if the operation point is too close to fs, the number of periods in which no load current flows increases, causing the power factor to deteriorate and the peak current to increase. Since this will cause the effective current to increase, it is better to locate the operation point near fo to the extent possible in the steady-state condition.

If it is desired that the input current be closer to a sine wave, the operation point should be designed to be close to fo.

The operation point should ultimately be adjusted while checking the graph, so that the transformer operates even at the maximum and minimum input voltages.

CORE FLUX DENSITY AND CORE LOSS OF THE TRANSFORMER

Since the LLC resonant converter is a bridge circuit, the core is excited in two quadrants. For this reason, low-loss materials that decrease core loss are suitable for downsizing of the transformer. A rough calculation formula of Bm of the LLC resonant converter is shown in the following. The variation width of B is twice this. Core loss needs to be evaluated with this ΔB.

$$I_{PMAX} = \frac{V_o \times n}{4 \times k \times L_p \times f_o}$$

$$\Delta B = 2 \times B_m \quad B_m = \frac{L_p \times I_{PMAX}}{N_p \times A_e} \dots\dots(2)$$

- Vo: Output voltage
- n: Turn ratio
- k: Coupling coefficient
- Lp: Primary inductance
- Np: Primary number of turns
- Ae: Effective cross-sectional area
- fo: Resonance frequency

Figure 6 shows the temperature dependence of core loss in a common power ferrite material and TDK's low-loss material represented by PC47.

In an environment where the core temperature is 80°C or higher, the low-loss material has achieved a 20% or lower loss, which contributes to the temperature decrease and downsizing of the set.

• All specifications are subject to change without notice.

Figure 6 Example of temperature dependence of core loss

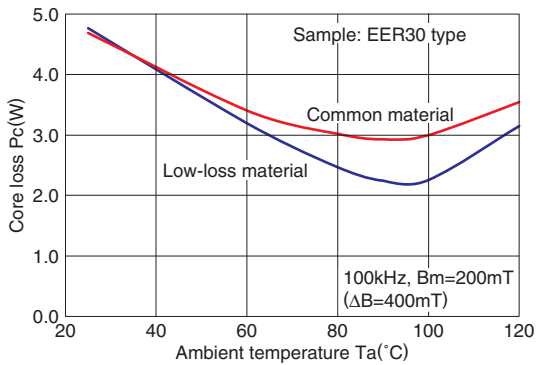

EXAMPLE OF TRANSFORMER DESIGN

The following is an example of transformer design. First, the specifications as a power supply is as follows: $V_{in}=350V$ to $405V$, $390V_{typ}$, $V_o=24V$, $I_o=8A$, $FR=1$ (critical mode) at around SW frequency $100kHz$.

As for other parameters:

$V_F=0.65V$, $k=0.9$, $Q=3$, EER32 core ($A_e=86.5\text{ mm}^2$)

V_F : drop voltage of the rectifier diode

1. Setting the operation point Voltage conversion rate M at the operation point is calculated.

Since $FR=1$ here, the following formula is used. When the operation point is changed, the value is calculated using Formula (1).

$$M_{(FR=1)} = \frac{1}{k}$$

2. Turn ratio n is determined from input voltage V_{in} and

$$n = \frac{V_{in} \cdot M}{2 \cdot (V_o + V_F)} = \frac{390}{2 \times 0.9 \times 24.65} = 8.79$$

3. AC equivalent resistance R_{ac} is calculated based on the maximum load condition.

$$R_{ac} = \frac{8 \cdot n^2}{\pi^2} \cdot R_L = \frac{8 \times 8.79^2}{3.1414^2} \times \frac{24}{8} = 187.9 [\Omega]$$

4. From the fact that R_{ac} is the characteristic impedance Z_o multiplied by Q , the value of Z_o is determined (the Q value is set based on referring to Figure 7. This value is dependent on coupling coefficient k). It is recommended that the value of Q be set to 3 or larger. It is set to 3 here. The Q value affects the number of turns.

$$Z_o = \frac{R_{ac}}{Q} = \frac{187.9}{3} = 62.63 [\Omega]$$

5. Calculation of C_r (resonance capacity) and L_{LK} (resonant inductance)

The values of L_{LK} and C_r are determined from the Z_o value calculated in the above process and the resonant frequency.

$$Z_o = \sqrt{\frac{L_{LK}}{C_r}} \quad f_o = \frac{1}{2\pi\sqrt{L_{LK} \cdot C_r}} \quad \text{From}$$

$$C_r = \frac{1}{2\pi Z_o f} = \frac{1}{2\pi \times 62.63 \times 100\text{kHz}} = 25.41 [\text{nF}]$$

$$L_{LK} = \frac{Z_o}{2\pi f} = \frac{62.63}{2\pi \times 100\text{kHz}} = 99.7 [\mu\text{H}]$$

6. Calculation of the primary inductance L_p and the number of turns of the transformer

In an EER32 core, $AL=386\text{ nH/n}^2$ when $k=0.9$ (this is a parameter determined by the transformer shape).

$$L_p = \frac{L_{LK}}{(1-k^2)} = \frac{99.7}{(1-0.9^2)} = 524.7 [\mu\text{H}]$$

$$N_p = \sqrt{\frac{L_p}{AL}} = \sqrt{\frac{524.7}{0.386}} = 36.87$$

$$N_s = \frac{N_p}{n} = \frac{37}{8.79} = 4.21$$

The first calculation is now complete. Adjustment will be performed after this. The values after the decimal point will first be rounded off since they cannot be wound. It is better for N_s with a smaller number of turns to be close to an integer.

The graph of Figure 4 (frequency-output voltage characteristic) is created to confirm the characteristic, and the core flux density is estimated using the Formula (2). The following points should be considered:

- Whether sufficient output can be obtained at the maximum/minimum input voltage and under the maximum/minimum load condition.
- If the flux density does not exceed 200mT. The flux density should be 250mT or smaller in a low-loss material.
- Confirmation of the operation point

For graph creation, the calculation is performed directly by using the formula of voltage conversion rate M or by using the AC analysis of the circuit simulator. It is recommended that the AC analysis graph be checked using one of these methods.

If problems are observed from the graph, calculation is performed again after modifying the design conditions. To be specific, Q and k (= Gap) will be adjusted. Particularly, when the voltage range or load condition is broad, it may be necessary to repeat this process several times to achieve the optimum conditions.

Figure 7 Normalized frequency characteristic at each k value

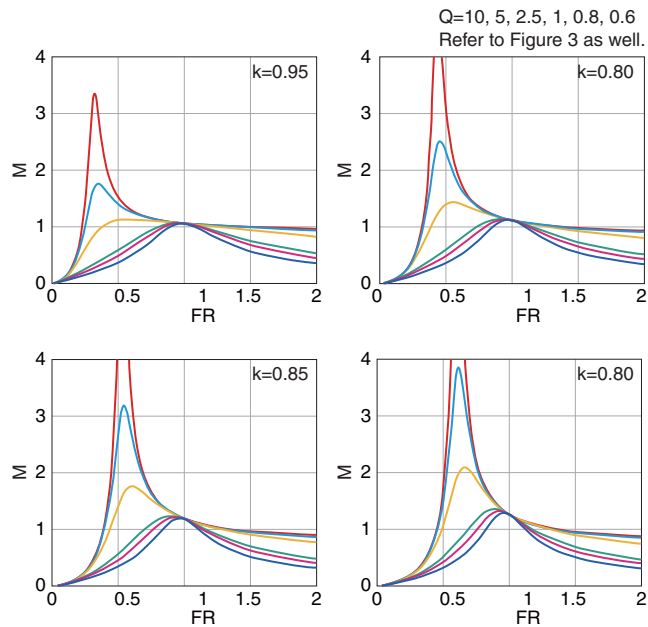

Final decision of transformer parameters

In the result obtained using the first calculation, there are fractions in the numbers of turns. These fractions will be corrected. To be specific, the fractions will be truncated or rounded up. Since the result here was 4.21Ts for N_s , it will be corrected to 4Ts.

Based on this modification, the calculation is performed in reverse order.

$$N_p = N_s \cdot n = 4 \times 8.79 = 35.2 \cong 35$$

$$L_p = A_L \cdot N_p^2 = 0.386 \times 35^2 = 473 \text{ } [\mu\text{H}]$$

$$L_{LK} = (1 - k^2)L_p = (1 - 0.9^2) \times 473 = 89.9 \text{ } [\mu\text{H}]$$

$$C_r = \frac{1}{(2\pi f)^2 L_{LK}} = \frac{1}{(2\pi \times 100\text{kHz})^2 89.9\mu\text{H}} = 28.2 \cong 27 \text{ } [\text{nF}]$$

$$Z_0 = \sqrt{\frac{L_{LK}}{C_r}} = \sqrt{\frac{89.9\mu}{27\text{n}}} = 57.7 \text{ } [\Omega]$$

$$Q = \frac{R_{ac}}{Z_0} = \frac{187.9}{57.7} = 3.26$$

$$f_0 = \frac{1}{2\pi \sqrt{L_{LK} \cdot C_r}} = 102 \text{ } [\text{kHz}]$$

AC analysis is performed using the modified parameters. Different voltage and load conditions are used as well.

Figure 8 AC analysis results

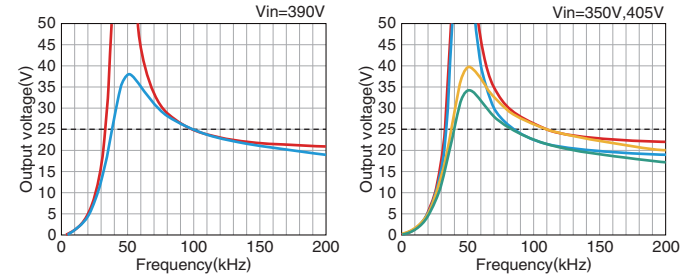

As there seems to be no problem in the output curves both at the maximum and minimum inputs, the design is considered to be okay. If more modification is desired, the above processes are repeated.

Estimation of the magnetic flux density will be performed.

$$I_{P\text{MAX}} = \frac{V_o \cdot n}{4 \cdot k \cdot L_p \cdot f_0} = \frac{24 \times 8.75}{4 \times 0.9 \times 473\mu \times 102\text{k}} = 1.21 \text{ } [\text{A}]$$

$$B_m = \frac{L_p \cdot I_{P\text{MAX}}}{N_p \cdot A_e} = \frac{473 \times 1.21}{35 \times 86.5} = 0.189 \text{ } [\text{T}]$$

The above is the reference procedure for transformer design.

We have compiled these design procedures in our original design tool to perform design.

It is also possible for us to suggest the most suitable transformer specifications for our customers, based on the contents provided in the LLC resonant Power Transformer Specification Request Form attached at the end of this document.

CHARACTERISTICS OF RESONANT TRANSFORMERS

A resonant transformer generally has a structure in which the primary and secondary windings are separated using a split bobbin (Figure 9). Through this structure, coupling is intentionally decreased to increase leakage inductance. The value of self-inductance significantly changes according to the core gap. However, leakage inductance does not change significantly according to the core gap changes (Refer to Figure 10). Therefore, when inductance is adjusted by the core gap, leakage inductance changes only slightly, even if self-inductance can be adjusted. When looking at coupling coefficient k , k is almost inversely proportional to the GAP value.

Figure 10 shows the characteristic example in the SRX35 type transformer.

Figure 9 Split winding structure

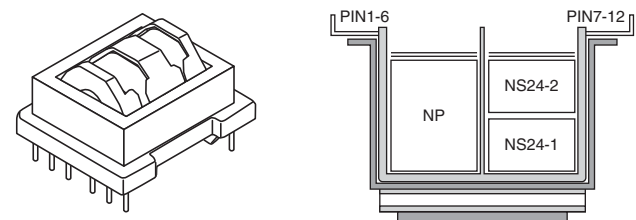

TRANSFORMERS

Figure 10 Core GAP vs. AL/k characteristic example of split windings (calculation value)

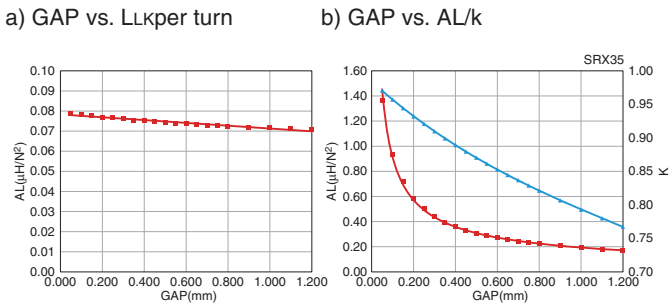

The number of turns is determined to some extent by the restrictions imposed by the magnetic flux density or output voltage ratio. Once the number of turns is determined, the leakage inductance becomes constant for the most part and cannot be changed by a large degree (for example, approximately 75nH/n² for SRX35).

This is a significant difference from the case in which a resonant inductor is externally attached.

When it is desired that the number of turns be changed, a winding method that does not use split windings can be used. However, this method is not recommended due to disadvantages in terms of production and cost.

WINDINGS

Since windings are formed using leakage flux alongside a large amount of AC component, strand wire is used to reduce loss by the skin effect or eddy current loss. Wire with a 0.1mm diameter or less is commonly used. Aside from normal strand wire, USTC wire that is covered by fiber is used. When this type of wire is used, windings do not become loose and adverse effects from winding collapse can be prevented.

TRANSIENT ANALYSIS BY A CIRCUIT SIMULATOR

Once the parameters are determined, it is recommended that transient analysis be performed using a circuit simulator, as it allows for accurate calculation of the transformer voltage and current as well as to check for any design errors. It is convenient to include the output voltage control function. The following is the calculation results of the sample design performed here.

Figure 11 Simulation result

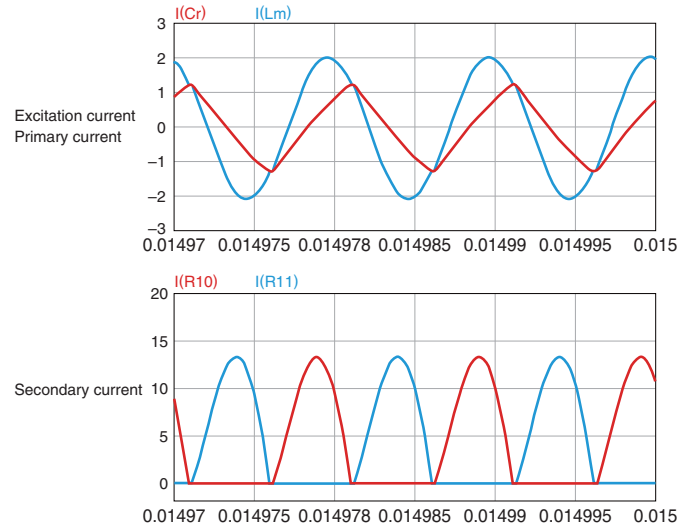

Vin=390V Vo=24V Io=8A
 Primary current: 1.27Ap '(199mT)
 SW frequency: 100.5kHz
 Primary current: 1.45A
 Secondary current: 6.48A

Figure 12 Simulation model

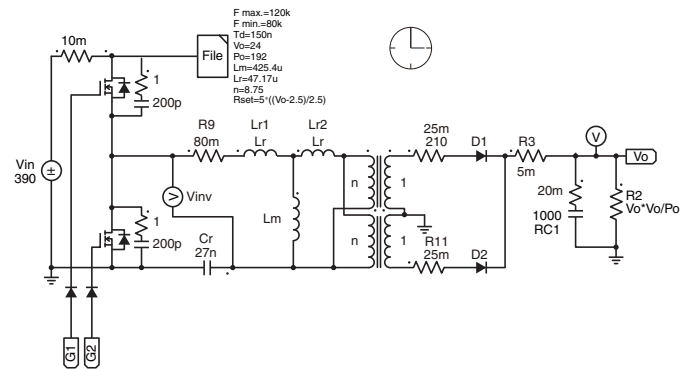

The frequency is almost exactly as designed.
 The operation waveforms are close to sine waves, and the operation point is at FR=1, as designed.
 From the current values, the necessary wire cross-sectional area can be estimated.

• All specifications are subject to change without notice.

REMINDERS

○ About multi-output transformers

The number of turns on the secondary side may only be a few turns in the design of a multi-output transformer. Even in such a case, multi-output is possible; however, it is difficult to output voltage that does not correspond to the turn ratio of the secondary side.

For example, when the winding is optimally designed with 4Ts at $V_o=24V$, the second output can only achieve $24/4=6V$ step voltage.

○ About multi-transformer configuration

When one transformer cannot achieve the necessary power due to shape restrictions, etc., combining multiple transformers with the same shape enables the required power to be achieved.

Contact us for more details on the transformer design method for each wire connection method.

○ About the impact of leakage flux

A common problem with thin resonant transformers is that, when the transformer has a structure in which metal plates, etc., are arranged close to each other on the upper and lower sides during operation, leakage flux generated from the transformer crosses through the metal and eddy current loss occurs. This may cause the metal plates or the transformer to generate heat. In such a case, it may become necessary to take measures such as redesigning the structure or providing magnetic shields, etc.

TRANSFORMERS

LLC Resonance Power Transformer Specification Request Form

Issued on _____ / _____ / _____

1. Company name _____

Address _____

2. Department, applicant's name

Name: _____

TEL/FAX : _____

E-mail : _____

| | |
|---|-------------------|
| Person in Charge from Sales Promotion Dep.: _____ | Recorded Date / / |
| Person in Charge from Sales Dep.: _____ | Recorded Date / / |
| Prototype No: _____ | Recorded Date / / |

3. Input specifications

AC input voltage: Rated _____ (V) to _____ (V) Operating range: _____ (V) to _____ (V)

DC input voltage: Rated _____ (V) to _____ (V) Operating range: _____ (V) to _____ (V)

Frequency _____ (Hz) Minimum operating input voltage: _____ (Hz)

4. Design condition

(1) Clock frequency Lowest frequency to Highest frequency: _____ to _____ (kHz)

| | | | |
|---|------------------------|------------------------|-----------|
| (2) Secondary-side output voltage _____ (V) ± _____ (V) | Min. | Typ. | Max. |
| | _____ (A) to _____ (A) | _____ (A) to _____ (A) | _____ (A) |
| | _____ (V) ± _____ (V) | _____ (A) to _____ (A) | _____ (A) |
| _____ (V) ± _____ (V) | _____ (A) to _____ (A) | _____ (A) | |

(3) Rated output power/Maximum peak power _____ (W) / _____ (W)

(4) Overcurrent point condition (ex.: 130% of the rated output power in (3) above) _____ (%)

(5) Operating temperature range _____ (°C) to _____ (°C)

(6) Maximum temperature rise ΔT _____ (°C)

Condition in temperature evaluation (ex.: minimum input, rated load) _____

(7) Auxiliary winding (Fill in the square like this) to make your selection. Yes No

Number of windings _____ (Windings)

Desired voltage value and current _____ (V) to _____ (mA)

Necessity of insulation (Fill in the square like this) to make your selection. Functional insulation Reinforced insulation

(8) Circuit diagram (If you desire any pin number, attach a circuit diagram.) Yes No

5. Inductance value for reference

Primary-side self-inductance: _____ μ(H) Leakage inductance: _____ μ(H)

6. Desired core size and external size

Core size: _____ External size L: _____ W: _____ H(Height from the board): _____ mm max.

7. Safety standard compliance

Electrical Appliances and Material Safety Act, Appendix 8 CSA _____ Others _____

UL _____ IEC _____

Application for the transformer Yes* Set purchase No (* Please bear in mind that the application fee may be borne by the customer.)

Insulation type Basic insulation Reinforced insulation Double insulation Other (_____)

Pollution degree 1 2 3 (If not specified, design will be performed with a pollution degree of 2.)

8. Safety distance (Please enter the distance prescribed by the company.)

Primary - secondary: _____ mm or greater Primary - primary: _____ mm or greater Primary - core: _____ mm or greater

Secondary - secondary: _____ mm or greater Secondary - core: _____ mm or greater

9. Withstand voltage (Please enter the voltage prescribed by the company.)

Primary - secondary: AC _____ (V) _____ (min) _____ (mA) Primary - core: AC _____ (V) _____ (min) _____ (mA)

Primary - primary: AC _____ (V) _____ (min) _____ (mA) Secondary - core: AC _____ (V) _____ (min) _____ (mA)

Secondary - secondary: AC _____ (V) _____ (min) _____ (mA)

10. IC expected to be used

Manufacturer name: _____ Product No.: _____

11. Production quantity information

Final set name: _____ Desired price/Currency: _____

Acceptance conditions of the above price (F.O.B, C.I.F, D.D.U, D.D.P etc.): _____

Production volume: _____ k/M Production start period: _____ Production place: _____

Prototyping time: (ES1) _____ (ES2) _____ (PP1) _____ (PP2) _____ (MP1) _____

12. Sample information

Required sample quantity _____ pcs. Requested delivery time: _____

13. If there are any other requests (priorities in the company, size or price, etc.) or alterable items, please provide a description.

TDK-EPC Corporation Magnetics Business Group, Business Promotions Dept.
3-9-1, Shibaura, Minato-ku Tokyo 108-0023, Japan TEL: 81-3-6852-7229, FAX: 81-3-6852-7159

• All specifications are subject to change without notice.