

### Description

The ST0521D4 is a bi-directional TVS diode, utilizing leading monolithic silicon technology to provide fast response time and low ESD clamping voltage, making this device an ideal solution for protecting voltage sensitive high-speed data lines. The ST0521D4 has an ultra-low capacitance with a typical value at 0.26pF, and complies with the IEC 61000-4-2 (ESD) standard with  $\pm 15\text{kV}$  air and  $\pm 8\text{kV}$  contact discharge. It is assembled into an ultra-small 1.0x0.6x0.5mm lead-free DFN package. The small size, ultra-low capacitance and high ESD surge protection make ST0521D4 an ideal choice to protect cell phone, digital video interfaces and other high speed ports.

### Features

- ◆ Ultra small package: 1.0x0.6x0.5mm
- ◆ Ultra low capacitance: 0.26pF typical
- ◆ Ultra low leakage: nA level
- ◆ Low operating voltage: 5V
- ◆ Low clamping voltage
- ◆ 2-pin leadless package
- ◆ Complies with following standards:
  - IEC 61000-4-2 (ESD) immunity test  
Air discharge:  $\pm 20\text{kV}$   
Contact discharge:  $\pm 15\text{kV}$
  - IEC61000-4-4 (EFT) 40A (5/50ns)
  - IEC61000-4-5 (Lightning) 4A (8/20 $\mu\text{s}$ )
- ◆ RoHS Compliant

### Mechanical Characteristics

- ◆ Package: DFN1006-2
- ◆ Lead Finish: NiPdAu
- ◆ Case Material: “Green” Molding Compound.
- ◆ UL Flammability Classification Rating 94V-0
- ◆ Moisture Sensitivity: Level 3 per J-STD-020
- ◆ Terminal Connections: See Diagram Below
- ◆ Marking Information: See Below

### Applications

- ◆ Cellular Handsets and Accessories
- ◆ Display Ports
- ◆ MDDI Ports
- ◆ USB Ports
- ◆ Digital Video Interface (DVI)
- ◆ PCI Express and Serial SATA Ports

### Ordering Information

Part Number	Packaging	Reel Size
ST0521D4	10000/Tape & Reel	7 inch

### Dimensions

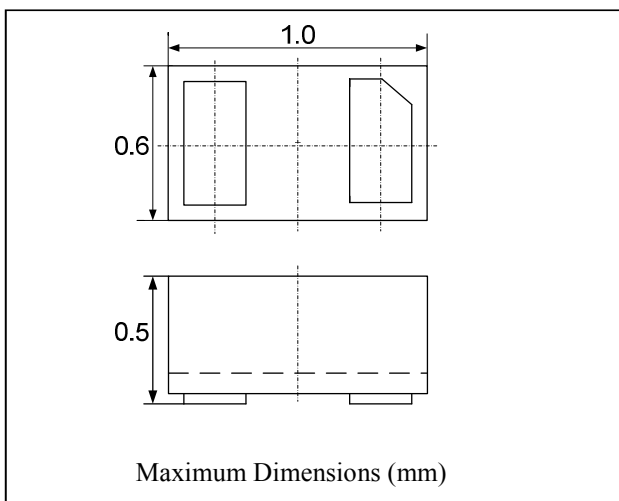

### Schematic and PIN Configuration

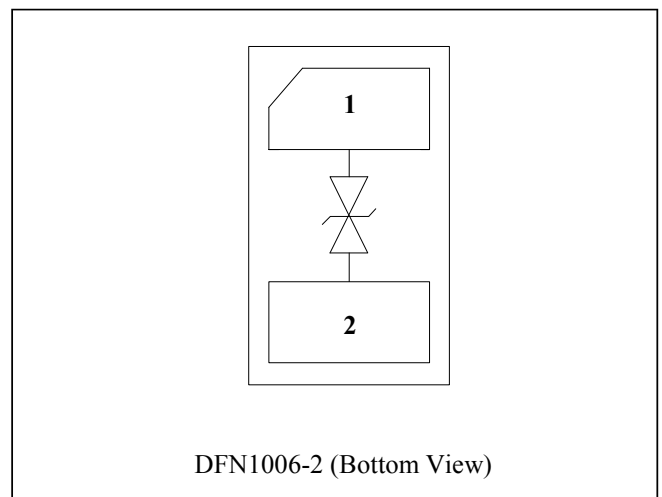

**Absolute Maximum Ratings (TA=25°C unless otherwise specified)**

Parameter	Symbol	Value	Unit
Peak Pulse Power (8/20μs)	Ppk	100	W
Peak Pulse Current (8/20μs)	IPP	4	A
ESD per IEC 61000-4-2 (Air)	VESD	±20	kV
ESD per IEC 61000-4-2 (Contact)		±15	
Operating Temperature Range	TJ	-55 to +125	°C
Storage Temperature Range	Tstg	-55 to +150	°C

**Electrical Characteristics (TA=25°C unless otherwise specified)**

Parameter	Symbol	Min	Typ	Max	Unit	Test Condition
Reverse Working Voltage	VRWM			5	V	
Breakdown Voltage	VBR	5.4		9	V	IT = 1mA
Reverse Leakage Current	IR			0.5	uA	VRWM = 5V
Clamping Voltage	VC			12	V	IPP = 1A (8 x 20μs pulse)
Clamping Voltage	VC			25	V	IPP = 4A (8 x 20μs pulse)
Junction Capacitance	CJ		0.26	0.35	pF	VR = 0V, f = 1MHz

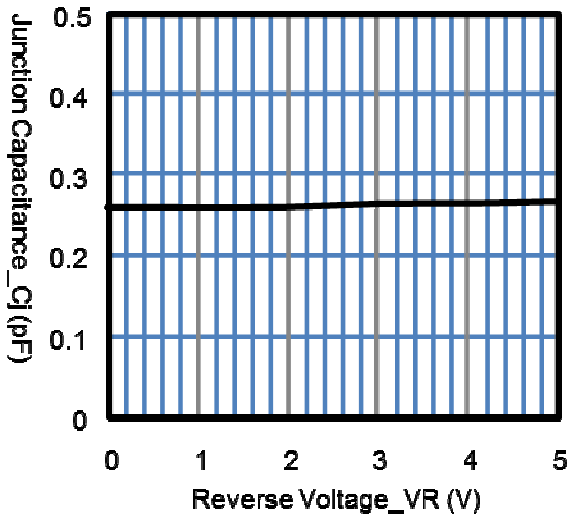
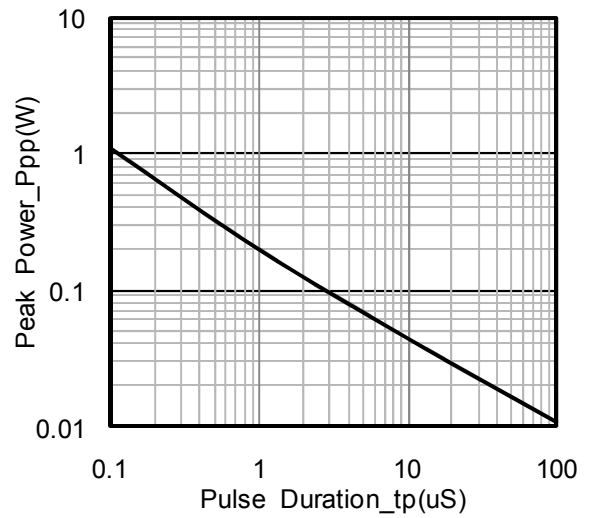
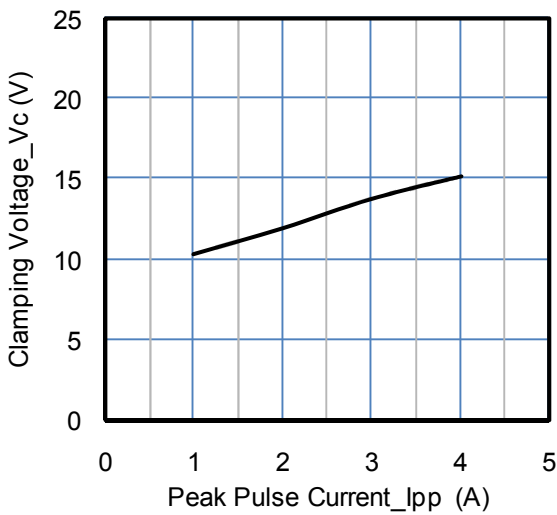
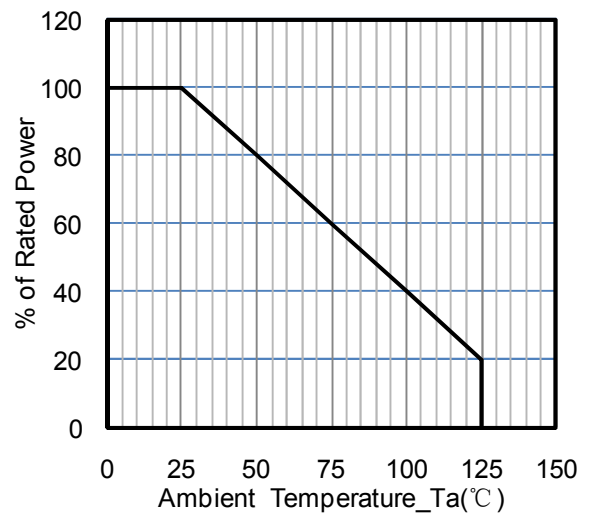
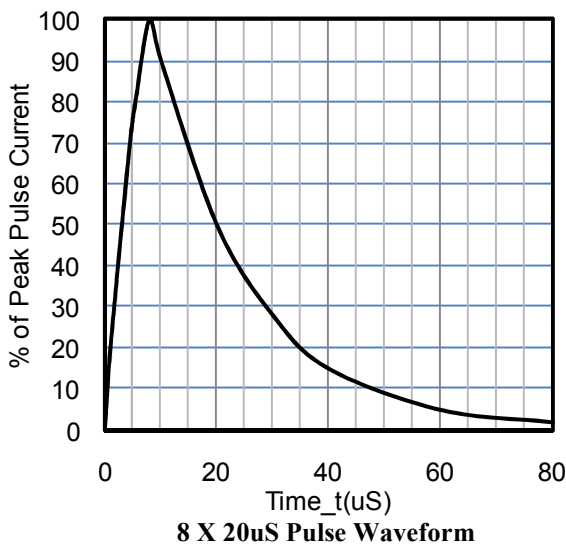
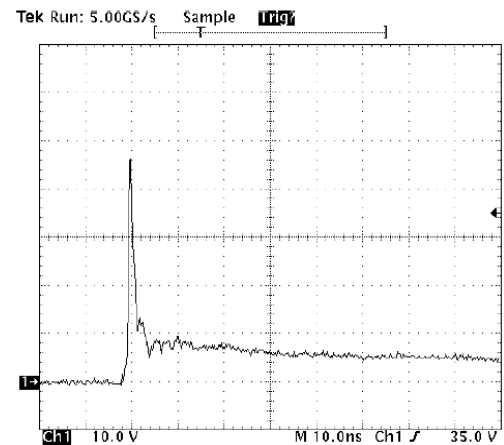
**Typical Performance Characteristics (TA=25°C unless otherwise specified)**

**Junction Capacitance vs. Reverse Voltage**

**Peak Pulse Power vs. Pulse Time**

**Clamping Voltage vs. Peak Pulse Current**

**Power Derating Curve**

**8 X 20uS Pulse Waveform**

**ESD Clamping Voltage**
**8 kV Contact per IEC61000-4-2**

## Applications Information

### Device Connection Options

These low capacitance TVS diodes are designed to provide common mode protection for one high-speed line or differential protection for one line pair. The device is bidirectional and may be used on lines where the signal polarity is positive and negative.

### Circuit Board Layout Recommendations for Suppression of ESD

Good circuit board layout is critical for the suppression of ESD induced transients. The following guidelines are recommended:

- ◆ Place the TVS near the input terminals or connectors to restrict transient coupling.
- ◆ Minimize the path length between the TVS and the protected line.
- ◆ Minimize all conductive loops including power and ground loops.
- ◆ The ESD transient return path to ground should be kept as short as possible.
- ◆ Never run critical signals near board edges.
- ◆ Use ground planes whenever possible.

### Equivalent Circuit Diagram

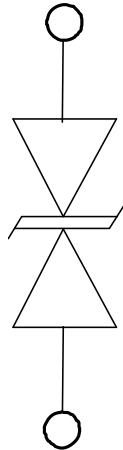

## DFN1006-2 Package Outline Drawing

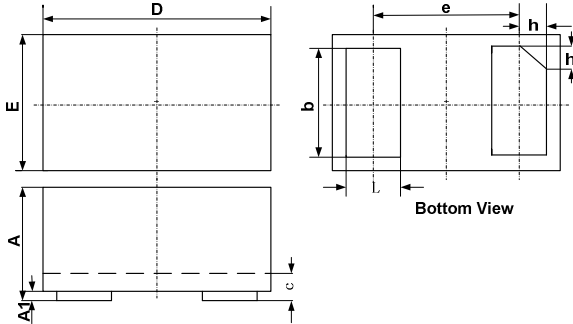

SYM	DIMENSIONS					
	MILLIMETERS			INCHES		
	MIN	NOM	MAX	MIN	NOM	MAX
A	0.45	0.50	0.55	0.018	0.020	0.022
A1	0.00	0.02	0.05	0.000	0.001	0.002
b	0.45	0.50	0.55	0.018	0.020	0.022
c	0.12	0.15	0.18	0.005	0.006	0.007
D	0.95	1.00	1.05	0.037	0.039	0.041
e	0.65 BSC			0.026 BSC		
E	0.55	0.60	0.65	0.022	0.024	0.026
L	0.20	0.25	0.30	0.008	0.010	0.012
h	0.07	0.12	0.17	0.003	0.005	0.007

## Suggested Land Pattern

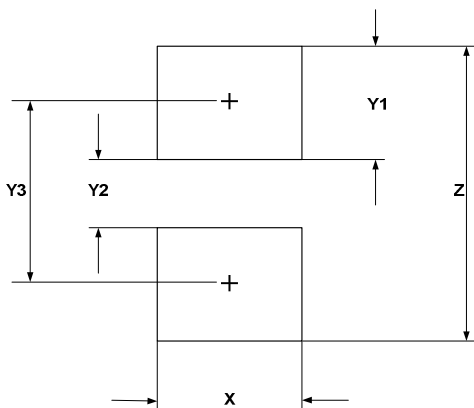

SYM	DIMENSIONS	
	MILLIMETERS	INCHES
X	0.60	0.024
Y1	0.50	0.020
Y2	0.30	0.012
Y3	0.80	0.032
Z	1.30	0.052

## Contact Information

Sursemi Technologies, Inc.

396 Arbor Court, Simi Valley, CA 93065

Phone: (805) 402-0326 Email: sales@sursemi.com