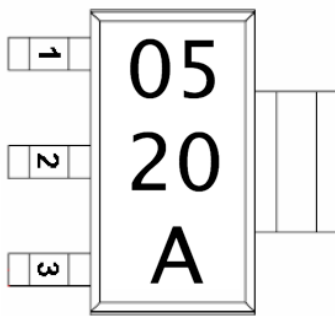

DESCRIPTION

ST05N20 is the N-Channel logic enhancement mode power field effect transistor which is produced using high cell density, DMOS trench technology. This high density process is especially tailored to minimize on-state resistance. These devices are particularly suited for low voltage application such as power management and other battery powered circuits where high-side switching.

**PIN CONFIGURATION
SOT-223**

0520 : Product Code
A : Date Code

FEATURE

- 200V/2.0A, $R_{DS(ON)} = 800m\Omega$ @ $V_{GS} = 10V$
- Super high density cell design for extremely low $R_{DS(ON)}$
- Exceptional on-resistance and maximum DC current capability
- SOT-223 package design

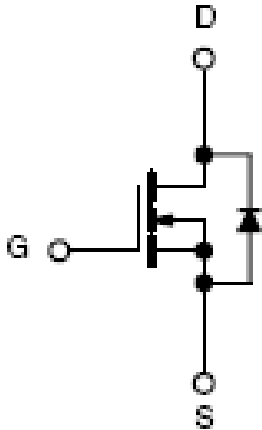

ABSOLUTE MAXIMUM RATINGS (Ta = 25°C Unless otherwise noted)

Parameter	Symbol	Typical	Unit
Drain-Source Voltage	VDSS	200	V
Gate-Source Voltage	VGSS	±30	V
Continuous Drain Current (TJ=150°C)	ID	TA=25°C 2	A
		TA=100°C 0.8	
Pulsed Drain Current	IDM	10	A
Repetitive Avalanche Current	EAS	4.2	mJ
Power Dissipation	TA=25°C PD	1.78	W
Operation Junction Temperature	TJ	-55/150	°C
Storage Temperature Range	TSTG	-55/150	°C
Thermal Resistance-Junction to Ambient	RθJA	75	°C/W

ELECTRICAL CHARACTERISTICS (Ta = 25°C Unless otherwise noted)

Parameter	Symbol	Condition	Min	Typ	Max	Unit
Static						
Drain-Source Breakdown Voltage	$V_{(BR)DSS}$	$V_{GS}=0V, I_D=250\mu A$	200			V
Gate Threshold Voltage	$V_{GS(th)}$	$V_{DS}=V_{GS}, I_D=250\mu A$	3	4	5	V
Gate Leakage Current	I_{GSS}	$V_{DS}=0V, V_{GS}=\pm 30V$			± 100	nA
Zero Gate Voltage Drain Current	I_{DSS}	$V_{DS}=160V, V_{GS}=0V$			1	μA
Drain-source On-Resistance	$R_{DS(on)}$	$V_{GS}=10V, I_D=12A$		750	800	m Ω
Forward Transconductance	gfs	$V_{DS}=10V, I_D=2A$		3.6		S
Diode Forward Voltage	V_{SD}	$I_S=1A, V_{GS}=0V$			1	V
Dynamic						
Total Gate Charge	Q_g	$V_{DS}=160V, V_{GS}=10V$ $I_D=1 A$			9	nC
Gate-Source Charge	Q_{gs}				4	
Gate-Drain Charge	Q_{gd}				2	
Input Capacitance	C_{iss}	$V_{DS}=25V, V_{GS}=0V$ $f=1MHz$		260	500	pF
Output Capacitance	C_{oss}			160	300	
Reverse Transfer Capacitance	C_{rss}			55	110	
Turn-On Time	$t_{d(on)}$ t_r	$V_{DS}=100$ $V_{GEN}=10V, I_D=1A$ $R_G=25\Omega$		10	20	nS
Turn-Off Time	$t_{d(off)}$ t_f			35	70	
				10	20	
			28	56		

TYPICAL CHARACTERISTICS

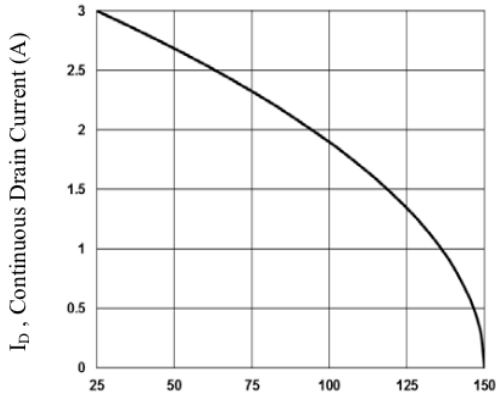

Fig.1 Continuous Drain Current vs. T_c

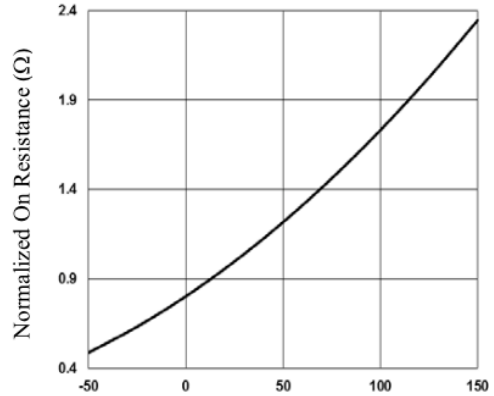

Fig.2 Normalized $R_{DS(on)}$ vs. T_j

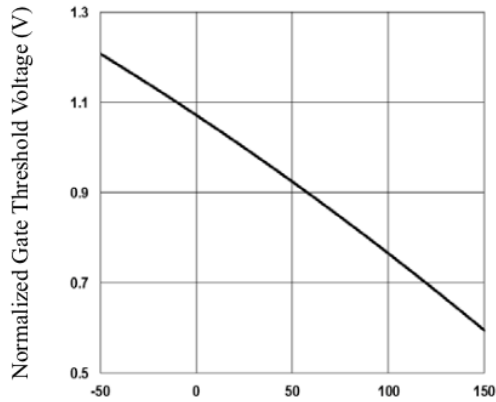

Fig.3 Normalized V_{th} vs. T_j

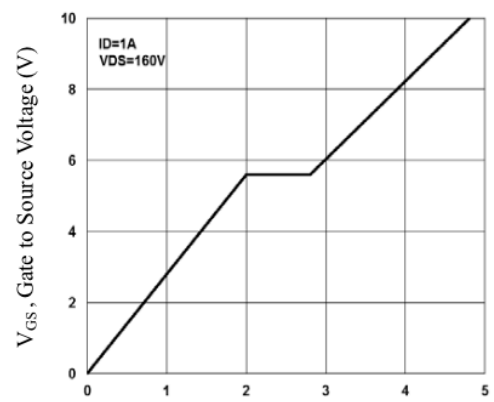

Fig.4 Gate Charge Waveform

TYPICAL CHARACTERISTICS

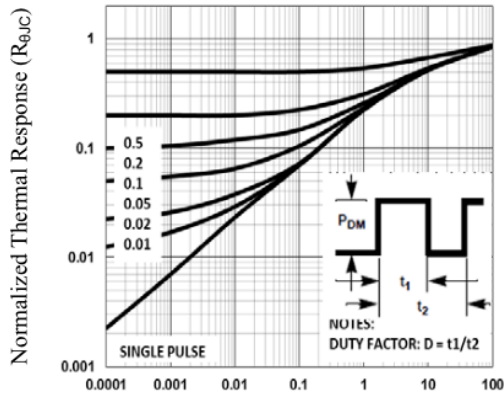

Fig.5 Normalized Transient Impedance

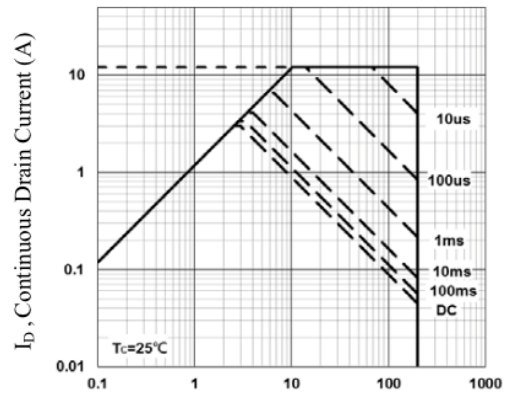

Fig.6 Maximum Safe Operation Area

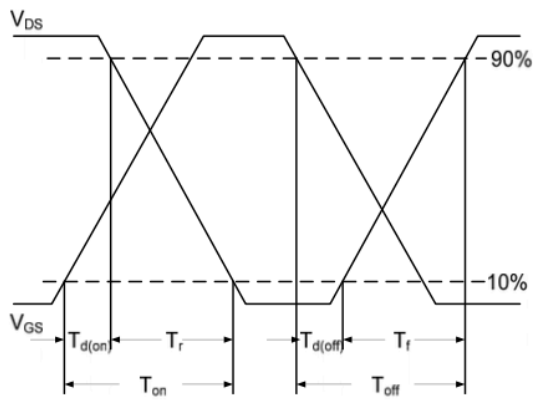

Fig.7 Switching Time Waveform

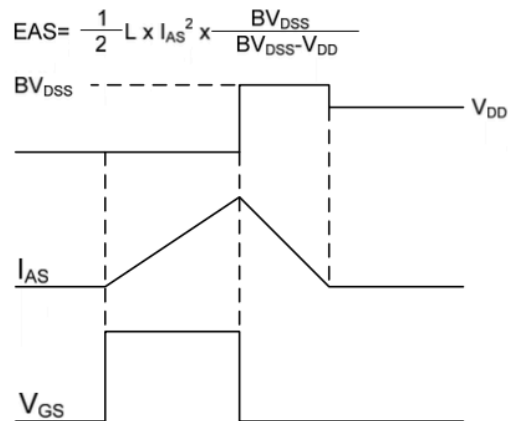
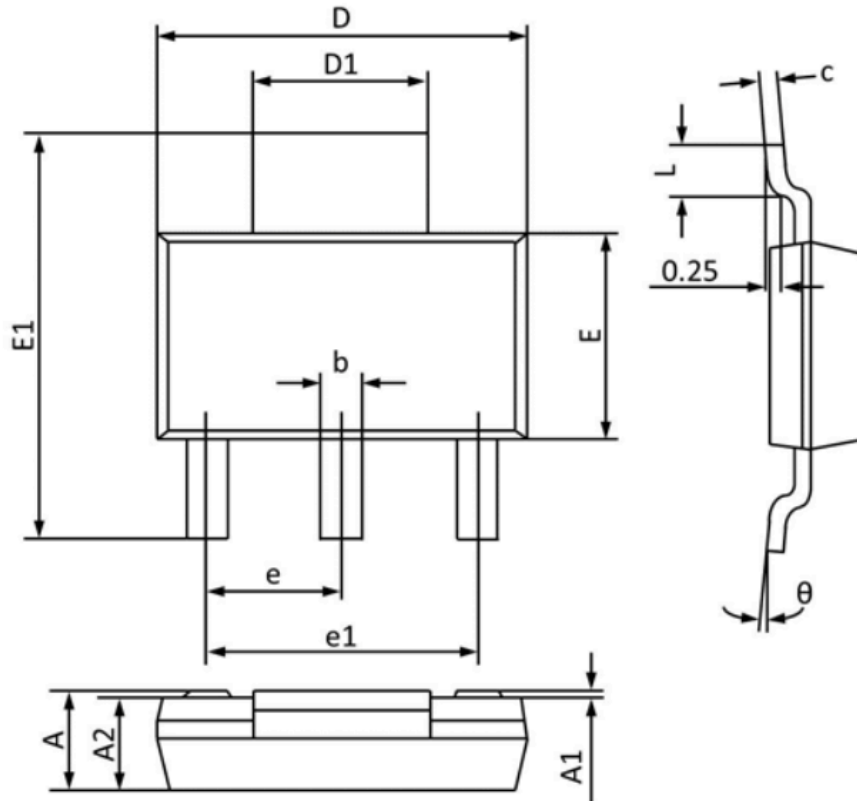

Fig.8 EAS Waveform

PACKAGE OUTLINE SOT-223

Symbol	Dimensions In Millimeters		Dimensions In Inches	
	Min	Max	Min	Max
A	1.520	1.800	0.060	0.071
A1	0.000	0.100	0.000	0.004
A2	1.500	1.700	0.059	0.067
b	0.660	0.820	0.026	0.032
c	0.250	0.350	0.010	0.014
D	6.200	6.400	0.244	0.252
D1	2.900	3.100	0.114	0.122
E	3.300	3.700	0.130	0.146
E1	6.830	7.070	0.269	0.278
e	2.300 (BSC)		0.091 (BSC)	
e1	4.500	4.700	0.177	0.185
L	0.900	1.150	0.035	0.045
θ	0°	10°	0°	10°