



# **Service Manual**

## **LCD Monitor ST2010**

**Service Manual Versions and Revision**

<b>No.</b>	<b>Version</b>	<b>Release Date</b>	<b>Revision</b>
1	1.0	2009/02/11	Initial Release

**Copyright**

Copyright 2007 InnoLux Display. Corp. Ltd

All Rights Reserved

This manual may not, in whole or in part, be copied, Photocopied, reproduced, translated, or converted electronic or machine readable form without prior written permission of Foxconn Tech. Corp. Ltd.

**Dell ST2010 Service Manual**



## Table of Contents

<b>CHAPTER 1- PRECAUTIONS &amp; SAFETY NOTICES.....</b>	
SAFETY PRECAUTIONS .....	
PRODUCT SAFETY NOTICE.....	
SERVICE NOTES .....	
<b>CHAPTER 2- SERVICE TOOLS &amp; EQUIPMENT REQUIRED .....</b>	
<b>CHAPTER 3- CIRCUIT THEORY .....</b>	
1.BLOCK DIAGRAM .....	
2.ELECTRONIC CIRCUIT THEORY .....	
3. FACTORY PRESET TIMING TABLE .....	
4. POWER ON/OFF SEQUENCY .....	
5. D-SUB CONNECTOR PIN ASSIGNMENT.....	
6. AC OUTLET PIN ASSIGNMENT .....	
7. INNER CONNECTOR PIN ASSIGNMENT.....	
8. KEY PARTS PIN ASSIGNMENTS .....	
<b>CHAPTER 4- DISASSEMBLY &amp; ASSEMBLY.....</b>	
1. EXPLODED DIAGRAM.....	
2. ST2010 DISASSEMBLY BLOCK .....	
3. ST2010 ASSEMBLY BLOCK.....	
<b>CHAPTER 5- TEST AND ADJUSTMENT.....</b>	
5.1 FUNCTION KEY DEFINITIONS.....	
5.2 OSD CONTROL.....	
5.3 OSD MESSAGE .....	
5.4 BURN-IN PATTERN .....	
5.5 AUTO COLOR BALANCE (AUTOMATICALLY CALIBRATE CHIP ADC PARAMETER BY USING CHIP INTERNAL DAC.) .....	
5.6 UPGRADE FIRMWARE TO SERIAL VIA FLASH CABLE BY ISP_TOOL V4.100.EXE .....	
<b>CHAPTER 6- TROUBLE SHOOTING .....</b>	
1. COMMON ACKNOWLEDGE .....	
2. NO POWER SUPPLY .....	
3. POWER (INCLUDE IF +5VAND +3.3V) SUPPLY NORMAL BUT LED OFF AND NO DISPLAY .....	
4. POWER (INCLUDE IF +5VAND +3.3V) SUPPLY AND DISPLAY NORMAL ONLY LED OFF.....	
5. POWER (INCLUDE IF +5VAND +3.3V) SUPPLY NORMAL BUT LED AMBER .....	
6. POWER (INCLUDE IF +5VAND +3.3V) SUPPLY NORMAL ,KEY FUNCTION OK,BUT BACKLIGHT CAN'T BE TURNED ON .....	
7. BACKLIGHT ON,KEY FUNCTION AND LED ACCURATE INDICATION OK BUT NO PICTURE.....	
8. AT 32-GRAY SCALE PATTERN, COLOR LOST IN SOME SCALE.....	
<b>CHAPTER 7- RECOMMENDED PART LIST .....</b>	
<b>ATTACHMENT 1- BILL OF MATERIAL .....</b>	
<b>ATTACHMENT 2- SCHEMATIC .....</b>	
<b>ATTACHMENT 3- PCB LAYOUT.....</b>	

## **Chapter 1- PRECAUTIONS & SAFETY NOTICES**

### **SAFETY PRECAUTIONS**

This monitor is manufactured and tested on a ground principle that a user's safety comes first. However, improper used or installation may cause damage to the monitor as well as to the user.

#### **WARNINGS:**

- This monitor should be operated only at the correct power sources indicated on the rating label on the rear cover of the monitor. If you're unsure the power supply in your residence, consult your local dealer or Power Company.
- Use only the specified power cord that comes with this monitor.
- Do not try to repair the monitor by yourself, as it contains no user-serviceable parts. This monitor should only be repaired by a qualified technician.
- Do not remove the monitor cabinet. There is high-voltage parts inside that may cause electric shock to human bodies.
- Stop using the monitor if the cabinet is damaged. Have it checked by a service technician.
- Put your monitor only in a lean, cool, dry environment. If it gets wet, unplug the power cable immediately and consult your closed dealer.
- Always unplug the monitor before cleaning it. Clean the cabinet with a clean, dry cloth. Apply non-ammonia based cleaner onto the cloth, not directly onto the class screen.
- Do not place heavy objects on the monitor or power cord.

### **PRODUCT SAFETY NOTICE**

Many electrical and mechanical parts in this chassis have special safety visual inspections and the protection afforded by them cannot necessarily be obtained by using replacement components rated for higher voltage, wattage, etc. Before replacing any of these components read the parts list in this manual carefully. The use of substitute replacement parts, which do not have the same safety characteristics as specified in the parts list, may create shock, fire, or other hazards.

### **SERVICE NOTES**

- When replacing parts on circuit boards, clamp the solder wires around terminals before soldering.
- Keep wires away from high voltage, high temperature components and sharp edges.
- Keep wires in their original position so as to reduce interference.
- Adjustment of this product please refers to the user' manual.
- Use Pb free solder wire for circuit board preparation.



---

## **Service Manual**

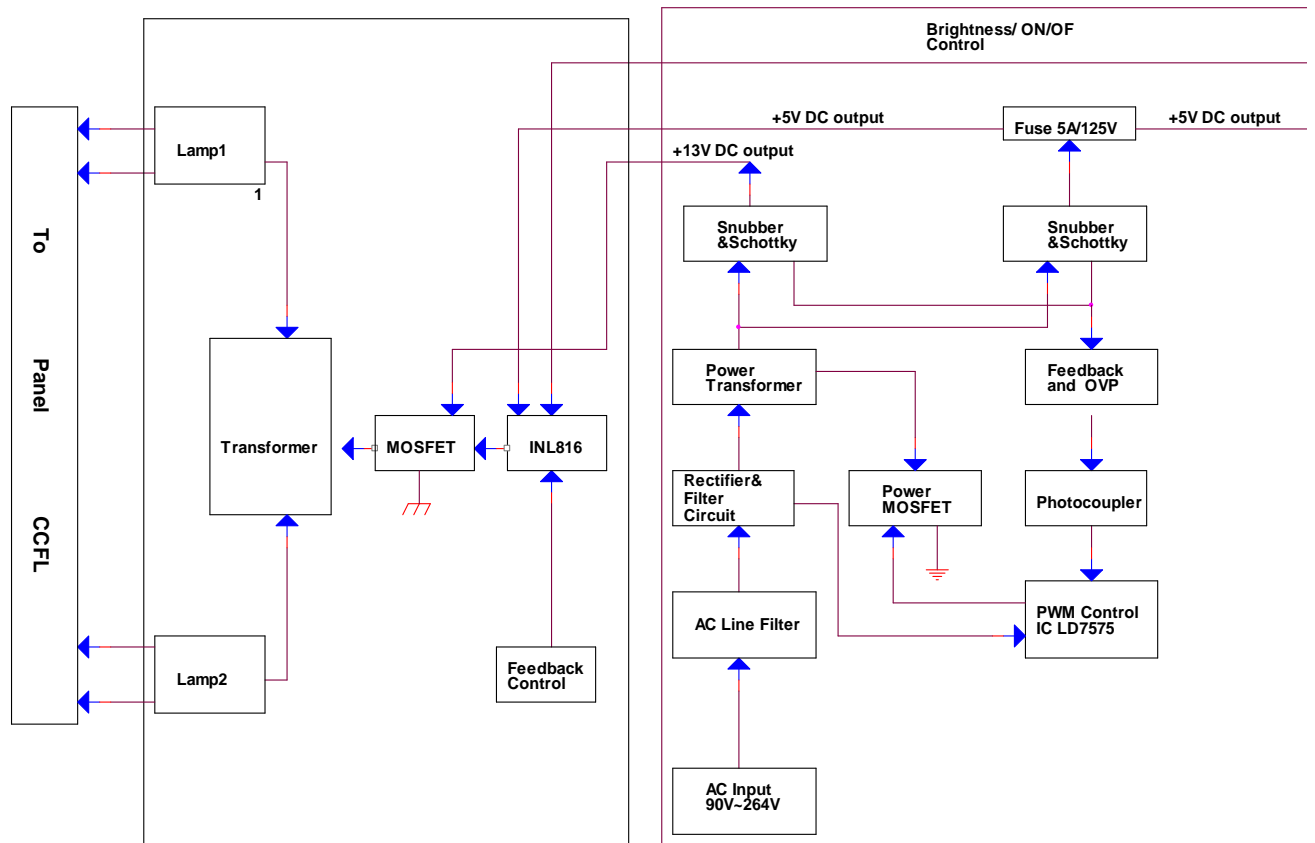
# **Chapter 2- SERVICE TOOLS & EQUIPMENT REQUIRED**

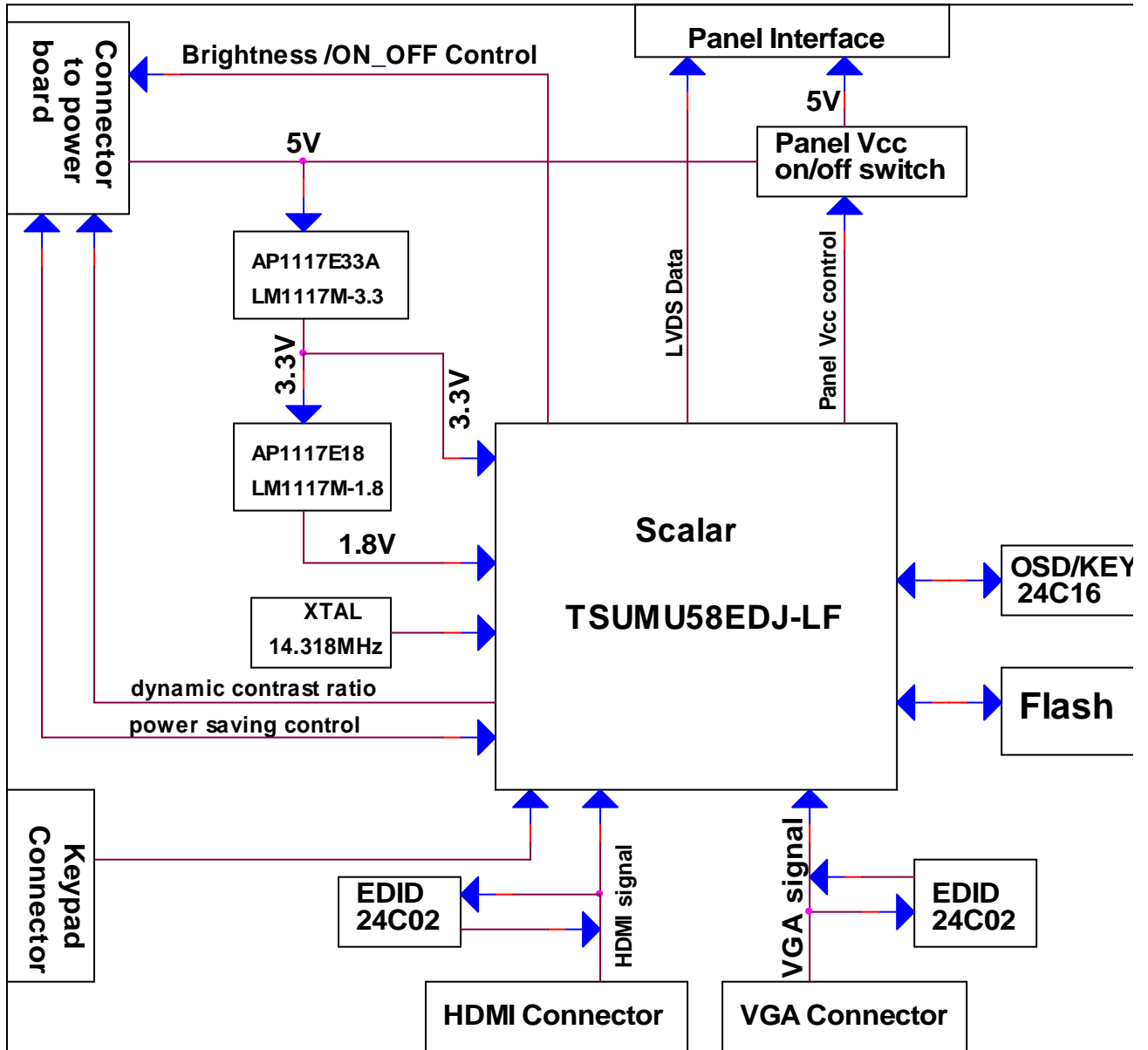
1. SIGNAL GENERATOR
2. MULTIMETER
3. SCREW DRIVER
4. OSCILLOSCOPE
5. Soldering IRON
6. SOLDER (Lead free, RoHS compliance)
7. Color Analyzer
8. Fox\_VISP\_Programmer
9. Fox\_VEDID\_Programmer

## Chapter 3- CIRCUIT THEORY

### 1. Block Diagram

Dell ST2010 consists of a main body and a stand (base). The main body contains a LCD module with 2 CCFL lamps, There are 4pcs PCBA in this monitor, one is power& inverter which is a single layer board, one is interface board, one is function keypad which is OSD control located on the right side back cover, one is power DC\_on/off key. The block diagram is shown as below (fig.1) .



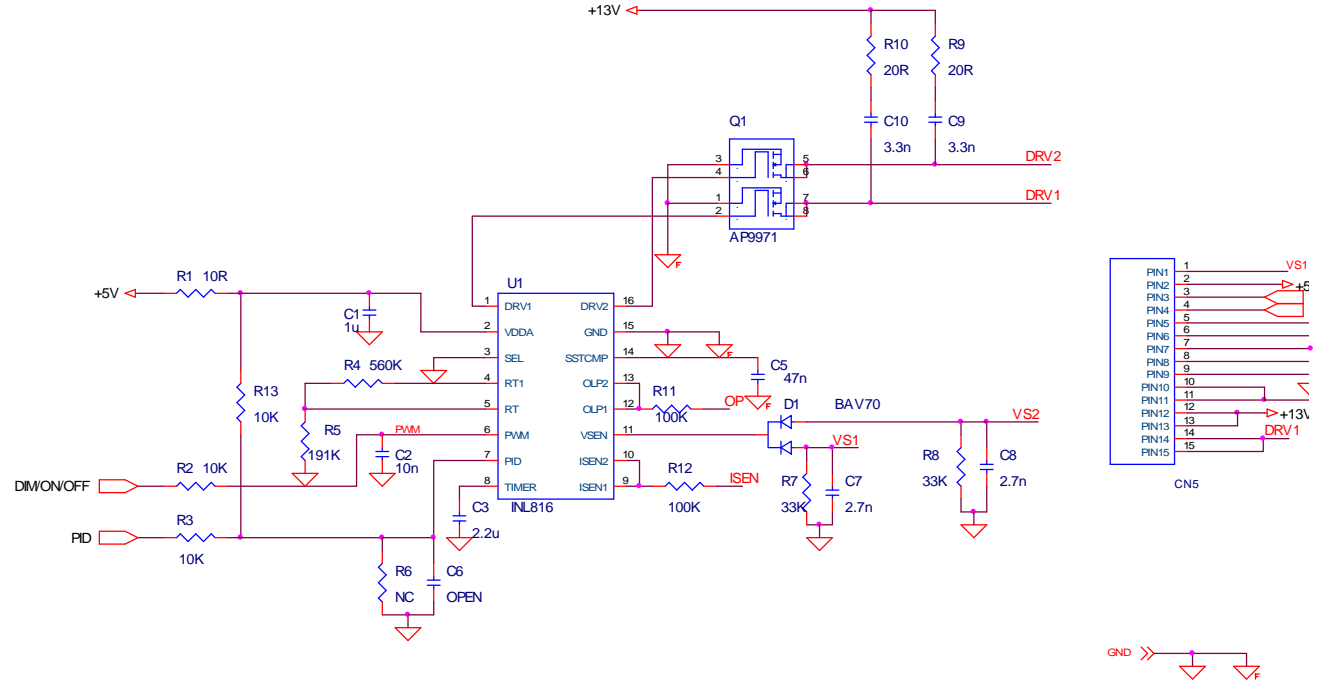


**Fig.1**

## 2. Electronic Circuit Theory

### 2.1 Inverter PWM circuit

#### 2.1.1 Inverter Control circuit operations:(fig.2)



**Confidential**  
O2Micro Inc. All rights reserved

**Fig.2**

DC\_5V through R1 and C1 will provide power for U1 on the pin2. PWM-ON/OFF and DIM voltage signal coming from scalar which is on IF BD will PWM U1 to work. During start up, ISEN (pin9 and pin10) senses the voltage on the transformer secondary. If no current is sensed approximately 2 seconds, U1 shuts off. R3 is used to limit current. C3 is used to dump noise, C5 is used to soft start, and then the voltage on pin 14 will enable U1. Once the voltage at the ISEN pin reaches the lamp on threshold, the IC switches from the striking mode to the normal operation mode and the PWM dimming control is activated.

The striking and operating frequency is determined by the external resistor (R4 and R5) and connected to Pin 4 and Pin 5.

DRV1 and DRV2 of U1 are used to drive U2. DRV1 and DRV2 are controlled by built-in PWM IC. Q1 is switched which has two built-in IGBTs. The working principle of circuit of T1, the same to circuit of Power.

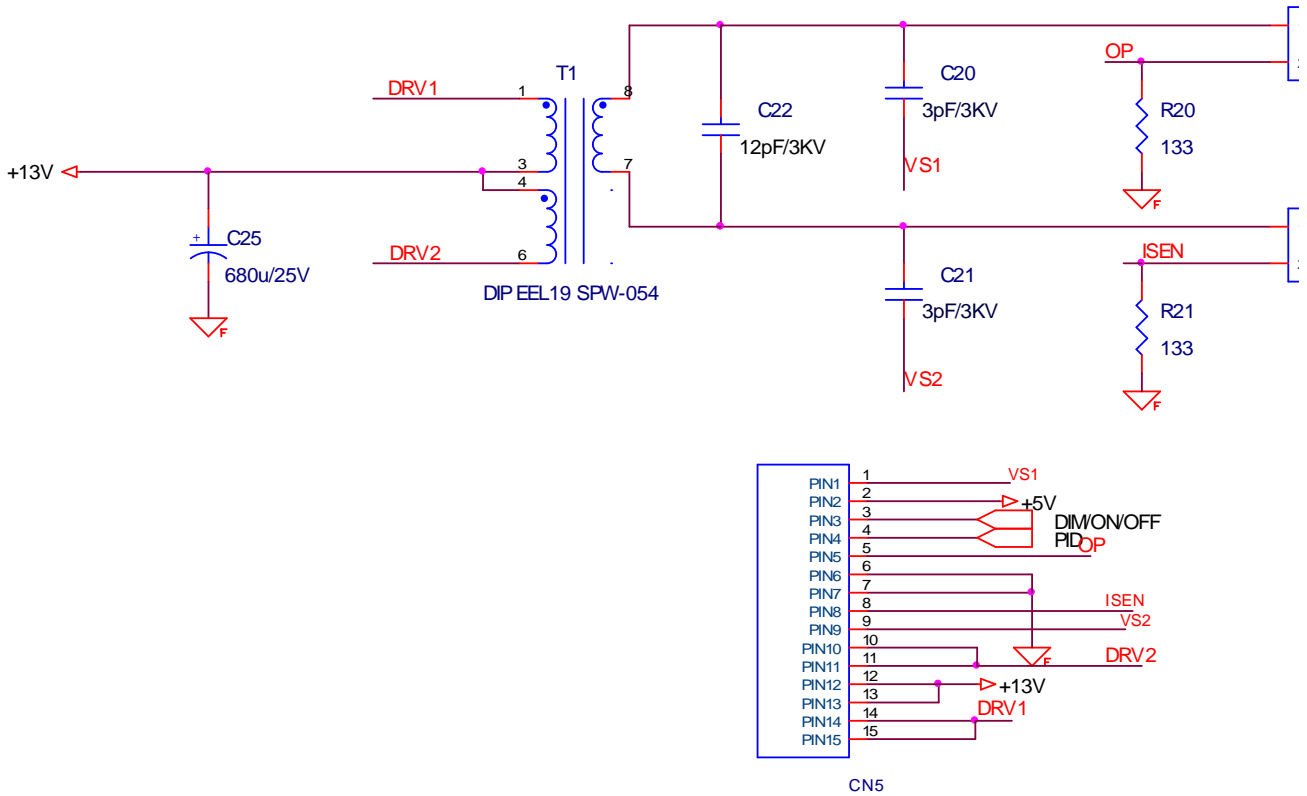
The voltage signal on negative pole of D1 sensed through R7/R8 comes to Pin11 of U1 VSEN (Lamp Current Detection & Control). The CCFL current is detected through R12/R21 and reaches a regulated value. The CCFL current detected at resistor R12/R21 is converted to a voltage level and input to the ISEN. Once the CCFLs are ignited and current is sensed through resistor R12/R21, performs the loop compensation function. The voltage at IC pin12 controls the drive duty cycle of the



## Service Manual

power MOSFETs to regulate the CCFL current.

### 2.1.2 Output Circuit and Protection Circuit operations:(fig.3)



**Fig.3**

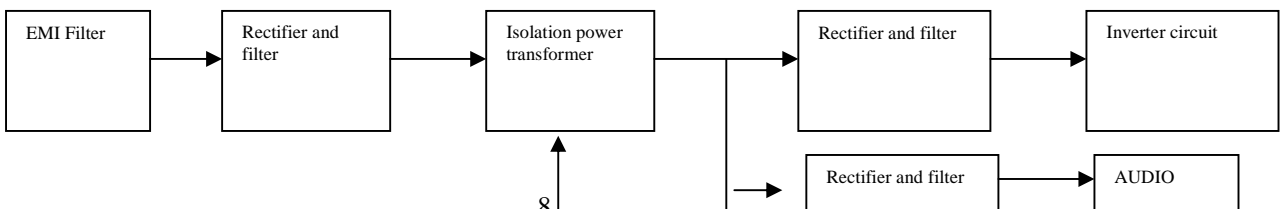
The transformer (T1) secondary winding leakage inductance and output capacitance(C31) forms a lower pass filter,which converts the square-wave driving signal into a sinusoidal output voltage signal for CCFL.

The over-voltage protection feature is implemented by using an external capacitor divider(C20/C21) to sense the output voltage.The divide-down voltage signal is sent to the IC Pin11(VSEN) ,thus regulating the output voltage.

If a CCFL is removed, fails or damaged during normal operation, CCFL current is no longer sensed and the voltage on ISEN pin drops. Once the voltage at the ISEN pin is less than the lamp” on” threshold, the shutdown timer is activated. The IC maintains the output voltage for approximately 2-3seconds and once the timer expires, the IC will shutdown. To restart the IC, either toggle the SST\_CMP pin or recycle the power on the VDDA pin.

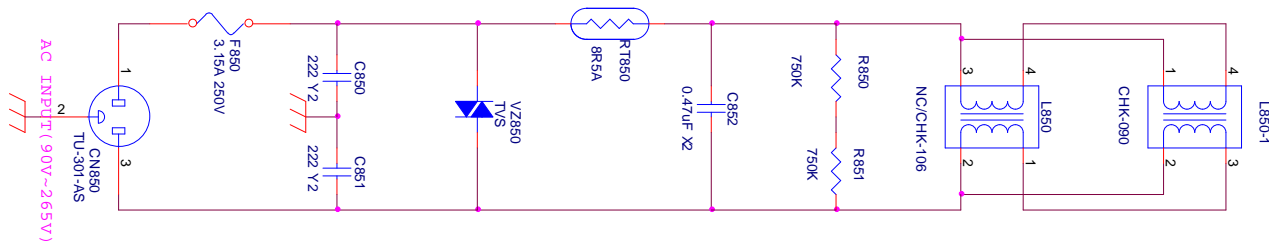
## 2.2 Power PWM circuit operations

### 2.2.1) Block diagram:(fig.4)



**Fig.4**

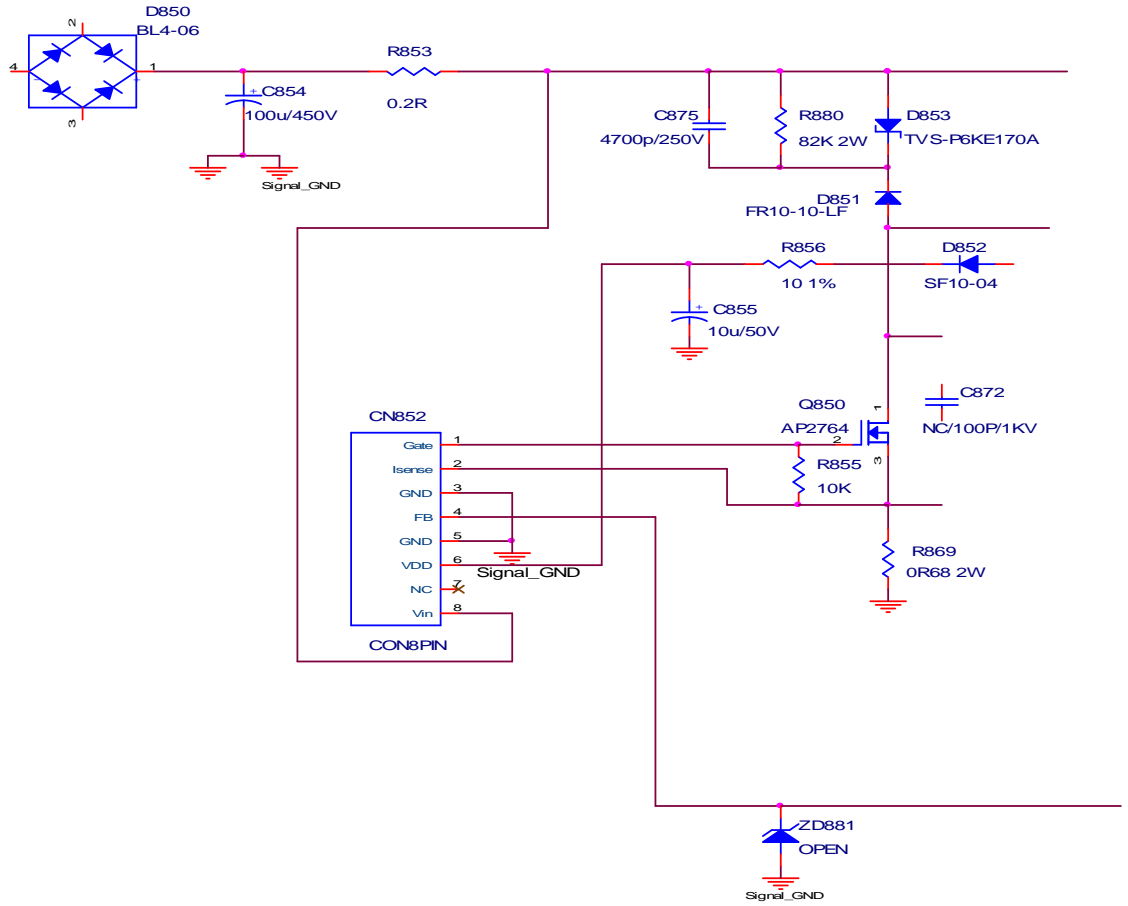
**2.2.2) AC Input and EMI Filter:(fig.5)**

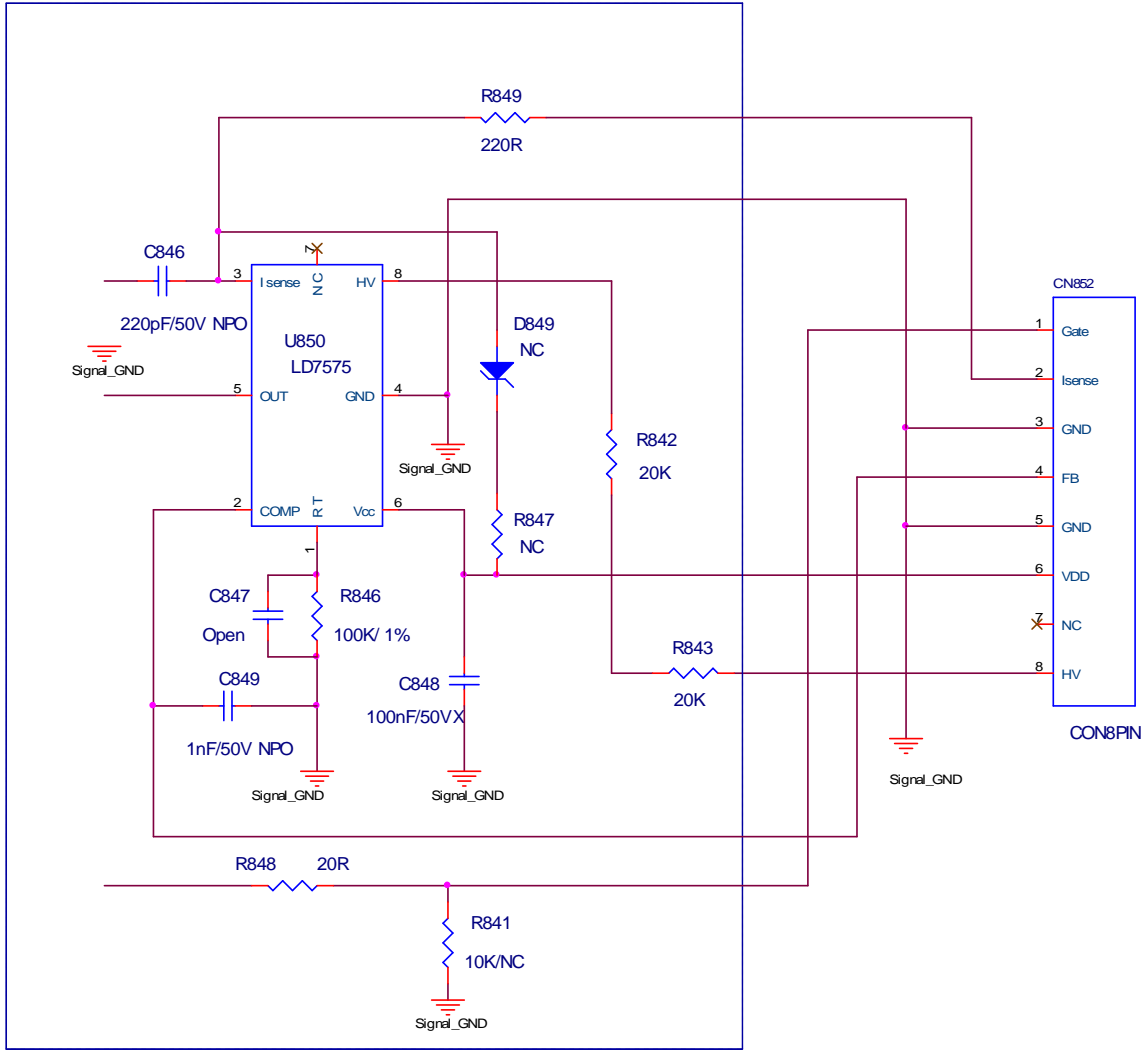


**Fig.5**

CN850 is a connector for connecting AC Power. F850 is a fuse to protect all the circuit AC. Input voltage is from 90V to 264V. R850 and R851 are joined between two inputting main circuit to prevent man from shock. L850 is used to filter low frequency noise. C850 and C851 are used to discharge the noise that L851 produced. High frequency waves are damped by C852 .

**2.2.3)High Voltage to Low Voltage Control Circuit:(fig.6)**





**Fig.6**

D850 is a rectifier in which there are 4 build-in diodes, inverting AC to DC. C854 is used to smooth the wave from rectifier. R852 is a fuse resistor to protect the following circuit when inrush current is too large.

U850 is a current-mode PWM controller with excellent power-saving operation, It features a high-voltage current source to directly supply the startup current from bulk capacitor and further to provide lossless startup circuit. Max start-up current for U850 is 100 uA, When current flow from the bulk capacitor C854 through R843 and R842 gets to HV pin to start up U850, Meanwhile, the VCC supply current is as low as 100 uA thus most of the HV current is utilized to change the VCC capacitor C855, Whenever the Vcc voltage is higher than UVLO (16V), the GATE pin will output signal to drive the power MOSFET(Q850), the high-voltage current source is off and the supply current is provided from the auxiliary winding of the transformer PIN5.

When U850 begins to operate Pin8 of U850 will output square wave to drive Q850, then the main current flow get to GND bypassing through T850, Q850. Because of the change of current flow, wires in the other side of T850 will induct current. In the same time, the current inducted by wires which connected T850 Pin 1 and Pin 3, with components of D852, R856 and C855, will be supplied to U850 for

normal operating.

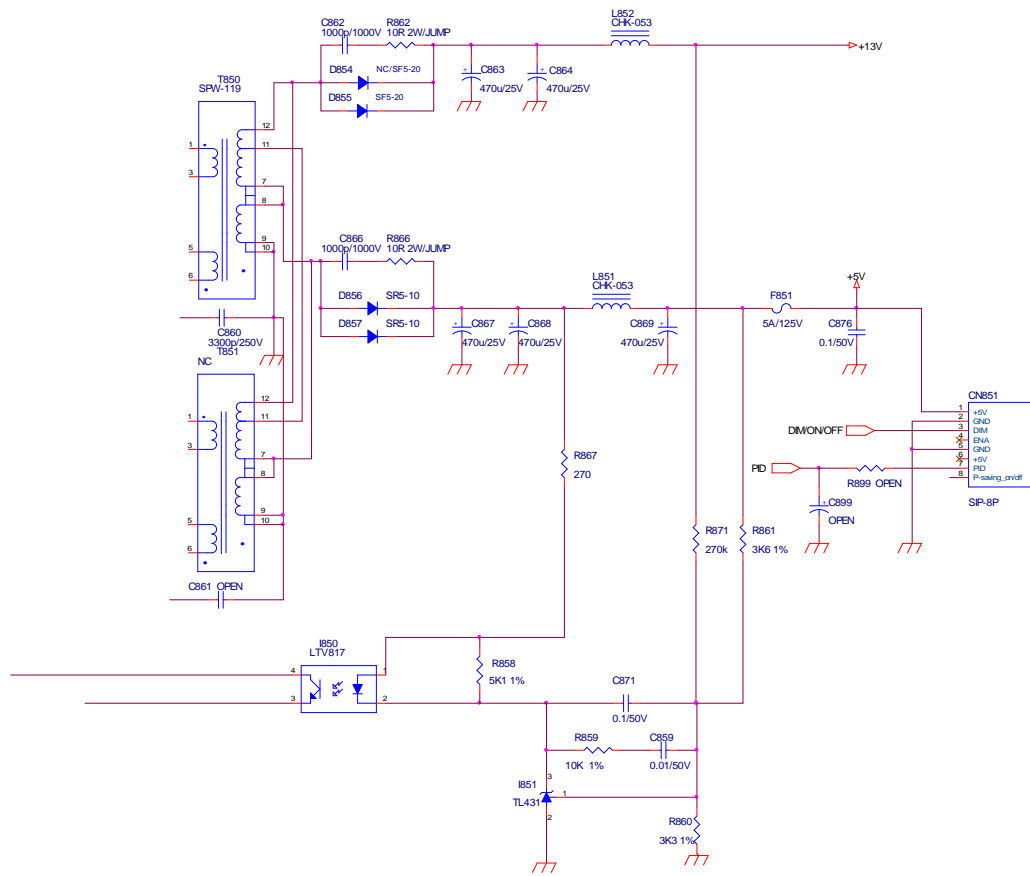
The typical current mode PWM controller feedbacks both current signal and voltage signal to close the control loop and achieve regulation. U850 detects the Q850 current from Isense pin which max voltage is set as 0.85V, then the Q850 current can be calculated as:  $I_{peak} = 0.85V / R869$ . When the sense voltage across the sense resistor R869, reaches the threshold voltage over 0.85V, the output GATE drive will be turned off. R849 and C846 is used to avoid the Isen pin damaged by the negative turn-on spike.

The voltage feedback signal is provided from the TL431 (I851) through the I850 to the COMP pin. When the voltage on COMP pin is lower than 1.2V, the IC will turn off.

When Q850 is turned off, the main current flow will be consumed through D851, C875, R880, this will prevent Q850 from being damaged under large current impulse and voltage spike.

RT pin is to program the switching frequency, by connecting R846 to ground to set the switching frequency,  $f = (65.0 / R846) * 100$  (KHz).

**2.2.4) DC 13V and DC 5V Output Circuit and Feedback circuit:(fig.7)**



**Fig.7**

D855 is used to rectify the inducted current. R862 and C862 are used to store

energy when current is reversed. The parts including C862, C863 C864 and L852 are used to smooth the current waves that are from D855, then 13V voltage is supplied.

D856 is a SCHKY diode used to rectify the inducted current. C866 and R866 are used to store energy when current is reversed, The components including C867, C868 and L851, C867 and C868 are used to smooth the current waves, then DC+5V voltage is supplied. F851 is used for OCP for the LPS test.

DC 5V supply voltage feed back to PWM controller U850 via, R861, R860, R859, C859, I851, R867 Used to control the voltage feedback loop.

## 2.3 I/F Board Circuit ([see the Attachment 2- Schematic](#))

### 2.3.1 RGB CAPTURE

- Signal RED, GREEN, BLUE input through CN102 #1, #2, #3, Stop DC via C113, C114 and C115, and then enter into U105 (TSUM58EDJ-LF) analog input PIN #28, #25, #23, and then TSUM58EDJ-LF deals with signal internally. D103, D104, D105 are ESD protector to prevent U105 from ESD.
- Signal DDC\_SCL (series clock) inputs via CN102#15, and then passes through ZD106 for ESD protection, goes into EDID EEPROM IC U103 #6.
- Signal DDC\_SDA (series data) inputs via CN102#12, and then passes through ZD103 for ESD protection, goes into EDID EEPROM IC U103 #5.
- Signal TTL vertical sync. (Vsync) inputs via CN102 #14, and then clamped by ZD105 Zener, passes through R116, and then goes into IC U105 (TSUM58EDJ-LF) #33.
- Signal TTL horizontal sync. (Hsync) inputs via CN101 #13, and then clamped by ZD104 Zener, passes through R115, and then goes into IC U105 (TSUM58EDJ-LF) #32.
- CN102#5 is defined as cable detect pin, the detect pin can create a pull-low signal send to U105#36pin via R160 to identify cable connection, if plug out the VGA cable the U105#36pin will receive a high signal and system enter self test mode when exit factory mode ( the device must set at VGA input mode ).
- U103 is an EEPROM IC which is memory and EDID data saved in it, the IC power is supplied by PC via CN102#9 with D106 and ZD102 for ESD protection, or supplied by Monitor self via D106.

### 2.3.2 HDMI CAPTURE

- TMDS differential Signal input RX0+, RX0-, RX1+, RX1-, RX2+, RX2-, RXC+, RXC- through CN201 #7, #9, #4, #6, #1, #3, #10, #12 via R206, R205, R204, R203, R202, R201, R208, R207 enter into U105 (TSUM58EDJ-LF) Digital input terminal #15, #16, #12, #13, #9, #10, #18, #19, and then TSUM58EDJ-LF deals with signal internally.
- Signal DDC\_SCL (series clock) inputs via CN201#15, via R209, goes into EDID EEPROM IC U201 #6.
- Signal DDC\_SDA (series data) inputs via CN201#16, via R210, goes into EDID EEPROM IC U201 #5.
- CN201#17 is defined as cable detect pin, the detect pin can create a pull-low signal send to U105#3pin via R158 to identify cable connection, if plug out the

## Service Manual

- HDMI cable the U105#3pin will receive a high signal and system enter self test mode when exit factory mode ( the device must set at HDMI input mode ) .
- U204 is an EEPROM IC which is memory and HDMI input EDID data saved in it ,the U204 power is supplied by PC via CN201#18 through D201, or supplied by Monitor self via D201.

### 2.3.3 Buttons Control

- Button “Power” on right corner of front bezel connects to U105 (TSUM58EDJ-LF ) #119 through CN104 #1 and R153, U105 #119 is defined as power on/off.
- Button “+” and “-” on right corner of front bezel connects to U105 (TSUM58EDJ-LF) #120 through CN104 #2and R154, U105#120 is defined as “Plus and minus” using with AD converting control technology.
- Button “Menu” and “Exit”on right corner of front bezel connects to U105 (TSUM58EDJ-LF) #121 through CN104 #4and R155, U105 #121 is defined as “Menu”and “Exit” using with AD converting control technology.
- LED Indicator on Front Bezel
  - a. When press button “power”, U105 (TSUM58EDJ-LF) #123 be send in low Voltage, make Q107#3 sends out high Voltage to CN104#3 , and then to keypad, LED blue on.
  - b. When in “Suspend” mode, U105 (TSUM58EDJ-LF) #124 sends out a low Voltage, make Q108#3 sends out high Voltage to CN104#5 , and then to keypad, LED Amber on.

### 2.3.4 MAIN CHIP U105 (TSUM58EDJ-LF)

- U105 (TSUM58EDJ-LF ) #86~#77 output 8 bit even and #100~#91 output 8 bit odd LVDS digital data to panel control circuit through CN103.
- U105 (TSUM58EDJ-LF ) #73 output PPWR ”H” potential to make Q104 conducted, and then make Q101 conducted, +5V flow to CN103#1~#3 as Panel Vdd .
- U105 (TSUM58EDJ-LF) #125 outputs Brightness “PWM” signals to control CCFL brightness and on/off.
- TCLK by Crystal 14.318MHz input to U105 (TSUM58EDJ-LF) #128.
- U105(TSUM58EDJ-LF) #108 is RESET signals input pin  
Please refer to TSUM58EDJ-LF Pin Assignments table in page

### 2.3.5 Regulator Circuit

- +5V is from switching power supply .
- +3.3V is generated from Regulator U101 which is supplied by+5V through C101 filtering, C102 and C105 is 3.3V which supplies toU102、 U106、 U103、 U201、 U105、 U108output filtering.
- +1.8V is generated from Regulator U102 which is supplied byU101-3.3V through C106 filtering.TheU102 output1.8V via FB105 send to U105.

## **3. FACTORY PRESET TIMING TABLE**

### 3.1 VGA

## Service Manual

Resolution	Pixel clock	H-sync	V-sync
	(unit:MHz)	(unit:KHz)	(unit:Hz)
<b>640x480</b>	<b>25.17</b>	<b>31.47</b>	<b>59.94</b>
<b>640x480</b>	<b>31.50</b>	<b>37.50</b>	<b>75.00</b>
<b>720x400</b>	<b>28.32</b>	<b>31.47</b>	<b>70.08</b>
<b>800x600</b>	<b>40.00</b>	<b>37.88</b>	<b>60.32</b>
<b>800x600</b>	<b>49.50</b>	<b>46.88</b>	<b>75.00</b>
<b>1024x768</b>	<b>65.00</b>	<b>48.36</b>	<b>60.00</b>
<b>1024x768</b>	<b>78.75</b>	<b>60.02</b>	<b>75.03</b>
<b>1152x864</b>	<b>108.00</b>	<b>67.50</b>	<b>75.00</b>
<b>1280x800</b>	<b>83.50</b>	<b>49.702</b>	<b>59.81</b>
<b>1280x1024</b>	<b>108.00</b>	<b>63.98</b>	<b>60.02</b>
<b>1280x1024</b>	<b>135.00</b>	<b>79.976</b>	<b>75.025</b>
<b>1600x900R</b>	<b>97.750</b>	<b>55.54</b>	<b>59.978</b>

### 3.2 HDMI

Resolution	Pixel clock	H-sync	V-sync
	(unit:MHz)	(unit:KHz)	(unit:Hz)
<b>640x480</b>	<b>25.17</b>	<b>31.47</b>	<b>59.94</b>
<b>640x480</b>	<b>31.50</b>	<b>37.50</b>	<b>75.00</b>
<b>720x400</b>	<b>28.32</b>	<b>31.47</b>	<b>70.08</b>
<b>800x600</b>	<b>40.00</b>	<b>37.88</b>	<b>60.32</b>
<b>800x600</b>	<b>49.50</b>	<b>46.88</b>	<b>75.00</b>
<b>1024x768</b>	<b>65.00</b>	<b>48.36</b>	<b>60.00</b>
<b>1024x768</b>	<b>78.75</b>	<b>60.02</b>	<b>75.03</b>
<b>1152x864</b>	<b>108.00</b>	<b>67.50</b>	<b>75.00</b>
<b>1280x800</b>	<b>83.50</b>	<b>49.702</b>	<b>59.81</b>
<b>1280x1024</b>	<b>108.00</b>	<b>63.98</b>	<b>60.02</b>
<b>1280x1024</b>	<b>135.00</b>	<b>79.976</b>	<b>75.025</b>
<b>1600x900R</b>	<b>97.750</b>	<b>55.54</b>	<b>59.978</b>

## 4. Power On/Off Sequency

Hardware power On/Off

When power-cord plug into AC socket, power board will provide DC\_5V to interface board.

DC\_5V is main voltage for panel and Regulator U101.

DC\_3.3V is coming from Regulator U101, DC\_3.3v is main voltage for U105.

When DC\_3.3V input to U105 and U105 reset circuit active, U105 all registers will be set to default, that means finish hardware power on.

When pull out power cord from AC socket,the system shut down instantly for no supply



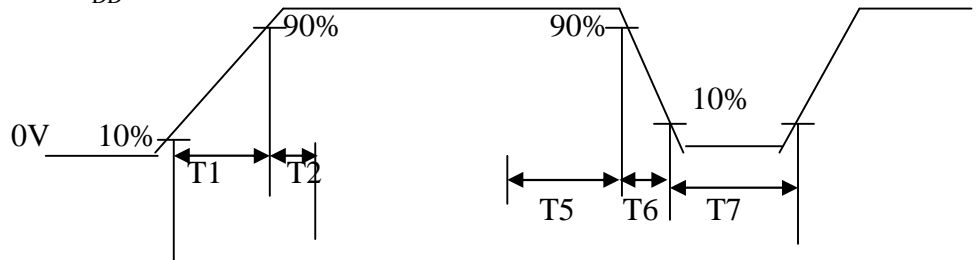
## Service Manual

### Software power On/Off

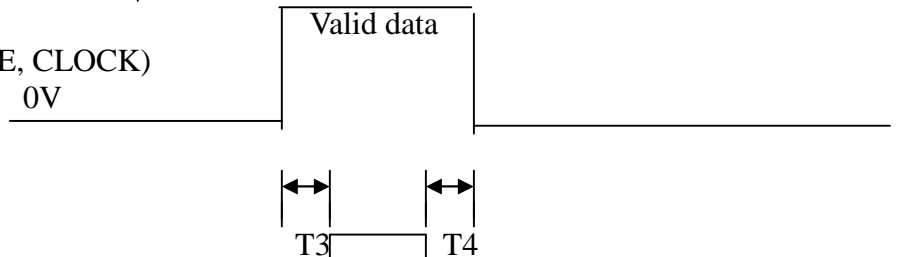
- When press power key, U105 #119 receives low pulse, then U105(TSUM58EDJ-LF) will be wake up and send control signals(at U105#125pin and #73Pin) to on CCFL and switch 5.0v to panel module, at the same time,U105 make the VGA/HDMI cable input signal source display normal on panel if the VGA/HDMI cable input signal is active
- If power ON, U105 #123 (LED\_blue) will send out low potential, and then LED blue on.
- If power saveing, U105 #124 (LED\_Amber) will send out low potential, and then LED Amber on.
- If power ON or power saveing, when press power key, U105 #119 pin receives low pulse, then U105 will be sleeping and turn off backlight, at the same time, the panel will lose +5V.

The Panel\_Vcc, Backlight\_En, CLK/DATA output to panel will follow the following sequency.

Power supply for panel+5V  $V_{DD}$



Signals  
(Digital RGB, HS, VS, DE, CLOCK)



Power supply for backlight

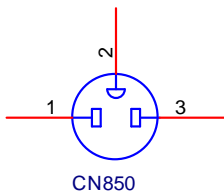


	T1(ms)	T2 (ms)	T3 (ms)	T4 (ms)	T5 (ms)	T6 (ms)	T7(ms)
SPEC(Samsun g)	0.3~10	0.0~50	>500	>100	0.0~50	NA	>1000

## 5. D-SUB Connector Pin Assignment

Pin	Symbol	Pin	Symbol
1	Red	6	Red_GND
2	Green	7	Green_GND
3	Blue	8	Blue_GND
4	GND	9	PC+5V
5	Cable Detect	10	GND
		11	GND
		12	DDC_SDA
		13	Hsync
		14	Vsync
		15	DDC_SCL

## 6. AC Outlet Pin Assignment



Pin	Symbol	Description
1	Line	
2	GND	
3	Neutral	

## 7. Inner Connector Pin Assignment

7.1 CN103 (Connect interface board to Panel,)

## Service Manual

Pin	Symbol	Description
1	Panel_Vcc	Panel power supply (typ.5.0V)
2	Panel_Vcc	Panel power supply (typ. 5.0V)
3	Panel_Vcc	Panel power supply (typ. 5.0V)
4	NC	
5	NC	
6	NC	
7	GND_LVDS	LVDS Ground
8	RXE3+	LVDS signal of even channel 3(-)
9	RXE3-	LVDS signal of even channel 3(+)
10	RXEC+	LVDS signal of even channel clock (+)
11	RXEC-	LVDS signal of even channel clock (-)
12	RXE2+	LVDS signal of even channel 2(+)
13	RXE2-	LVDS signal of even channel 2(-)
14	GND_LVDS	LVDS Ground
15	RXE1+	LVDS signal of even channel 1(+)
16	RXE1-	LVDS signal of even channel 1(-)
17	GND_LVDS	LVDS Ground
18	RXE0+	LVDS signal of odd channel 0(+)
19	RXE0-	LVDS signal of odd channel 0(-)
20	RXO3+	LVDS signal of odd channel 3(+)
21	RXO3-	LVDS signal of odd channel 3(-)
22	RXOC+	LVDS signal of even channel clock (+)
23	RXOC-	LVDS signal of even channel clock (-)
24	GND_LVDS	LVDS Ground
25	RXO2+	LVDS signal of even channel 2(+)
26	RXO2-	LVDS signal of even channel 2(-)
27	RXO1+	LVDS signal of even channel 1(+)
28	RXO1-	LVDS signal of even channel 1(-)
29	RXO0+	LVDS signal of odd channel 0(+)
30	RXO0-	LVDS signal of odd channel 0(-)

### 7.2 CN1, CN2 (Connect to Panel Backlight,)

Pin	Symbol	Description
1	HV	High voltage for lamp
2	LV	Low voltage for lamp

### 7.3 CN104 (Connect to keypad, WAFER2\*4P or compatible connector)

Pin	Symbol	Description
1	POWER	OSD "POWER" control
2	MINUS/PLUS	OSD "PLUS" or "MINUS" control
3	LED_white	LED white on/off control
4	MENU/ENTER	OSD "MENU/ENTER" control
5	LED_Amber	LED Amber on/off control
6	GND	Ground
7	GND	Ground
8	GND	Ground



**Service Manual**

---

## 8. Key Parts Pin Assignments

### 8.1 U105(TSUMU58EDJ-LF)

#### PIN DESCRIPTION

##### Analog Interface

Pin Name	Pin Type	Function	Pin
HSYNC0	Schmitt Trigger Input w/ 5V-tolerant	Analog HSYNC Input	32
VSYNC0	Schmitt Trigger Input w/ 5V-tolerant	Analog VSYNC Input	33
REFP		Internal ADC Top De-Coupling Pin	31
REFM		Internal ADC Bottom De-Coupling Pin	30
RINOP	Analog Input	Analog Red Input	28
RINOM	Analog Input	Reference Ground for Analog Red Input	27
SOGINO	Analog Input	Sync-On-Green Input	26
GINOP	Analog Input	Analog Green Input	25
GINOM	Analog Input	Reference Ground for Analog Green Input	24
BINOP	Analog Input	Analog Blue Input	23
BINOM	Analog Input	Reference Ground for Analog Blue Input	22
REXT		External Resistor 390 ohm to AVDD_33	7

##### DVI/HDMI Interface

Pin Name	Pin Type	Function	Pin
RX0N	DVI/HDMI Input	Negative DVI/HDMI Input for Data Channel 0	16
RX0P	DVI/HDMI Input	Positive DVI/HDMI Input for Data Channel 0	15
RX1N	DVI/HDMI Input	Negative DVI/HDMI Input for Data Channel 1	13
RX1P	DVI/HDMI Input	Positive DVI/HDMI Input for Data Channel 1	12
RX2N	DVI/HDMI Input	Negative DVI/HDMI Input for Data Channel 2	10
RX2P	DVI/HDMI Input	Positive DVI/HDMI Input for Data Channel 2	9
RXCKN	DVI/HDMI Input	Negative DVI/HDMI Input for Clock Channel	19
RXCKP	DVI/HDMI Input	Positive DVI/HDMI Input for Clock Channel	18

##### Serial Flash Interface

Pin Name	Pin Type	Function	Pin
SDO	Input w/ 5V-tolerant	SPI Flash Serial Data Output	41
CSZ	Output	SPI Flash Chip Select	42
SCK	Output	SPI Flash Serial Clock	43
SDI	Output	SPI Flash Serial Data Input	44



## Service Manual

### LVDS Interface

Pin Name	Pin Type	Function	Pin
LVA0M	Output	LVDS A-Link Channel 0 Negative Data Output	86
LVA0P	Output	LVDS A-Link Channel 0 Positive Data Output	85
LVA1M	Output	LVDS A-Link Channel 1 Negative Data Output	84
LVA1P	Output	LVDS A-Link Channel 1 Positive Data Output	83
LVA2M	Output	LVDS A-Link Channel 2 Negative Data Output	82
LVA2P	Output	LVDS A-Link Channel 2 Positive Data Output	81
LVA3M	Output	LVDS A-Link Channel 3 Negative Data Output	78
LVA3P	Output	LVDS A-Link Channel 3 Positive Data Output	77
LVACKM	Output	LVDS A-Link Negative Clock Output	80
LVACKP	Output	LVDS A-Link Positive Clock Output	79
LVB0M	Output	LVDS B-Link Channel 0 Negative Data Output	100
LVB0P	Output	LVDS B-Link Channel 0 Positive Data Output	99
LVB1M	Output	LVDS B-Link Channel 1 Negative Data Output	98
LVB1P	Output	LVDS B-Link Channel 1 Positive Data Output	97
LVB2M	Output	LVDS B-Link Channel 2 Negative Data Output	96
LVB2P	Output	LVDS B-Link Channel 2 Positive Data Output	95
LVB3M	Output	LVDS B-Link Channel 3 Negative Data Output	92
LVB3P	Output	LVDS B-Link Channel 3 Positive Data Output	91
LVBCKM	Output	LVDS B-Link Negative Clock Output	94
LVBCKP	Output	LVDS B-Link Positive Clock Output	93

### Audio Output Interface

Pin Name	Pin Type	Function	Pin
MCKO	Output	Audio Master Clock Output; 8mA driving strength	45
AUOUTLR	Output	Audio Sample Clock Output; 4mA driving strength	46
AUSCK	Output	Audio Serial Clock Output; 8mA driving strength	47
AUSD	Output	Audio Serial Data Output; 4mA driving strength	48
AUMUTE / GPIO_P43	I/O w/ 5V-tolerant	Audio Output Mute Control / General Purpose Input/Output; 4mA driving strength	49
SPDIFO / CEC_BUS / GPIO_P42	Input/Output	Audio SPDIF Output / HDMI Consumer Electronics Control (CEC) Bus Input/Output / General Purpose Input/Output; 4mA driving strength	50

Note: Pin #49/50 and #75/76 cannot be used as GPIO/GPO concurrently. When using pin #49/50 as GPIO\_P43/GPIO\_P42, pin #75/76 should be NC, and vice versa.



## Service Manual

### GPIO Interface

Pin Name	Pin Type	Function	Pin
GPIO_P14 / PWM0	I/O w/ 5V-tolerant	General Purpose Input/Output / Pulse Width Modulation Output; 4mA driving strength	2
GPIO_P15	I/O w/ 5V-tolerant	General Purpose Input/Output; 4mA driving strength	3
GPIO_P16	I/O w/ 5V-tolerant	General Purpose Input/Output; 4mA driving strength	4
GPIO_P22 / PWM1	I/O w/ 5V-tolerant	General Purpose Input/Output / Pulse Width Modulation Output; 4mA driving strength	36
GPIO_P24 / PWM2	I/O w/ 5V-tolerant	General Purpose Input/Output / Pulse Width Modulation Output; 4mA driving strength	51
GPIO_00	I/O w/ 5V-tolerant	General Purpose Input/Output; 4mA driving strength	55
GPIO_01	I/O w/ 5V-tolerant	General Purpose Input/Output; 4mA driving strength	56
GPIO_02	I/O w/ 5V-tolerant	General Purpose Input/Output; 4mA driving strength	57
GPIO_06	I/O w/ 5V-tolerant	General Purpose Input/Output; 4mA driving strength	70
GPIO_P04 / PWM3	I/O w/ 5V-tolerant	General Purpose Input/Output / Pulse Width Modulation Output; 4mA driving strength	73
GPO_P42	Output	General Purpose Output; 4mA driving strength	75
GPO_P43	Output	General Purpose Output; 4mA driving strength	76
GPIO_P25 / PWM3	I/O w/ 5V-tolerant	General Purpose Input/Output / Pulse Width Modulation Output; 4mA driving strength	109
GPIO_P26 / PWM0	I/O w/ 5V-tolerant	General Purpose Input/Output / Pulse Width Modulation Output; 4mA driving strength	110
GPIO_P27 / PWM1	I/O w/ 5V-tolerant	General Purpose Input/Output / Pulse Width Modulation Output; 4mA driving strength	111



GPIO_07	I/O w/ 5V-tolerant	General Purpose Input/Output; 4mA driving strength	115
GPIO_08	I/O w/ 5V-tolerant	General Purpose Input/Output; 4mA driving strength	116
GPIO_09	I/O w/ 5V-tolerant	General Purpose Input/Output; 4mA driving strength	117
GPIO_10	I/O w/ 5V-tolerant	General Purpose Input/Output; 4mA driving strength	118
GPIO_P00 / SAR0	I/O w/ 5V-tolerant	General Purpose Input/Output; 4mA driving strength / SAR ADC Input	119
GPIO_P01 / SAR1	I/O w/ 5V-tolerant	General Purpose Input/Output; 4mA driving strength / SAR ADC Input	120
GPIO_P02 / SAR2	I/O w/ 5V-tolerant	General Purpose Input/Output; 4mA driving strength / SAR ADC Input	121
GPIO_P03 / SAR3	I/O w/ 5V-tolerant	General Purpose Input/Output; 4mA driving strength / SAR ADC Input	122
GPIO_P06	I/O w/ 5V-tolerant	General Purpose Input/Output; 6/12mA programmable driving strength	123



## Service Manual

GPIO_P07	I/O w/ 5V-tolerant	General Purpose Input/Output; 6/12mA programmable driving strength	124
GPIO_P13 / PWM2	I/O w/ 5V-tolerant	General Purpose Input/Output / Pulse Width Modulation Output; 4mA driving strength	125

Note: Pin #49/50 and #75/76 cannot be used as GPIO/GPO concurrently. When using pin #49/50 as GPIO\_P43/ GPIO\_P42, pin #75/76 should be NC, and vice versa.

### Misc. Interface

Pin Name	Pin Type	Function	Pin
BYPASS		For External Bypass Capacitor	102
VCTRL	Output	Regulator Control	103
RST	Input w/ 5V-tolerant	Chip Reset; High Reset	108
MODE	Input	Chip Configuration Input; 10K ohm pull-low for normal operation	37
DDCD_SDA	I/O w/ 5V-tolerant	DDC Data and HDCP Slave Serial Port Data for DVI/HDMI Interface; 4mA driving strength	5
DDCD_SCL	Input w/ 5V-tolerant	DDC Clock and HDCP Slave Serial Port Clock for DVI/HDMI Interface	6
DDCA_SDA / RS232_TX	I/O w/ 5V-tolerant	DDC Data for Analog Interface / UART Transmitter / General Purpose Input/Output; 4mA driving strength	34
DDCA_SCL / RS232_RX	I/O w/ 5V-tolerant	DDC Clock for Analog Interface / UART Receiver / General Purpose Input/Output; 4mA driving strength	35
I2C_MDA / GPIO_P11	I/O w/ 5V-tolerant	I2C Master Data / General Purpose Input/Output; 4mA driving strength	38
I2C_MCL / GPIO_P10	I/O w/ 5V-tolerant	I2C Master Clock / General Purpose Input/Output; 4mA driving strength	39
XIN	Crystal Oscillator Input	Xin	128
XOUT	Crystal Oscillator Output	Xout	127



**Power Pins**

Pin Name	Pin Type	Function	Pin
AVDD_33	3.3V Power	Analog Power	8, 14, 20
AVDD_18	1.8V Power	Analog Power	21
VDDP	3.3V Power	Digital Output Power	40, 58, 59, 71, 87, 107, 114
VDDC	1.8V Power	Digital Core Power	53, 74, 104, 126
GND	Ground	Ground	1, 11, 17, 29, 52, 62, 63, 68, 69, 72, 88, 101, 105, 106, 113

**No Connects**

Pin Name	Pin Type	Function	Pin
NC		No Connect. Leave These Pins Floating.	54, 60, 61, 64-67, 89, 90, 112

**8.2 U108 (Serial Flash)**

Pin	Symbol	I/O	Description
1	CE#	I	The device is enabled by a high to low transition on CE#. CE# must remain low for the duration of any command sequence.
2	SO	I/O	To transfer commands, addresses, or data serially into the device.
3	WP#	I/O	The write protect (WP#) pin is used to enable/disable BPL bit in the status register.
4	VSS	G	Connect ground
5	SI	I/O	To transfer commands, addresses, or data serially into the device input are latched on the rising edge of the serial clock.
6	SCK	I/O	To provide the timing of serial interface. Commands, addresses, or input data are latched on the rising edge of the clock input, while output data is shifted out on the Falling edge of the clock input.
7	HOLD	I/O	To temporarily stop serial communication with SPI flash memory without resetting the device.
8	VDD	P	To provide power supply.

### 8.3 U850 (LD7575, Power Controller)

Pin	Symbol	I/O	Description
1	RT		This pin is to program the switching frequency
2	COMP	I	Voltage feedback pin,By connecting a photo-coupler to close the control loop and achieve the regulation
3	CS	I	Current sence pin
4	GND		
5	OUT	O	PWM output ,Gate drive output to drive the external MOSFET
6	VCC	I	Power supply
7	NC		Unconnected pin
8	HV	I	PWM output

### 8.4 U1 ( INL816GN, CCFL Inverter controller IC)

Pin	Symbol	I/O	Description
1	DRV1	O	Driver output 1
2	VDDA	I	Supply voltage input
3	SEL	I	Select Signal for Push-Pull or Half-Bridge Topology
4	RT1	I/O	Timing Resistor for Striking Frequency
5	RT	I/O	Timing Resistor for Operation Frequency
6	ENAPWM	I	Enable and PWM Dimming input
7	PID	I	Analog Dimming input
8	TIMER	I/O	Timing Capacitor for Delay Timer
9	ISEN1	I	Currentfeedback1
10	ISEN2	I	Currentfeedback2
11	VSEN	I	Voltage Feedback
12	OLP1	I	Open-Lamp Protection Sense1
13	OLP2	I	Open-Lamp Protection Sense2
14	SSTCMP	I/O	Soft-Start and Compensation
15	GNDA		Ground
16	DRV2	O	Driver output 2

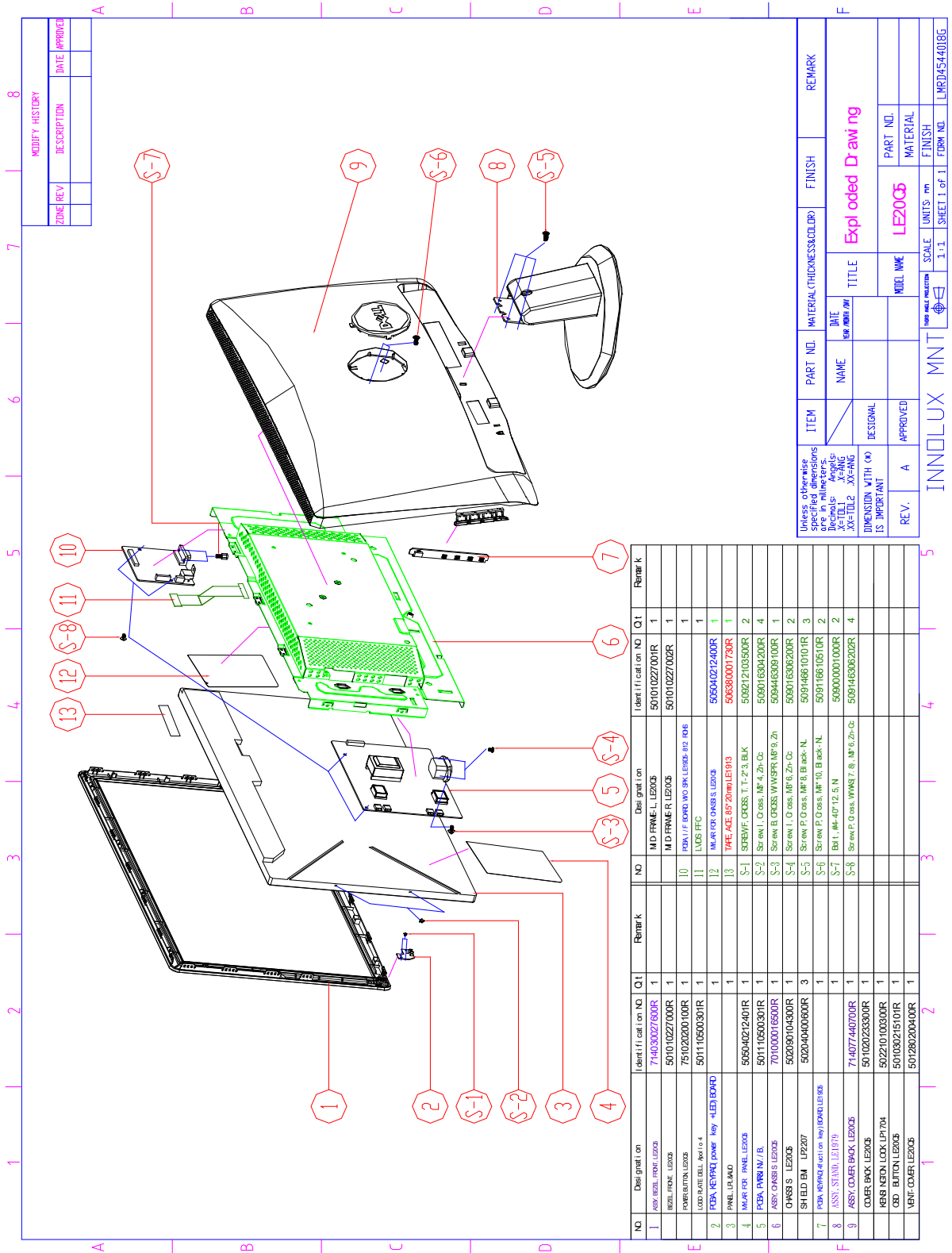


---

**Service Manual**

**Chapter 4- Disassembly & Assembly**

**1. Exploded Diagram**



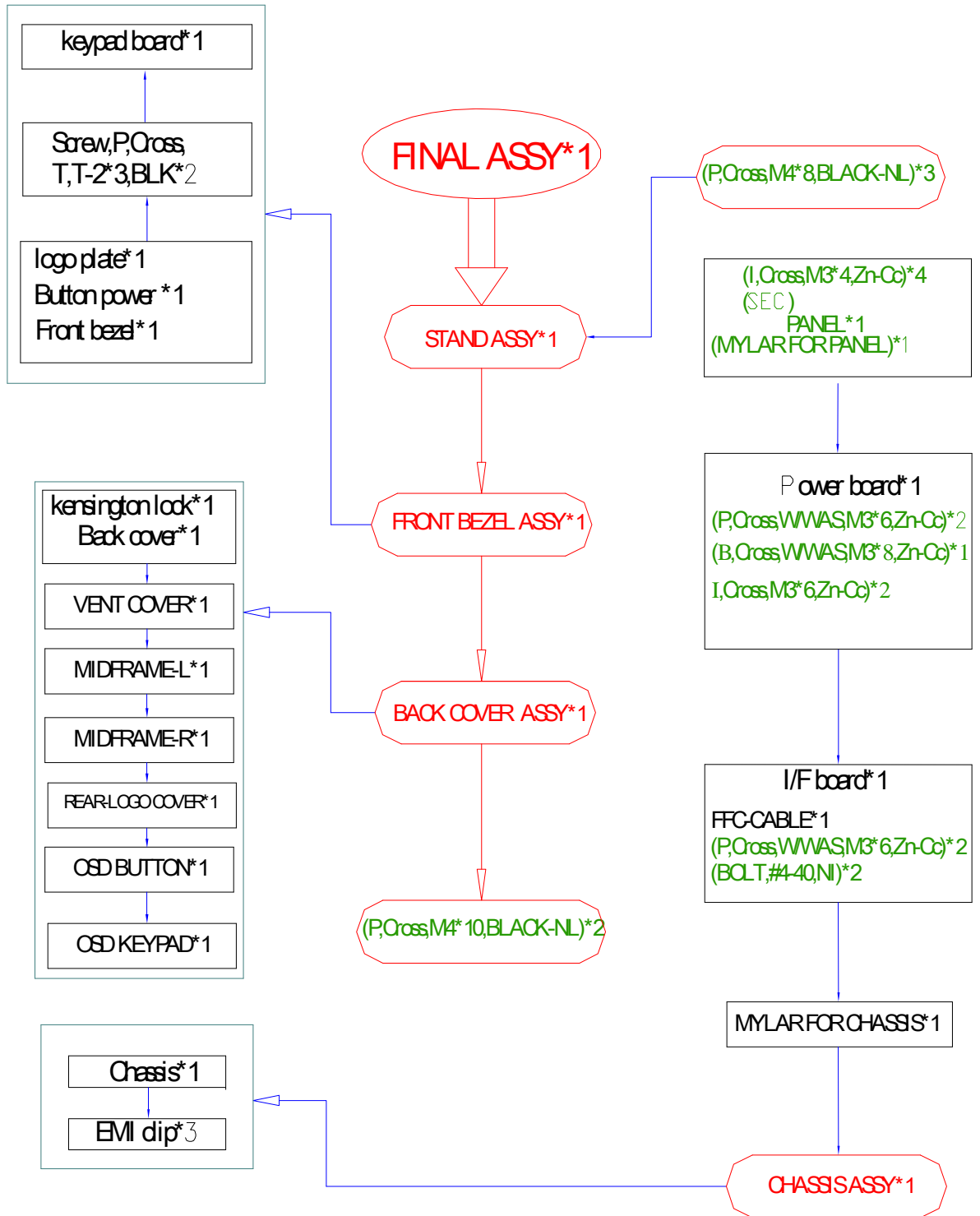
MODIFY HISTORY	
ZONE REV	DATE APPROVED

ITEM	PART NO.	MATERIAL THICKNESS/COLOR	FINISH	REMARK
NAME				
DATE EXP. AUTH. / IN.				
DESIGNAL				
APPROVED				
REV. A				
DIMENSION WITH 00		TITLE		PART NO.
IS IMPORTANT		Exploded Drawing		LE2005
		MODEL NAME		MATERIAL
				FINISH
		SCALE		UNITS: mm
		1:1		SHEET 1 of 1
				FORM NO. LMRD4544018G

INNOVUX MNT

**2. ST2010 Disassembly Block**

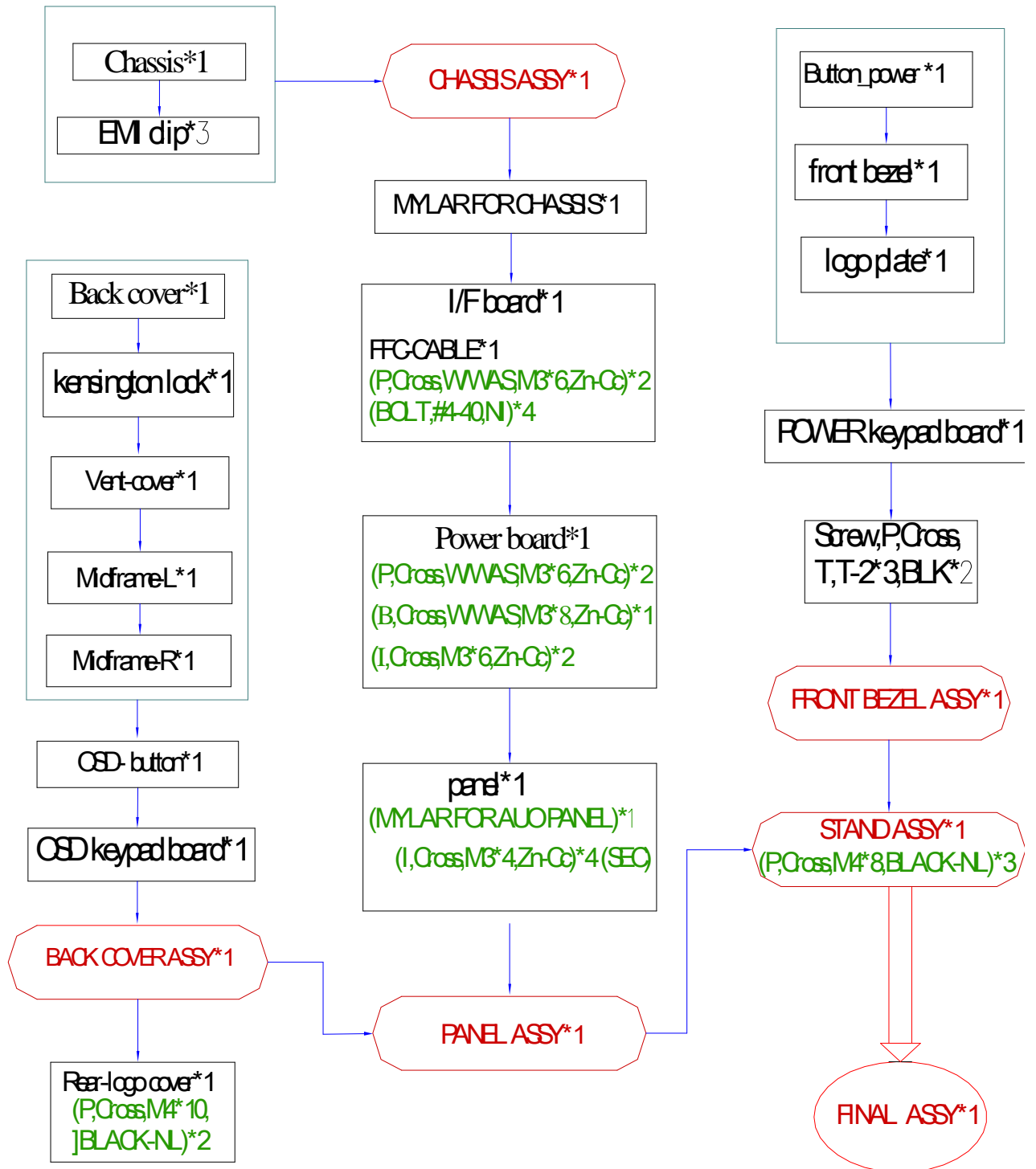
# LE20Q5 DISASSEMBLY BLOCK





### **3. ST2010 Assembly Block**

# LE20Q5 ASSEMBLY BLOCK





**Service Manual**

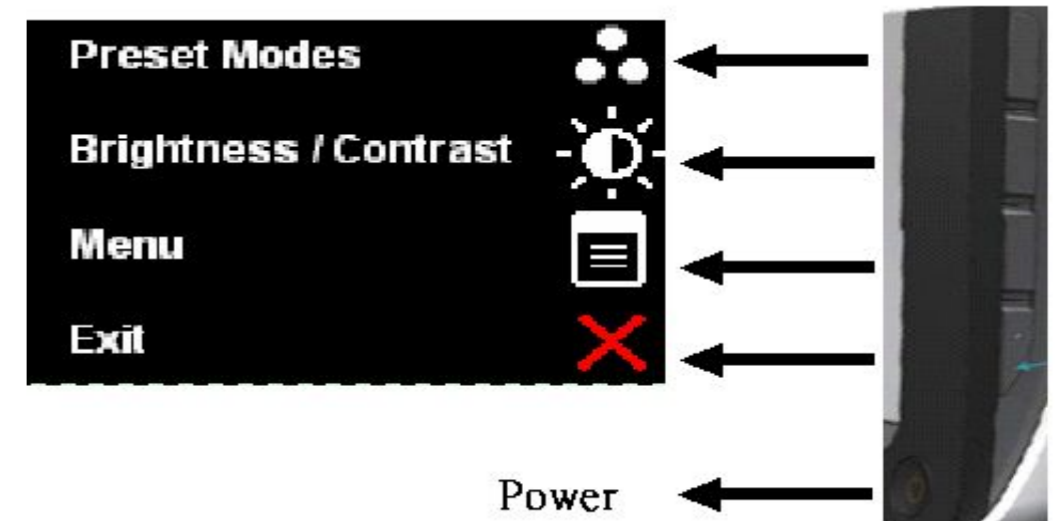
---



## Chapter 5- TEST AND ADJUSTMENT

### 5.1 Function key Definitions

Control buttons on the front bezel



#### 5.1.1 Control buttons on the front bezel

CONTROL KEY	KEYS FUNCTION
Personalize 1	Execute Personalize 1 function
Personalize 2	Execute Personalize 2 function
Menu	Enter main menu
Exit	Exit OSD
[POWER]	Power on or off the monitor

#### 5.1.2 Hot Key Operation

FUNCTION	HOT KEY OPERATION	DESCRIPTION
----------	-------------------	-------------



**Service Manual**

	[^]	[v]	MENU	Exit	POWER	
FACTORY MODE	•	•			ON	Press [[^]]& [v] at the same time, and power then press [POWER] for DC power on. Press the[^] key to enter factory menu

**5.2 OSD control**

First	Second	Third	Default	VGA Input	HDMI Input
Brightness / Contrast	Brightness		75	Yes	Yes
	Contrast		75	Yes	Yes
Auto Adjust	Press V to automatically adjust image			Yes	No
Input Source	Auto Select			Yes	Yes
	VGA				
	HDMI				
Color Settings	Input Color Format	RGB		Yes	Yes
		YPbPr			
	Mode Selection	Graphics			
		Video			
	Present Modes	Standard			
		Multimedia			
		Game			
		Warm			
		Cool			
		Custom(R,G,B)			
	Hue		50		
	Saturation		50		
	Demo Mode	Enable			
		Disable			
	Reset Color Settings				
Display Settings	Wide Mode	Fill		Yes	Yes
		4:3			
	Horizontal Position		50	Yes	No
	Vertical Position		50	Yes	No
	Sharpness		50	Yes	Yes
	Pixel Clock		50	Yes	No
	Phase			Yes	No
	Reset Display Settings			Yes	Yes
Other Settings	Language	English		Yes	Yes
		Espanol			
		Francais			
		Deutsch			
		Portugues(Brasil)			
		简体中文			
		日本語			

	Menu Transparency		20	Yes	Yes
	Menu Timer		20	Yes	Yes
	Menu Lock	Unlock		Yes	Yes
		Lock			
	DDC/CI	Enable		Yes	Yes
		Disable			
	LCD Conditioning	Disable		Yes	Yes
		Enable			
	Factory Reset			Yes	Yes
Personalize	Shortcutkey1	Preset Modes		Yes	Yes
		Brightness /Contrast		Yes	Yes
		Auto Adjust		Yes	No
		Input Source		Yes	Yes
	Shortcutkey2	Preset Modes		Yes	Yes
		Brightness /Contrast		Yes	Yes
		Auto Adjust		Yes	No
		Input Source		Yes	Yes

**In OSD dialog box, should show current input video signal (1Auto select, 2 VGA, 3 HDMI), current model resolution @ Ver. Freq., optimum resolution.**

### 5.3 OSD Message

After disconnecting the cable, Self Test message should show as below:



Press any OSD key and should show the input source (1. Auto Detect, 2 VGA,3 HDMI )dialog box on the right bottom of panel

After disabling the sync output for VGA (HDMI), DPMS message should show as below for 3s:

**“MESSAGE**

**Entering Power save Mode”**

Press any OSD key and the DPMS message should show as below:

**“MESSAGE**

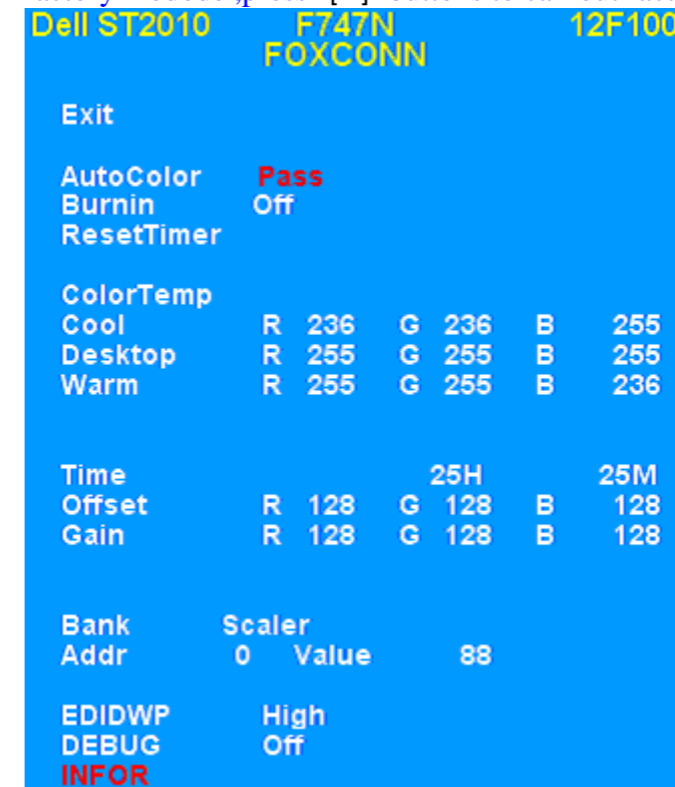
**There is no signal coming from you computer**

**Press any key on the keyboard or mouse to wake it or press the**

**Input button on your display to switch to another source**

Factory Mode Introduction

With signal input, press “Power” button on right corner of front bezel to turn off the monitor. Press first and second buttons on OSD key (from up to down) together, and then press “Power” button to turn on the monitor. After power on, the device is enter factory modode ,press “[▲]” buttons to call out factory menu (see the following Fig)



**Exit:** Exit from Factory mode and back to NO OSD Status.

**Panel:** The current-setting panel is highlighted.

**Auto Color:** Automatically calibrate chip ADC parameters by using internal DAC.

**Burn In:** Enable or disable the Burn-in mode by choosing ON or OFF.

**Reset Time:** Reset the “Turn-on time” of the panel to 0H0M.

**Color Temp:** The R, G, B of Blue Preset (9300K), Red Preset (5700K) and Normal Preset (6500K) are generated from scaling chip’s back-end white-balance program.

**Time:** Turn-on time of the panel.

**DEBUG:** Debug tool of scale IC U105.

**Dell panel P/N**

PANEL	Supplier P/N	CODE	PANEL
SAM	LTM200KT03	F747N	SAM

**5.4 Burn-in pattern**

Burn-in pattern will self-generate automatically without VGA and HDMI cable plugged in when the monitor set at Burn-in on mode and burn-in pattern will not be stopped until plugging in the VGA /HDMICable. Exit Burn-in mode method as followe: plugging in the VGA/HDMI cable, press “Menu” button to call out OSD Main Menu, Press “Plus Key”to select“Other Settings submenu”then choose Factory reset.

### **5.5 Auto Color Balance (Automatically calibrate chip ADC parameter by using chip internal DAC.)**

- 5.1 If it is a new-built set, press “*Auto/Plus*” button to execute “Auto Color” at standard video pattern 5-MOSAIC pattern
- 5.2 Please confirm the following steps to perform “Auto Color Balance”:
- Connect the VGA cable with the standard video pattern generator and display 5-MOSAIC pattern on the monitor.
  - press “*Power*” button on right corner of front bezel to turn off the monitor.
  - Press “*Menu*” and “+”(*Plus*) buttons together, and then press “*Power*” button to turn on the monitor. After power on, the device is enter factory modode ,press “-” buttons to call out factory menu
  - choose Auto Color item, then execute Auto Color item.
  - After the “Auto Color Balance” process finished, go back to “Other Settings Menu”, and press “Factory Reset” to exit Factory mode

### **5.6 Upgrade Firmware to Serial via Flash Cable by ISP\_Tool V4.100.exe**

Connect the monitor and PC follow Fig 11



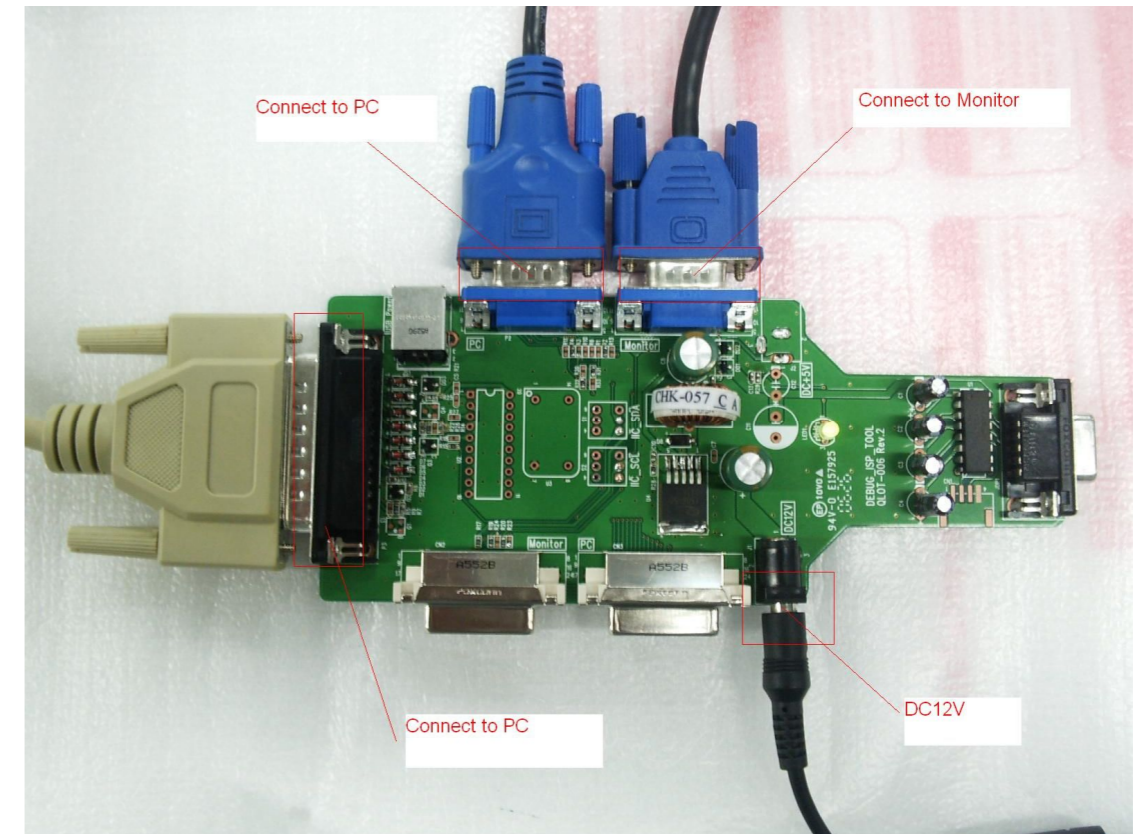





Fig 11

※ The detailed reprogramming procedures will be described in ISP User's Guide.


  
Edid 8.4.rar

  
Edid.rar

  
ISP User's Guide\_20070312.rar

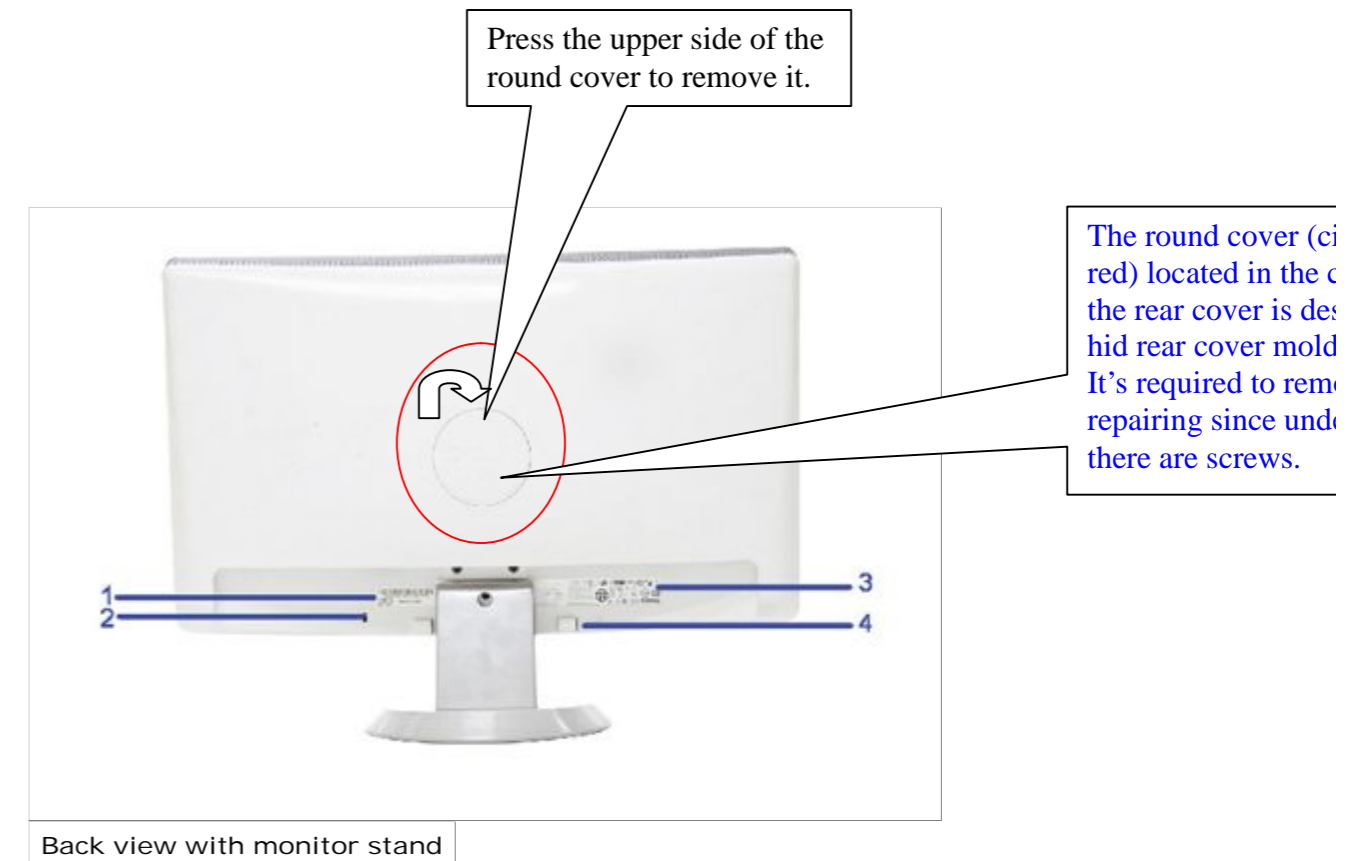
  
ISP\_Tool V4.100.rar

**After repair, to ensure the quality you should do the following test and adjustment.**

Item	Content	Equipment										
Test OSD function	1.Signal is set as 1280×1024@60Hz under General-1 2. LCM button are from left to right, checking whether each single function key and compound function key can be worked.	Chroma Signal Generator										
Contrast Check	1. Set input mode to 1600×900@60Hz 2. Set to 32gray scale pattern 3. Set contrast to the maximum. At most 6 bars cannot be distinguished.	Chroma Signal Generator										
Color Temperature	1. Do “Auto color Balance” at 1600×900@60Hz, 32gray scale pattern 2. Measure color temperature, check if it complies with the following temperature : Warm x=0.328 +/- 0.03, y=0.344+/-0.03 Desktop x= 0.313 +/- 0.03, y=0.329+/-0.03 Cool x= 0.283 +/- 0.03, y=0.298+/-0.03	Chroma Signal Generator and color analyzer										
Modes switching check	1. Use Chroma Pattern Generator to make sequence. VESA (640x480 800x600 1024x768 1152x864 1280x1024 1280×1024@60Hz,1600×900), the detail supported modes (see table 1) and power saving signal. 2. Confirm the above timing modes must be full screen and the picture must be normal. 3. LED is amber at power saving mode.	Chroma Signal Generator										
VGA cable detector	When select VGA model and VGA cable is not plugged out, self-test OSD will be floated.	Visual check										
Minimum luminance measurement	1. LCD Minimum luminance SPEC is 200cd/m2(0-15 months from mfg date) 2. 0-15 months:LUM>80% of SPEC minimum luminance	Chroma Signal Generator and Color Analyzer										
OSD Lock Test 	Soft Lock: When OSD is locked, this icon should appear for only 2 seconds with all buttons pressed, except for the “Menu” and “Power” ones. Hard Lock: Press “Menu” button for 15 seconds enables the “locked” icon to be displayed, which will lock All buttons expect for the “Power”. Press “Menu” button for another 15 seconds enables the “unlock” icon to be shown.	Visual Inspection										
Panel Flicker check	1. Mode:1600×900@60Hz 2. Set Brightness& Contrast to default value (75%) 3. Do “Auto Adjustment” 4. check whether there’s flicker on the center of the picture.	Equipment:: Chroma Signal Generator & PC										
Power saving	1. Mode:1600x900@60Hz 2. Pattern: full Black 3. Brightness: Max. 4. Contrast: Default 5. Check power consumption at each modes <table border="1" data-bbox="1822 1801 2549 2051"> <thead> <tr> <th>State</th> <th>Power Consumption</th> <th>LED color</th> </tr> </thead> <tbody> <tr> <td rowspan="2">Normal</td> <td>&lt; 30W(with full load)</td> <td rowspan="2">white</td> </tr> <tr> <td>&lt; 30W</td> </tr> <tr> <td>Stand By</td> <td>&lt; 1W</td> <td>Amber</td> </tr> </tbody> </table>	State	Power Consumption	LED color	Normal	< 30W(with full load)	white	< 30W	Stand By	< 1W	Amber	Chroma signal generator and Power meter AC input:230V/50Hz
State	Power Consumption	LED color										
Normal	< 30W(with full load)	white										
	< 30W											
Stand By	< 1W	Amber										

## Chapter 6- TROUBLE SHOOTING

Remark:



### 1. Common Acknowledge

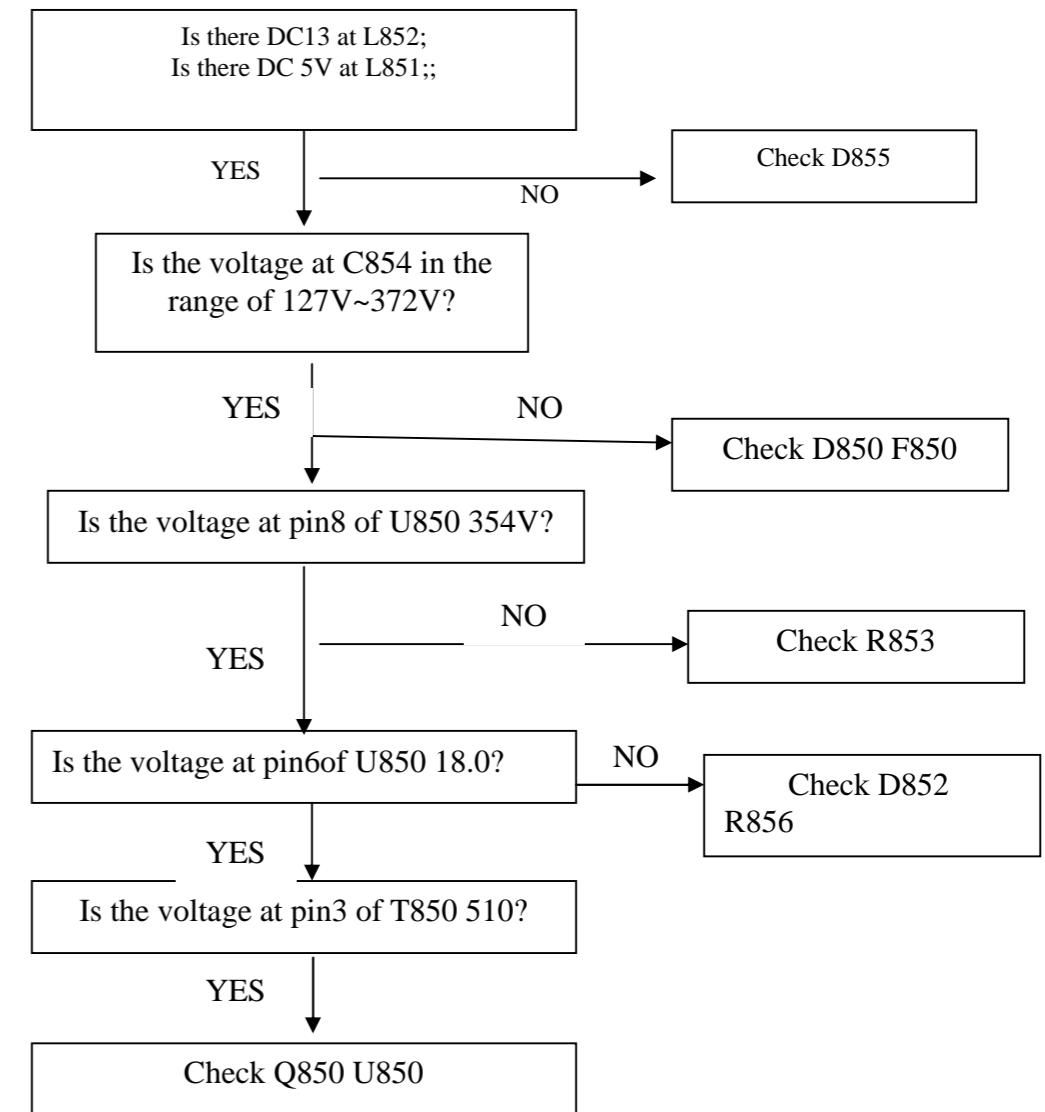
- If you change the M/B, be sure that the U103,U204 and U108 these three components also changed to the new M/B because there was program inside. If not, please re-write EDID or upload firmware into serial flash(U108) via VGA Cable. How to do please refer to the Page 19.
- If you adjust clock and phase, please do it at condition of Windows shut down pattern.
- Please confirm the R/G/B color under 32gray scale pattern.
- This LCM is analog interface. So if the entire screen is an abnormal color that means the problem happen in the analog circuit part, if only some scale appears abnormal color that stand the problem happen in the digital circuit part.
- If you check the H/V position, please use the crosshatch pattern.
- This LCM support 10 timing modes, if the input timing mode is out of specification, "Cannot Display this Video Mode" will be displayed on the screen.
- If brightness uneven, repairs Inverter circuit or change a new panel.
- If you find the vertical line or horizontal line lost on the screen, please



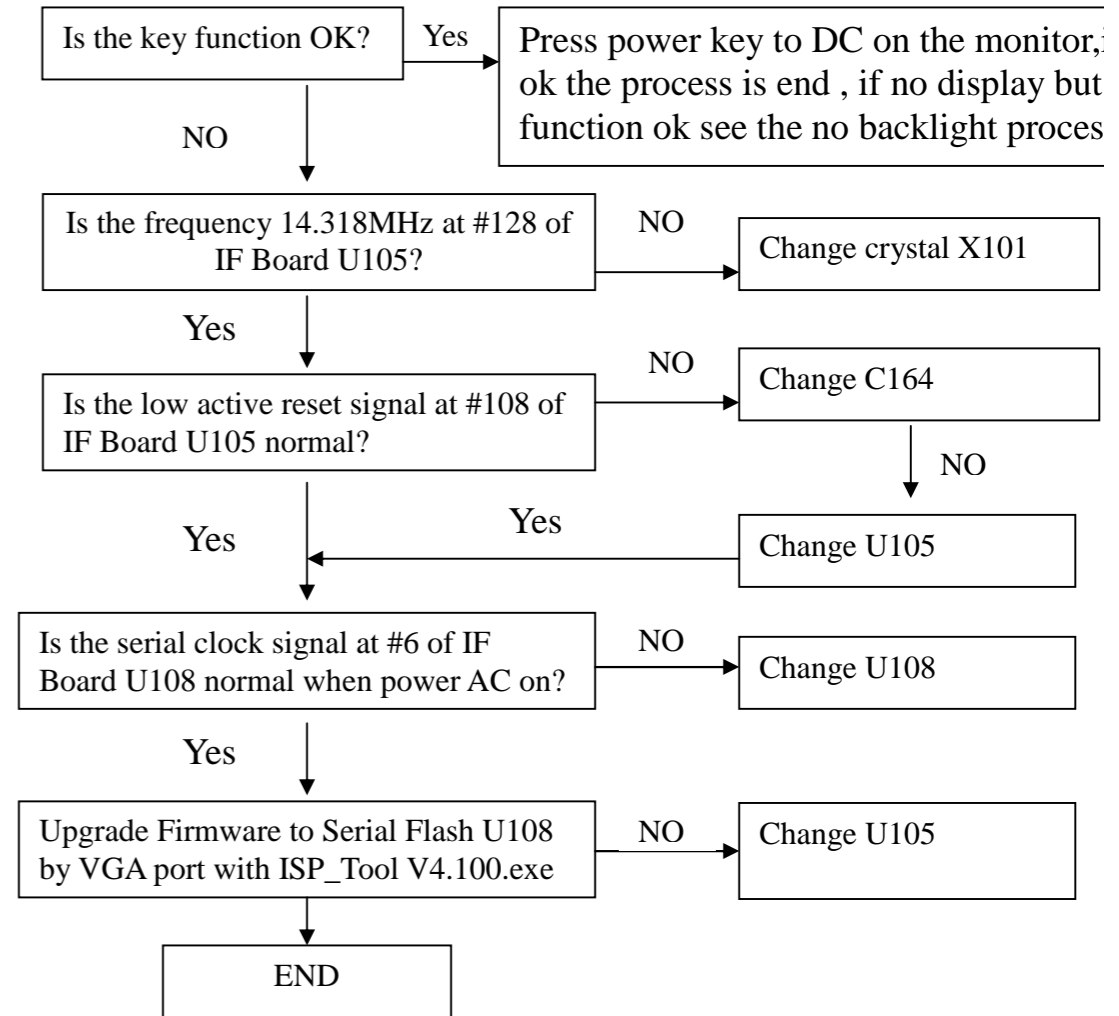
change panel.

- If the self-test pattern is moving on the screen, please check whether VGA Cable is plugged in the Monitor or PC if select analog model on OSD or check whether HDMI Cable is plugged in the Monitor or PC if select HDMI model on OSD . If the VGA or HDMI Cable is plugged in well, please change another VGA or HDMI cable.

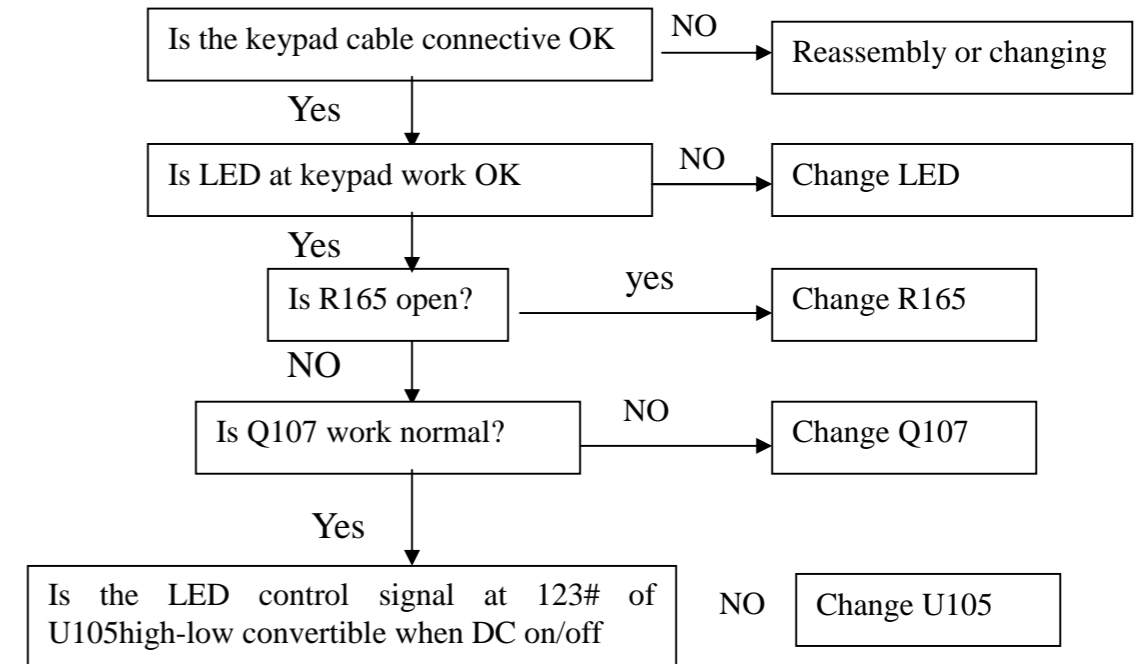
**2. No power supply**

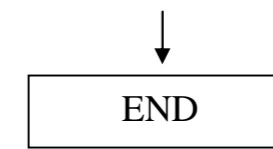


**3. Power (include IF +5V and +3.3V) supply normal but LED off and no display**

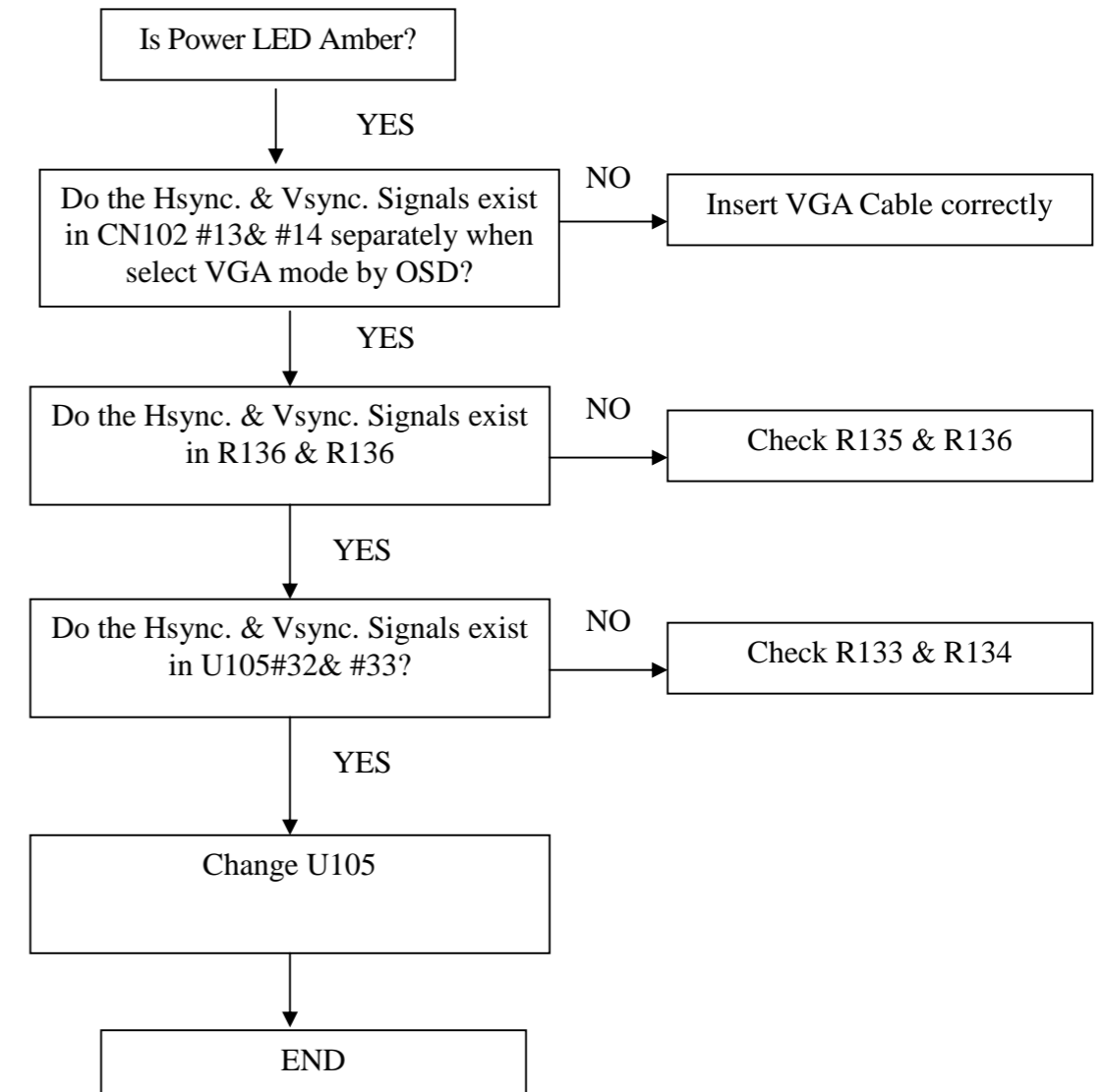


**4. Power (include IF +5V and +3.3V) supply and display normal only LED off**

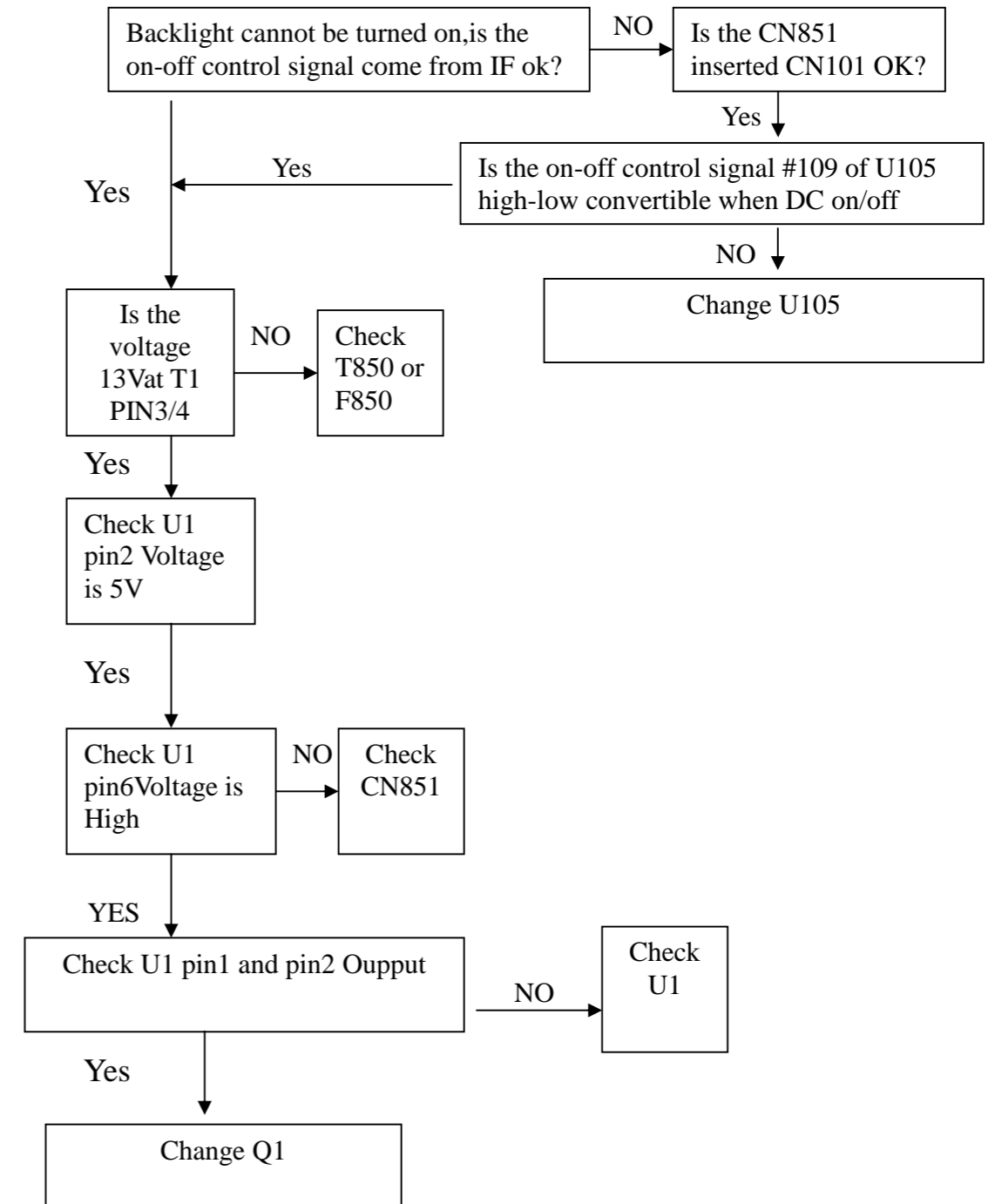




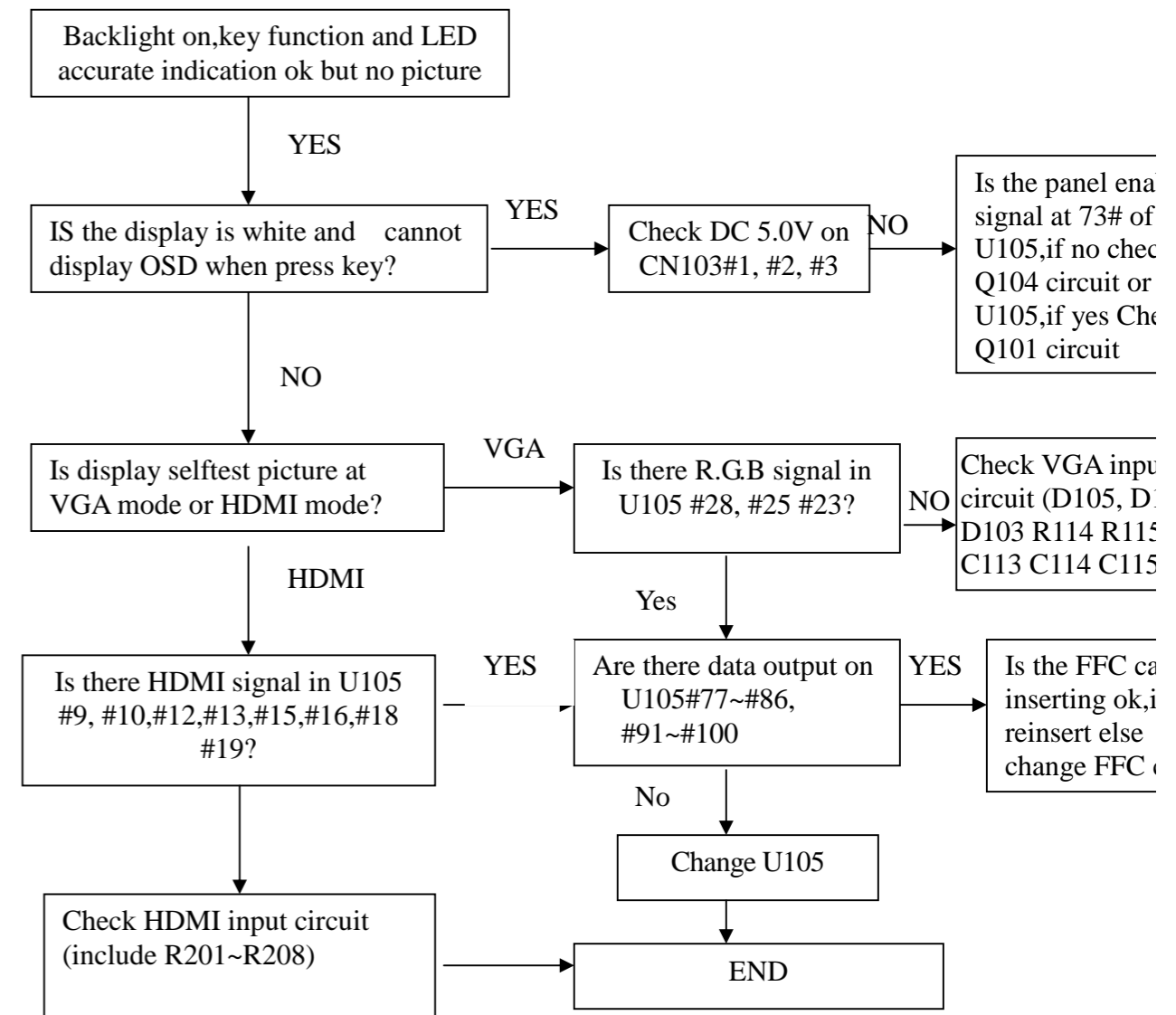
**5. Power (include IF +5V and +3.3V) supply normal but LED Amber**



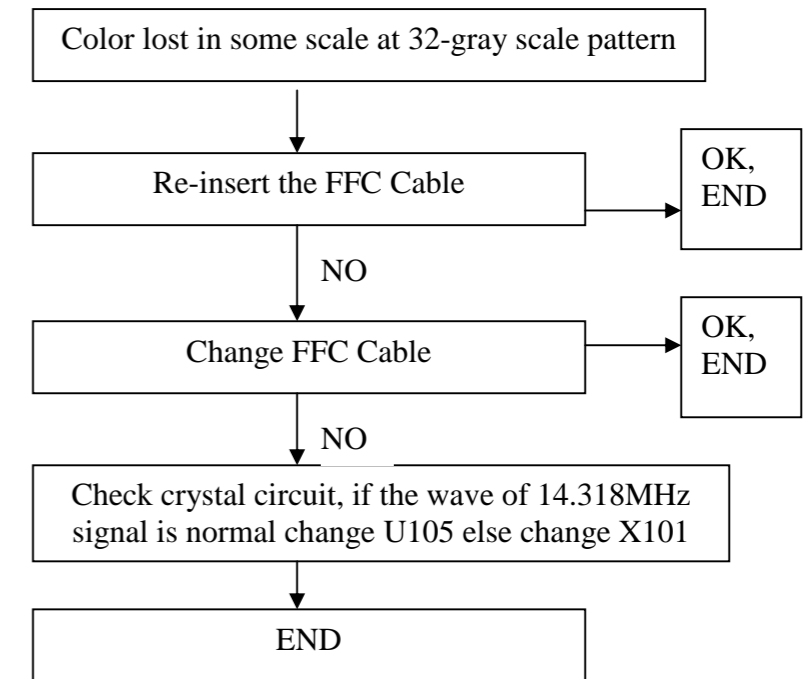
**6. Power (include IF +5V and +3.3V) supply normal ,key function OK, but backlight can't be turned on**



**7. Backlight on, key function and LED accurate indication ok but no picture**



**8. At 32-gray scale pattern, color lost in some scale**



**Chapter 7- RECOMMENDED PART LIST**

**ST2010 Critical Parts List**

**ST2010 Critical Parts List**

Item	Category	Component Type	Location	Supplier	Component number	Supplier PN	Object description	Purpose
PI BD	Function	Power Control IC	U850	LEADTREND,	412000453820R	LD7575	IC LD7575PS SOP8(LEADTREND) RoHS	PWM Control IC for Power
	Function	Inverter Control IC	U1	O2	412000783630R	INL816	IC INL816GN SOP16(O2 MICRO)	PWM Control IC for Inverter
	Critical	Power Transformer	T850	FOXCONN, FRONTIER LISHIN MEIKAI,	426000091190R	2MWWA2828-006A SRH2820-08-LFR PFK8018EL BCK-2853	XFMR SW DIP ER28 TP4 920uH SPW-119 ROHS	Transfer AC to 5V/13V
	Critical	Inverter Transformer	T1	DARFON FOXCONN TDK FRONTIER LISHIN,	426000090540R	TK2025M101 2MVLA1905-001A NIA19LES-X69H03 SEH1947-03-LFR IFK7015HL	XFMR SW 955mH,SPW-054,RoHS	High-vol. transformer for CCFLs
	Critical	Aluminium Electrolytic Cap.	C854	ELITE SAMXON LELON SU'SCON,	420431014083R	PW2W101MSG1840R EKMXXMXXXXXX--P PGAXXXMXXX-XXXXT SK450M101K40T022LCCR	CAP SEK 100uF/450V M,105°C CF,18x40(2.5)	Filter AC line voltage to DC
	Critical	Power MOS	Q850	APEC, FUJI, ST,	410050114290R 410050103050R 410050057280R	AP2764 FMA09N65GX STP8NK80ZFP	XSTR AP2764AI-A N-CH 650V/9A TO-220CFM XSTR FMA09N65GX N-CH TO-220F(FUJI) RoHS XSTR STP8NK80ZFP N-CH TO220FP (ST)	Switch MOS
	PCB	PCB		HSIANGKUO TATCHUN,	492411400100R	PCB	PCB,P/I ,1/OSP /CEM1/16, LE20Q5,ROHS	PCB
	PCB	PCB		EXPRESS TOP FAITH	492422200000H	PCB	PCB,CRL-I ,2/OSP /FR4/12(INL816)LE19S1,H	PCB
	PCB	PCB		GOODWELL WELFARE,	490712100200R	PCB	PCB,CONTROL(PWR LD7575),LE1521	PCB



**Service Manual**

I/F Board	Performance	EEPROM	U103,U204	CATALYST	412000480990R	CAT24FC02WI-TE13	IC CAT24C02WI-TE13 SOIC-8(CATALYST)RoHS	EEPROM
				A1SEMI	412000769830R	AS24C02T 2K	IC AS24C02T 2K SOIC8(A1SEMI)RoHS	
				ST	412000480280R	M24C02-WMN6TP	IC M24C02-WMN6TP SO8 2K (ST)	
				ATMEL	412000435481R	AT24C02BN-SH-T 2K	IC AT24C02BN-SH-T 2K SOIC8(ATMEL)RoHS	
	Performance	EEPROM	U106	ATMEL	412000224482R	AT24C16BN-SH-T	IC AT24C16BN-SH-T 16K(ATMEL) SOIC 8 ROHS	EEPROM
				ST	412000224280R	M24C16-WMN6TP	IC M24C16-WMN6TP SO8 16K (ST) ROHS	
				CATALYST	412000481990R	CAT24C16WI-TE13	IC CAT24C16WI-TE13 SOIC-8(CATALYST)RoHS	
	Critical	Regulator	U101	ANACHIP,	412000332130R	AP1117D33LA 3.3V	IC AP1117D33LA 3.3V (ANACHIP) TO-252-3L,	DC to DC convert
				AME	412000241550R	AME1117CCCTZ 3.3V	IC AME1117CCCTZ 3.3V,TO-252(AM E)RoHS	
				UTC	412000332020R	LD1117AL-3.3-A	IC LD1117AL-3.3-A TO-252(UTC)RoHS	
				AISEMI,	412000332830R	AS1117R-3.3.TR-LF,	IC AS1117R-3.3.TR-LF,TO-252(A1 SEMI)RoHS	
	Critical	Regulator	U102	E-CMOS	412000599990H	EC50117BBG 1.8V	IC EC50117BBG 1.8V SOT223(E-CMOS)	DC to DC convert
				UTC	412000330020R	LD1117AL-1.8V-A	IC LD1117AL-1.8V-A SOT223(UTC)	
				A1-SEMI	412000330830R	AS1117L-1.8/TR	IC AS1117L-1.8/TR-LF,SOT223(A1	
				BCD,	412000330070R	AZ1117H-1.8	IC AZ1117H-1.8 SOT223(AAC)RoHS	
	Function	Serial Flash	U108	SST	412000494190R	SST25LF020A-33-4C-SAE	IC SST25LF020A-33-4C-SAE SOIC8(SST)ROHS	FW storage
				MXIC	412000661620R	MX25L2025MC-12G	IC MX25L2025MC-12G SOP8(MXIC)RoHS	
				PMC	412000494310R	PM25LV020-100SCE	IC PM25LV020-100SCE SOIC8(PMC)RoHS	
Function	Scaler	U105	MSTAR	412000722062R	TSUMU58EDJ-LF-2	IC TSUMU58EDJ-LF-2 PQFP128)Rohs	Scaler	
Function	connector	CN103	CVILUX	444099030040R	C11330MG	CON, SMD 1.0MM 30PIN with lock RoHS	LVDS Cable Connector	
			P-TWO		HS9030E			
PCB	PCB		EXPRESS	492411300100R	PCB	PCB,I/F ,2/OSP /FR4 /16,LE20Q5,RoHs	PCB	
			SHENGHUA					
PCB	PCB		EXPRESS	492411500010R	PCB	PCB,K/OSD,2/OSP /FR4 /16,LE20Q5,RoHs	PCB	
			SHENGHUA					
PCB	PCB		SHENGHUA EXPRESS	492411500000R	PCB	PCB,K/PWR,2/ENIG/FR4 /08,LE20Q5,RoHs	PCB	

**ATTACHMENT 1- Bill of Material**

**1. Power board BOM**





**Service Manual**

ITEM	Phant.item	P/N	Description	Supplier
		792821400800R	PCBA,P/I BOARD,W/O SPK,LE20Q5-817 ROHS	
10	x	792821420800R	PCBA,P/I BOARD,W/O SPK,MI,LE20Q5-817 RO	
20		792821410800R	PCBA,P/I BOARD,W/O SPK,AI,LE20Q5-817 RO	
30		792552100B00R	PCBA,CONTROL/B(PWR LD7575),LE20P9 RoHS	
40		792812200700R	PCBA,CONTROL/B(INV INL816),LE19S1, RoHS	
50	x	735110010900R	ASSY,H/S,Q850, LP20P9,ROHS	
60		511130001200R	SOLDER BAR,Sn96.5/Ag3.0/Cu0.5/Ni0.06/Ge0	TOMAS,
70		511110000501R	SILICONE RTV RUBBER,UB-511(EURO)	EURO,
80		511110000103R	HOT-MELT ADHESIVES,UB-618	U-BOND,
80		511110000101R	HOT-MELT ADHESIVES (#526)	EXCELSTAR,
###				
ITEM	Phant.item	P/N	Description	Supplier
		735110010900R	ASSY,H/S,Q850, LP20P9,ROHS	
10		410050103050R	XSTR FMA09N65GX N-CH TO-220F(FUJI) RoHS	FUJI,
10		410500059290R	XSTR AP27611-A N-CH TO-220CFM ADVANCED P	APEC,
10		410050057280R	XSTR STP8NK80ZFP N-CH TO220FP (ST)	ST,
10		410050114290R	XSTR AP2764AI-A N-CH 650V/9A TO-220CFM	APEC,
20		507300003300R	HEATSINK,"L", LE1713/1913	DMC,ORIENTAL POWER,ZHONGJIAN,
30		509146306200R	SCREW,P,CROSS,W/WAS,M3*6,Zn-Cc	GAOYI,YIJIE,
###				
ITEM	Phant.item	P/N	Description	Supplier
		792552100B00R	PCBA,CONTROL/B(PWR LD7575),LE20P9 RoHS	
10		430632080020R	WFR. 8P 2.54mm 90°,HEADER,W/O PIN2,RoHS	CVILUX,FOXCONN,JOWLE,
20		792552140B00R	PCBA,CONTROL/B(PWR LD7575),SMD,LE20P9 R	
30		511130001200R	SOLDER BAR,Sn96.5/Ag3.0/Cu0.5/Ni0.06/Ge0	TOMAS,
###				
ITEM	Phant.item	P/N	Description	Supplier
		792812200700R	PCBA,CONTROL/B(INV INL816),LE19S1, RoHS	
10		430632150010R	WFR. 15P 2.54mm 90°,HEADER,RoHS	CVILUX,FOXCONN,
20		792812240700R	PCBA,CONTROL(INV INL816),SMD,LE19S1,ROHS	
30		511130001200R	SOLDER BAR,Sn96.5/Ag3.0/Cu0.5/Ni0.06/Ge0	TOMAS,



## Service Manual

###	ITEM	Phant.item	P/N	Description	Supplier
			792821410800R	PCBA,P/I BOARD,W/O SPK,AI,LE20Q5-817 RO	
	10	x	792821450800R	PCBA,P/I BOARD,W/O SPK,AI/A,LE20Q5-817	
	20	x	792821460800R	PCBA,P/I BOARD,W/O SPK,AI/R,LE20Q5-817	
###	ITEM	Phant.item	P/N	Description	Supplier
			792821420800R	PCBA,P/I BOARD,W/O SPK,MI,LE20Q5-817 RO	
	10		430637020030R	WFR. 2P P=3.5mm 90°W/LOCK,RoHS	CVILUX,FCN,FOXCONN,
	20		440149000350R	SKT AC 10A/250V U/C/V, H 1.0MM ROHS	TECX,
	30		418112051520R	CAP CD NPO 12pF 3KV J,S7.5, RoHS	JNC,SUCCESS(SEC),
	30		418112058520R	CAP CD SL 12pF 3KV J,S7.5,RoHS	JNC,SUCCESS(SEC),
	40		418103051920R	CAP CD NPO 3pF 3KV D,S7.5, RoHS	JNC,SUCCESS(SEC),
	40		418103058920R	CAP CD SL 3pF 3KV D,S7.5,RoHS	JNC,SUCCESS(SEC),
	50		416202223620R	CAP MEY 2200pF 250V M Y2 Y5V,W /O FORMIN	JNC,POE,SUCCESS(SEC),WANSHENG,
	60		416194743011R	CAP MEX 0.47uF 275V K X2,F15 RoHS	ARCOTRONIC,EUROPTRONIC,HJC,SCC,
	70		420431014083R	CAP SEK 100uF/450V M,105°C CF,18x40(2.5)	ELITE,LELON,SAMXON,SU'SCON,
	80		416213323620R	CAP MEY 3300pF 250V M Y1,F10mm W/O FORMI	JNC,POE,SUCCESS(SEC),WANSHENG,
	90		416304723510R	CAP PP 0.0047uF 250V J,F7.5 RoHS	EUROPTRONIC,HJC,SCC,
	100		415502688551R	RES NKNP 2W 0.68Ω J, MINI, HK15, ROHS	FUTABA,QUEENMAO,TZAI YUAN,UNIOHM,欣
	110		415350100550R	RES MOF 2W 10Ω J, MINI, HK15, RoHS	FUTABA,QUEENMAO,TZAI YUAN,UNIOHM,欣
	120		415350823550R	RES MOF 2W 82KΩ J, MINI, HK15 RoHS	FUTABA,QUEENMAO,TZAI YUAN,UNIOHM,欣
	130		432009400701R	NTC 5Ω 4A 10ψ P=5mm, F RoHS	THINKING,UPPERMOST,
	140		412140002380R	IC LTV817M-PR VDE (LITE-ON) P=10mm RoHS	LITEON,
	140		412000756150R	IC PS2561AL1-1-V-A D10(NEC)	NEC,
	150		425000010530R	COIL CHK 5uH 7.8X10 CHK-053 0 181085R0L	CHILISIN,DARFON,EASYMAGNET,FOXCONN,I
	160		426000050070R	CHOKE L-FILTER 12mH LIN-007 ET-20,RoHS	DARFON,FOXCONN,LISHIN,MEIKAI,TAICHANG
	170		411050012010R	DIO BRDG GBU405 600V/4A(TSC)RoHS	TSC,
	170		411050012020R	DIO BRDG GBU4-06-BF52 600V/4A(FEC)RoHS	FRONTIER,
	180		411090056022R	SCHTKYSR520F75-LF 200V/5A DO-201AD(FEC)	FRONTIER,
	180		411090056452R	SCHTKYSR5200PT-A3 200V/5A DO-201AD(CHENM)	CHENMKO,
	190		411090050022R	SCHTKY SR515F75-LF 150V/5A DO-201AD(FEC)	FRONTIER,
	190		411090050012R	SCHTKY SR5150PT-A3 150V/5A DO-201AD (CH)	CHENMKO,
	200		426000090540R	XFMR SW 955mH,SPW-054,RoHS	DARFON,FOXCONN,FRONTIER,LISHIN,TDK,
	210		426000091190R	XFMR SW DIP ER28 TP4 920uH SPW-119 ROHS	FOXCONN,FRONTIER,LISHIN,MEIKAI,
	220		430300801650R	HRN ASS'Y 8P 130mm UL1007 24 AWG ROHS	FOXCONN,HEIGHTEN,JVE,



### Service Manual

###	ITEM	Phant.item	P/N	Description	Supplier
			792552140B00R	PCBA,CONTROL/B(PWR LD7575),SMD,LE20P9 R	
	10		419312210060R	C SMD(0603) X7R 220PF/50V K RoHS	DARFON,TDK,WALSIN,YAGEO,
	20		419311040060R	C SMD(0603) X7R 0.1uF/50V K RoHS	DARFON,TDK,WALSIN,YAGEO,
	30		419311020060R	C SMD(0603) X7R 1000PF/50V K RoHS	DARFON,TDK,WALSIN,YAGEO,
	50		414904020350R	RES SMD (1206) 20KΩ J,RT RoHS	TA-I,UNIOHM,WALSIN,YAGEO,
	60		414916010410R	RES SMD (0603) 100K F,RT RoHS	TA-I,UNIOHM,WALSIN,YAGEO,
	70		414916200910R	RES SMD (0603) 20Ω F,RT,RoHS	TA-I,UNIOHM,WALSIN,YAGEO,
	80		414916022150R	RES SMD (0603) 220Ω J,RT RoHS REV:A	TA-I,UNIOHM,WALSIN,YAGEO,
	90		412000453820R	IC LD7575PS SOP8(LEADTREND) RoHS	LEADTREND,
	110		490712100200R	PCB,CONTROL(PWR LD7575),LE1521	GOODWELL,WELFARE,
	120		511130002200R	SOLDER PASTE,TYPE3,2045,Sn96.5%Ag3%Cu0.5	TOMAS,
	120		511130002201R	SOLDER PASTE,TYPE4,2038,Sn96.5%Ag3%Cu0.5	TOMAS,
###					
###	ITEM	Phant.item	P/N	Description	Supplier
			792812240700R	PCBA,CONTROL(INV INL816),SMD,LE19S1,ROHS	
	10		419311053070R	C SMD(0805) X7R 1UF/25V K ROHS REV:A	DARFON,TDK,WALSIN,YAGEO,
	10		419311054070R	C SMD(0805) X7R 1uF/16V K RoHS REV:A	DARFON,TDK,WALSIN,YAGEO,
	20		419311020060R	C SMD(0603) X7R 1000PF/50V K RoHS	DARFON,TDK,WALSIN,YAGEO,
	30		419312254070R	C SMD(0805) X7R 2.2uF 16V K RoHS	DARFON,MURATA,TAIYO,TDK,WALSIN,YAGEO,
	40		419314730060R	C SMD (0603) X7R 0.047uF 50V,K RoHS	DARFON,TDK,WALSIN,YAGEO,
	50		419312720060R	C SMD(0603) X7R 2700PF/50V K RoHS	DARFON,TDK,WALSIN,YAGEO,
	60		419313320070R	C SMD(0805) X7R 3300PF/50V K RoHS	DARFON,TDK,WALSIN,YAGEO,
	70		411020047210R	DIO BAV70 85V SOT23 (PHILIPS) RoHS	PHILIPS,
	70		411020047020R	DIO BAV70-LF, 70V SOT-23(FEC) ROHS	FRONTIER,
	80		410500070290R	XSTR AP9971GM,N-CH,SO8(APEC) RoHS	APEC,
	80		410050071380R	XSTR AM9945N-T1-PF N-CH,SO8(AP)RoHS	AP,
	90		414908100910R	RES SMD(0805)10Ω F,RT ROHS	TA-I,UNIOHM,WALSIN,YAGEO,
	100		414908010350R	RES SMD (0805) 10KΩ J,RT RoHS REV:A	TA-I,UNIOHM,WALSIN,YAGEO,
	110		414916560310R	RES SMD (0603) 560KΩ F,RT,RoHS	TA-I,UNIOHM,WALSIN,YAGEO,
	120		414916191310R	RES SMD (0603) 191KΩ F,RT,RoHS	TA-I,UNIOHM,WALSIN,YAGEO,
	130		414916010450R	RES SMD (0603) 100KΩ J,RT REV:A RoHS	TA-I,UNIOHM,WALSIN,YAGEO,
	140		414916330210R	RES SMD (0603) 33KΩ F,RT RoHS	TA-I,UNIOHM,WALSIN,YAGEO,
	150		414904200910R	RES SMD (1206) 20Ω F,RT ROHS	TA-I,UNIOHM,WALSIN,YAGEO,
	160		412000783630R	IC INL816GN SOP16(O2 MICRO)	O2,
	170		492422200000H	PCB,CRL-I ,2/OSP /FR4/12(INL816)LE19S1,H	EXPRESS,SHENG HUA,
	180		511130002200R	SOLDER PASTE,TYPE3,2045,Sn96.5%Ag3%Cu0.5	TOMAS,
	180		511130002201R	SOLDER PASTE,TYPE4,2038,Sn96.5%Ag3%Cu0.5	TOMAS,
###					



## Service Manual

ITEM	Phant.item	P/N	Description	Supplier
		792821450800R	PCBA,P/I BOARD,W/O SPK,AI/A,LE20Q5-817	
10		411032006020R	DIO FR10-10-LF 1000V/1A AT(FRO NTIER)RoH	FRONTIER,
10		411032006040R	DIO FR107 1000V/1A DO-41(MOSPE C)RoHS	MOSPEC,
10		411020053090R	DIO PS1010R 1000V/1A DO-41(PAN JIT)RoHS	PANJIT,
20		411020064090R	DIO ER104 400V/1A DO-41(PANJIT RoHS	PANJIT,
20		411032001020R	DIO SF10-04-LF 400V/1A DO-41(F RONTIER)R	FRONTIER,
30		411020080090R	DIO P6KE170A 600W/100A DO-15 ( PANJIT )	PANJIT,
30		411020080460R	DIO P6KE170A 600W/100A DO-15 ( SECOS )	SECOS,
30		411020080020R	DIO P6KE170A-LF 600W/100A DO-15(FEC)	FRONTIER,
40		430613050100R	FUSE SLOW PICO II 5A/125V U/C,AT,ROHS	LITTELFUSE,
40		430613050101R	FUSE SLOW 5A/125V U/C,AT,ROHS	WALTER,
60		415211330140R	RES MF 1/8W 133Ω F,AT,RoHS	QUEENMAO,TZAI YUAN,UNIOHM,欣統,
70		415237503140R	RES MF 1/2W 750KΩ F AT MINI,ROHS	QUEENMAO,TZAI YUAN,UNIOHM,欣統,
80		415213301140R	RES MF 1/8W 3.3KΩ F,AT,RoHS	QUEENMAO,TZAI YUAN,UNIOHM,欣統,
90		415213601140R	RES MF 1/8W 3.6KΩ F,AT ,ROHS	QUEENMAO,TZAI YUAN,UNIOHM,欣統,
100		415221009140R	RES MF 1/4W 10Ω F,AT MINI,ROHS	QUEENMAO,TZAI YUAN,UNIOHM,欣統,
110		415222700140R	RES MF 1/4W 270Ω F,AT,MINI,ROHS	QUEENMAO,TZAI YUAN,UNIOHM,欣統,
120		415211002140R	RES MF 1/8W 10KΩ F,AT RoHS	QUEENMAO,TZAI YUAN,UNIOHM,欣統,
130		415215101140R	RES MF 1/8W 5.1KΩ F,AT,RoHS	QUEENMAO,TZAI YUAN,UNIOHM,欣統,
140		415212703140R	RES MF 1/8W 270KΩ F,AT,RoHS	QUEENMAO,TZAI YUAN,UNIOHM,欣統,
150		414040208540R	RES FSM 1W 0.2Ω J,AT MINI RoHS	FUTABA,QUEENMAO,TZAI YUAN,UNIOHM,欣統,
160		430405000000R	JMPR ROLL/KG D=0.6mm,AT,RoHS 7.5MM	HOTRON,YUANYE,
160		430405000000R	JMPR ROLL/KG D=0.6mm,AT,RoHS 7.5MM	HOTRON,YUANYE,
170		430405000000R	JMPR ROLL/KG D=0.6mm,AT,RoHS 10MM	HOTRON,YUANYE,
170		430405000000R	JMPR ROLL/KG D=0.6mm,AT,RoHS 10MM	HOTRON,YUANYE,
180		492411400100R	PCB,P/I ,1/OSP /CEM1/16, LE20Q5,ROHS	HUIHO,TATCHUN,
190		506140005700R	LABEL,BARCODE,BLANK,33x7mm, ROHS,FOR PCB	HENGMINGDA,JIAYINMEI,KAIDA,
###				
ITEM	Phant.item	P/N	Description	Supplier
		792821460800R	PCBA,P/I BOARD,W/O SPK,AI/R,LE20Q5-817	
10		420221000530R	CAP HG 10uF 50V M,105°C VT,5x11,RoHS	LELON,SAMXON,SU'SCON,
20		420426810261R	CAP SD 680UF/25V M 105°C ST 10X20 ROHS	LELON,SAMXON,SU'SCON,
30		420424710260R	CAP SD 470uF/25V M 105°C ST 10x16,RoHS	LELON,SAMXON,SU'SCON,
40		418210233030R	CAP CD X7R 1000pF/1KV K,VT 2X7R102K102K5	JNC,POE,SUCCESS(SEC),WANSHENG,
50		418210313030R	CAP CD X7R 0.01UF 50V K,VT,ROHS	JNC,POE,SUCCESS(SEC),WANSHENG,
60		419111040030R	CAP MTL X7R 0.1uF 50V K,VT, RoHS	JNC,POE,SUCCESS(SEC),WANSHENG,
70		430613830290R	FUSE TIME LAG 3.15A/250V,RoHS	BELFUSE,CONQUER,LITTELFUSE,WALTER,
80		412022002240R	IC KA431AZ 1%,VT (FAIRCHILD) RoHS	FAIRCHILD,
80		412022002550R	IC AME431BAJATB25Z TO-92-3(AME RoHS	AME,
80		412022002830R	IC AS431 TO-92 VT(A1SEMI)RoHS	A1SEMI,
80		412022002440R	IC AS431BZTR-E1 TO-92(BCD) RoHS	BCD,

## 2. Interface board BOM



**Service Manual**

ITEM	P/N	Description	Supplier	Usage	Un	Location	Rev
	792821300800R	PCBA,I/F BOARD,W/O SPK,LE20Q5-817					AA
10	792821320800R	PCBA,I/F BOARD,W/O SPK,MI,LE20Q5		1	PC		AA
20	792821340800R	PCBA,I/F BOARD,W/O SPK,SMT,LE20Q5-		1	PC		AA
30	629030029300R	PROGRAM,W/O SPK,LE20Q5-817 ROHS		1	PC		0
40	511130001200R	SOLDER BAR,Sn96.5/Ag3.0/Cu0.5/Ni0.06/Ge0	TOMAS,	2.6	G		A
ITEM	P/N	Description	Supplier	Usage	Un	Location	Rev
	792821320800R	PCBA,I/F BOARD,W/O SPK,MI,LE20Q5-817					AA
10	430631080210R	WFR 8P 2.0MM 90° W/LOCK ROHS	CVILUX,FOXCONN,	1	PC	CN101,	A
20	440819015030R	CON D-SUB FEM.15P RA W/O SCREW DZ	DLK,FOXCONN,TEKCON,ZJGHJ,	1	PC	CN102,	A
30	430631080220R	WFR 2X4P 2.0MM 90° W/LOCK ROHS	CVILUX,FOXCONN,	1	PC	CN104,	A
40	432008010270R	XTAL 14.31818MHz HC-49US DIP 16pF 30PPM	HUAN MOUN,TXC,ZGC,	1	PC	X101,	A
50	420421010440R	CAP SD 100uF 16V M,105°C VT2.5,5x 11,ROH	LELON,SAMXON,SU'SCON,	3	PC	C101,C102,C109,	A
70	420434700440R	CAP EC 47UF 16V M,105°C VT2.5 5X11 ROHS	ELITE,LELON,SAMXON,SU'SCON,	3	PC	C103,C142,C150,	A
80	420434790440R	CAP EC 4.7UF/16V M 105°C,VT2.5,5X1 1,ROH	ELITE,LELON,SAMXON,SU'SCON,	1	PC	C112,	A
ITEM	P/N	Description	Supplier	Usage	Un	Location	Rev
	792821340800R	PCBA,I/F BOARD,W/O SPK,SMT,LE20Q5					AA
20	443499019010R	CON HDMI SMD 19P 0.5mm R/A , QJ51	DLK,	1	PC	CN201,	A
20	443499019011R	CON HDMI SMD 19P 0.5MM R/A ,ROHS	FOXCONN,	0	PC		A
30	444099030040R	CON, SMD 1.0MM 30PIN with lock RoHS	CVILUX,P-TWO,	1	PC	CN103,	A
40	419351044010R	C SMD(0402) X5R 0.1uF/16V K,RoHS	DARFON,MURATA, TAIYO,TDK,WALSIN,YAGEO,	44	PC	C106,C107,C108,C110, C111,C122,C123,C124, C125,C126,C127,C128, C133,C134,C135,C136, C137,C138,C139,C140, C141,C143,C144,C145, C146,C147,C149,C153, C154,C155,C156,C159, C160,C161,C165,C167, C168,C169,C170,C171, C201,C204,C205,C104,	A
50	419311020010R	C SMD(0402) X7R 1000PF/50V K,RoHS	DARFON,TDK,WALSIN,YAGEO,	1	PC	C174,	A
60	419311054070R	C SMD(0805) X7R 1uF/16V K RoHS REV:A	DARFON,MURATA, TAIYO,TDK,WALSIN,YAGEO,	1	PC	C164,	A
70	419314734010R	C SMD(0402) X7R 0.047uF/16V K,RoHS	DARFON,TDK,WALSIN,YAGEO,	7	PC	C113,C114,C115,C119, C120,C121,C152,	A
80	419302700510R	C SMD(0402) NPO 27PF/50V J RoHS	DARFON,MURATA, TDK,WALSIN,YAGEO,	2	PC	C130,C129,	A
90	419351054060R	C SMD(0603) X5R 1uF/16V K,RoHS	DARFON,MURATA, TAIYO,TDK,WALSIN,YAGEO,	1	PC	C148,	A



**Service Manual**

100	419302200510R	C SMD(0402) NPO 22PF/50V J,RoHS	DARFON,MURATA, TDK,WALSIN,YAGEO,	2	PC	C157,C158,	A
110	411020026210R	DIO BAV99 350mW 70V SOT-23(PHI RoHS	PHILIPS,	4	PC	D102,D103,D104,D105,	A
110	411020026090R	DIO BAV99 350mW 75V SOT-23(PEC RoHS	PANJIT,	0	PC		A
110	411020026440R	DIO LBAV99LT1G SOT23(LRC)RoHS	LRC,	0	PC		A
120	411090058090R	SCHTKY BAT54C 30V/0.2A SOT-23(PEC)	PANJIT,	2	PC	D106,D201,	A
120	411090058440R	SCHTKY LBAT54CLT1G SOT-23(LRC)	LRC,	0	PC		A
130	432002312144R	BEAD CORE SMD(0603)120Ω 300mA SB	CHILISIN,TAI-TECH,	1	PC	FB101,	A
140	432002360140R	BEAD CORE SMD(0603)60Ω 600mA,	CHILISIN,TAI-TECH,	2	PC	FB102,FB105,	A
150	410500068290R	XSTR AP2305GN P-CH SOT23(APEC) RoHS	APEC,	1	PC	Q101,	A
150	410500075270R	XSTR AO3415 P-CH,SOT23(AOS) RoHS	AOS,	0	PC		A
150	410060018380R	XSTR AM2321P-T1-PF P-CH SOT23	AP,	0	PC		A
160	410500045210R	XSTR PMBT3904 NPN 200MA,40V SOT23	PHILIPS,	2	PC	Q104,Q203,	A
160	410500045140R	XSTR MMBT3904LT1G NPN 200MA 40V	ON SEMI,	0	PC		A
160	410500045090R	XSTR MMBT3904 NPN SOT-23(PANJIT)RoHS	PANJIT,	0	PC		A
170	410500046210R	XSTR PMBT3906 PNP 200MA,40V SOT23	PHILIPS,	2	PC	Q107,Q108,	A
170	410500046090R	XSTR MMBT3906 PNP SOT-23(PANJIT)RoHS	PANJIT,	0	PC		A
170	410500046180R	XSTR MMBT3906LT1G PNP 200mA 40V	ON SEMI,	0	PC		A
180	414918010350R	RES SMD (0402) 10KΩ J,RT,RoHS	TA-I,UNIOHM,WALSIN,YAGEO,	18	PC	R108,R129,R150,R166, R169,R170,R171,R172, R173,R174,R176,R177, R180,R189,R190,R213, R211,R212,	A
190	414918000050R	RES SMD (0402) 0Ω J,RT,RoHS	TA-I,UNIOHM,WALSIN,YAGEO,	10	PC	R147,R148,R201,R202, R203,R204,R205,R206, R207,R208,	A
200	414918047250R	RES SMD (0402) 4.7KΩ J,RT,RoHS	TA-I,UNIOHM,WALSIN,YAGEO,	6	PC	R127,R128,R137,R138, R140,R217,	A
210	414916000050R	RES SMD (0603) 0Ω J,RT RoHS	TA-I,UNIOHM,WALSIN,YAGEO,	3	PC	RB101,RB102,RB103,	A
220	414918010450R	RES SMD (0402)100KΩ J,RT,RoHS	TA-I,UNIOHM,WALSIN,YAGEO,	1	PC	R175,	A
230	414918027350R	RES SMD (0402) 27KΩ J,RT,RoHS	TA-I,UNIOHM,WALSIN,YAGEO,	2	PC	R107,R109,	A
250	414918750910R	RES SMD (0402) 75Ω F,RT,RoHS	TA-I,UNIOHM,WALSIN,YAGEO,	9	PC	R117,R118,R119,R114, R115,R116,R122,R123, R124,	A
260	414918047150R	RES SMD (0402) 470Ω J,RT,RoHS	TA-I,UNIOHM,WALSIN,YAGEO,	1	PC	R159,	A
270	414918010250R	RES SMD (0402) 1KΩ J,RT,RoHS	TA-I,UNIOHM,WALSIN,YAGEO,	8	PC	R133,R134,R153,R154, R155,R160,R158,R218,	A
280	414918010150R	RES SMD (0402) 100Ω J,RT,RoHS	TA-I,UNIOHM,WALSIN,YAGEO,	7	PC	R131,R132,R142,R143, R209,R210,R157,	A
290	414918022250R	RES SMD (0402) 2.2KΩ J,RT,RoHS	TA-I,UNIOHM,WALSIN,YAGEO,	2	PC	R135,R136,	A
300	414918390010R	RES SMD (0402) 390Ω F,RT,RoHS	TA-I,UNIOHM,WALSIN,YAGEO,	1	PC	R144,	A
310	414916033150R	RES SMD (0603) 330Ω J,RT RoHS	TA-I,UNIOHM,WALSIN,YAGEO,	2	PC	R165,R168,	A
320	412000332130R	IC AP1117D33LA 3.3V (ANACHIP) TO-252-3L,	ANACHIP,	1	PC	U101,	A
320	412000241550R	IC AME1117CCCTZ 3.3V,TO-252(AM E)RoHS	AME,	0	PC		A
320	412000332020R	IC LD1117AL-3.3-A TO-252(UTC)RoHS	UTC,	0	PC		A
320	412000332830R	IC AS1117R-3.3.TR-LF,TO-252(A1 SEMI)RoHS	A1SEMI,	0	PC		A
320	412000332990H	IC EC50117KAG 3.3V TO-252(E-CMOS)	E-CMOS,	0	PC		A



**Service Manual**

330	412000330020R	IC LD1117AL-1.8V-A SOT223(UTC) RoHS	UTC,	1	PC	U102,	A
330	412000599990H	IC EC50117BBG 1.8V SOT223(E-CMOS)	E-CMOS,	0	PC		A
330	412000330830R	IC AS1117L-1.8/TR-LF,SOT223(A1 SEMI)RoHS	A1SEMI,	0	PC		A
330	412000330070R	IC AZ1117H-1.8 SOT223(AAC)RoHS	BCD,	0	PC		A
340	412000435481R	IC AT24C02BN-SH-T 2K SOIC8(ATMEL)RoHS	ATMEL,	2	PC	U103,U204,	A
340	412000769830R	IC AS24C02ID-18/TR-LF SOP8(A1SEMI)	A1SEMI,	0	PC		A
340	412000480280R	IC M24C02-RMN6TP SO8(ST)RoHS	ST,	0	PC		A
340	412000480990R	IC CAT24C02WI-TE13 SOIC-8(CATALYST)	CATALYST,	0	PC		A
350	412000722062R	IC TSUMU58EDJ-LF-2 PQFP128(MSTAR)	MSTAR,	1	PC	U105,	A
360	412000224482R	IC AT24C16BN-SH-T 16K(ATMEL) SOIC 8	ATMEL,	1	PC	U106,	A
360	412000224280R	IC M24C16-WMN6TP SO8 16K (ST) ROHS	ST,	0	PC		A
360	412000481990R	IC CAT24C16WI-TE13 SOIC-8(CATALYST)	CATALYST,	0	PC		A
370	412000494190R	IC SST25LF020A-33-4C-SAE SOIC8(SST)	SST,	1	PC	U108,	A
370	412000721560R	IC W25X20AVSNIG SOIC8(WINBOND)	WINBOND,	0	PC		A
370	412000494310R	IC PM25LV020-100SCE SOIC8(PMC)RoHS	PMC,	0	PC		A
380	411130962950R	ZENER 6.2V MMSZ5234B SOD-123(PANJIT)	PANJIT,	9	PC	ZD102,ZD103,ZD104, ZD105,ZD106,ZD107, ZD202,ZD205,ZD206,	A
380	411121462950R	ZENER 6.2V BZT52-C6V2 SOD-123(WILLAS)	WILLAS,	0	PC		A
380	411131562950R	ZENER 6.2V BZT52C6V2-7-F SOD-123	DIODES,	0	PC		A
400	492411300100R	PCB,I/F ,2/OSP /FR4 /16,LE20Q5,RoHs	EXPRESS,SHENG HUA,	1	PC		A
410	414918100210R	RES SMD (0402) 10KΩ F,RT,RoHS	TA-I,UNIOHM,WALSIN,YAGEO,	2	PC	R151,R152,	A
420	506140005700R	LABEL,BARCODE,BLANK,33x7mm, ROHS	HENGMINGDA,JIAYINMEI,KAIDA,	1	PC		A
430	511130002200R	SOLDER PASTE,TYPE3,2045,Sn96.5%Ag3%	TOMAS,	0.5	G		A
430	511130002201R	SOLDER PASTE,TYPE4,2038,Sn96.5%Ag3%	TOMAS,	0	G		A

**3. Power keypad BOM**

ITEM	P/N	Description	Supplier	Usage	Un	Lo
	792821500000R	PCBA,POWER KEY/BD.,LE20Q5 ROHS				
10	430639040050R	WFR 4P 1.25MM V/A SMD W/LOCK ROHS	JOWLE,	1	PC	CA
20	411070133500R	LED SMD LTW-C195UCKS-5A(liteon) Rohs	LITEON,	1	PC	LE
20	411070142500R	LED SMD W/Y HTL-19-22UWUOC/TR8(HongTong)	HONGTONG,	0	PC	
20	411070141500R	LED SMD W/Y KPTB-1612FX385-SZ(Kingbrig	KINGBRIGHT,	0	PC	
30	492411500000R	PCB,K/PWR,2/ENIG/FR4 /08,LE20Q5,RoHs	EXPRESS,SHENG HUA,	1	PC	
40	411131562950R	ZENER 6.2V BZT52C6V2-7-F SOD-123(DIODES)	DIODES,	1	PC	ZC
40	411121462950R	ZENER 6.2V BZT52-C6V2 SOD-123(WILLAS)ROH	WILLAS,	0	PC	
40	411130962950R	ZENER 6.2V MMSZ5234B SOD-123(PANJIT)RoH	PANJIT,	0	PC	



**Service Manual**

50	430602680300R	SW,METAL DOME 180gf 1P ROHS	HUA-JIE,唯佳	1	PC
----	---------------	-----------------------------	------------	---	----

**4. OSD keypad BOM**

ITEM	P/N	Description	Supplier	Usage	Un
	792821500010R	PCBA,OSD KEY/BD.,LE20Q5 ROHS			
10	430639040060R	WFR 4P 1.25MM R/A SMD W/LOCK ROHS	JOWLE,		1 PC
20	414916820110R	RES SMD (0603) 8.2KΩ F,RT RoHS	TA-I,WALSIN,YAGEO,		2 PC
30	414916470110R	RES SMD (0603) 4.7KΩ F,RT RoHS	TA-I,WALSIN,YAGEO,		2 PC
50	430602980110R	SW TACT 160gf 1P,R/A SMD 1BT00 2-0120L,R	ALPS,HUA-JIE,ZJGHJ,		4 PC
60	511130002200R	SOLDER PASTE,Sn96.5-Ag3.0-Cu0.5 ROHS	TOMAS,	0.06	G
60	511130002201R	SOLDER PASTE,Sn96.5%Ag3.0%Cu0.5%	TOMAS,		0 G
60	511130002202R	SOLDER PASTE,Sn95.5%Ag3.9%Cu0.6%	TAMURA,		0 G
70	411131562950R	ZENER 6.2V BZT52C6V2-7-F SOD-123(DIODES)	DIODES,		6 PC
70	411121462950R	ZENER 6.2V BZT52-C6V2 SOD-123(WILLAS)ROH	WILLAS,		0 PC
70	411130962950R	ZENER 6.2V MMSZ5234B SOD-123(PANJIT)RoH	PANJIT,		0 PC
80	492411500010R	PCB,K/OSD,2/OSP /FR4 /16,LE20Q5,RoHs	EXPRESS,SHENGHUA		

**5.Assembly BOM**

ITEM	P/N	Description	Supplier	Usage	Un	Rev
	8201Q581D010R	ST2010/U854M/LE20Q5-817/SAM/DAO				
10	453070800150R	PWR CORD 10A/125V BLK 6FT UL/CSA SVT 3Cx	Foxconn,I-shen		1 PC	C
20	453010100320R	CABLE D-SUB 15P MALE 6FT BLACK/BLUE AB 8	Foxconn,JVE HOTRON,廣宇		1 PC	B
30	714074083001R	ASSY,FINAL(B+S)W/O SPK,LE20Q5-817(ST2010			1 PC	A
40	713100015900R	ASSY, PACKAGE, PACK, DAO,LE20Q5			1 PC	A
ITEM	P/N	Description	Supplier	Usage	Un	Rev
	713100015900R	ASSY, PACKAGE, PACK, DAO,LE20Q5				A
10	506140005800R	LABEL BARCODE LE1963	高綺,鍵升,		1 PC	B
20	506250001800R	LABEL,AGENCY, LE20Q5	高綺,鍵升,		1 PC	A
30	506431008700R	FILM,SCREEN,PROTECTION,PRINTED,LP20P9	柏興,鴻旺,		1 PC	A
40	506380001400R	TAPE 3M-897 12x45000mm	久威,	0.0033	ROL	A
50	506280011301R	POSTER,QUICK SETUP,WEST, LE20Q5	裕同,鴻達,		1 PC	A
60	703000011500R	KIT,ACCESSORY, DOC, DAO, LE20Q5	裕同,鴻達,		1 PC	A
70	506120304900R	BAG, L330xW260xT0.05MM(PRINTED), LENOVO	柏興,鴻旺,		1 PC	A





**Service Manual**

80	506120011300R	BAG,PLASTIC,L620xW550mm(PRINTED), LE20P9	柏興,鴻旺,	1	PC	A
90	506020003600R	CARTON,DELL(WWW), LE20Q5	佳藝,美盈森,	1	PC	A
100	506060018000R	Cushion EPS-TOP ,LE20Q5	東揚,	1	PC	A
110	506060018001R	Cushion EPS-BOTTON ,LE20Q5	東揚,	1	PC	A
120	506340004700R	LABEL BLANK 101X50mm DELL EMEA CARTON	高綺,鍵升,	1	PC	A
130	506380002622R	TAPE, WRAPPING TYPE PRINTED(DELL), BLACK	佳普森,	0.0015	ROL	A
140	713010008102R	ASSY PACK,40HQ,LE20Q5		1	PC	A
140	713010008101R	ASSY PACK,40STD,LE20Q5		0	PC	A
140	713010008100R	ASSY PACK,20STD,LE20Q5		0	PC	A
140	713010008103R	ASSY PACK,AIR/JAPAN CARGO (20/40STD),LE2		0	PC	A
150	506060018002R	Cushion EPS-MIDDLE,SMALLER,LE 20Q5	東揚,	1	PC	A
ITEM	P/N	Description	Supplier	Usage	Un	Rev
	714074083001R	ASSY,FINAL(B+S)W/O SPK,LE20Q5-817(ST2010				A
10	509212103500R	SCREW,F,CROSS,T.T-2*3,BLK	高億,	2	PC	A
20	509146610101R	SCREW,P,M4X8,BLACK	鴻益進,	3	PC	A
30	714020021500R	STAND-ASSY,LE20Q5	富鴻齊,	1	PC	A
40	714030027600R	FRONT-BEZEL-ASSY,LE20Q5	PCM,	1	PC	A
50	714077440700R	BACK-COVER-ASSY,LE20Q5	PCM,	1	PC	A
60	714084083001R	ASSY,PANEL,W/O SPK,LE20Q5-817(ST2010)		1	PC	A
70	509116610510R	SCREW,P,CROSS,M4*10,BLACK-NL(NYLOK)	鴻益進,	2	PC	A
80	501110202004R	REAR-LOGO,LE20Q5	MMP,	1	PC	A
ITEM	P/N	Description	Supplier	Usage	Un	Rev
	713010008100R	ASSY PACK,20STD,LE20Q5				A
10	506432004700R	SLIP SHEET,L1188xW1146xH75mm, LE20M9	SUNSTREAM,	0	PC	A
20	506037012500R	CARDBOARD,COVER,L1170xW1140xH100xT3mm,LE	佳藝,美盈森,	0	PC	A
30	506039005410R	CORNER PAPER 800x50x50xT3mm LE1718	佳藝,金惠,	0	PC	A
40	506039006100R	CORNER PAPER 1250x50x50xT3mm LE963 ROH	佳藝,	0	PC	A
50	506431000300R	FILM,PE 500mmx900M ROHS	三輝,柏興,	0	ROL	A
60	506038008100R	CARDBOARD,PAPER,L1100*1150*T3mm	佳藝,	0	PC	A
70	506380002612R	TAPE,WRAPPING TYPE,50Mx82mm	佳普森,	0	ROL	A
ITEM	P/N	Description	Supplier	Usage	Un	Rev
	713010008101R	ASSY PACK,40STD,LE20Q5				A
10	506432004700R	SLIP SHEET,L1188xW1146xH75mm, LE20M9	SUNSTREAM,	0	PC	A
20	506037012500R	CARDBOARD,COVER,L1170xW1140xH100xT3mm,LE	佳藝,美盈森,	0	PC	A
30	506039005410R	CORNER PAPER 800x50x50xT3mm LE1718	佳藝,金惠,	0	PC	A



**Service Manual**

40	506039006100R	CORNER PAPER 1250x50x50xT3mm LE963 ROH	佳藝,	0	PC	A
50	506431000300R	FILM,PE 500mmx900M ROHS	三輝,柏興,	0	ROL	A
60	506038008100R	CARDBOARD,PAPER,L1100*1150*T3mm	佳藝,	0	PC	A
70	506120400100R	BAG AIR DUNNAGE 2000x1000mmLE1X03 ROHS	SISUN,	0	PC	A
80	506380002612R	TAPE,WRAPPING TYPE,50Mx82mm	佳普森,	0	ROL	A
ITEM	P/N	Description	Supplier	Usage	Un	Rev
	713010008102R	ASSY PACK,40HQ,LE20Q5				A
10	506432004700R	SLIP SHEET,L1188xW1146xH75mm, LE20M9	SUNSTREAM,	0.0208	PC	A
20	506037012500R	CARDBOARD,COVER,L1170xW1140xH100xT3mm,LE	佳藝,美盈森,	0.0417	PC	A
30	506039006100R	CORNER PAPER 1250x50x50xT3mm LE963 ROH	佳藝,	0.0833	PC	A
40	506431000300R	FILM,PE 500mmx900M ROHS	三輝,柏興,	0.0013	ROL	A
50	506038008100R	CARDBOARD,PAPER,L1100*1150*T3mm	佳藝,	0.0208	PC	A
60	506120400100R	BAG AIR DUNNAGE 2000x1000mmLE1X03 ROHS	SISUN,	0.0005	PC	A
70	506380002612R	TAPE,WRAPPING TYPE,50Mx82mm	佳普森,	0.0003	ROL	A
ITEM	P/N	Description	Supplier	Usage	Un	Rev
	713010008103R	ASSY PACK,AIR/JAPAN CARGO (20/40STD),LE2				A
10	506150014600R	PALLET L1170xW1140xH120mm LE20Q5	觀瀾實習工廠,	0	PC	A
20	506037012500R	CARDBOARD,COVER,L1170xW1140xH100xT3mm,LE	佳藝,美盈森,	0	PC	A
30	506039005410R	CORNER PAPER 800x50x50xT3mm LE1718	佳藝,金惠,	0	PC	A
40	506039001400R	CORNER PAPER 200x50x50mm ROHS	佳藝,金惠,	0	PC	A
50	506431000300R	FILM,PE 500mmx900M ROHS	三輝,柏興,	0	ROL	A
60	506380002612R	TAPE,WRAPPING TYPE,50Mx82mm	佳普森,	0	ROL	A
ITEM	P/N	Description	Supplier	Usage	Un	Rev
	714030027600R	FRONT-BEZEL-ASSY,LE20Q5				A
10	501010227000R	FRONT-BEZEL,LE20Q5	MMP,	1	PC	A
20	751020200100R	SUB,POWER BUTTON,,LASER ETCH,LE20Q5	PCM,	1	PC	A
30	501110500301R	LOGO PALTE DELL Apollo 4		1	PC	A
ITEM	P/N	Description	Supplier	Usage	Un	Rev
	714077440700R	BACK-COVER-ASSY,LE20Q5				A
10	501020233300R	BACK COVER,LE20Q5	MMP,	1	PC	A
20	501280200400R	VENT-COVER,LE20Q5	MMP,	1	PC	A
30	501010227001R	MID-FRAME-L,LE20Q5	MMP,	1	PC	A
40	501010227002R	MID-FRAME-R,LE20Q5	MMP,	1	PC	A
50	509012306400R	SCREW,I,CROSS,Φ5.5,T3*6,Zn-Cc	鴻益進,	4	PC	A



**Service Manual**

60	502210100300R	KENSINGTON LOCK LP1703 ROHS	MMP,	1	PC	A
ITEM	P/N	Description	Supplier	Usage	Un	Rev
	714084083001R	ASSY,PANEL,W/O SPK,LE20Q5-817(ST2010)				A
10	631102200530RD	LCP 20.0"LTM200KT03-C02(A)(SAMSUNG)ROHS		1	PC	A
20	701000016500R	CHASSIS-ASSY,LE20Q5	MMP,	1	PC	A
30	506380001730R	TAPE ACE 85x20mm LE1913	久威,	1	PC	A
40	509146306202R	SCREW,P,CROSS,W/WAS(7.8),M3*6,Zn-Cc,ROHS	高億,	4	PC	A
50	509446309100R	SCREW,B,CROSS,W/W-SPR,M3*9,Zn,ROHS	HUAMAO,	1	PC	A
60	509016304200R	SCREW,I,CROSS,M3*4,Zn-CcROHS	高億,鴻益進,	4	PC	A
70	509016306200R	SCREW,I,CROSS,M3*6,Zn-Cc	高億,	2	PC	A
80	509000001000R	BOLT,#4-40x12.5,Ni ROHS	高億,	2	PC	A
90	505040212400R	MYLAR FOR CHASSIS,LE20Q5	富准,	1	PC	A
100	505040212401R	MYLAR FOR PANEL,LE20Q5	富准,	1	PC	A
110	501030215101R	OSD BUTTON,LE20Q5	MMP,	1	PC	A
120	792821300800R	PCBA,I/F BOARD,W/O SPK,LE20Q5-817 ROHS		1	PC	AA
130	792821400800R	PCBA,P/I BOARD,W/O SPK,LE20Q5-817 ROHS		1	PC	AA
140	792821500000R	PCBA,POWER KEY/BD.,LE20Q5 ROHS		1	PC	AA
150	792821500010R	PCBA,FUNCTION KEY/BD.,LE20Q5 ROHS		1	PC	AA
160	430303002460R	HRN LVDS FFC 30P 180mm LOCK	FOXCONN, P-TWO,	1	PC	A
170	430300802970R	HRN ASSY 2x4P to 4P 500mm390mm UL1571#28	FOXCONN, JVE,RISE,	1	PC	A
ITEM	P/N	Description	Supplier	Usage	Un	Rev
	701000016500R	CHASSIS-ASSY,LE20Q5				A
10	502090104300R	CHASSIS,LE20Q5		1	PC	A
20	502040400600R	SHIELD EMI LP2207		3	PC	A
ITEM	P/N	Description	Supplier	Usage	Un	Rev
	751020200100R	SUB,POWER BUTTON,,LASER ETCH,LE20Q5				A
10	501030215100R	POWER BUTTON,LE20Q5	MMP,	1	PC	A

## **Attachment 2- Schematic**

### **1. Interface board schematic**

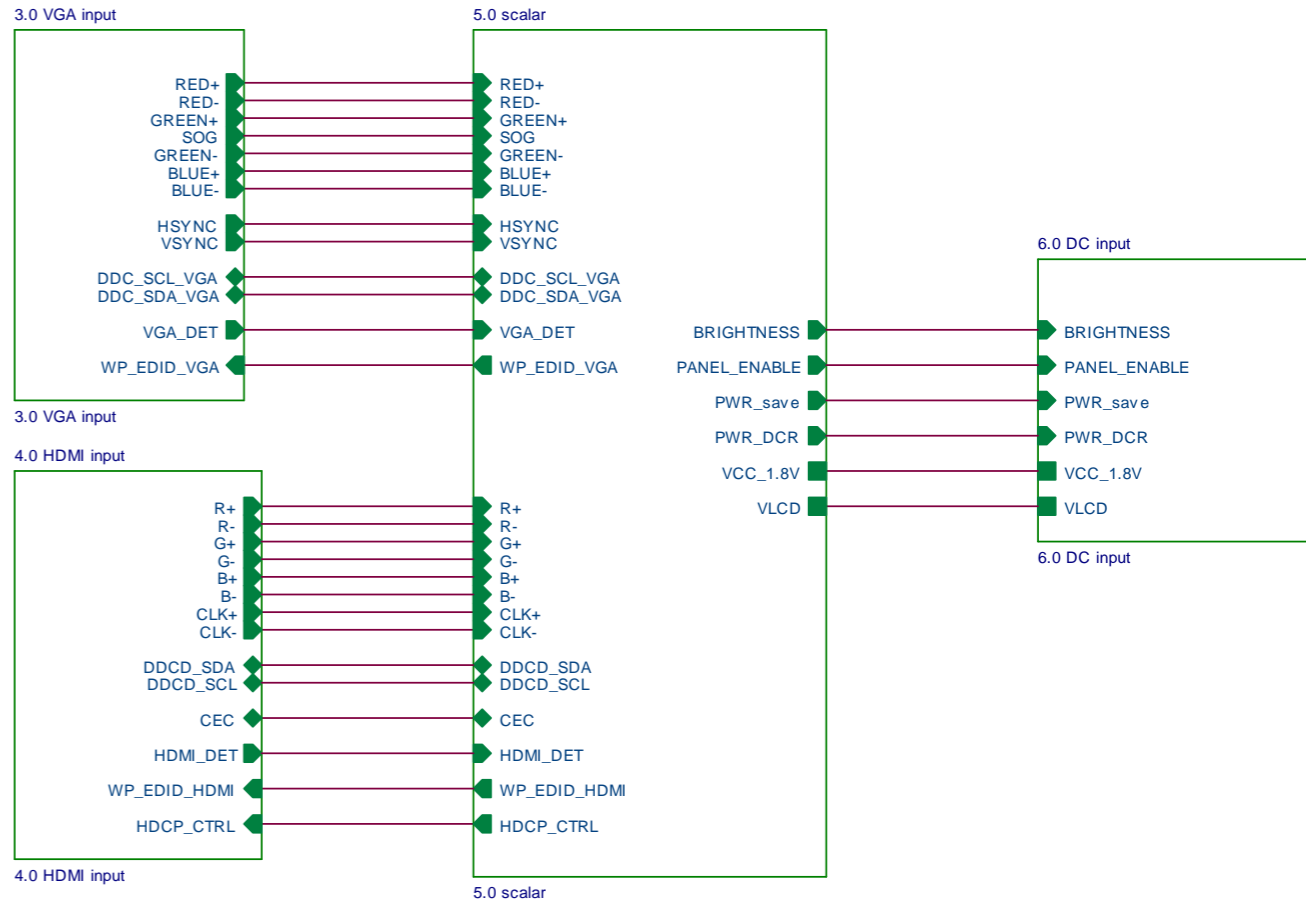


**Service Manual**

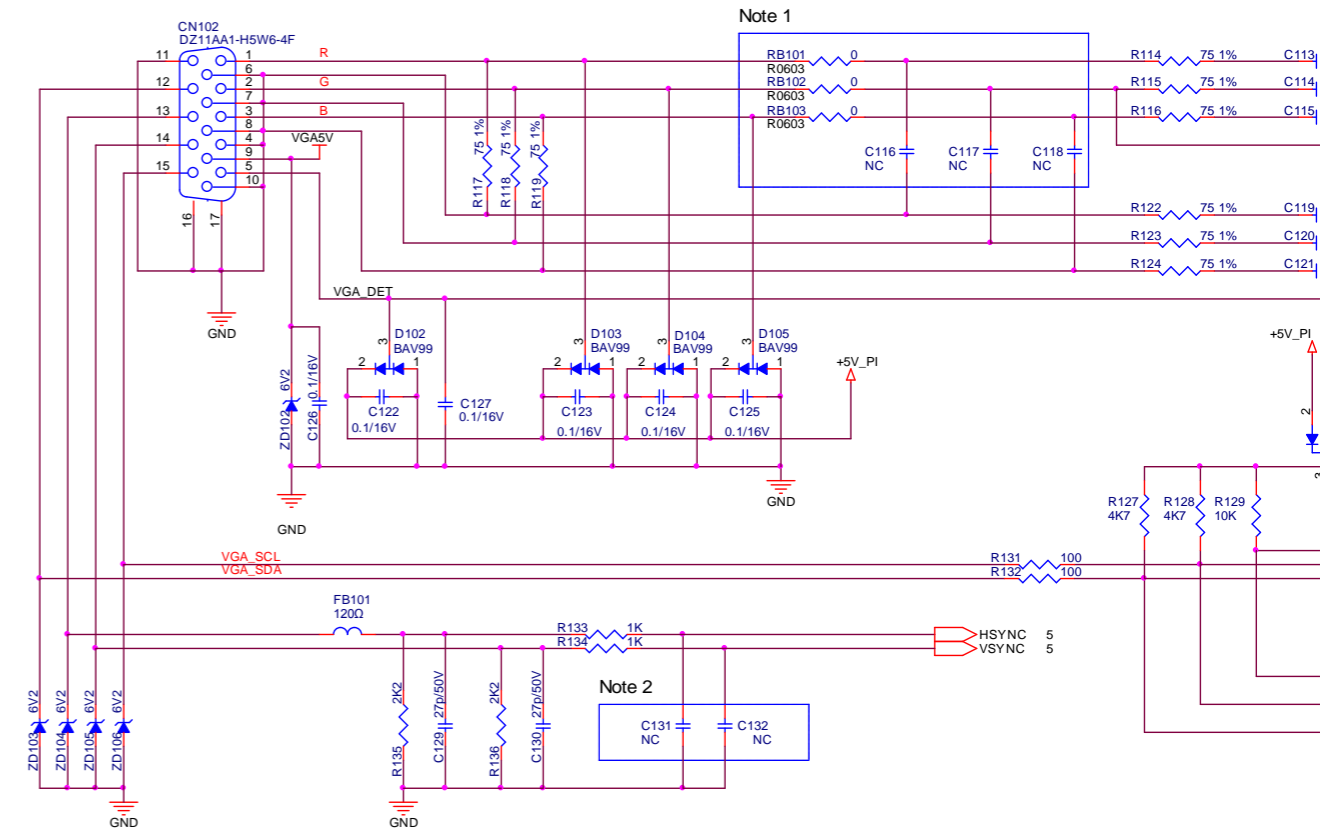
ST2010	
Title	page
1.0 Top level	1
2.0 contents	2
3.0 VGA input	3
4.0 HDMI input	4
5.0 Scalar	5
6.0 DC input	6

History
Rev01(movk up ): Initial
Rev02(proto1): Delete R105 R156 Delete CCFL_ON_OFF signal Delete R102 R103 R106 Q103 Delete FB204~207
Rev03(proto3): DeleteD202 D203 DeleteC202 C203

Title	
<b>contents</b>	
Size	Document Number
A4	<Doc>
Date:	Monday, February 09, 2009
Sheet	



Title		<b>Top level</b>
Size	A4	Document Number <Doc>
Date:	Monday, February 09, 2009	Sheet

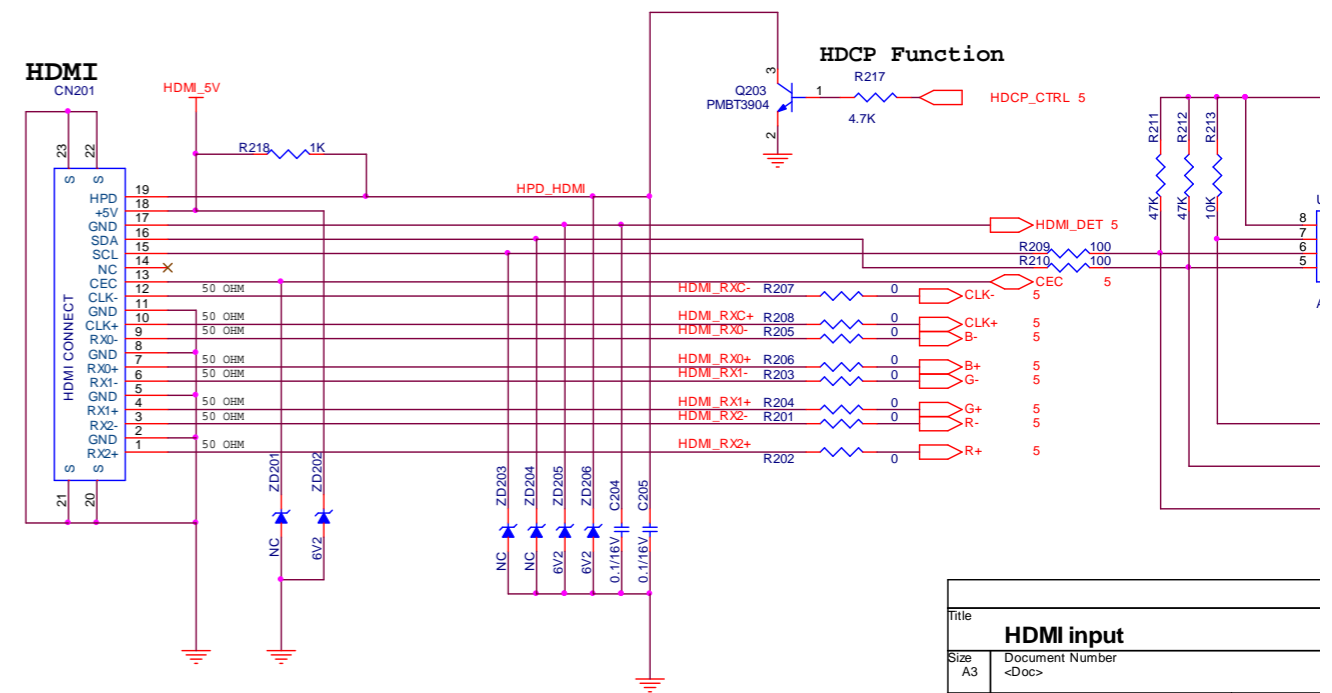


Note 1

Note 2

- Note:
1. R0603 package for Bead. C116,C117,C118 10pF are reserved for EMI or performance issue.
  2. C131,C132 27P are reserved for tuning performance issue.

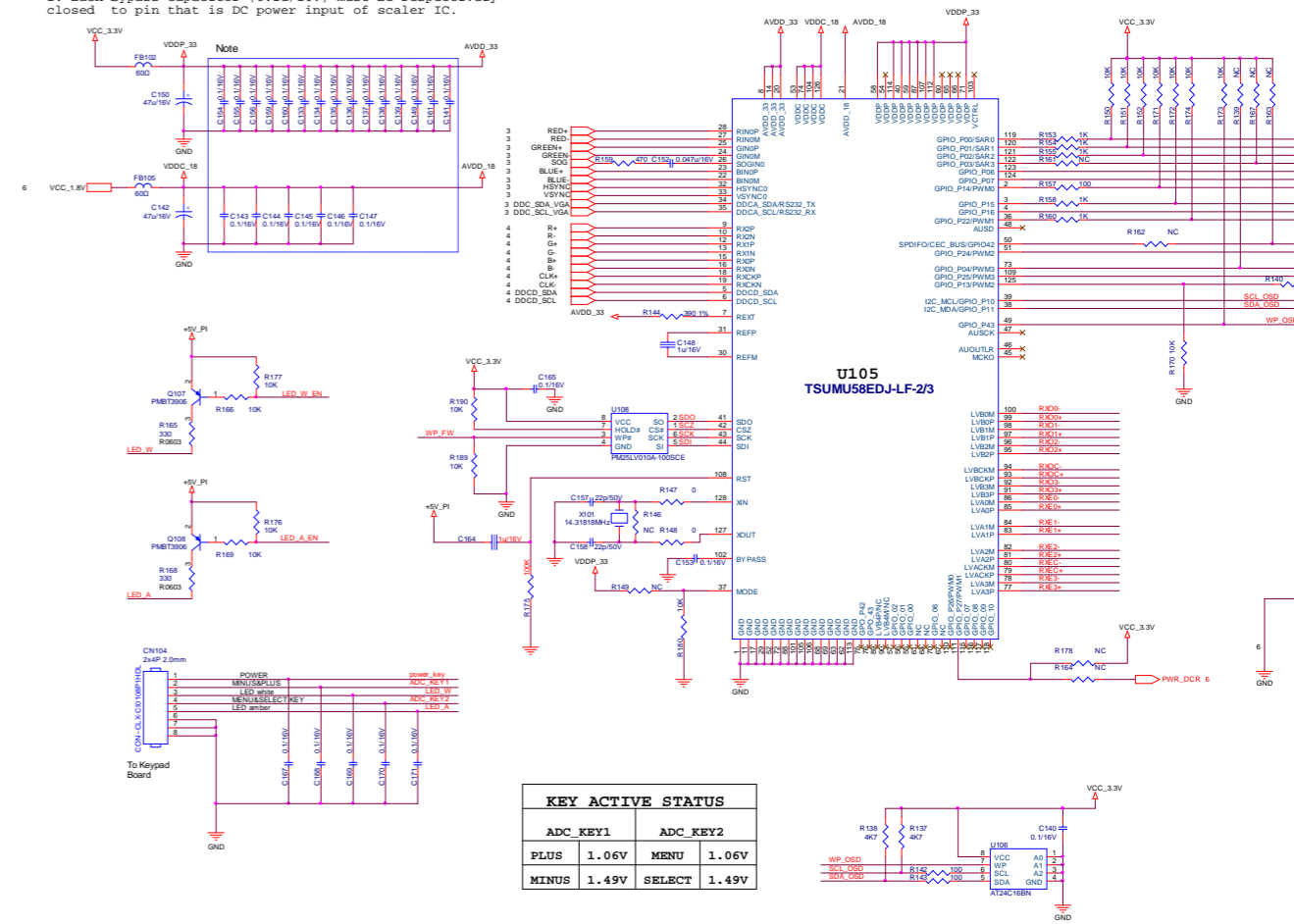
Title		<b>VGA</b>
Size	A4	Document Number <Doc>
Date:	Monday, February 09, 2009	



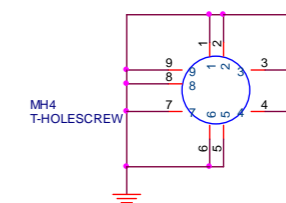
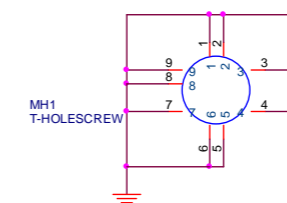
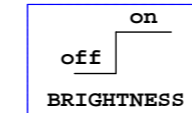
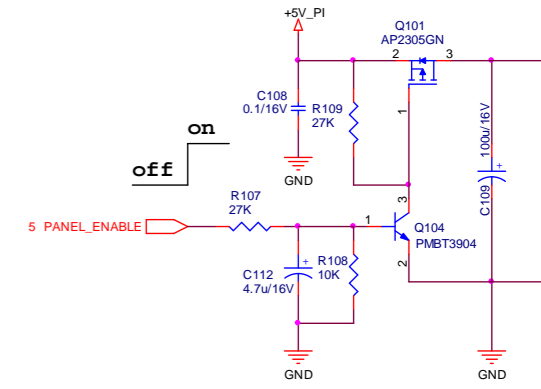
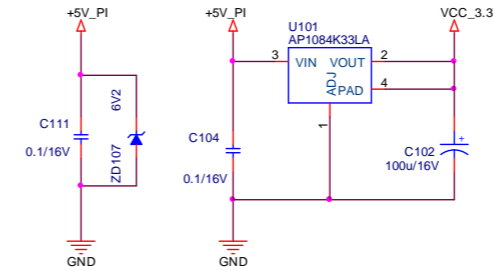
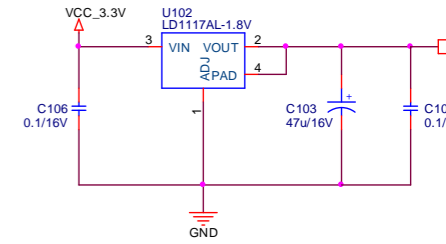
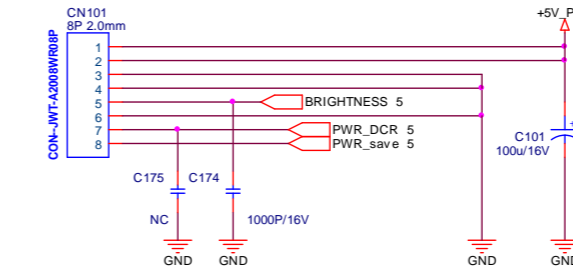
HDCP Function

Title		<b>HDMI input</b>
Size	A3	Document Number <Doc>
Date:	Monday, February 09, 2009	Sheet 4

Note:  
1. Each bypass capacitor (0.1u/16V) must be respectively closed to pin that is DC power input of scaler IC.





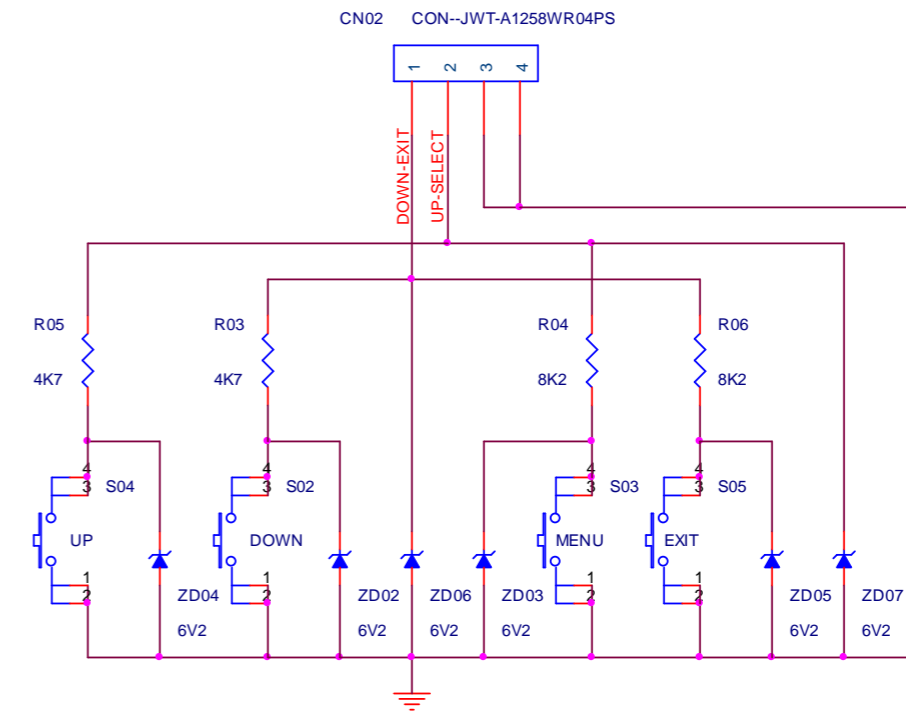


Title		<b>DC input</b>
Size	Document Number	<Doc>
A4		
Date:		Monday, February 09, 2009



E:\ST2010\proto3\  
del st2010 pvt.pdf

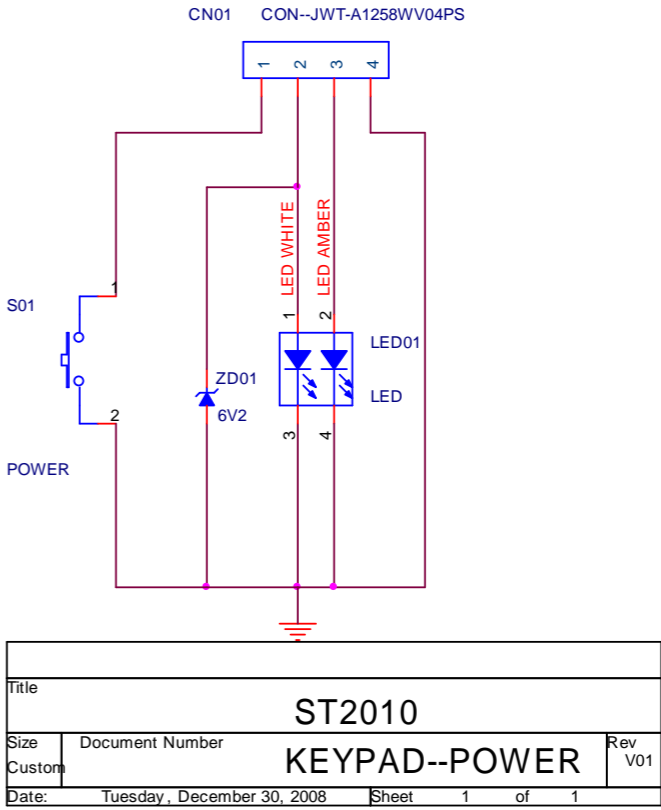
## 2. OSD keypad schematic



KEY ACTIVE STATUS			
ADC_KEY1		ADC_KEY2	
DOWN	1.06V	UP	1.06V
EXIT	1.49V	MENU(SELECT)	1.49V

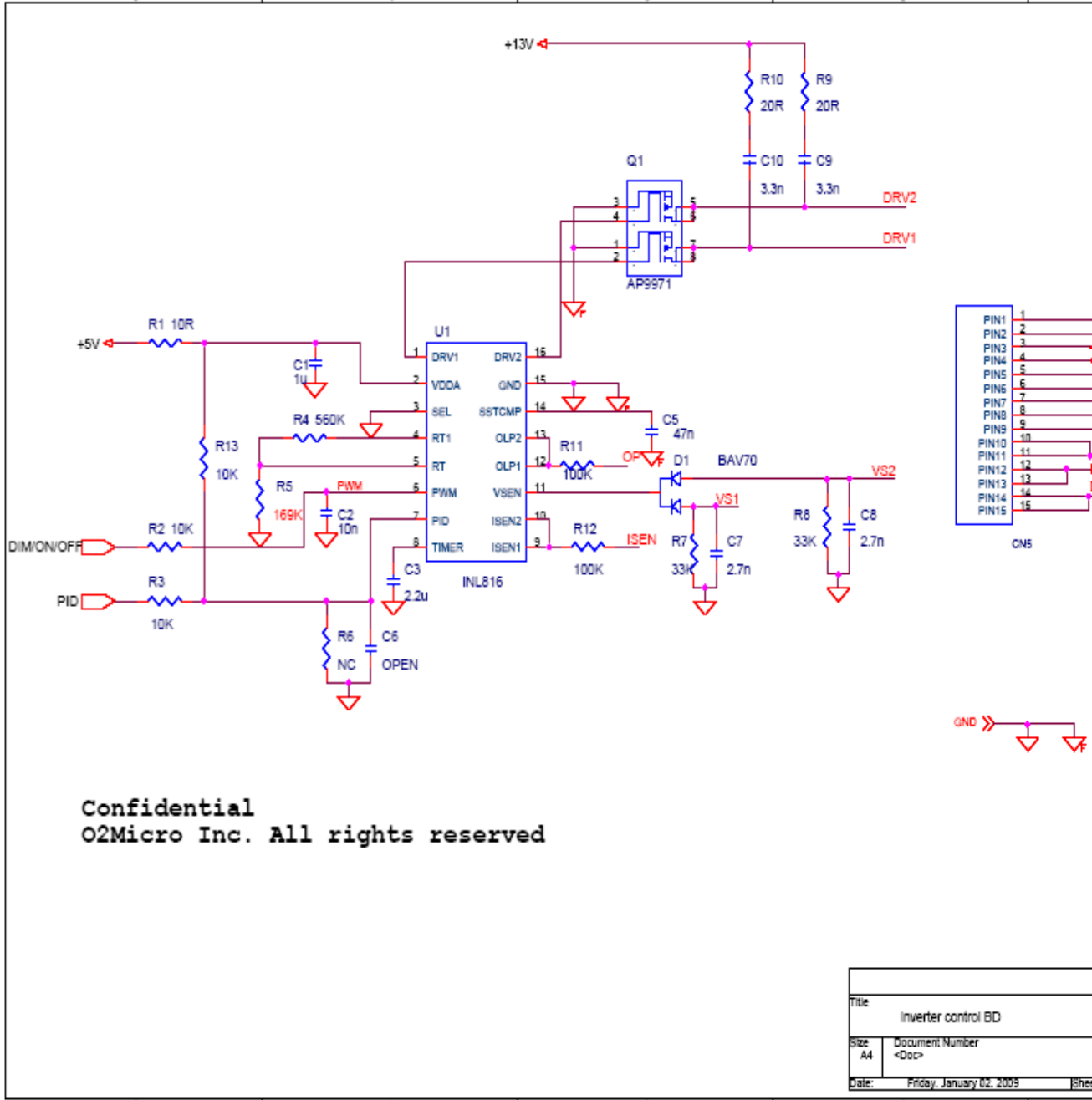
Title		ST2010	
Size	Document Number	Function keypad	
A			
Date:	Tuesday, December 30, 2008	Sheet	1 of

### 3. Power keypad schematic

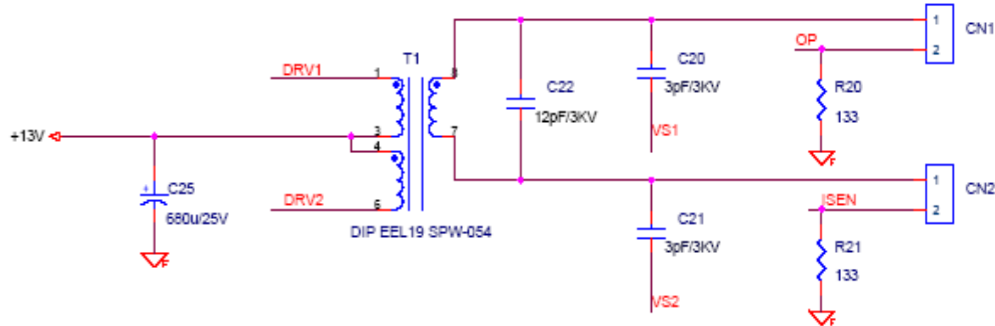


power board schematic

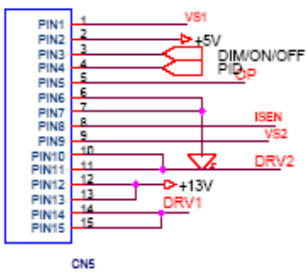
1



D



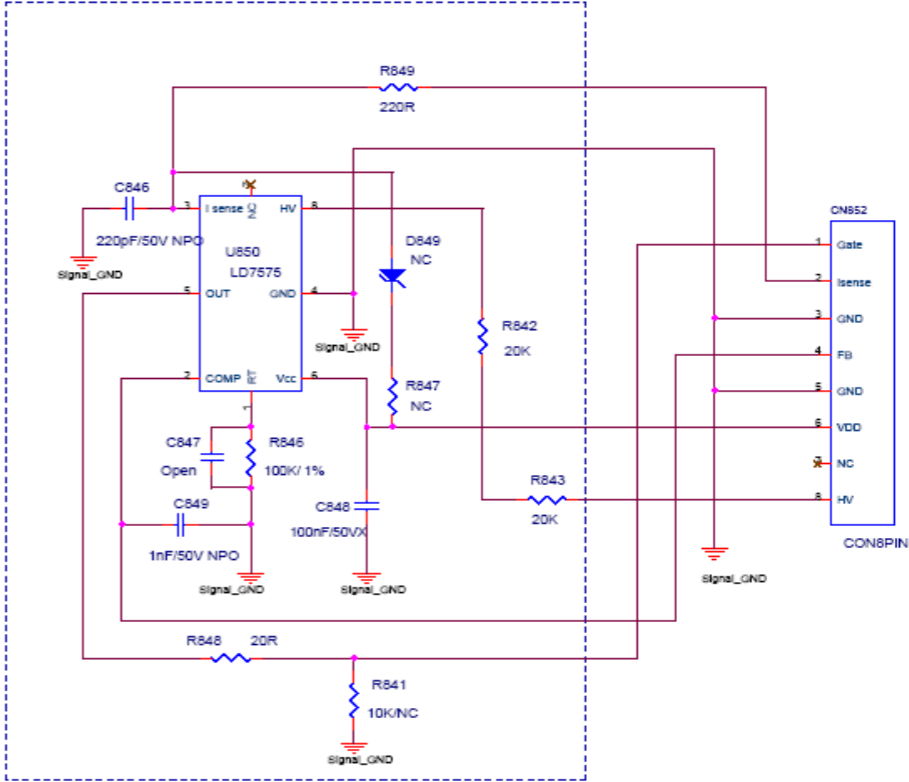
C



B

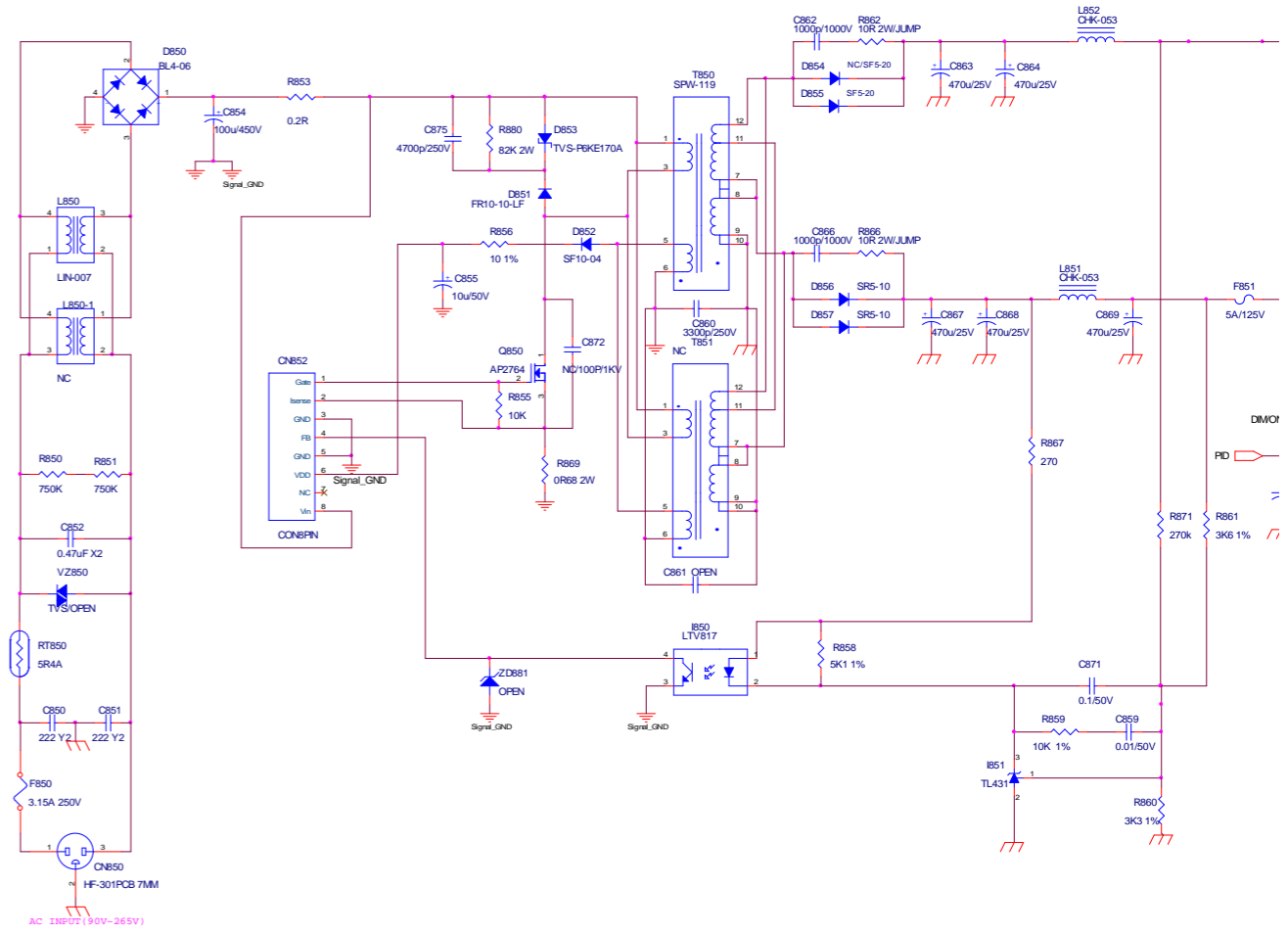
A

Title		Inverter DC to AC
Size	A4	Document Number <Doc>
Date:	Friday, January 02, 2005	



A

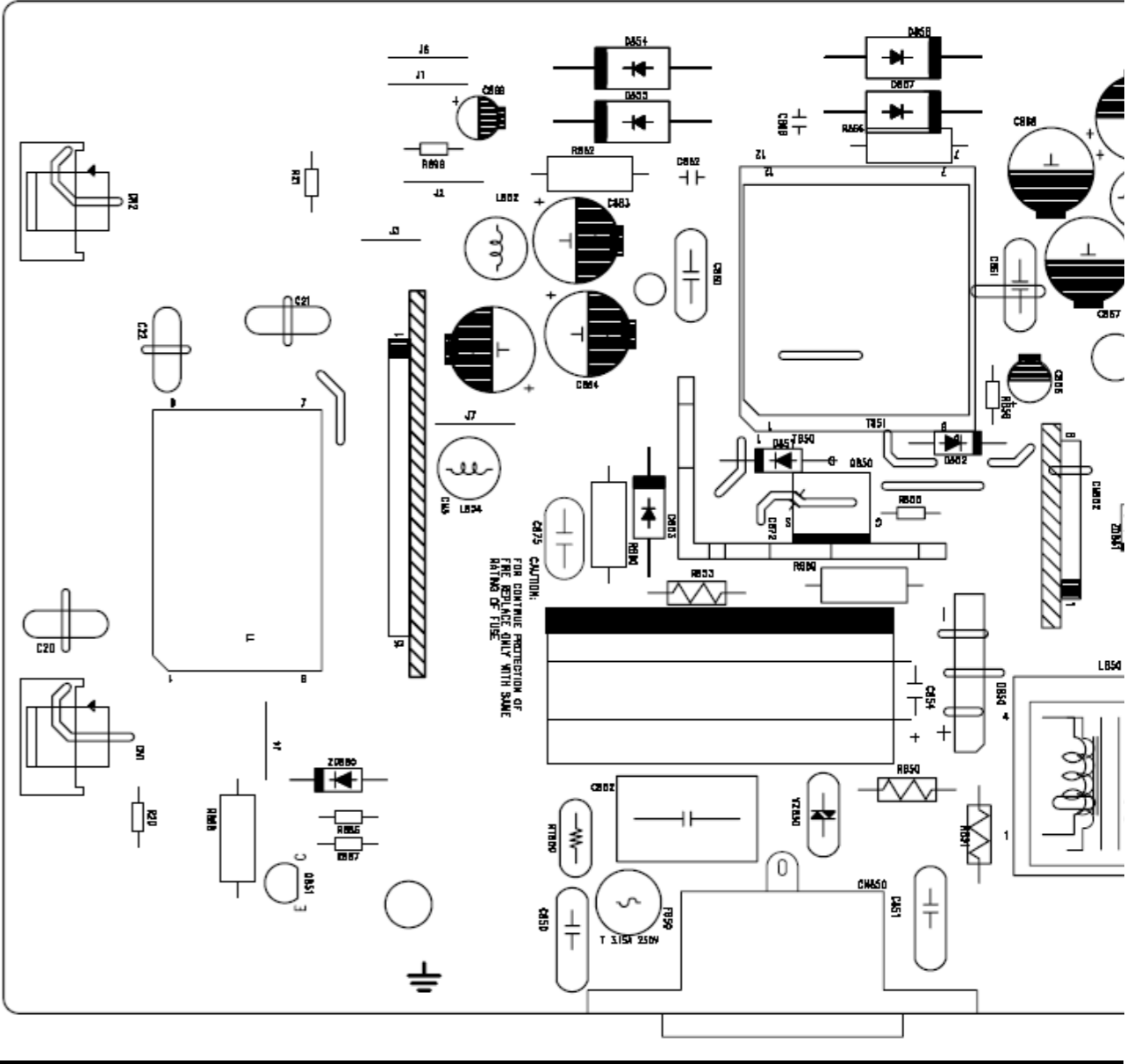
Title	Power control BD LD7575
Size	A4
Document Number	<Doc>
Date	Fri, January 02, 2009



File	Power AC to
Size	Document Numbe
Date	Friday, January 20,

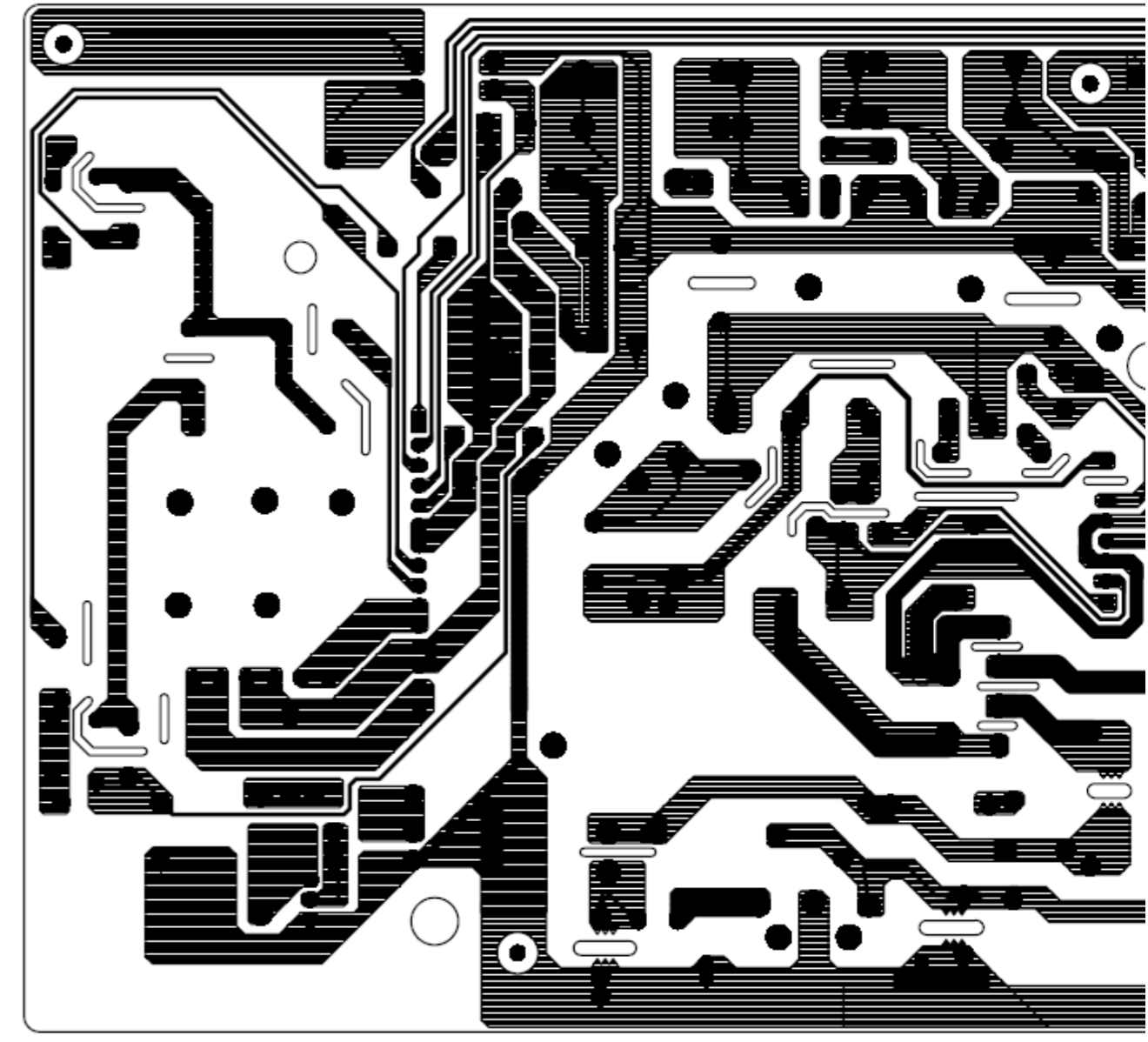
### Attachment 3- PCB Layout

Power/inverter board:  
Top Layer

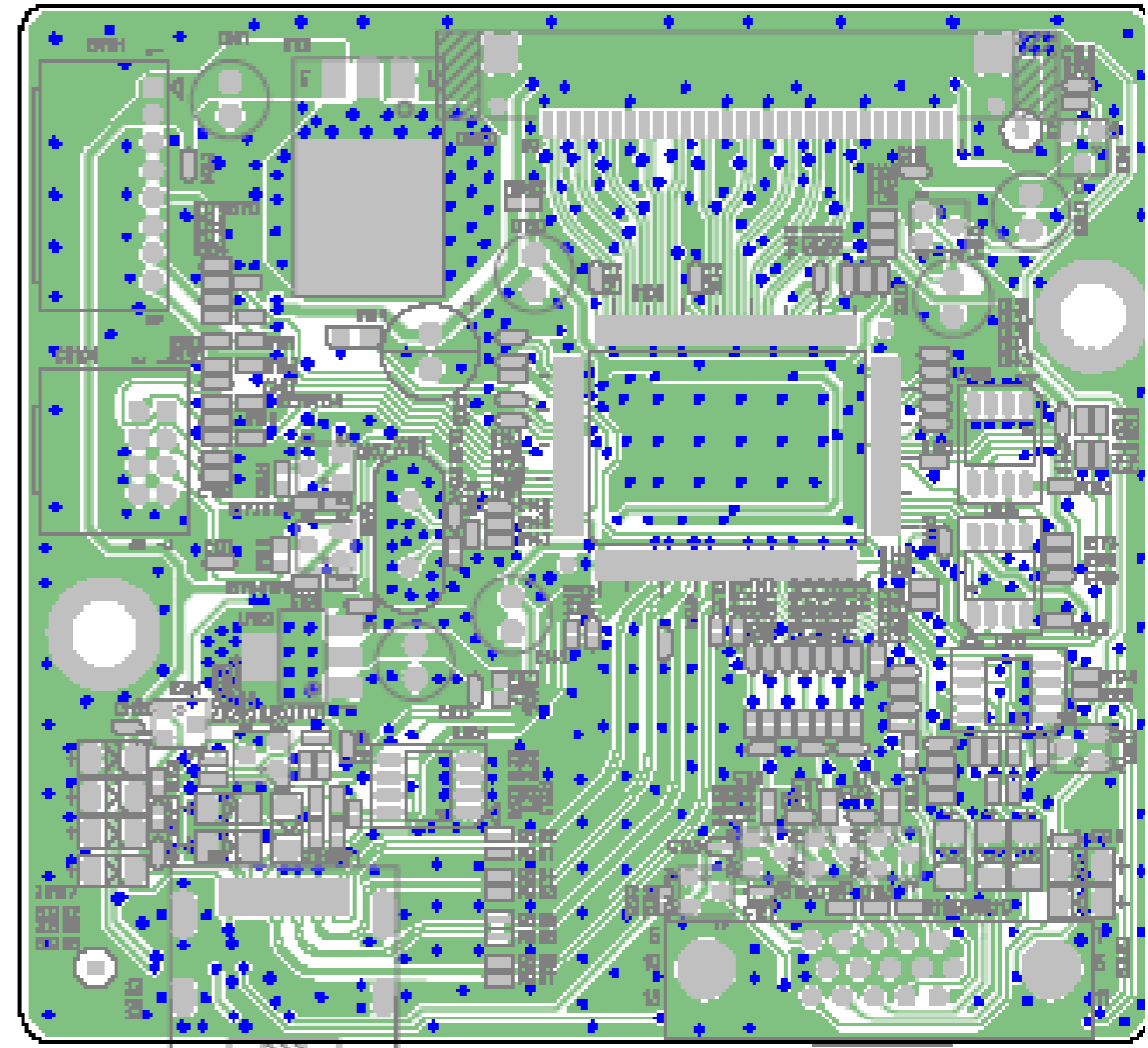




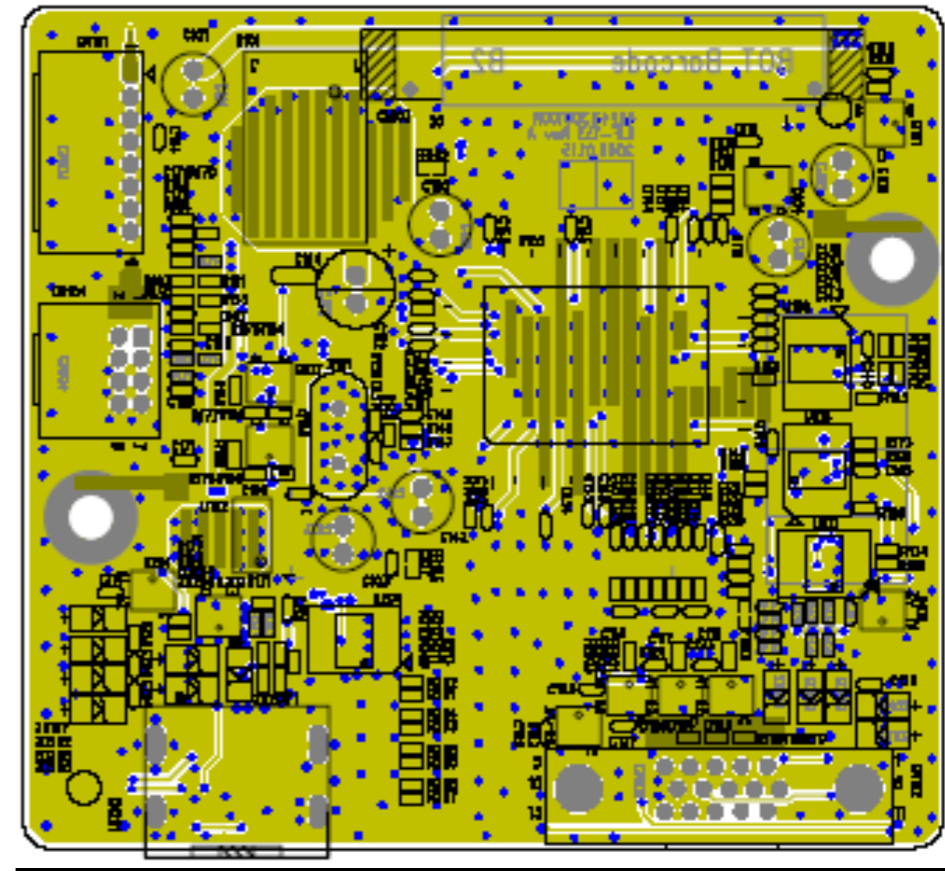
Bottom Layer



**I/F board:**  
**Top Layer**



**Bottom Layer**

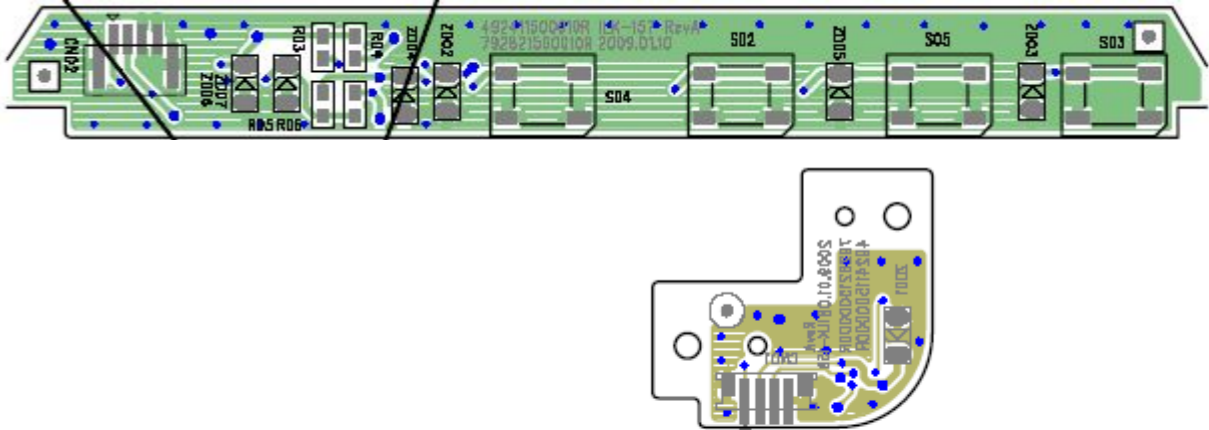


LAYER	<b>SOLDER MASK BOTTOM</b>			
PCB NO :	492411300100R	REV :	A	DESIGNER: QZ HAN
FILE NAME :	ILIF-133	DATE :	2009.01.15	

Keypad:



Innolux	LAYER	<b>L2 GND</b>		
	PCB NO	492411500010R	REV	A
	FILE NO	ILK-157	REMARK	2009/01/10



	LAYER	DRILL DRAWING			
Innolux	PCB NO	492411500000R	REV	A	DESIGNER:Yu
	FILE NO	ILK-158	REMARK		2009.01.08

