

PCI/USB ADSL CHIPSET: ST70138 + MTC20174 FOR ULTRA LOW COST ADSL MODEM

DATA BRIEF

1 DESCRIPTION

The Unicorn II chipset is designed to simplify the development of low-cost ADSL CPE modems for Windows, Mac and Linux based environments and enables manufacturers to achieve a very competitive production cost. Due to its controller-less architecture and particularly the advantage that it does not require an external SDRAM in its E-BOM, the total cost of the external components needed in the modem is the best in its class. With a low component count of less than 140 external components and small form factor packages, the Unicorn II easily fits on a standard 2 layer single sided PCB with small dimensions which contributes significantly to further lowering overall system costs. Together with its low power consumption, high-speed performance up to 8 Mbps and customizable complete software driver packages, the Unicorn II is the ideal choice for USB and PCI based ADSL modems.

The Unicorn II chipset consists of the digital ST70138 chip and the MTC20174 analog front end.

The ST70138 is supplied in two packages, TQFP144 and LPGA80. The ST70138T packaged in TQ144 is a pin-to-pin compatible version of the ST70137 enabling manufacturers to benefit directly from the cost and performance advantages that the ST70138 brings.

The TQ144 flavor brings out both the USB and PCI interfaces. Supplied in a compact USB-only LPGA80 package, the ST70138B brings additional cost advantages to new designs.

The MTC20174 Analog Front End (AFE) with integrated line driver is designed for DMT based ADSL CPE modems compliant with ANSI T1.413 issue 2, ITU G.992.1 (G.dmt) and ITU G.992.2 (G.lite), for Annex A, B and C.

Figure 1. Chipset Architecture Overview

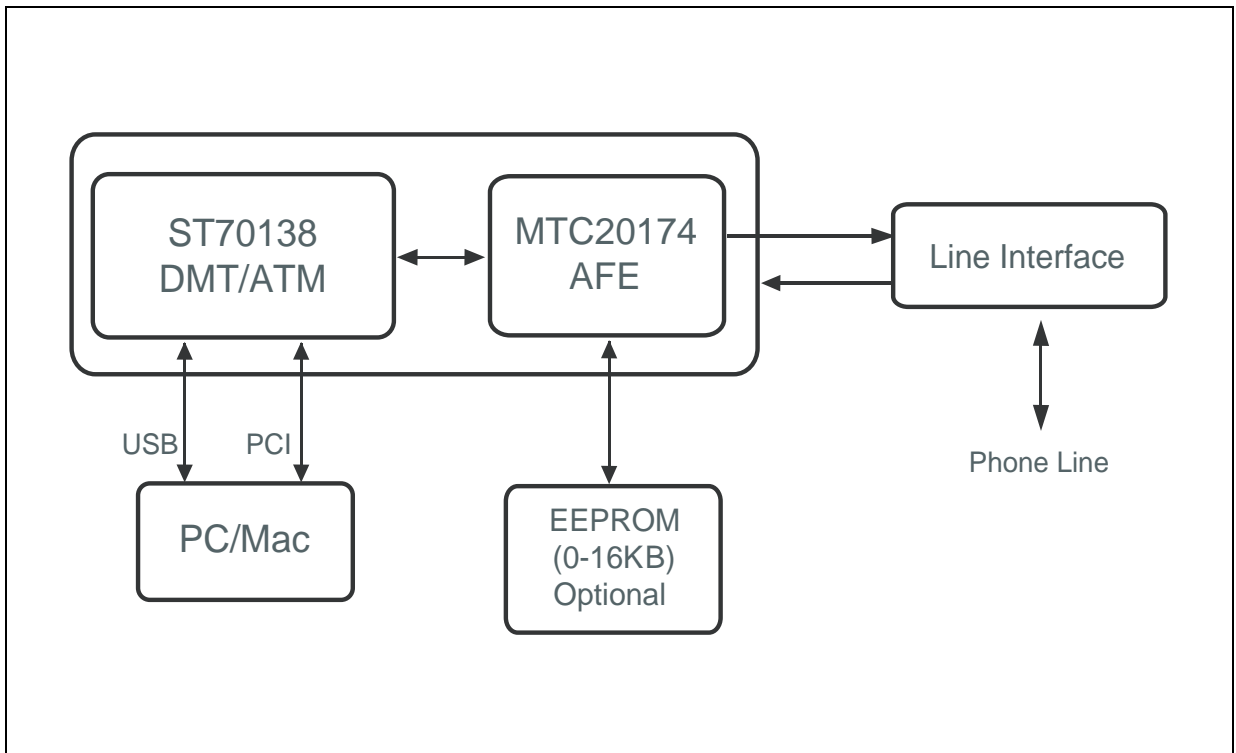

2 STANDARDS COMPLIANCE AND INTEROPERABILITY

www.DataSheet4U.com

Eleven years of experience have enabled ST to develop a chipset that offers full compatibility with all current full-rate and G.lite ADSL standards, USB standards including plug-and-play support. The Unicorn II chipset has a comprehensive driver suite that supports Windows, Mac and Linux. The Unicorn is fully interoperable with all major DSLAMs and is compliant to TR-048 (DSLforum) and ETSI 101 388 performance requirements.

2.1 Protocols Supported

- RFC 2684 bridged (LLC/SNAP and VCMUX)
- replacing RFC 1483
- RFC 2684 routed (LLC/SNAP and VCMUX)
- replacing RFC 1483
- RFC 2364 PPP over ATM
(LLC and VCMUX)
- RFC 2516 PPP over Ethernet
(LLC and VCMUX)
- RFC 2225 Classical IP over ATM

2.2 ATM and ATM adaptation support

- VPI range: 0 - 255
- VCI range: 32 - 65535.
- UNI 3.0, 3.1, 4.0 signaling
- TR37 (auto-configuration)
- UBR, CBR (with customizable parameters)
- AAL0, AAL5

3 SOFTWARE SUITE

Unicorn shipping package includes a complete set of field proven software drivers and tools for Windows, Mac and Linux, including PC software for modem control and communications protocols. The software drivers are fully configurable and include diagnostic tools which are specifically developed to minimize operator helpdesk interference.

3.1 Software interface

- NDIS WAN or NDIS5-ATM PCI driver and USB driver
- MAC / Linux OS: Open Transport driver

3.2 OS support

- Win98, Win98SE, WinME, Win2K, WinXP
- MAC OS 8.6 till 10.3.x
- Up to Linux kernel 2.6.x

3.3 Hardware interfaces

- USB connector or PCI interface
- RJ11 connector

3.4 Maximum supported speed

- 8Mbps downstream
- 1Mbps upstream



UNICORN II™ USB CONTROLLERLESS ADSL DMT TRANCEIVER

DATA BRIEF

4 HARDWARE FEATURES

- SUPPORT DIGITAL SIGNAL PROCESSING REQUIREMENTS FOR ONE ADSL CPE CHANNEL (ITU-R)
- COMPLIANT WITH ITU 992.1 (ADSL FULL RATE) ANNEX A (ADSL OVER POTS), ANNEX B (ADSL OVER ISDN), ITU 922.2 (G.LITE) AND ANSI T1.413.
- ENHANCED FTP TRANSFER CAPABILITIES
- DIRECT INTERFACE TO USB (USB RELEASE 1.1 SPECIFICATION)
- DIRECT INTERFACE TO EXTERNAL 8/16bit SERIAL MEMORY TO SUPPORT USB USER'S CONFIGURATION.
- DIRECT ANALOG FRONT END INTERFACE FOR MTC20174
- CLOCK & RESET INTERFACE
- 1.8V AND 3.3V POWER SUPPLY
- TTL LOGIC LEVELS COMPATIBLE
- POWER MANAGEMENT CAPABILITIES
- LOW POWER CONSUMPTION : MAX 0.45W
- TQFP144 (ORDER CODE ST70138T - BACKWARD COMPATIBLE WITH PREVIOUS ST70137)
- LFBGA80 (ORDER CODE ST70138B)

5 DESCRIPTION

Unicorn II is an evolution of the field-proven and mass deployed Unicorn modem that dramatically lowers the overall system cost when designing and producing a USB ADSL modem. The Unicorn II chipset is designed using cost effective CMOS technology, further integrating external components which leads to even lower E-BOM costs, reduced component count and lower PCB complexity; All of this while increasing overall performance. Its proven controller-less and SDRAM-less architecture is highly competitive and well suited in today's cost focused modem market.

The Unicorn II chipset is designed to simplify the development of low-cost ADSL CPE modems for Windows, Mac and Linux based environments and enables manufacturers to achieve a very competitive production cost. Due to its controller-less architecture and particularly the advantage that it does not require an external SDRAM in its E-BOM, the total cost of the external components needed

Figure 2. Packages**Table 1. Order Codes**

Part Number	Package
ST70138T	TQFP144
ST70138B	LFBGA80

in the modem is the best in its class. With a low component count of less than 140 external components and small form factor packages, the Unicorn II easily fits on a standard 2 layer single sided PCB with small dimensions which contributes significantly to further lowering overall system costs. Together with its low power consumption, high-speed performance up to 8 Mbps and customizable complete software driver packages, the Unicorn II is the ideal choice for USB based ADSL modems.

The ST70138T/B is the ADSL DMT transceiver chip of the UNICORN2™ Chipset.

ST70138T is intended to be used as a pin-to-pin replacement part of the ST70137 device in order to get advantage from its better cost-structure and its enhanced FTP transfer capabilities. ST70138T is packaged in a TQ144 package. Full backward compatibility with already existing USB PCB designs is assured.

ST70138B, packaged in LFBGA80 is intended for new PCB designs, which will benefit from extensive E-BOM reduction in the reference design, mass production friendly EEPROM programming, enhanced FTP throughput and overall lower system cost structures.

Eleven years of experience have enabled ST to develop a chipset that offers full compatibility with all current full-rate and G.lite ADSL standards, USB standards including plug-and-play support. The Unicorn II chipset has a comprehensive driver suite that supports Windows operating systems from 98 to XP, Mac operating systems 8 to X and Linux. The Unicorn is fully interoperable with all major DSLAMs and is compliant to TR-048 (DSLforum) and ETSI 101 388 performance requirements.

ADSL ANALOG FRONT END WITH INTEGRATED LINE DRIVER FOR CPE APPLICATIONS

DATA BRIEF

6 FEATURES

- Fully Integrated AFE and Line Driver for ADSL
- Overall 12 bit resolution, 1.1MHz signal bandwidth
- 8.8 MS/s ADC
- 8.8 MS/s DAC
- Differential analog I/O
- Accurate continuous-time channel filtering
- 5th & 4th order tunable continuous-time receive and transmit filters respectively
- Support for multiple ADSL standards:
 - ANSI T1.413 Issue 2
 - ITU G.992.1 (G.dmt)
 - Annex A
 - Annex B (ADSL over ISDN)
 - Annex C (ADSL over ISDN SBM/DBM/ G.dmt)
 - ITU G.992.2 (G.lite)
- Highest performance:
 - Operation up to 18 kft (26 AWG)
 - More than 8 Mbps downstream and 832 Kbps upstream up to 8 kft (26 AWG)
 - More than 3 Mbps downstream and 760 kbps upstream up to 12 kft (26 AWG)
- 100 pin TQFP package allows high-density board design
- Power dissipation of 900mW at 25°C, typical

7 APPLICATIONS

The MTC20174 is an ADSL Analog Front-End (AFE) with integrated Line-Driver for ATU-R applications offering Annex A, B and C.

8 GENERAL DESCRIPTION

The MTC20174 Analog Front End (AFE) with integrated line driver is designed for DMT based ADSL CPE modems compliant with ANSI T1.413 issue 2, ITU G.992.1 (G.dmt) and ITU G.992.2 (G.lite), for Annex A, B and C.

Figure 3. Package



Table 2. Order Codes

Part Number	Package	Temperature
MTC20174-TQ-C1	TQFP100	0 to 70°C
MTC20174-TQ-C1TR	Tape & Reel	0 to 70°C

It is intended to be used with the MTC20166 DMT modem and ATM framer as part of the MTK20170 chipset, but may also be used to support other ADSL signal processors. It includes the following parts:

- A 12-bit 8.8Msamples/s DAC
- A 13-bit 8.8Msamples/s ADC
- Tunable low-pass and high-pass filters
- Low-noise PGAs
- A TX Pre-Amplifier
- A TX Line-Driver
- A fully integrated DCXO
- A PLL-based frequency doubler
- A filter tuning circuit
- A dying gasp circuit
- A digital module for control, test and interface

The following figure provides a graphical representation of the MTC20174 functional blocks with an additional separation in RX and TX path.

The analog and digital part have separated 3.3V power supplies. In addition some part of the analog section of the MTC20174 has a power supply of 5V.

The typical total power consumption of the MTC20174 is 900mW for 12dBm of line power (full operation) at 25°C.

The package is a 100 pin TQFP.

Table 3. Revision History

www.DataSheet4U.com

Date	Revision	Description of Changes
September 2004	1	First Issue

Information furnished is believed to be accurate and reliable. However, STMicroelectronics assumes no responsibility for the consequences of use of such information nor for any infringement of patents or other rights of third parties which may result from its use. No license is granted by implication or otherwise under any patent or patent rights of STMicroelectronics. Specifications mentioned in this publication are subject to change without notice. This publication supersedes and replaces all information previously supplied. STMicroelectronics products are not authorized for use as critical components in life support devices or systems without express written approval of STMicroelectronics.

The ST logo is a registered trademark of STMicroelectronics.
All other names are the property of their respective owners

© 2004 STMicroelectronics - All rights reserved

STMicroelectronics group of companies

Australia - Belgium - Brazil - Canada - China - Czech Republic - Finland - France - Germany - Hong Kong - India - Israel - Italy - Japan -
Malaysia - Malta - Morocco - Singapore - Spain - Sweden - Switzerland - United Kingdom - United States of America

www.st.com