



# MODEL: ST2151B01-1

Ver. 2.3

Date: 17.Aug.2016

<b>Customer's Approval</b>		<b>CSOT</b>	
Signature	Date	Approved By Product Director	Date
		Name: Albert Hu	
		Signature:	
		Reviewed By PM Manager	Date
		Name: Aaron Tu	
		Signature:	
		Reviewed By Project Leader	Date
		Name: Nianmao Wang	
		Signature:	
		Reviewed By PM	Date
		Name: Xiaoju Wu	
		Signature:	

# Contents

<b>1. General Description</b>	4
<b>1.1 Product Features</b>	4
<b>1.2 Overview</b>	4
<b>1.3 General Information</b>	4
<b>2. Absolute Maximum Ratings</b>	5
<b>2.1 Absolute Maximum Ratings (<math>T_A = 25 \pm 2 \text{ }^\circ\text{C}</math>)</b>	5
<b>2.2 Environment Requirement (Based on CSOT's BLU)</b>	5
<b>2.3 Absolute Ratings of Environment (Open Cell)</b>	5
<b>3. Electrical Specifications</b>	6
<b>3.1 Open Cell Power Consumption (<math>T_A = 25 \pm 2 \text{ }^\circ\text{C}</math>)</b>	6
<b>3.2 LVDS Characteristics</b>	7
<b>3.3 Temperature Specifications</b>	8
<b>4. Input Terminal Pin Assignment</b>	9
<b>4.1 Interface Pin Assignment</b>	9
<b>4.2 Block Diagram of Interface</b>	11
<b>4.3 LVDS Interface</b>	12
<b>4.3.1 VESA Format</b>	12
<b>4.4 V-com Adjustment</b>	12
<b>5. Interface Timing</b>	14
<b>5.1 Timing Table (DE Only Mode)</b>	14
<b>5.2 Power On/Off Sequence</b>	17
<b>6. Optical Characteristics</b>	18
<b>6.1 Measurement Conditions</b>	18
<b>6.2 Optical Specifications</b>	19
<b>7. Mechanical Characteristics</b>	23
<b>7.1 Mechanical Specification</b>	23
<b>7.2 Packing Specifications and Method</b>	24
<b>8. Definition of Labels</b>	26
<b>8.1 Open Cell Label</b>	26
<b>8.2 Carton Label</b>	26
<b>8.3 Pallet Label</b>	27
<b>9. Precautions</b>	28
<b>9.1 Assembly and Handling Precautions</b>	28
<b>9.2 Safety Precautions</b>	28

## Revision History

Version	Date	Page	Section	Description	Revision by
Ver. 0.1	20.Aug.2015	26	All	Tentative Specification was First Issued	Bin Sun
Ver. 1.1	25.Sep.2015	27	All	Preliminary specification was first issued	Bin Sun
Ver. 1.2	16.Nov.2015	28	1.3	Update 1.3 Weight	Bin Sun
Ver. 2.1	27.Jan.2016	28	All	Update 5.1 Timing Table	Bin Sun
Ver. 2.2	28.Jan.2016	24	7.2	Update Packing Specifications and Method	Bin Sun
Ver. 2.3	2.Aug.2016	26	All	Update Timing Table	Bin Sun

CSO  
Confidential

## 1. General Description

### 1.1 Product Features

- FHD Resolution (1920 \* 1080)
- Very High Contrast Ratio: 4000:1
- Fast Response Time
- Ultra Wide Viewing Angle: 178°(H)/178°(V) (CR≥10)
- DE (Data Enable)Mode
- LVDS (Low Voltage Differential Signaling) Interface

### 1.2 Overview

ST2151B01-1 is a diagonal 21.5" color active matrix LCD open cell with 1ch-LVDS interface. This open cell is a transmissive type display operating in the normally black mode. It supports 1920 \* 1080 FHD resolution and can display up to 16.7M colors (8bit). Each pixel is divided into Red, Green and Blue sub-pixels which are arranged in vertical stripe.

This open cell dedicates for LCD TV & Monitor products and provides excellent performance which includes high brightness, ultra wide viewing angle, high color saturation and high color depth. CSOT open cell comply with RoHS for identification.

### 1.3 General Information

Item	Specification	Unit	Note
Active Area	476.64 (H) * 268.11 (V)	mm	
Cell Size	487.54 (H) * 279.684 (V) * 1.335 (D)	mm	
Weight	0.42	Kg	Typ.
Driving Scheme	a-Si TFT Active Matrix	-	
Number of Pixels	1920 * 1080	pixel	
Pixel Pitch (Sub Pixel)	0.08275*0.24825	mm	
Pixel Arrangement	RGB Vertical Stripe	-	
Display Colors	16.7 M	color	8bit
Display Mode	Transmissive Mode, Normally Black	-	
Glass Thickness (Array/CF)	0.5/0.5	mm	
Color Chromaticity	R = (0.642, 0.343 ) G = (0.314, 0.610 ) B = (0.149, 0.054) W = (0.275, 0.298)		Typical value measured at CSOT's BLU
Contrast Ratio	4000:1(Typ.)		
Cell Transmittance	4.1(Typ.)	%	
View Angle (CR≥10)	+89/-89 (H), +89/-89 (V) (Typ.)		
Surface Treatment	Anti-glare, Haze 2%, Hard Coating (3H)		

## 2. Absolute Maximum Ratings

### 2.1 Absolute Maximum Ratings ( $T_A = 25 \pm 2 \text{ }^\circ\text{C}$ )

The followings are maximum values which, if exceeded, may cause damage to the unit.

Item	Symbol	Value		Unit
		Min.	Max.	
Power Supply Voltage	$V_{CC}$	-0.3	5.5	V
Input Signal Voltage	$V_{IN}$	-0.3	3.6	V

### 2.2 Environment Requirement (Based on CSOT's BLU)

(1) Temperature and relative humidity range are shown as below.

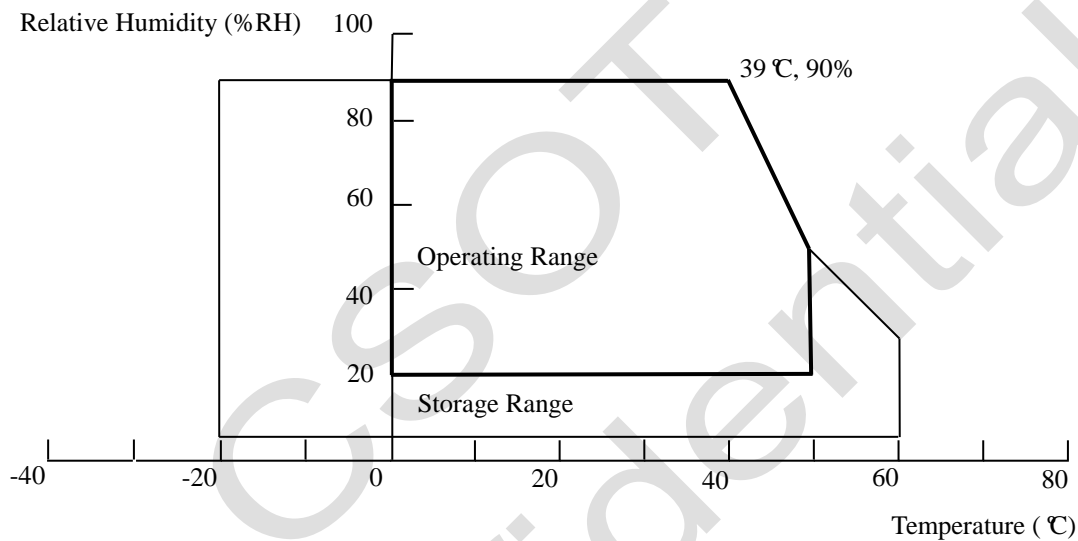

Fig. 2.1 Operating and storage environment

- (a) 90%RH maximum ( $T_A \leq 39 \text{ }^\circ\text{C}$ ).
- (b) Wet-bulb temperature should be 39 °C maximum ( $T_A > 39 \text{ }^\circ\text{C}$ ).
- (c) No condensation.

(2) The storage temperature is between  $-20 \text{ }^\circ\text{C}$  to  $60 \text{ }^\circ\text{C}$ , and the operating ambient temperature is between  $0 \text{ }^\circ\text{C}$  to  $50 \text{ }^\circ\text{C}$

The maximum operating temperature is based on the test condition that the surface temperature of display area is less than or equal to  $65 \text{ }^\circ\text{C}$  with LCD module in a temperature controlled chamber alone. Thermal management should be considered in final product design to prevent the surface temperature of display area from being over  $65 \text{ }^\circ\text{C}$ . The range of operating temperature may degrade in case of improper thermal management in the end product design.

(3) The rating of environment is based on LCD module. Leave LCD cell alone, this environment condition can't be guaranteed.

Except LCD cell, the customer has to consider the ability of other parts of LCD module and LCD module process.

### 2.3 Absolute Ratings of Environment (Open Cell)

When storing open cell as spares for a long time, please follow the precaution instructions:

- (1) Do not store the module in high temperature and high humidity for a long time. It is highly recommended to store the module with temperature from  $20 \text{ }^\circ\text{C}$  to  $30 \text{ }^\circ\text{C}$  in normal humidity ( $50 \pm 10\%RH$ ) with shipping package.
- (2) The open cell should be keep within one month shelf life.

### 3. Electrical Specifications

#### 3.1 Open Cell Power Consumption ( $T_A = 25 \pm 2 \text{ }^\circ\text{C}$ )

Parameter	Symbol	Value			Unit	Note	
		Min.	Typ.	Max.			
Power Supply Voltage	$V_{CC}$	4.5	5	5.5	V	(1)	
Rush Current	$I_{RUSH}$	-	-	1.91	A	(2)	
Power Supply Current	White Pattern	$I_{CC}$	-	0.96	1.25	A	(3)
	Horizontal Stripe	$I_{CC}$	-	1.27	1.66	A	
	Black Pattern	$I_{CC}$	-	0.75	0.98	A	

Note:

(1) The ripple voltage should be controlled less than 10% of  $V_{CC}$ .

(2) Measurement condition:  $V_{CC}=5\text{V}$ , Rising time =  $470\mu\text{s}$ .

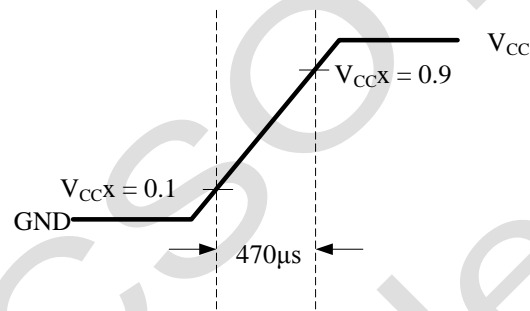

Fig. 3.1  $V_{CC}$  rising time condition

(3) Measurement condition:  $V_{CC} = 5\text{V}$ ,  $T_a = 25 \pm 2 \text{ }^\circ\text{C}$ ,  $F = 75 \text{ Hz}$ . The test patterns are shown as below.

A. White Pattern



B. Horizontal Pattern

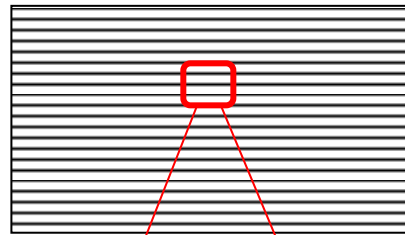

C. Black Pattern

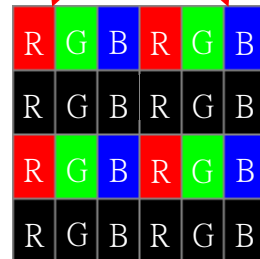

Fig. 3.2 Test patterns

### 3.2 LVDS Characteristics

Parameter		Symbol	Value			Unit	Note
			Min.	Typ.	Max.		
LVDS Interface	Differential Input High Threshold Voltage	$V_{TH}$	+100	-	-	mV	(1)
	Differential Input Low Threshold Voltage	$V_{TL}$	-	-	-100	mV	
	Common Input Voltage	$V_{CM}$	1.0	1.2	1.4	V	
	Differential Input Voltage	$ V_{ID} $	100	-	600	mV	
	Terminating Resistor	$R_T$	87.5	100	112.5	ohm	
CMOS Interface	Input High Threshold Voltage	$V_{IH}$	2.7	-	3.3	V	
	Input Low Threshold Voltage	$V_{IL}$	0	-	0.7	V	

Note:

- (1) The product should be always operated within above ranges.
- (2) The LVDS input signal has been defined as follows:

Single end Signals

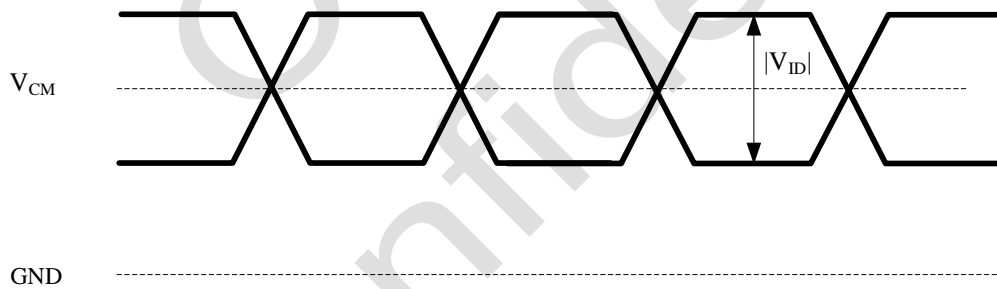

Differential Signal

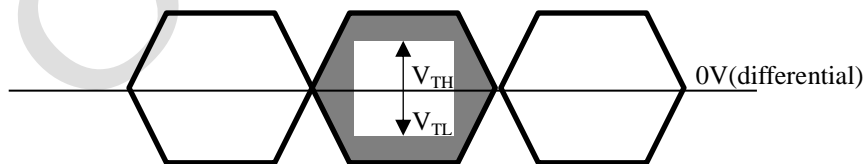

### 3.3 Temperature Specifications

Parameter	Symbol	Specification			Unit	Recommend test pattern	Note
		Min.	Typ.	Max.			
Surface Temperature	$T_{\text{TCON}}$	-	-	105	°C	Horizontal Pattern	(1)
	$T_{\text{Driver}}$	-	-	115		Horizontal Pattern	(1)

Note:

- (1) Any point on the IC surface must be less than Max. specification under any condition ,If the surface temperature is out of the specification, thermal solutions should be applied to avoid be damaged;

### 3.4 Driver IC ESD Specification

The Electro-Static Discharge tolerance of Source COF IC and Gate COF IC is +-2KV tested by ESD Gun. Especially if the LCD module is designed with the Plastic Bezel, we suggest ESD protection solutions should be applied to avoid be damaged, as shown in Fig.3.4 and Fig.3.5.

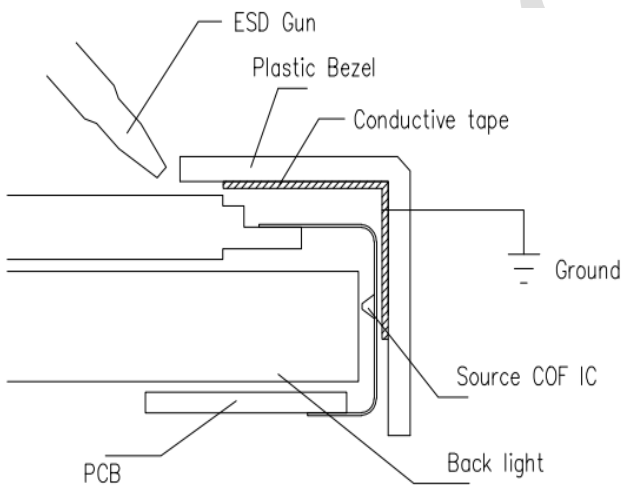

Fig. 3.4 Source COF IC ESD protection

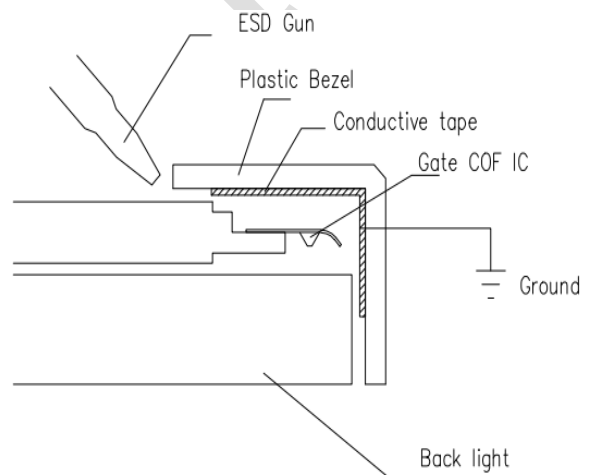

Fig. 3.5 Gate COF IC ESD protection



## 4. Input Terminal Pin Assignment

### 4.1 Interface Pin Assignment

CN1: 300B30-0000RA-M4 (Starconn) or equivalent (see Note (1))

Pin No.	Symbol	Description	Note
1	RO[0]N	Odd LVDS Signal -	
2	RO[0]P	Odd LVDS Signal +	
3	RO[1]N	Odd LVDS Signal -	
4	RO[1]P	Odd LVDS Signal +	
5	RO[2]N	Odd LVDS Signal -	
6	RO[2]P	Odd LVDS Signal +	
7	GND	Ground	
8	ROCLK-	Odd LVDS Clock -	
9	ROCLK+	Odd LVDS Clock +	
10	RO[3]N	Odd LVDS Signal -	
11	RO[3]P	Odd LVDS Signal +	
12	RE[0]N	Even LVDS Signal -	
13	RE[0]P	Even LVDS Signal +	
14	GND	Ground	
15	RE[1]N	Even LVDS Signal -	
16	RE[1]P	Even LVDS Signal +	
17	GND	Ground	
18	RE[2]N	Even LVDS Signal -	
19	RE[2]P	Even LVDS Signal +	
20	RECLK-	Even LVDS Clock -	
21	RECLK+	Even LVDS Clock +	
22	RE[3]N	Even LVDS Signal -	
23	RE[3]P	Even LVDS Signal +	
24	GND	Ground	
25	WP	Write Protect (High: Write Enable, Low or Open: Write Disable )	(2)
26	SCL	I2C Serial Clock (for adjust VCOM)	(2)
27	SDA	I2C Serial Data (for adjust VCOM)	(2)
28	5V	DC power supply	
29	5V	DC power supply	
30	5V	DC power supply	

Note:

(1)The direction of pin assignment is shown as below:

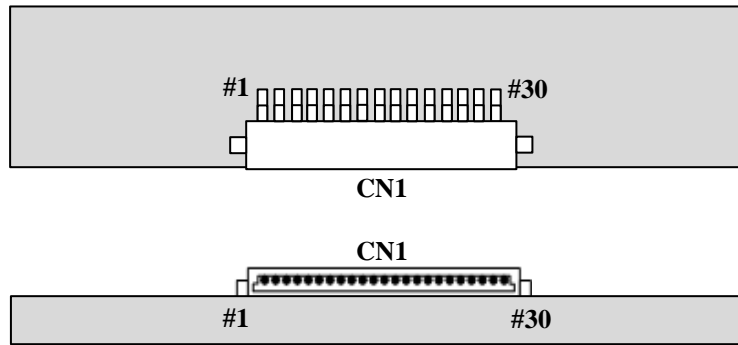

Fig. 4.1 LVDS connector direction sketch map

(2) a. Please let it open (Do not line out from PCBA connector) if it do not used.(for example : TV set )

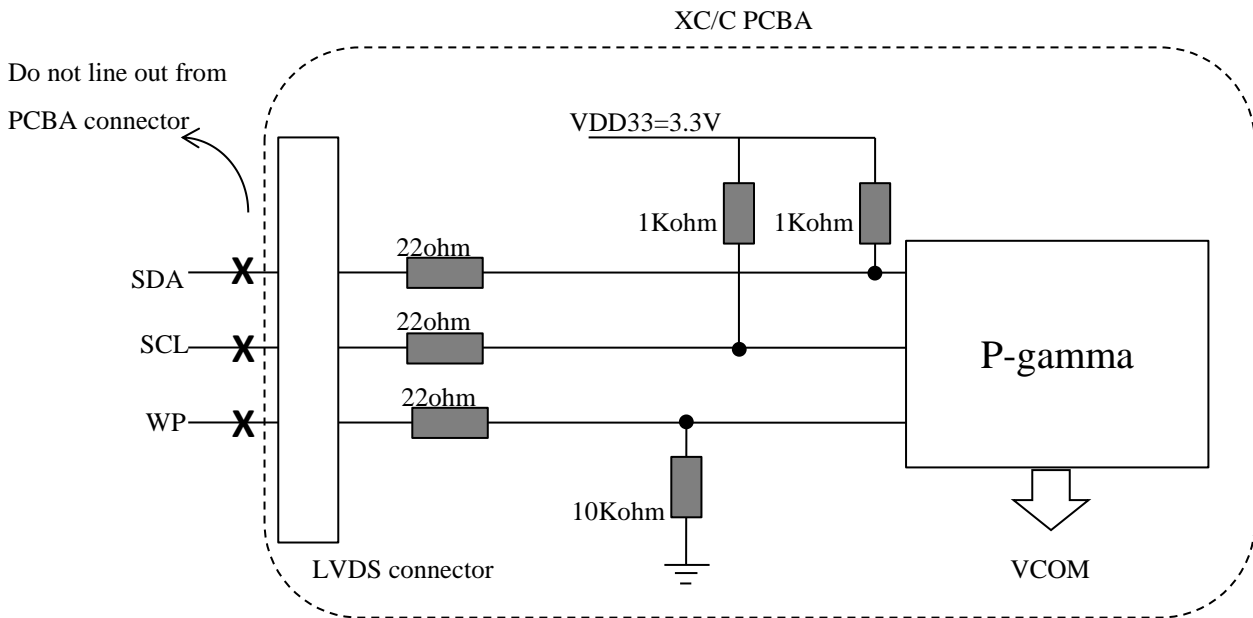

Fig. 4.2 WP/SDA/SCL PCBA set

b. For the VCOM (Flicker) regulation and control, SDA and SCL must pull high in the flicker set, and the flicker set's VDD must ready before the input power (VCC5V)

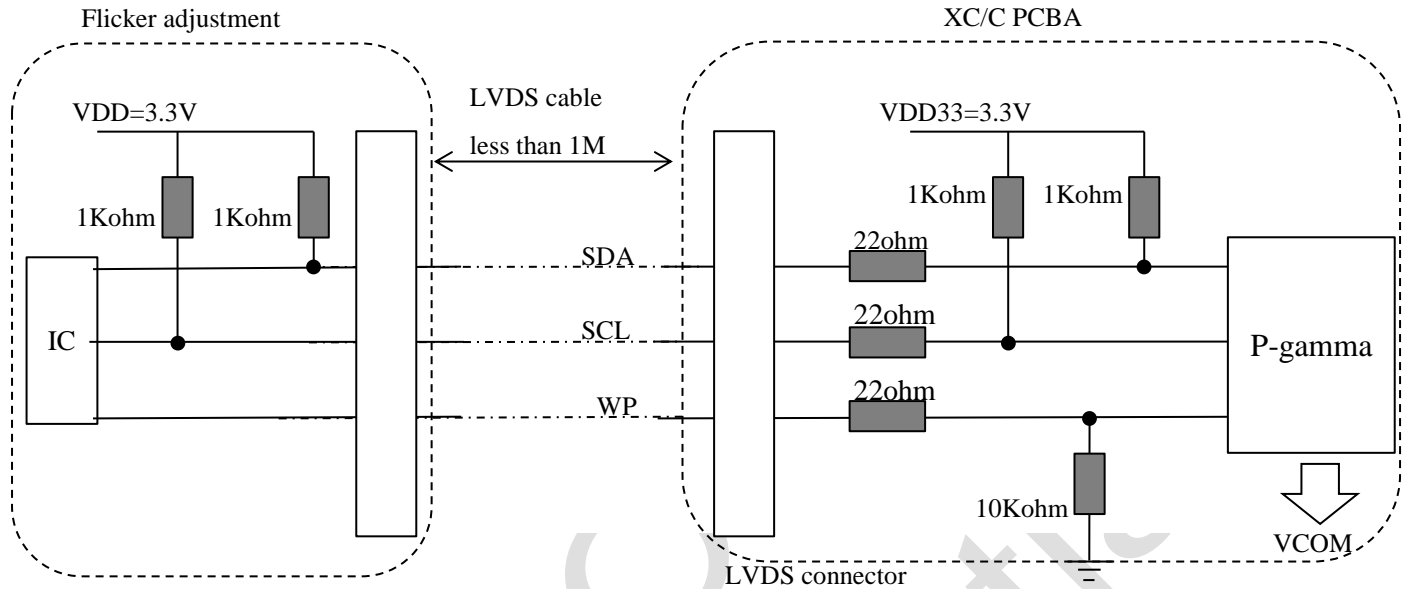

Fig. 4.3 WP/SDA/SCL flicker set

### 4.2 Block Diagram of Interface

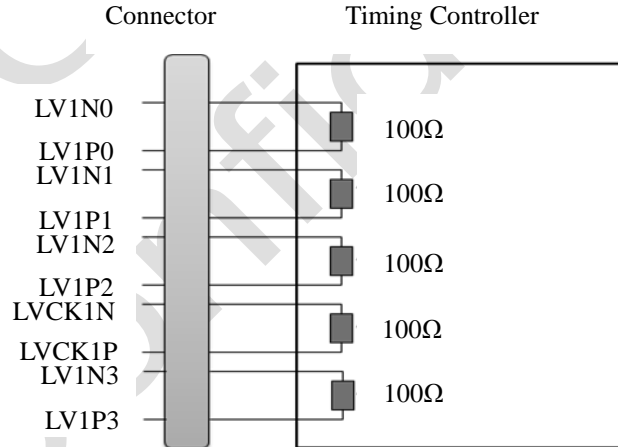

Fig. 4.4 Block diagram of interface

Attention:

- (1) This open cell uses a 100 ohms ( $\Omega$ ) resistor between positive and negative lines of each receiver input.
- (2) LVDS cable impedance shall be 50 ohms per signal line or about 100 ohms per twist-pair line respectively.

## 4.3 LVDS Interface

### 4.3.1 VESA Format

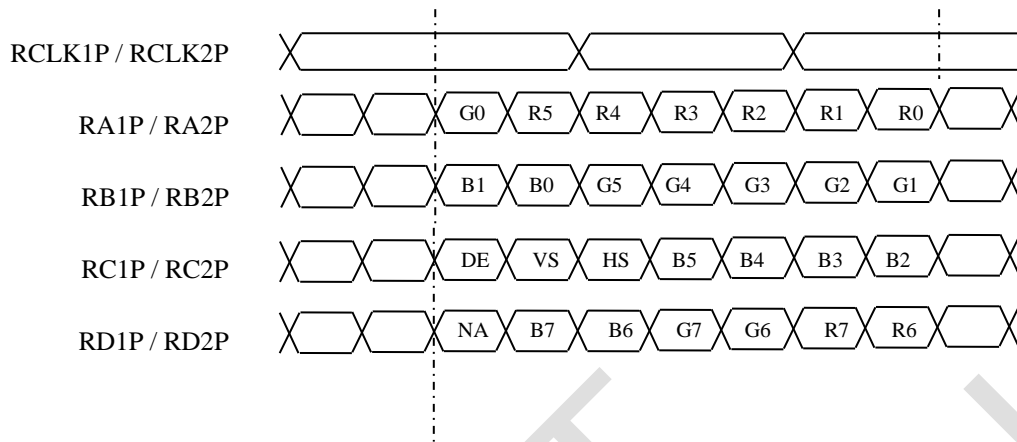

Fig. 4.5 VESA format

## 4.4 V-com Adjustment

(a) Flicker should be adjusted by optimizing the Vcom value in customer LCM line through the I2C interface. (Master & Slave = I2C communication)

Pin. NO.	Symbol	Function	Remark
1	WP	EN	Default:0V Vcom tuning:3.3V (Shouldn't be communicated with I2C device as output level "5V")
2	SCL_I	I2C Interface	I2C Interface
3	SDA_I	I2C Interface	

(b) Flicker should be tuned by correct method according to gamma IC type of each model.

Type	Flicker data saving position	Slave Address							
Genie Type	Gamma IC memory	B7	B6	B5	B4	B3	B2	B1	B0
		1	1	1	0	1	0	0	R/W-

(c)Flicker Should be adjusted by the Dot on/off pattern

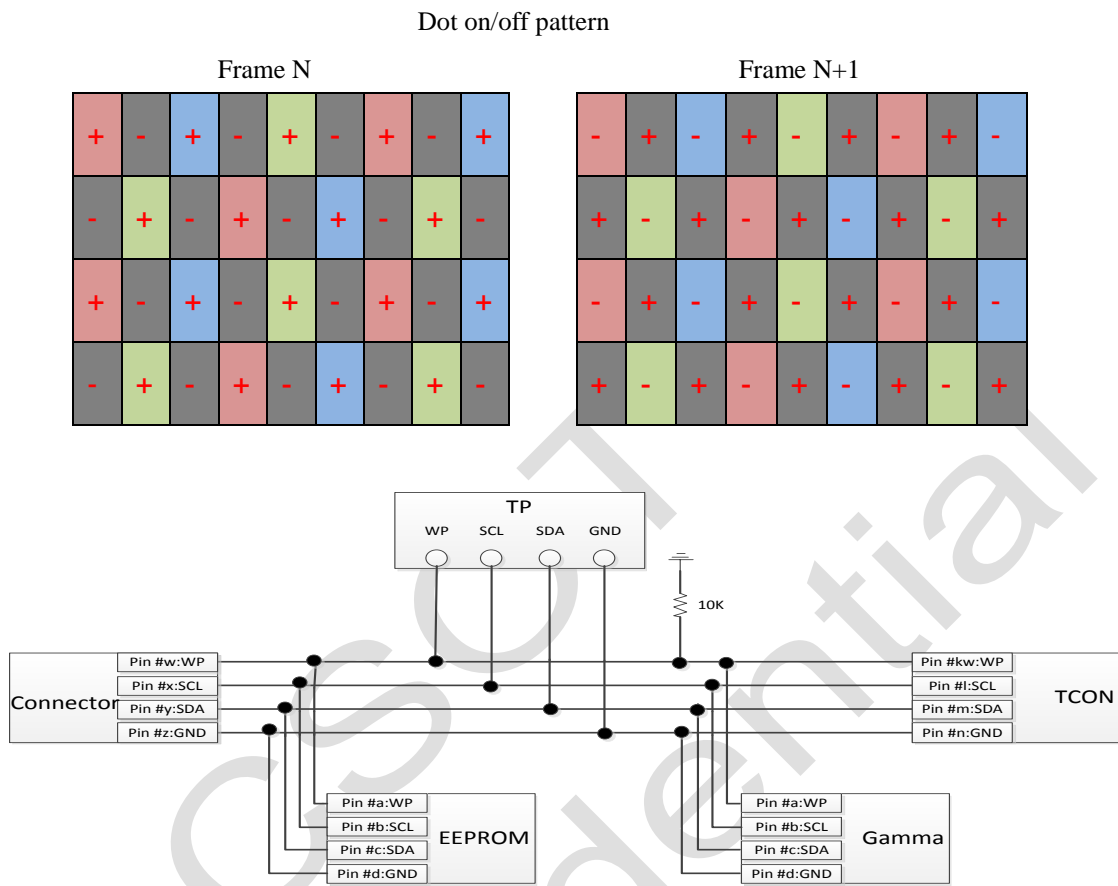

## 5. Interface Timing

### 5.1 Timing Table (DE Only Mode)

Signal	Item	Symbol	Min.	Typ.	Max.	Unit	Note
LVDS Receiver Clock	Frequency	F <sub>clk</sub> (=1/T <sub>clk</sub> )	65	74.25	96	MHz	(1) (2)
	Input cycle to cycle jitter	T <sub>rcj</sub>	—	—	200	ps	(3)
	Spread spectrum modulation range	F <sub>clk_mod</sub>	F <sub>clk</sub> -2%	—	F <sub>clk</sub> +2%	MHz	(4)
	Spread spectrum modulation frequency	F <sub>SSM</sub>	60	—	200	KHz	
LVDS Receiver Data	Receiver Skew Margin	T <sub>RSM</sub>	-400	—	400	ps	(5)
Vertical Active Display Term	Frame Rate	F	48	60	75	Hz	
	Total	T <sub>V</sub>	1092	1125	1380	T <sub>H</sub>	T <sub>V</sub> = T <sub>VD</sub> + T <sub>VB</sub>
	Display	T <sub>VD</sub>	1080				
	Blank	T <sub>VB</sub>	12	45	300	T <sub>H</sub>	
Horizontal Active Display Term	Total	T <sub>H</sub>	1046	1100	1174	T <sub>CLK</sub>	T <sub>H</sub> = T <sub>HD</sub> + T <sub>HB</sub>
	Display	T <sub>HD</sub>	960				
	Blank	T <sub>HB</sub>	86	140	214	T <sub>CLK</sub>	

Note:

(1) The TFT LCD open cell is operated in DE only mode, H sync and V sync input signal have no effect on normal operation.

(2) Please make sure the range of pixel clock follows the following equations:

$$F_{clk(max)} \geq F_{max} \times T_v \times T_h \quad F_{min} \times T_v \times T_h \geq F_{clk(min)}$$

Main frequency Max is 96Mhz without spread spectrum

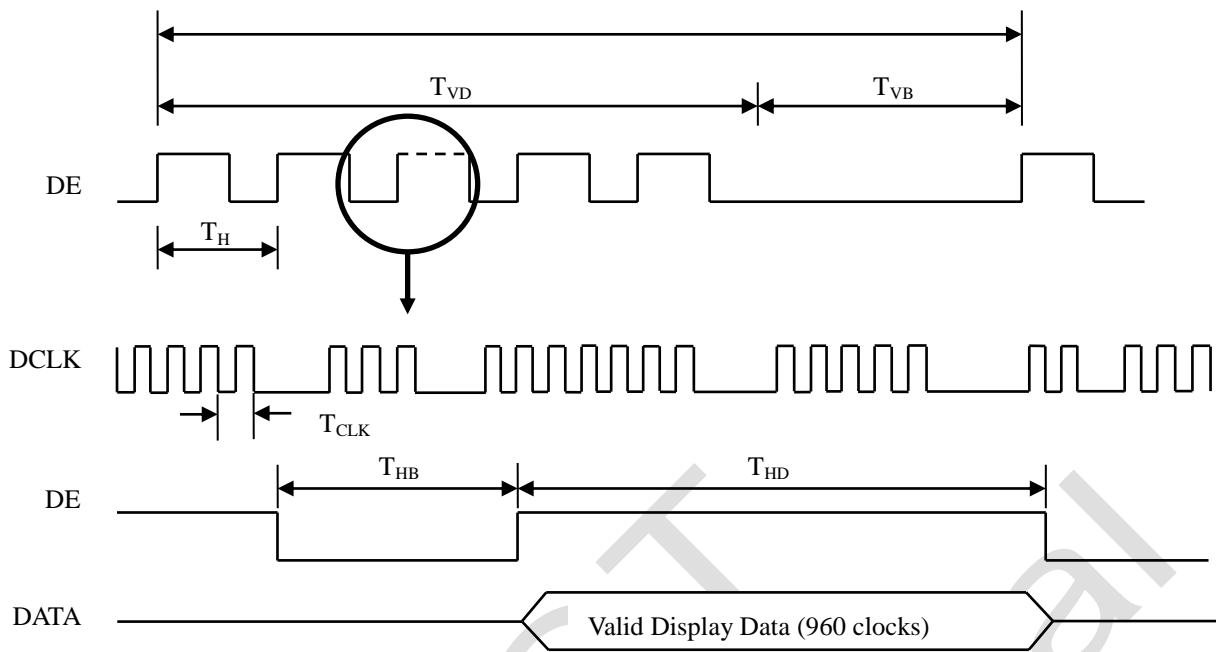

Fig. 5.1 Interface signal timing diagram

(3)The input clock cycle-to-cycle is defined as below figures.

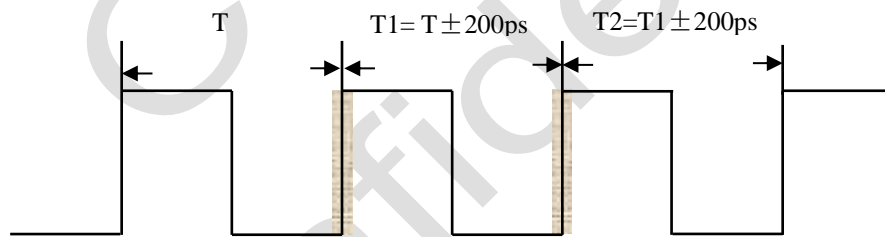

Fig. 5.2 Jitter

(4) The SSCG (Spread Spectrum Clock Generator) is defined as the following figure.

The LVDS SSM's suggestion is off by default, SOC board must test all validation if SOC board open the LVDS SSM.

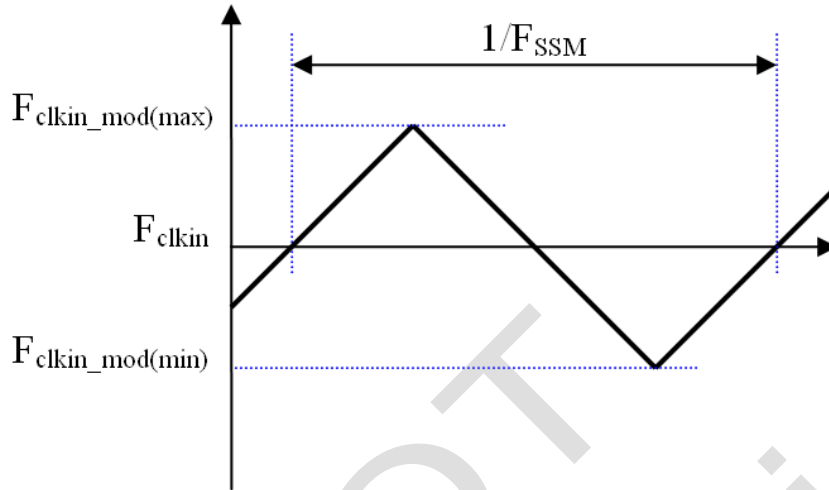

Fig. 5.3 SSCG

(5) The LVDS timing diagram and setup/hold time is defined and showed as the following figure.

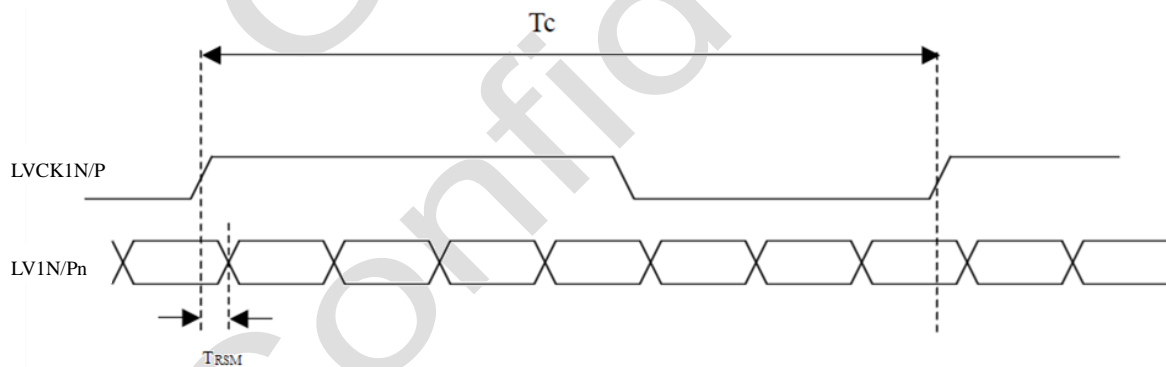

Fig.5.4 LVDS receive interface timing diagram



## 5.2 Power On/Off Sequence

To prevent a latch-up or DC operation of the Open cell, the power on/off sequence should be as the diagram below.

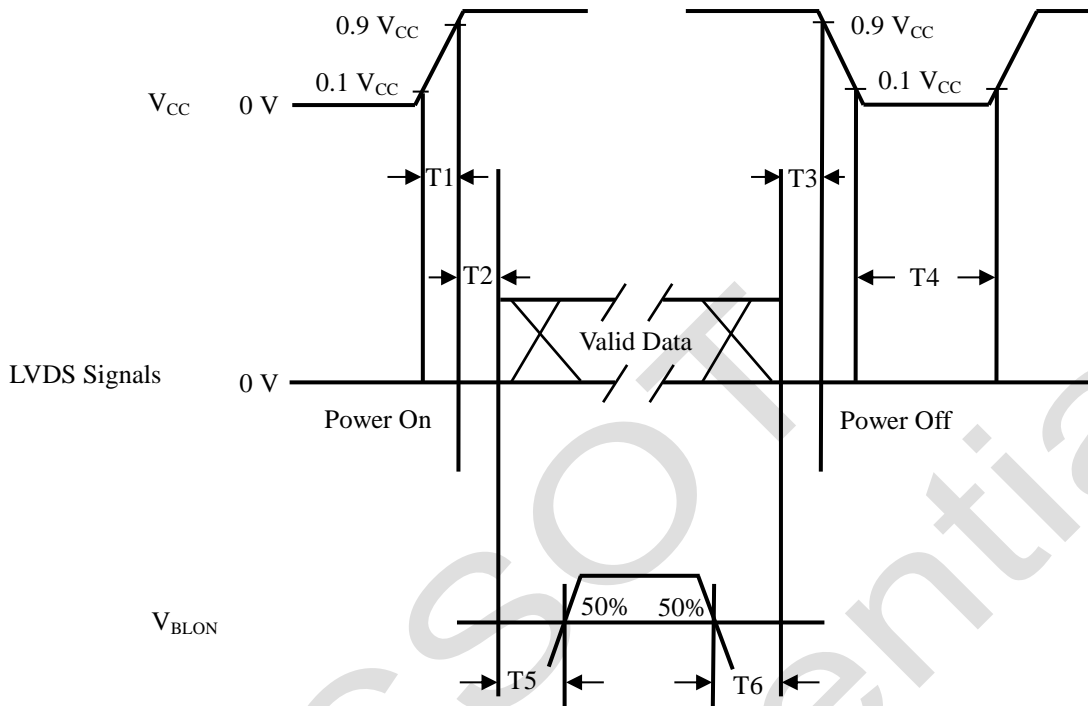

Fig.5.5 Power on/off sequence

Parameter	Values			Unit Min.
	Min.	Typ.	Max.	
T1	0.5	-	10.0	ms
T2	0.0	-	50	ms
T3	0.0	-	50	ms
T4	1000.0	-	-	ms
T5	500.0	-	-	ms
T6	100.0	-	-	ms

### Attention:

- (1) The supply voltage of the external system for the open cell input should follow the definition of V<sub>CC</sub>.
- (2) When the customer's backlight turns on before the LCD operation or the LCD turns off before the backlight turns off, the display may momentarily become abnormal screen.
- (3) In case that V<sub>CC</sub> is in off level, please keep the level of input signals on the low or high impedance. If T2 < 0, that may cause electrical overstress.
- (4) T4 should be measured after the module has been fully discharged between power off and on period.
- (5) Interface signal shall not be kept at high impedance when the power is on.

## 6. Optical Characteristics

### 6.1 Measurement Conditions

The table below is the test condition of optical measurement.

Item	Symbol	Value	Unit
Ambient Temperature	$T_A$	$25 \pm 2$	°C
Ambient Humidity	$H_A$	$50 \pm 10$	%RH
Supply Voltage	$V_{CC}$	5	V
Driving Signal	Refer to the typical value in Chapter 3: Electrical Specification		
Vertical Refresh Rate	$F_R$	60	Hz

To avoid abrupt temperature change during optical measurement, it's suggested to warm up the LCD module more than 60 minutes after lighting the backlight and in the windless environment.

To measure the LCD cell, it is suggested to set up the standard measurement system as Fig. 6.1. The measuring area  $S$  should contain at least 500 pixels of the LCD cell as illustrated in Fig.6.2 ( $A$  means the area allocated to one pixel). In this model, for example, the minimum measuring distance  $Z$  is 370mm when  $\theta$  is 2 degree. Hence, 500mm is the typical measuring distance. This measuring condition is referred to 301-2H of VESA FPDM 2.0 about viewing distance, angle, and angular field of view definition.

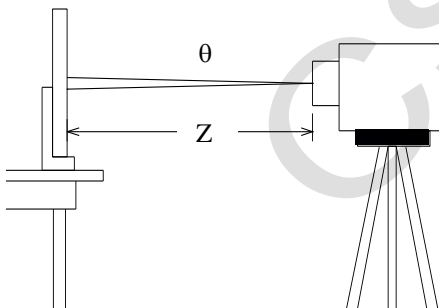

Fig. 6.1 The standard set-up system of measurement

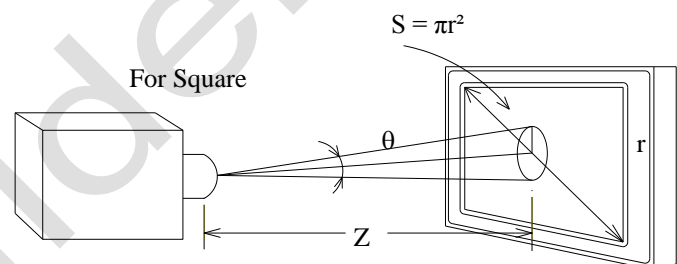

Fig. 6.2 The area  $S$  contains at least 500 pixels to be measured

$$N = \frac{S}{A} \geq 500 \text{ pixels}$$

$N$  means the actual number of the pixels in the area  $S$ .

## 6.2 Optical Specifications

The table below of optical characteristics is measured by MINOLTA CS2000, MINOLTA CA310, ELDIM OPTI Scope-SA and ELDIM EZ contrast in dark room.

Item		Symbol	Condition	Min.	Typ.	Max.	Unit	Note
Static Contrast Ratio		CR	$\theta_H = 0^\circ, \theta_V = 0^\circ$ Normal direction at center point with CSOT's BLU	-	4000	-	-	(1) (2)
Response Time		$T_L$		-	6.5	12	ms	(3)
Center Transmittance		T%		-	4.1	-	%	(2) (4)
Crosstalk		CT-2D		-	-	4%	-	(2) (5)
Color Chromaticity (CIE1931)	Red	$R_X$		Typ. - 0.03	Typ. + 0.03	0.642	-	(2) (6)
		$R_Y$				0.343	-	
	Green	$G_X$				0.314	-	
		$G_Y$				0.610	-	
	Blue	$B_X$				0.149	-	
		$B_Y$				0.054	-	
	White	$W_X$	0.275			-		
		$W_Y$	0.298			-		
Color Gamut		CG	-	72	-	% NTSC		
Viewing Angle	Horizontal	$\theta_{H+}$	-	89	-	Deg.	(7)	
		$\theta_{H-}$	-	89	-			
	Vertical	$\theta_{V+}$	-	89	-			
		$\theta_{V-}$	-	89	-			

Note:

- (1) Definition of static contrast ratio (CR):

It's necessary to switch off all the dynamic and dimming function when measuring the static contrast ratio.

$$\text{Static Contrast Ratio (CR)} = \frac{\text{CR} - \text{W}}{\text{CR} - \text{D}}$$

CR-W is the luminance measured by LMD (light-measuring device) at the center point of the LCD module with full-screen displaying white. The standard setup of measurement is illustrated in Fig. 6.3; CR-D is the luminance measured by LMD at the center point of the LCD module with full-screen displaying black. The LMD in this item is CS2000.

- (2) The LMD in the item could be a spectroradiometer such as (KONICA MINOLTA) CS2000, CS1000 (TOPCON), SR-UL2 or the same level spectroradiometer. Other display color analyzer (KONICA MINOLTA) CA210, CA310 or (TOPCON) BM-7 could be involved after being calibrated with a spectroradiometer on each stage of a product.

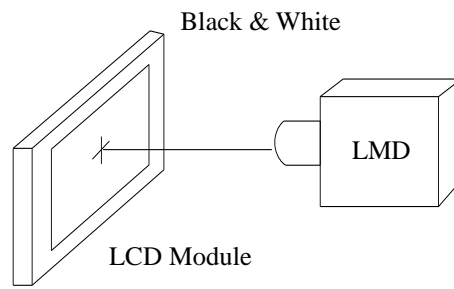

Fig. 6.3 The standard setup of CR measurement

(3) Response time  $T_L$  is defined as the average transition time in the response time matrix. The table below is the response time matrix in which each element  $t_{X \text{ to } Y}$  is the transition time from luminance ratio X to Y. X and Y are two different luminance ratios among 0%, 25%, 50%, 75%, and 100% luminance. The transition time  $t_{X \text{ to } Y}$  is defined as the time taken from 10% to 90% of the luminance difference between X and Y ( $X < Y$ ) as illustrated in Fig.6.4. When  $X > Y$ , the definition of  $t_{X \text{ to } Y}$  is the time taken from 90% to 10% of the luminance difference between X and Y. The response time is optimized on refresh rate  $F_r = 60\text{Hz}$ .

Measured Transition Time		Luminance Ratio of Previous Frame				
		0%	25%	50%	75%	100%
Luminance Ratio of Current Frame	0%		$t_{25\% \text{ to } 0\%}$	$t_{50\% \text{ to } 0\%}$	$t_{75\% \text{ to } 0\%}$	$t_{100\% \text{ to } 0\%}$
	25%	$t_{0\% \text{ to } 25\%}$		$t_{50\% \text{ to } 25\%}$	$t_{75\% \text{ to } 25\%}$	$t_{100\% \text{ to } 25\%}$
	50%	$t_{0\% \text{ to } 50\%}$	$t_{25\% \text{ to } 50\%}$		$t_{75\% \text{ to } 50\%}$	$t_{100\% \text{ to } 50\%}$
	75%	$t_{0\% \text{ to } 75\%}$	$t_{25\% \text{ to } 75\%}$	$t_{50\% \text{ to } 75\%}$		$t_{100\% \text{ to } 75\%}$
	100%	$t_{0\% \text{ to } 100\%}$	$t_{25\% \text{ to } 100\%}$	$t_{50\% \text{ to } 100\%}$	$t_{75\% \text{ to } 100\%}$	

$t_{X \text{ to } Y}$  means the transition time from luminance ratio X to Y.

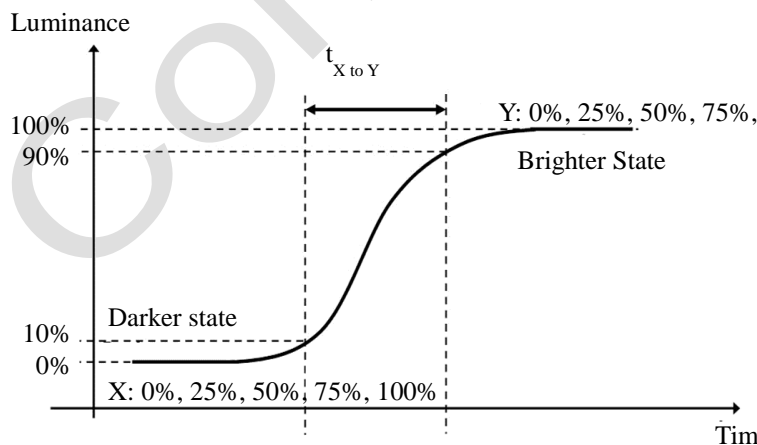

Fig. 6.4 The definition of  $t_{X \text{ to } Y}$

All the transition time is measured at the center point of the LCD module by ELDIM OPTI Scope-SA.

## (4) Definition of center Transmittance (T %):

The transmittance is measured with full white pattern (Gray 255)

$$\text{Static Contrast Ratio (CR)} = \frac{\text{Luminance of LCD module}}{\text{Luminance of backlight}}$$

## (5) Definition of the crosstalk(CT-2D):

YA = Luminance of measured location without gray level 255 pattern (cd/m<sup>2</sup>)

YB = Luminance of measured location with gray level 255 pattern(cd/m<sup>2</sup>)

$$\text{Definition of the crosstalk: } CT = \frac{YB - YA}{YA}$$

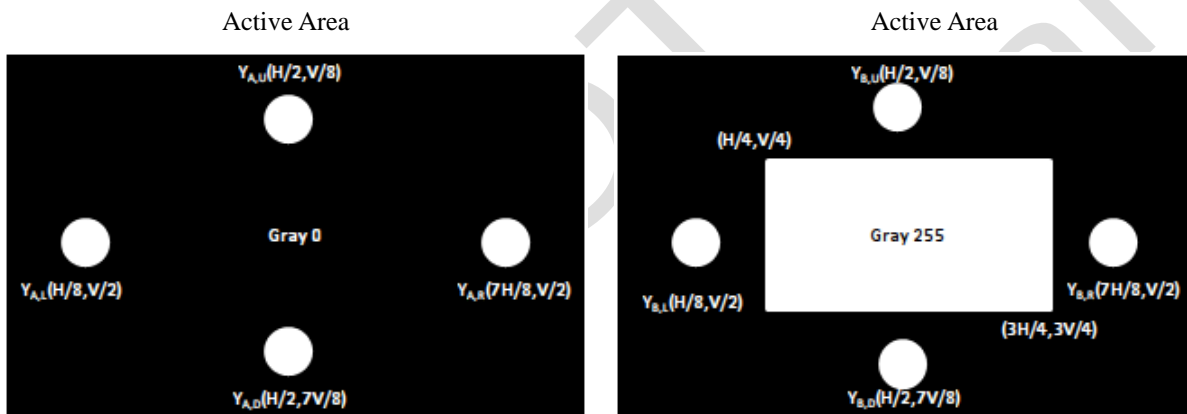

Fig. 6.5 The definition of 2D mode crosstalk

## (6) Definition of color chromaticity:

Each chromaticity coordinates (x, y) are measured in CIE1931 color space when full-screen displaying primary color R, G, B and white. The color gamut is defined as the fraction in percent of the area of the triangle bounded by R, G, B coordinates and the area is defined by NTSC 1953 color standard in the CIE color space. Chromaticity coordinates are measured by CS2000 and the standard setup of measurement is shown in Fig. 6.6.

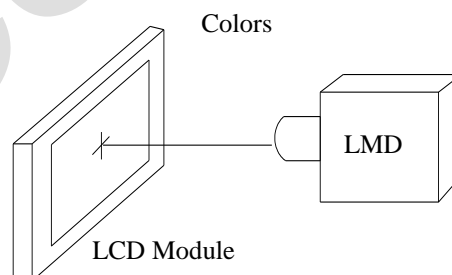

Fig. 6.6 The standard setup of color chromaticity measurement

(7) Definition of viewing angle coordinate system ( $\theta_H$ ,  $\theta_V$ ):

The contrast ratio is measured at the center point of the LCD module. The viewing angles are defined at the angle that the contrast ratio is larger than 10 at four directions relative to the perpendicular direction of the LCD module (two vertical angles: up  $\theta_{V+}$  and down  $\theta_{V-}$ ; and two horizontal angles: right  $\theta_{H+}$  and left  $\theta_{H-}$ ) as illustrated in Fig. 6.7. The contrast ratio is measured by ELDIM EZ Contrast.

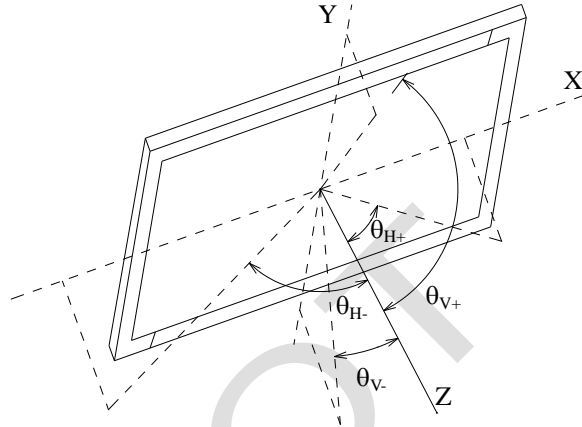
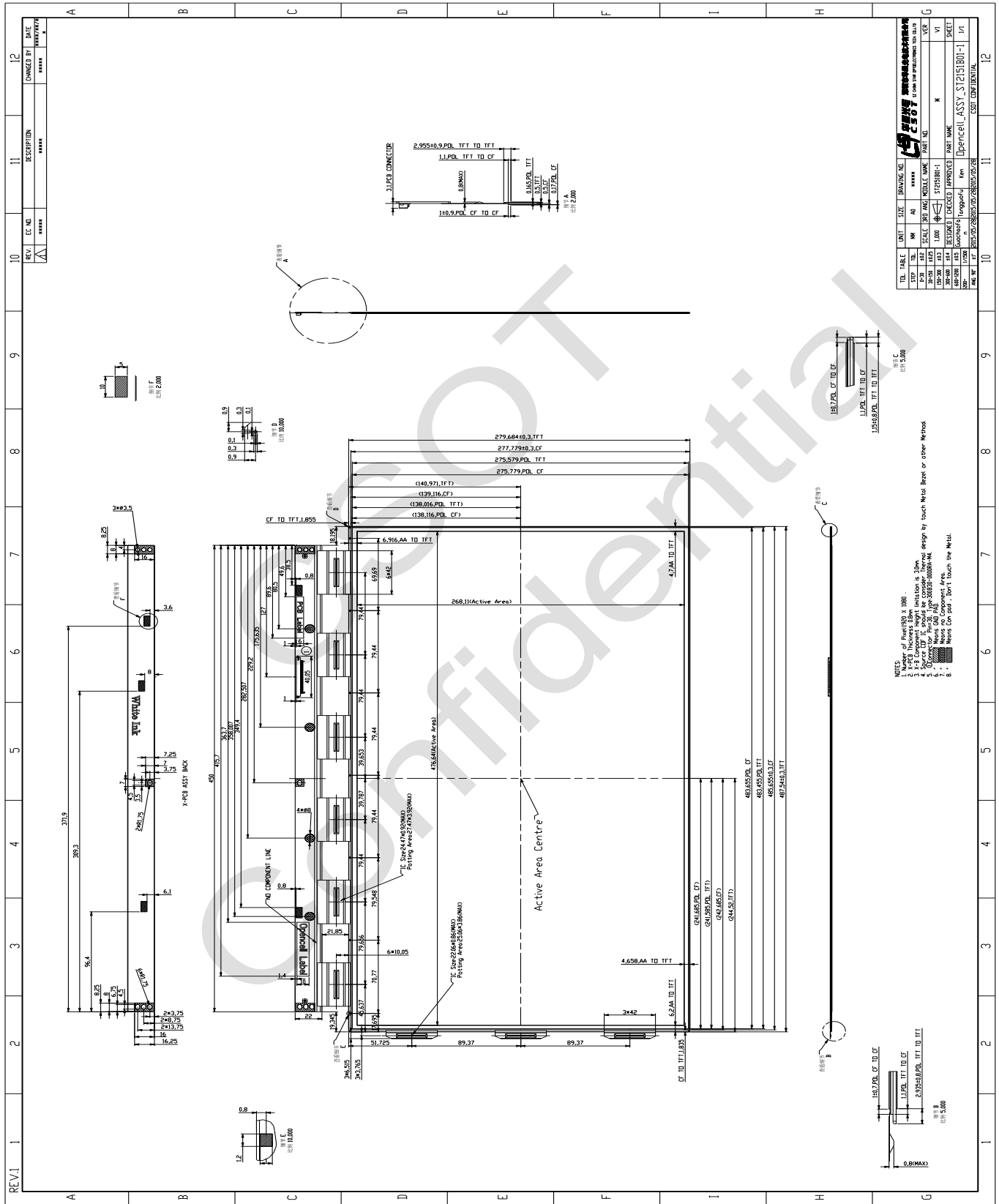

Fig. 6.7 Viewing angle coordination system

## 7. Mechanical Characteristics

### 7.1 Mechanical Specification



## 7.2 Packing Specifications and Method

### The Packing Specifications and Method

Item	Specification		
	Quantity	Dimension (mm)	Weight (kg)
Open cell	/	487.54(L)*279.684(W)*1.335(H)	Net Weight:0.42±5%
Packing Box	20pcs/box	610 (L) * 468 (W) * 130 (H)	Net Weight: 9 (Max.) Gross Weight: 10.3(Max.)
Pallet	1	1250 (L) * 1000 (W) * 160 (H)	Net Weight: 14.5
Stack Layer	7		
Boxes per Pallet	28		
Pallet after Packing	560pcs/pallet	1250 (L) * 1000 (W) * 1032 (H)	Gross Weight: 301

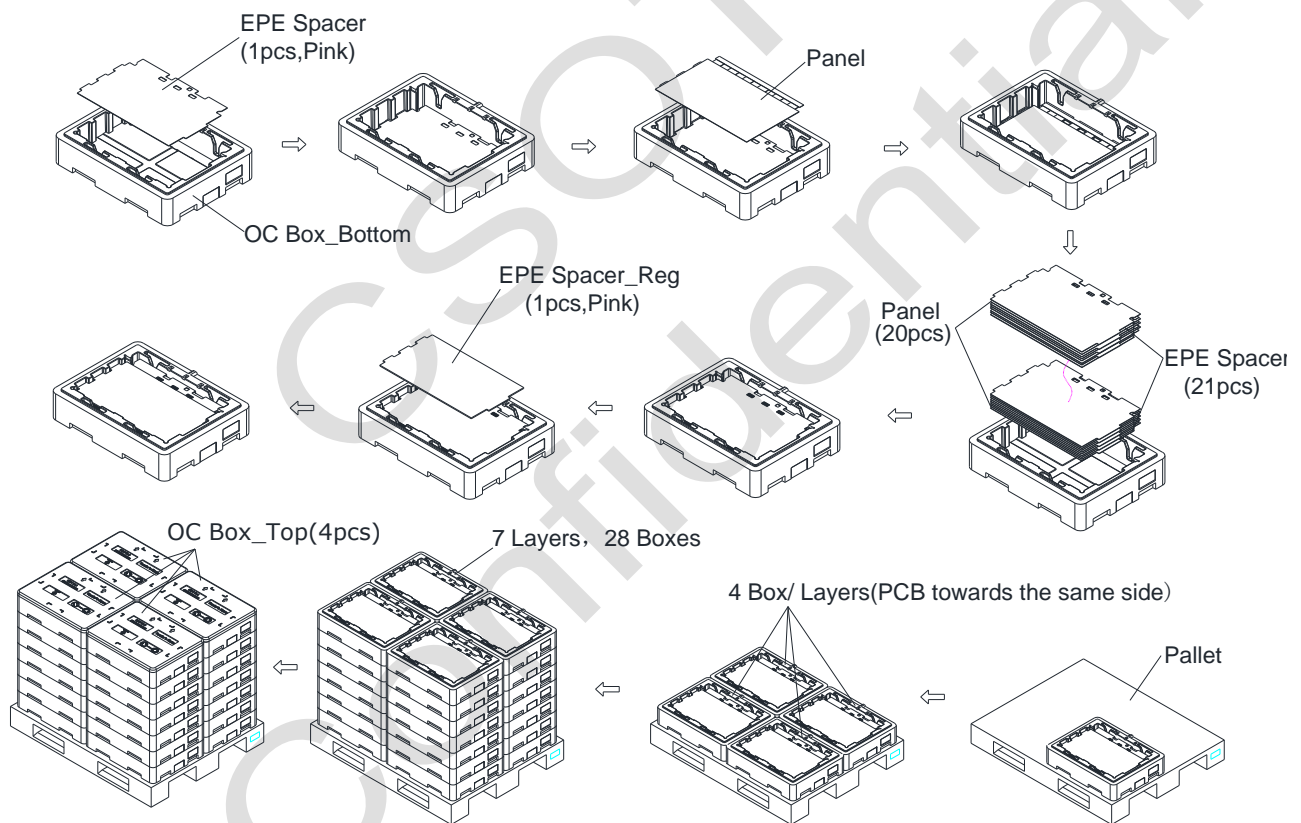



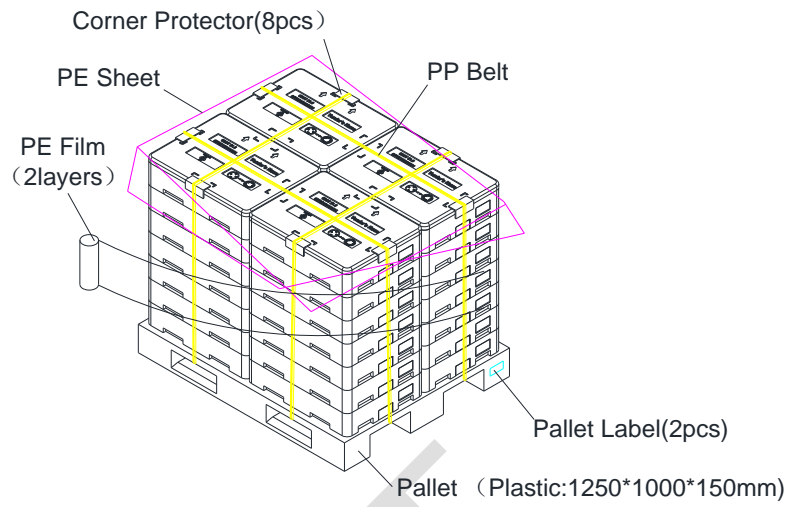
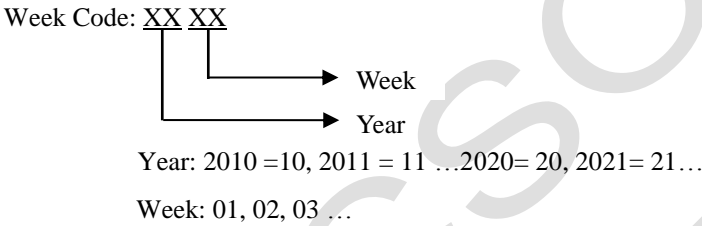
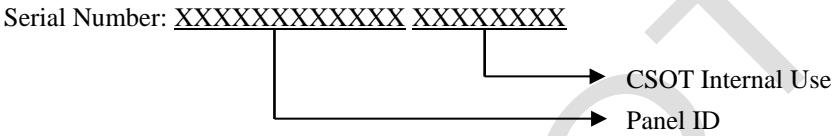
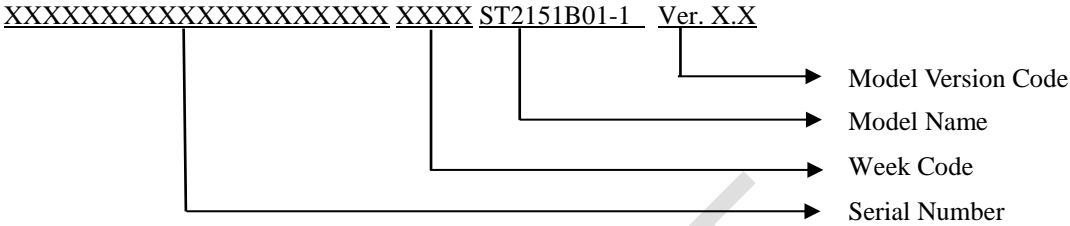

Fig. 7.1 The packing method

8. Definition of Labels

8.1 Open Cell Label



Model Name: ST2151B01-1  
Ver.X.X: Version, for example: 0.1, 0.2, ... , 1.1, 1.2, ... , 2.1, 2.2, ...

8.2 Carton Label



For RoHS compliant products, CSOT will add RoHS for identification.

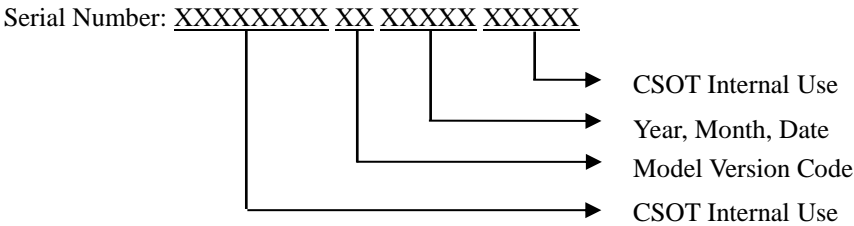

Manufactured Date:

Year: 2010 = 10, 2011 = 11...2020 = 20, 2021 = 21...

Month: 1~9, A~C, for Jan. ~ Dec.

Date: 01~31, for 1st to 31st

Model Version Code: Version of product, for example: 01, 02, 11, 12...

8.3 Pallet Label



Model Name: ST2151B01-1

Serial Number: XXXXXX XX XXXXXX XXXXXX

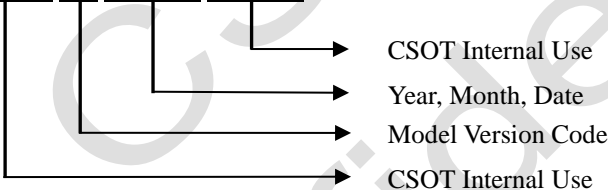

Confidential

## 9. Precautions

### 9.1 Assembly and Handling Precautions

- (1) The device listed in the product specification sheets was designed and manufactured for TV application only.
- (2) Do not apply rough force such as bending or twisting to the open cell during assembly.
- (3) It is recommended to assemble or install a open cell into the user's system in clean working areas. The dust and oil may cause electrical shorter damage the polarizer.
- (4) Do not apply pressure or impulse to the open cell to prevent the damage to the open cell.
- (5) Always follow the correct power-on sequence. This can prevent the damage and latch-up to the LSI chips.
- (6) Do not plug in or pull out the interface connector while the open cell is in operation.
- (7) Use soft dry cloth without chemicals for cleaning because the surface of polarizer is very soft and easily be scratched.
- (8) Moisture can easily penetrate into the open cell and may cause the damage during operation.
- (9) High temperature or humidity may deteriorate the performance of the open cell. Please store open cell in the specified storage conditions.
- (10) When ambient temperature is lower than 10 °C, the display quality might be deteriorated. For example, the response time will become slow.

### 9.2 Safety Precautions

- (1) If the liquid crystal material leaks from the panel, it should be kept away from the eyes or mouth. In case of contact with hands, skin or clothes, it has to be washed away thoroughly with soap.
- (2) After the open cell end of life, it is not harmful in case of normal operation and storage.