



# MODEL: ST2751A01-2

Ver. 1.1

Date: 26.Sep.2012

Customer's Approval		CSOT	
Signature	Date	Approved By Product Director	Date
		Name: Richard Lung	
		Signature:	
		Reviewed By PM Manager	Date
		Name: Aaron Tu	
		Signature:	
		Reviewed By Project Leader	Date
		Name: LC Liao	
		Signature:	
		Reviewed By PM	Date
		Name: Qingyan Ji	
		Signature:	

## Contents

1. General Description .....	4
1.1 Product Features .....	4
1.2 Overview .....	4
1.3 General Information .....	4
2. Absolute Maximum Ratings .....	5
2.1 Absolute Maximum Ratings (TA = 25 ± 2 °C) .....	5
2.2 Environment Requirement (Based on CSOT Module MT2751A01-1) .....	5
2.3 Absolute ratings of Environment (Open Cell) .....	5
3. Electrical Specification .....	6
3.1 Open cell Power Consumption (TA = 25 ± 2 °C) .....	6
3.2 Mini-LVDS Characteristics .....	7
4. Input Terminal Pin Assignment .....	8
4.1 Interface pin assignment .....	8
4.2 Block Diagram of Interface .....	10
4.3 Mini-LVDS Interface .....	11
4.3.1 Cell Structure .....	11
4.3.2 6 Pair Mode Data Mapping .....	11
4.4 Pattern FOR Vcom Adjustment .....	11
5. Interface Timing .....	12
5.1 Timing Table (DE Only Mode) .....	12
5.2 Power On/Off Sequence .....	13
6. Optical Characteristics .....	14
6.1 Measurement Conditions .....	14
6.2 Optical Specifications .....	15
7. Mechanical Characteristics .....	18
7.1 Mechanical Specification .....	18
7.2 Packing .....	19
7.2.1 Packing Specifications .....	19
7.2.2 Packing Method .....	19
8. Definition of Labels .....	20
8.1 Open Cell Label .....	20
8.2 Carton Label .....	20
8.3 Pallet Label .....	22
9. Precautions .....	23
9.1 Assembly and Handling Precautions .....	23
9.2 Safety Precautions .....	23

## Revision History

Version	Date	Page (New)	Section	Description	Revision by
Ver. 1.1	24.Sep.2012	All	All	Preliminary specification was first issued.	Qingyan Ji

CSOT  
Confidential

## 1. General Description

### 1.1 Product Features

- **HD Resolution (1366 x 768)**
- **High Contrast Ratio: 3000:1**
- **Fast Response Time**
- **Ultra Wide Viewing Angle: 178° (H)/178° (V) (CR ≥ 10)**
- **DE (Data Enable) Mode**
- **LVDS (Low Voltage Differential Signaling) Interface**

### 1.2 Overview

ST2751A01-1 is a diagonal 27.5" color active matrix LCD open cell with 1ch-LVDS interface. This open cell is a transmissive type display operating in the normally black mode. It supports 1366 x 768 HD resolution and can display up to 16.7M colors (8-bit). Each pixel is divided into Red, Green and Blue sub-pixels which are arranged in horizontal stripe. There is no backlight built-in.

This open cell dedicates for LCD TV products and provides excellent performance which includes high transmittance, ultra wide viewing angle and high color depth. CSOT open cell comply with ROHS for identification.

### 1.3 General Information

Item	Specification	Unit	Note
Active Area	607.5285 (H) x 345.0240 (V)	mm	
Cell Size	620.4675 (H) x 359.4850 (V) x 1.9438 (D)	mm	
Driving Scheme	a-Si TFT Active Matrix	-	
Number of Pixels	1366 x 768	pixel	
Pixel Pitch (Sub Pixel)	0.44475 (H) x 0.14975 (V)	mm	
Pixel Arrangement	RGB Horizontal Stripe	-	
Display Colors	16.7 M	color	8-bit
Display Mode	Transmissive Mode, Normally Black	-	
Glass thickness (Array / CF)	0.7 / 0.7	mm	
Color Chromaticity	R = 0.610, 0.334 G = 0.341, 0.608 B = 0.158, 0.065 W = 0.280, 0.290		Typical value measured at CSOT's module: MT2751A01-1
Contrast Ratio	3000:1 (Typ.)		
Cell Transmittance	7.2% (Typ.)	%	
View Angle (CR>10)	+ 89 / - 89 (H), + 89 / - 89 (V) (Typ.)		
Polarizer (CF side)	Low Haze 2%		
Polarizer (TFT side)	Hard Coating (3H)		

## 2. Absolute Maximum Ratings

### 2.1 Absolute Maximum Ratings ( $T_A = 25 \pm 2 \text{ }^\circ\text{C}$ )

The followings are maximum values which, if exceeded, may cause damage to the unit.

Item	Symbol	Value		Unit
		Min.	Max.	
Power Supply Voltage	$V_{CC}$	- 0.3	6.0	V
Input Signal Voltage	$V_{IN}$	- 0.3	3.6	V

### 2.2 Environment Requirement (Based on CSOT Module MT2751A01-1)

(1) Temperature and relative humidity range are shown as below.

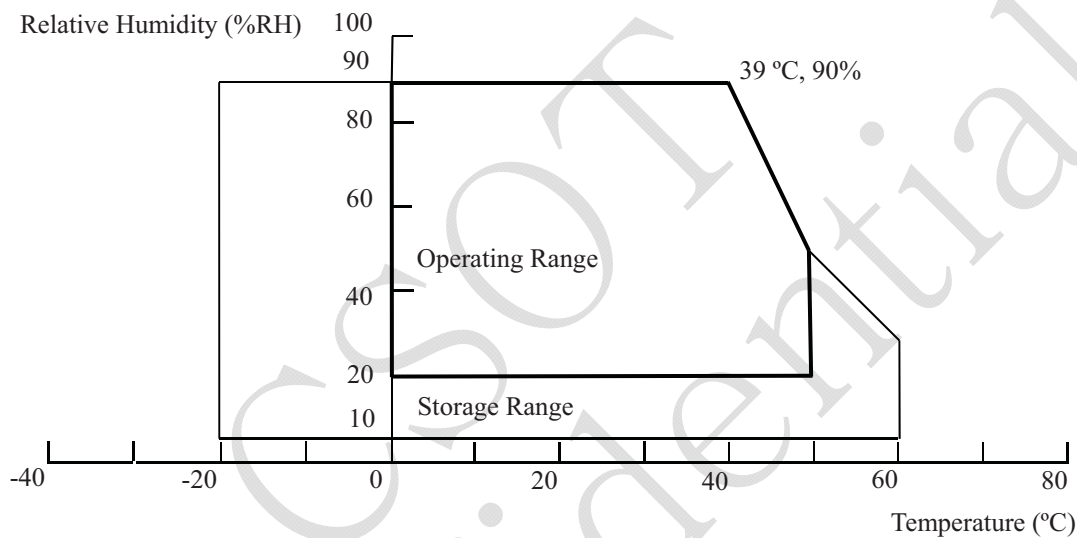

Fig. 2.1 Operating and storage environment

- (a) 90%RH maximum ( $T_A < 39 \text{ }^\circ\text{C}$ ).
- (b) Wet-bulb temperature should be 39 °C maximum ( $T_A > 39 \text{ }^\circ\text{C}$ ).
- (c) No condensation.

(2) The storage temperature is between - 20 °C to 60 °C, and the operating ambient temperature is between 0 °C to 50 °C.

The maximum operating temperature is based on the test condition that the surface temperature of display area is less than or equal to 65 °C with LCD module in a temperature controlled chamber alone. Thermal management should be considered in final product design to prevent the surface temperature of display area from being over 65 °C. The range of operating temperature may degrade in case of improper thermal management in the end product design.

(3) The rating of environment is based on LCD module. Leave LCD cell alone, this environment condition can't be guaranteed.

Except LCD cell, the customer has to consider the ability of other parts of LCD module and LCD module process.

### 2.3 Absolute ratings of Environment (Open Cell)

When storing open cell as spares for a long time, please follow the precaution instructions:

- (1) Do not store the module in high temperature and high humidity for a long time. It is highly recommended to store the module with temperature from 20 °C to 30 °C in normal humidity ( $50 \pm 10\%RH$ ) with shipping package.
- (2) The open cell should be keep within one month shelf life

### 3. Electrical Specification

#### 3.1 Open cell Power Consumption (TA = 25 ± 2 °C)

Parameter		Symbol	Value			Unit	Note
			Min.	Typ.	Max.		
Power Supply Voltage		V <sub>CC</sub>	4.6	5.0	5.4	V	(1)
Rush Current		I <sub>RUSH</sub>	-	-	1.01	A	(2)
Power Supply Current	White Pattern	I <sub>CC</sub>	-			A	(3)
	Vertical Stripe	I <sub>CC</sub>	-			A	
	Black Pattern	I <sub>CC</sub>	-			A	

Note:

(1) The ripple voltage should be controlled less than 10% of V<sub>CC</sub>.

(2) Measurement condition: V<sub>CC</sub> rising time = 470 μs.

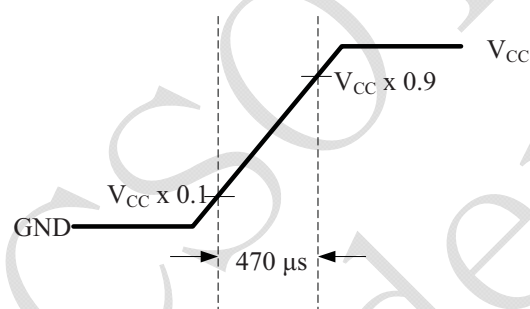

Fig. 3.1 V<sub>CC</sub> rising time condition

(3) Measurement condition: V<sub>CC</sub> = 5 V, Ta = 25 ± 2 °C, F = 60 Hz. The test patterns are shown as below.

A. White Pattern



C. Black Pattern



B. Vertical Stripe Pattern

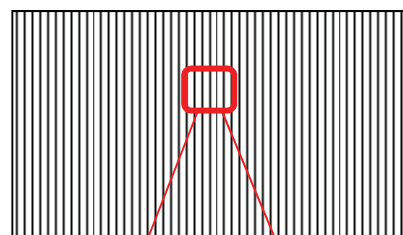

B	B	B	B	B	B
G	G	G	G	G	G
R	R	R	R	R	R
B	B	B	B	B	B
G	G	G	G	G	G
R	R	R	R	R	R

Fig. 3.2 Test patterns

### 3.2 Mini-LVDS Characteristics

Parameter		Symbol	Value			Unit	Note
			Min.	Typ.	Max.		
Mini-LVDS Interface	Common Input Voltage	$V_{CM}$	0.5	-	1.4	V	(1)
	Differential Input Voltage	$ V_{ID} $	150	200	300	mV	(2)
	mini-LVDS Input Leakage Current	IDL	-1	-	1	$\mu A$	(3)

Note:

(1) The mini-LVDS input signal has been defined as follows:

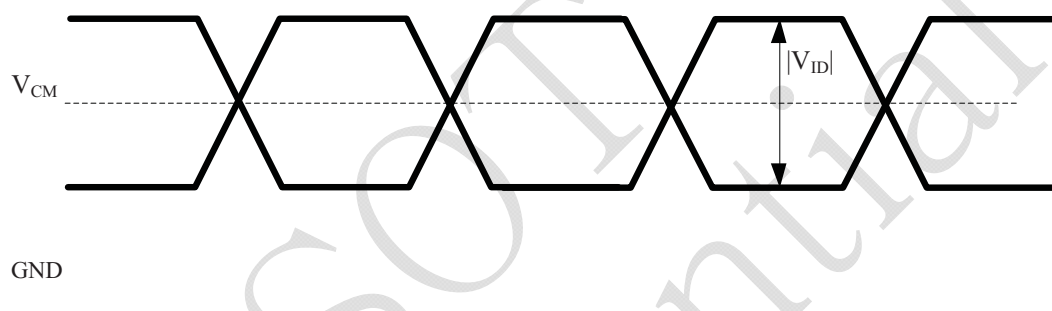

Fig. 3.3 Mini-LVDS input signal

$$(2) V_{CM} = (V_{CLKP} + V_{CLKN}) / 2 \text{ or } V_{CM} = (V_{DxxP} + V_{DxxN}) / 2$$

$$(3) V_{ID} = V_{CLKP} - V_{CLKN} \text{ or } V_{ID} = V_{DxxP} - V_{DxxN}$$

The typical mini-LVDS swing level of peak to peak is 400mV, ranging from -200mV to +200mV

## 4. Input Terminal Pin Assignment

### 4.1 Interface pin assignment

X + C Board CN1: 196417-60041-3 (P-two) or equivalent (see Note (1))

Pin No.	Symbol	Description	Note
1	VCC	Power Supply ,+5 V DC regulated	
2	VCC	Power Supply ,+5 V DC regulated	
3	VCC	Power Supply ,+5 V DC regulated	
4	VCC	Power Supply ,+5 V DC regulated	
5	NC	For CSOT users only	(2)
6	NC	For CSOT users only	(2)
7	GND	Ground	
8	GND	Ground	
9	GND	Ground	
10	GND	Ground	
11	NC	For CSOT users only	(2)
12	GND	Ground	
13	MLV0P	1st Channel mini-LVDS Data Input (0+)	
14	MLV0N	1st Channel mini-LVDS Data Input (0-)	
15	MLV1P	1st Channel mini-LVDS Data Input (1+)	
16	MLV1N	1st Channel mini-LVDS Data Input (1-)	
17	MLV2P	1st Channel mini-LVDS Data Input (2+)	
18	MLV2N	1st Channel mini-LVDS Data Input (2-)	
19	GND	Ground	
20	MLVCKP	1st Channel mini-LVDS Clock Input (+)	
21	MLVCKN	1st Channel mini-LVDS Clock Input (-)	
22	GND	Ground	
23	MLV3P	1st Channel mini-LVDS Clock Input (3+)	
24	MLV3N	1st Channel mini-LVDS Clock Input (3-)	
25	MLV4P	1st Channel mini-LVDS Clock Input (4+)	
26	MLV4N	1st Channel mini-LVDS Clock Input (4-)	
27	MLV5P	1st Channel mini-LVDS Clock Input (5+)	
28	MLV5N	1st Channel mini-LVDS Clock Input (5-)	
29	GND	Ground	
30	NC	For CSOT users only	(2)
31	POL	Polarity inversion signal for source driver	
32	TP1	Latch signal for source driver	
33	GND	Ground	



34	OE	Scan driver output enable	
35	CKV	Scan driver clock	
36	GVON	Control signal of gate voltage shaping	
37	STV	Scan driver start pulse	
38	NC	For CSOT users only	(2)
39	NC	For CSOT users only	(2)
40	NC	For CSOT users only	(2)
41	NC	For CSOT users only	(2)
42	NC	For CSOT users only	(2)
43	NC	For CSOT users only	(2)
44	NC	For CSOT users only	(2)
45	NC	For CSOT users only	(2)
46	NC	For CSOT users only	(2)
47	NC	For CSOT users only	(2)
48	GND	Ground	
49	NC	For CSOT users only	(2)
50	NC	For CSOT users only	(2)
51	NC	For CSOT users only	(2)
52	NC	For CSOT users only	(2)
53	NC	For CSOT users only	(2)
54	NC	For CSOT users only	(2)
55	NC	For CSOT users only	(2)
56	NC	For CSOT users only	(2)
57	NC	For CSOT users only	(2)
58	NC	For CSOT users only	(2)
59	GND	Ground	
60	GND	Ground	

Note:

(1) The direction of pin assignment is shown as below:

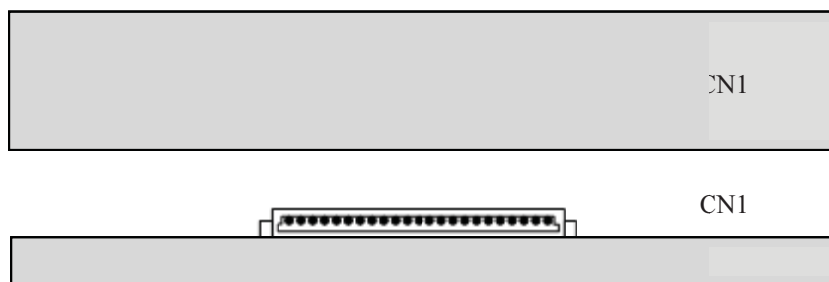

Fig. 4.1 Mini-LVDS direction sketch map

(2) For CSOT internal only, please let it open.

## 4.2 Block Diagram of Interface

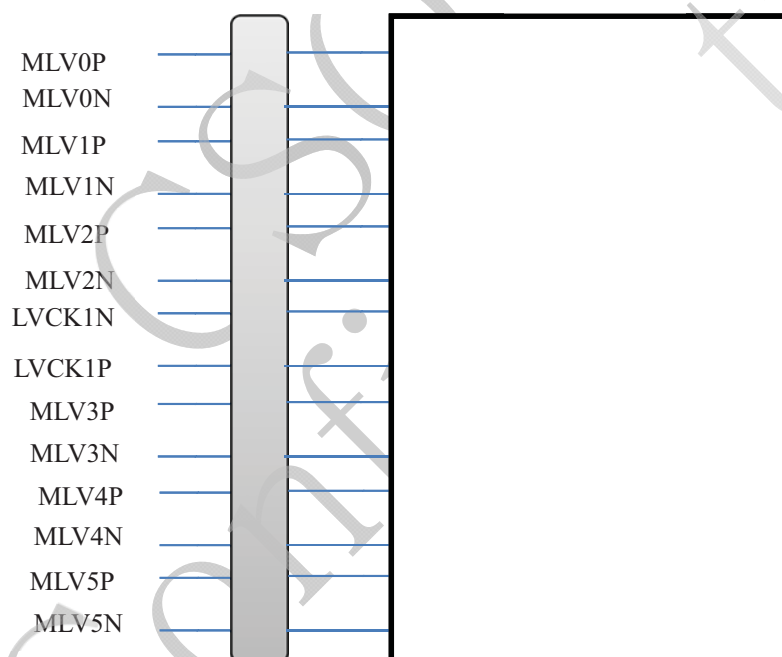

Fig. 4.2 Block diagram of interface

Attention:

- (1) This open cell uses a 64.9 ohms ( $\Omega$ ) resistor between positive and negative lines of each receiver input.
- (2) Mini-LVDS cable impedance shall be 50 ohms per signal line or about 100 ohms per twist-pair line respectively.

### 4.3 Mini-LVDS Data mapping

#### 4.3.1 Cell Structure

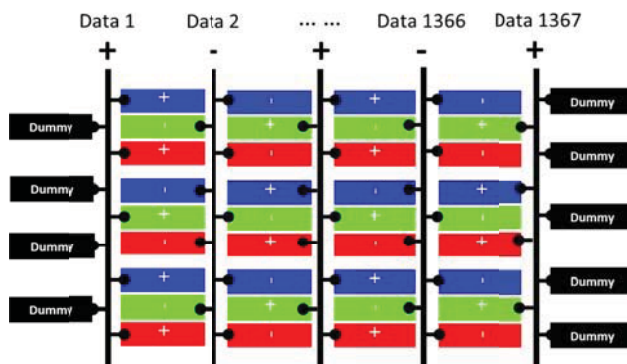

Fig. 4.3 Cell Structure

#### 4.3.2 6 Pair Mode Data Mapping

- a. Reset Signal should be put in MLVOP/N.
- b. MLV0-MLV5 receives data as follows.

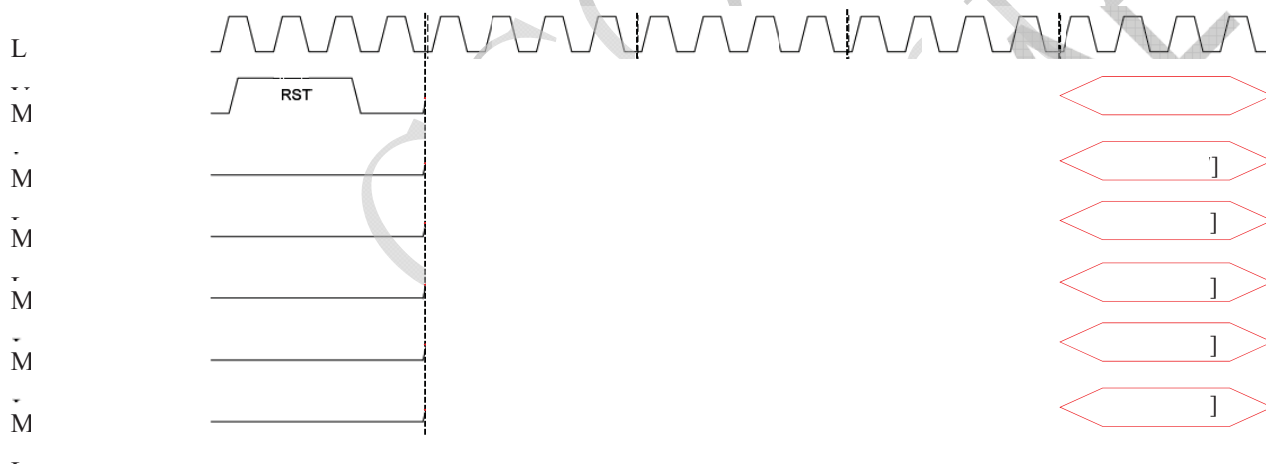
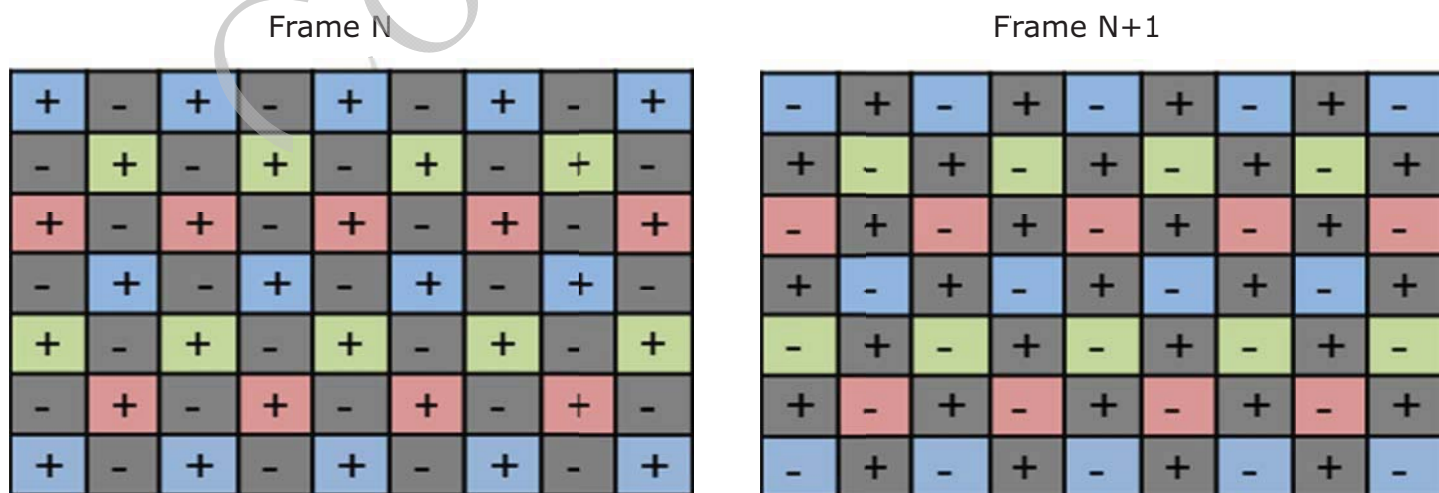

Fig. 4.4 Six pair mode data mapping

### 4.4 Pattern For Vcom Adjustment



## 5. Interface Timing

### 5.1 Timing Table (DE Only Mode)

Signal	Item	Symbol	Min.	Typ.	Max.	Unit	Note
LVDS Clock	Frequency	$F_{CLK}$ ( $= 1 / T_{CLK}$ )	50.0	75.4	80.0	MHz	
Vertical Term	Frame Rate	F	47	60	63	Hz	
	Vertical Frequency	$F_V$	47.0	48.4	60.9	KHz	
	Total	$T_V$	784	806	1015	$T_H$	$T_V = T_{VD} + T_{VB}$
	Display	$T_{VD}$	768			$T_H$	
	Blank	$T_{VB}$	16	38	247	$T_H$	
Horizontal Term	Total	$T_H$	1460	1560	2000	$T_{CLK}$	$T_H = T_{HD} + T_{HB}$
	Display	$T_{HD}$	1366			$T_{CLK}$	
	Blank	$T_{HB}$	94	194	634	$T_{CLK}$	

Attention:

(1) The TFT LCD Open cell is operated in DE only mode, H sync and V sync input signal have no effect on normal operation.

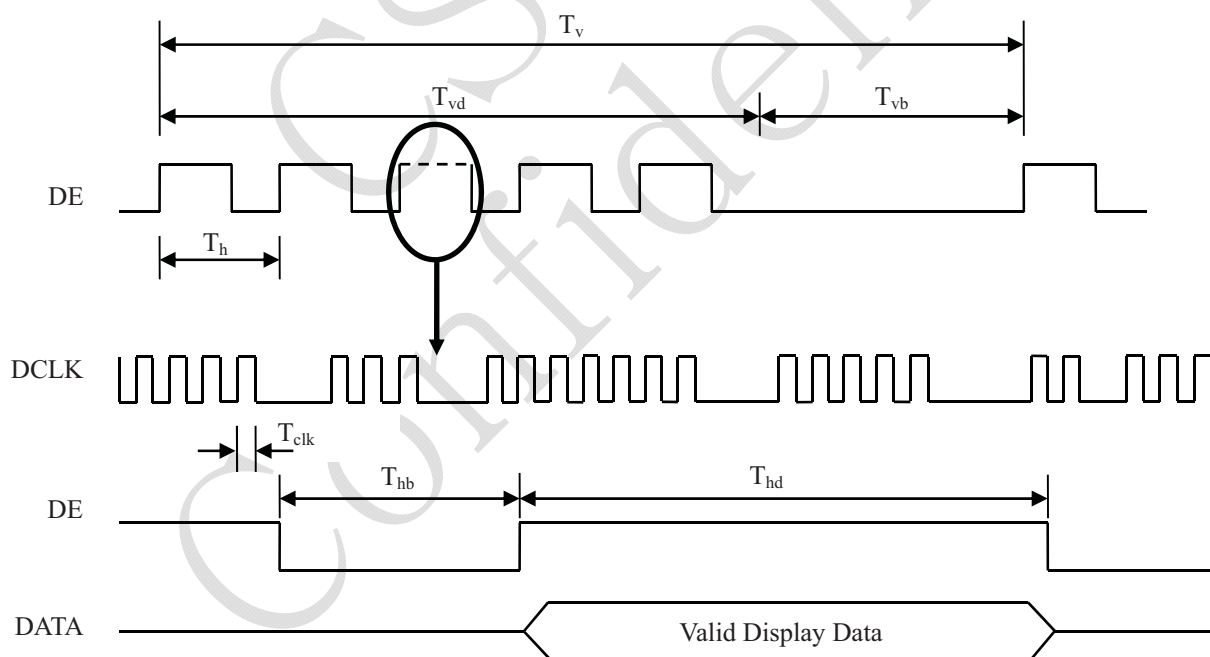

Fig. 5.1 Interface signal timing diagram

## 5.2 Power On/Off Sequence

To prevent a latch-up or DC operation of the Open cell, the power on/off sequence should be as the diagram below.

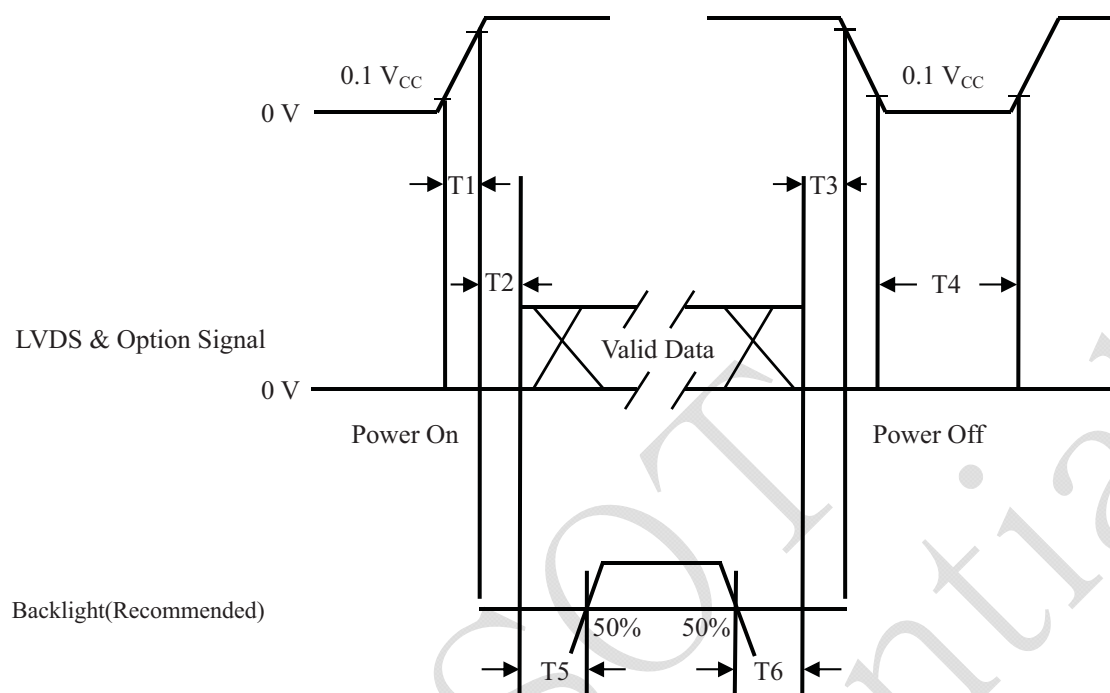

Fig. 5.2 Power on/off sequence

Parameter	Values			Unit
	Min.	Typ.	Max.	
T1	0.5	-	10.0	ms
T2	0	-	-	ms
T3	0	-	-	ms
T4	1000	-	-	ms
T5	500	-	-	ms
T6	100	-	-	ms

### Attention:

- (1) The supply voltage of the external system for the open cell input should follow the definition of V<sub>CC</sub>.
- (2) When the customer's backlight turns on before the LCD operation or the LCD turns off before the backlight turns off, the display may momentarily become abnormal screen.
- (3) In case that V<sub>CC</sub> is in off level, please keep the level of input signals on the low or high impedance. If T2 < 0, that may cause electrical overstress.
- (4) T4 should be measured after the module has been fully discharged between power off and on period.
- (5) Interface signal shall not be kept at high impedance when the power is on.

## 6. Optical Characteristics

### 6.1 Measurement Conditions

The table below is the test condition of optical measurement.

Item	Symbol	Value	Unit
Ambient Temperature	$T_A$	$25 \pm 2$	$^{\circ}\text{C}$
Ambient Humidity	$H_A$	$50 \pm 10$	% RH
Supply Voltage	$V_{CC}$	5	V
Driving Signal	Refer to the typical value in Chapter 3: Electrical Specification		
Vertical Refresh Rate	$F_R$	60	Hz

To avoid abrupt temperature change during optical measurement, it's suggested to warm up the LCD module more than 45 minutes after lighting the backlight and in the windless environment.

To measure the LCD cell, it is suggested to set up the standard measurement system as Fig. 6.1. The measuring area  $S$  should contain at least 500 pixels of the LCD cell as illustrated in Fig.6.2 ( $A$  means the area allocated to one pixel). In this model, for example, the minimum measuring distance  $Z$  is 370 mm when  $\theta$  is 2 degree. Hence, 500 mm is the typical measuring distance. This measuring condition is referred to 301-2H of VESA FPDM 2.0 about viewing distance, angle, and angular field of view definition.

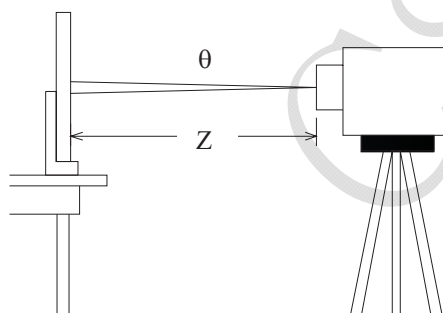

Fig. 6.1 The standard set-up system of measurement

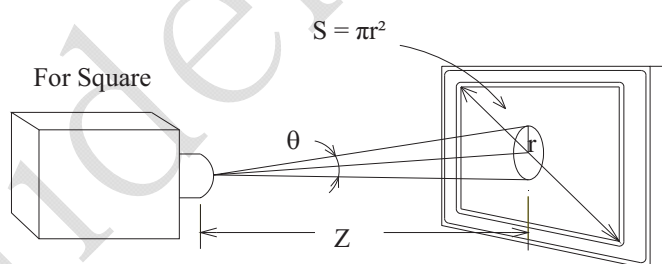

Fig. 6.2 The area  $S$  contains at least 500 pixels to be measured

$$N = \frac{S}{A} \geq 500\text{pixels}$$

$N$  means the actual number of the pixels in the area  $S$ .

## 6.2 Optical Specifications

The table below of optical characteristics is measured by MINOLTA CS2000, MINOLTA CA310, ELDIM OPTI Scope-SA and ELDIM EZ Contrast in dark room. (The optical data in the form is measured by matching the Backlight of MT2751A01-1.)

Item		Symbol	Condition	Min.	Typ.	Max.	Unit	Note		
Static Contrast Ratio		CR	$\theta_H = 0^\circ, \theta_V = 0^\circ$ Normal direction at center point with CSOT's module: MT2751A01-1	2400	3000	-	-	(1) (2)		
Response Time		$T_L$		-	6.5	-	ms	(3)		
Center Transmittance		$T\%$		-	7.2	-	%	(2) (4)		
Color Chromaticity (CIE1931)	Red	$R_X$		Typ. - 0.03	0.610	Typ. + 0.03	-	-	(2) (5)	
		$R_Y$						-		
	Green	$G_X$						0.334		-
		$G_Y$						0.341		-
	Blue	$B_X$						0.608		-
		$B_Y$						0.158		-
	White	$W_X$						0.065		-
		$W_Y$	0.280					-		
Color Gamut		CG	-	62	-	% NTSC				
Viewing Angle	Horizontal	$\theta_{H+}$	$CR \geq 10$	80	89	-	Deg.	(6)		
		$\theta_{H-}$								
	Vertical	$\theta_{V+}$								
		$\theta_{V-}$								

Note:

(1) Definition of static contrast ratio (CR):

It's necessary to switch off all the dynamic and dimming function when measuring the static contrast ratio.

$$\text{Static Contrast Ratio (CR)} = \frac{\text{CR-W}}{\text{CR-D}}$$

CR-W is the luminance measured by LMD (light-measuring device) at the center point of the LCD module with full-screen displaying white. The standard setup of measurement is illustrated in Fig. 6.3; CR-D is the luminance measured by LMD at the center point of the LCD module with full-screen displaying black. The LMD in this item is CS2000.

(2) The LMD in the item could be a spectroradiometer such as (KONICA MINOLTA) CS2000, CS1000(TOPCON), SR-UL2 or the same level spectroradiometer. Other display color analyzer (KONICA MINOLTA) CA210, CA310 or (TOPCON) BM-7 could be involved after being calibrated with a spectroradiometer on each stage of a product.

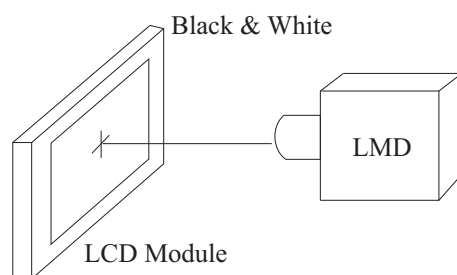
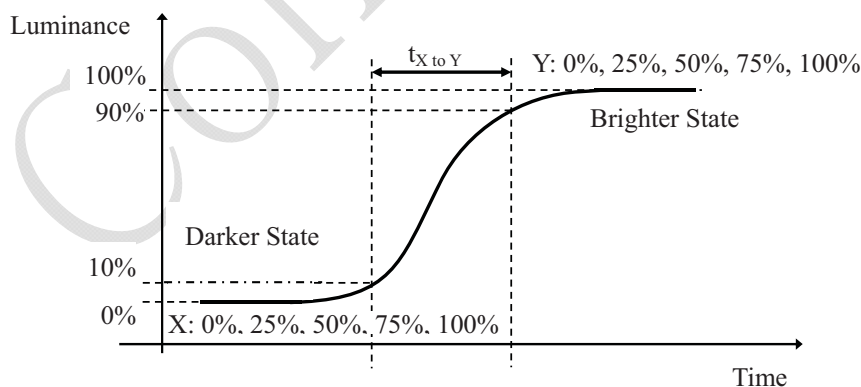

Fig. 6.3 The standard setup of CR measurement

(3) Response time  $T_L$  is defined as the average transition time in the response time matrix. The table below is the response time matrix in which each element  $t_{X \text{ to } Y}$  is the transition time from luminance ratio  $X$  to  $Y$ .  $X$  and  $Y$  are two different luminance ratios among 0%, 25%, 50%, 75%, and 100% luminance. The transition time  $t_{X \text{ to } Y}$  is defined as the time taken from 10% to 90% of the luminance difference between  $X$  and  $Y$  ( $X < Y$ ) as illustrated in Fig.6.4. When  $X > Y$ , the definition of  $t_{X \text{ to } Y}$  is the time taken from 90% to 10% of the luminance difference between  $X$  and  $Y$ . The response time is optimized on refresh rate  $F_r = 60\text{Hz}$ .

Measured Transition Time		Luminance Ratio of Previous Frame				
		0%	25%	50%	75%	100%
Luminance Ratio of Current Frame	0%		$t_{25\% \text{ to } 0\%}$	$t_{50\% \text{ to } 0\%}$	$t_{75\% \text{ to } 0\%}$	$t_{100\% \text{ to } 0\%}$
	25%	$t_{0\% \text{ to } 25\%}$		$t_{50\% \text{ to } 25\%}$	$t_{75\% \text{ to } 25\%}$	$t_{100\% \text{ to } 25\%}$
	50%	$t_{0\% \text{ to } 50\%}$	$t_{25\% \text{ to } 50\%}$		$t_{75\% \text{ to } 50\%}$	$t_{100\% \text{ to } 50\%}$
	75%	$t_{0\% \text{ to } 75\%}$	$t_{25\% \text{ to } 75\%}$	$t_{50\% \text{ to } 75\%}$		$t_{100\% \text{ to } 75\%}$
	100%	$t_{0\% \text{ to } 100\%}$	$t_{25\% \text{ to } 100\%}$	$t_{50\% \text{ to } 100\%}$	$t_{75\% \text{ to } 100\%}$	

$t_{X \text{ to } Y}$  means the transition time from luminance ratio  $X$  to  $Y$ .

Fig. 6.4 The definition of  $t_{X \text{ to } Y}$ 

All the transition time is measured at the center point of the LCD module by ELDIM OPTI Scope-SA.



## (4) Definition of center Transmittance (T%):

The transmittance is measured with full white pattern (Gray 255)

$$\text{Static Contrast Ratio (CR)} = \frac{\text{Luminance of LCD module}}{\text{Luminance of Backlight}}$$

## (5) Definition of color chromaticity:

Each chromaticity coordinates (x, y) are measured in CIE1931 color space when full-screen displaying primary color R, G, B and white. The color gamut is defined as the fraction in percent of the area of the triangle bounded by R, G, B coordinates and the area is defined by NTSC 1953 color standard in the CIE color space. Chromaticity coordinates are measured by CS2000 and the standard setup of measurement is shown in Fig. 6.5.

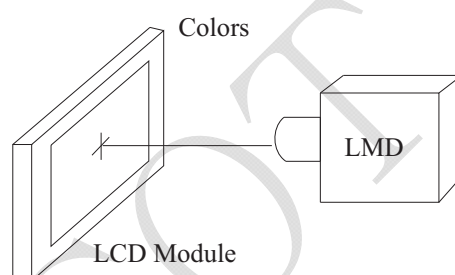

Fig. 6.5 The standard setup of color chromaticity measurement

(6) Definition of viewing angle coordinate system ( $\theta_H$ ,  $\theta_V$ ):

The contrast ratio is measured at the center point of the LCD module. The viewing angles are defined at the angle that the contrast ratio is larger than 10 at four directions relative to the perpendicular direction of the LCD module (two vertical angles: up  $\theta_{V+}$  and down  $\theta_{V-}$ ; and two horizontal angles: right  $\theta_{H+}$  and left  $\theta_{H-}$ ) as illustrated in Fig. 6.6. The contrast ratio is measured by ELDIM EZ Contrast.

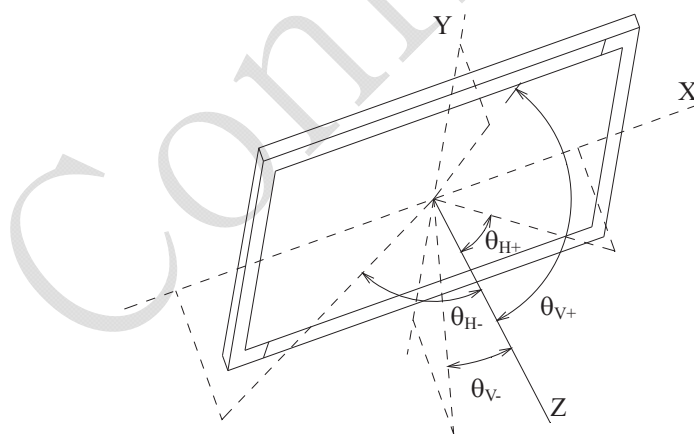
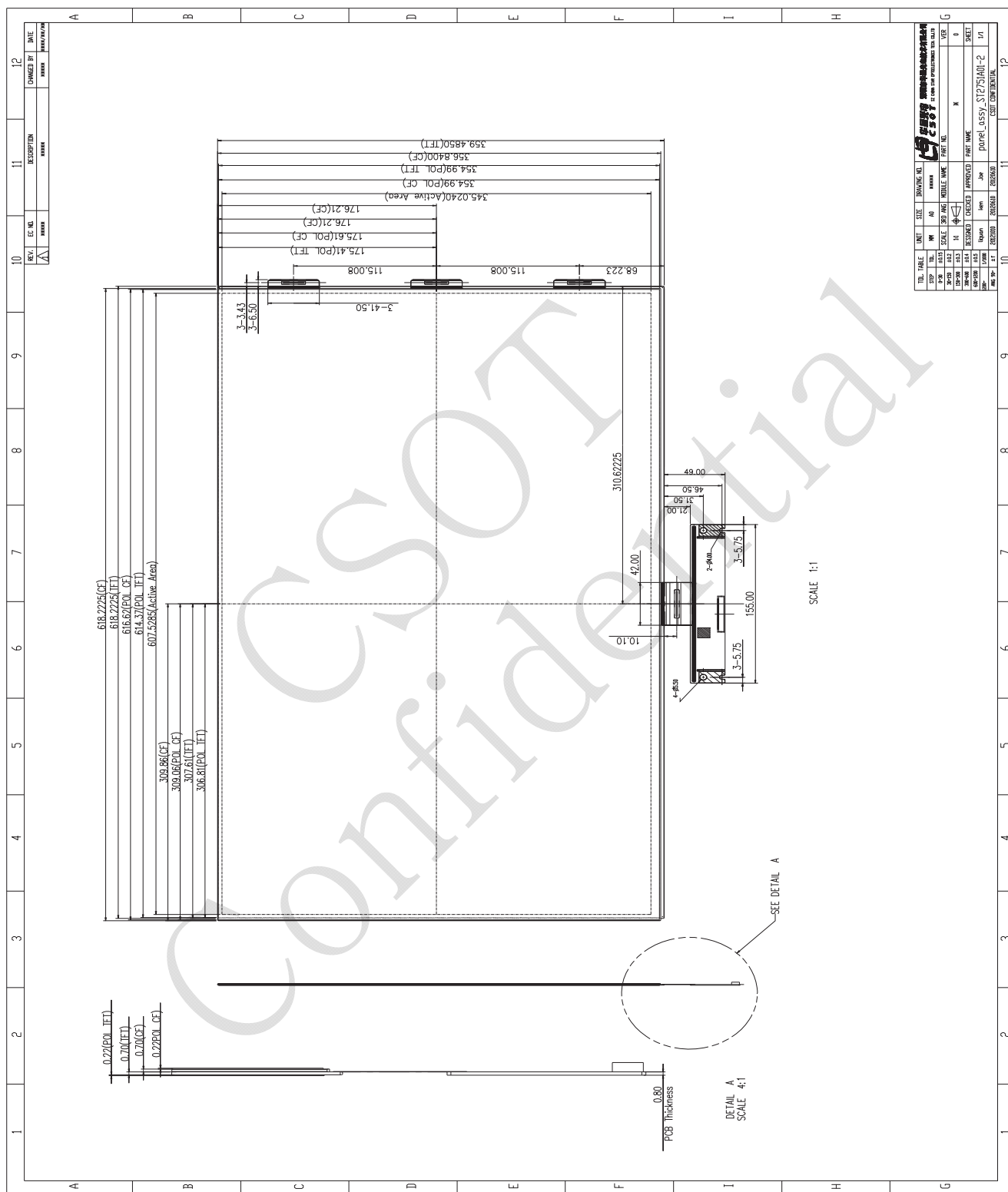

Fig. 6.6 Viewing angle coordination system

## 7. Mechanical Characteristics

### 7.1 Mechanical Specification



## 7.2 Packing

### 7.2.1 Packing Specifications

Item	Specification		
	Quantity	Dimension (mm)	Weight (kg)
Packing Box	9 pcs / box	755.0 (L) x 525.0 (W) x 89.0 (H)	Net Weight: 9.0 (Max.) Gross Weight: 10.5 (Max.)
Pallet	1	1150.0 (L) x 850.0 (W) x 120.0 (H)	Net Weight:5
Stack Layer	17(The top layer is empty.)		
Boxes per Pallet	34 boxes / pallet(Two boxes is empty)		
Pallet after Packing	288 pcs / pallet	1150.0 (L) x 850.0 (W) x 1445.0 (H)	Gross Weight:344.0

### 7.2.2 Packing Method

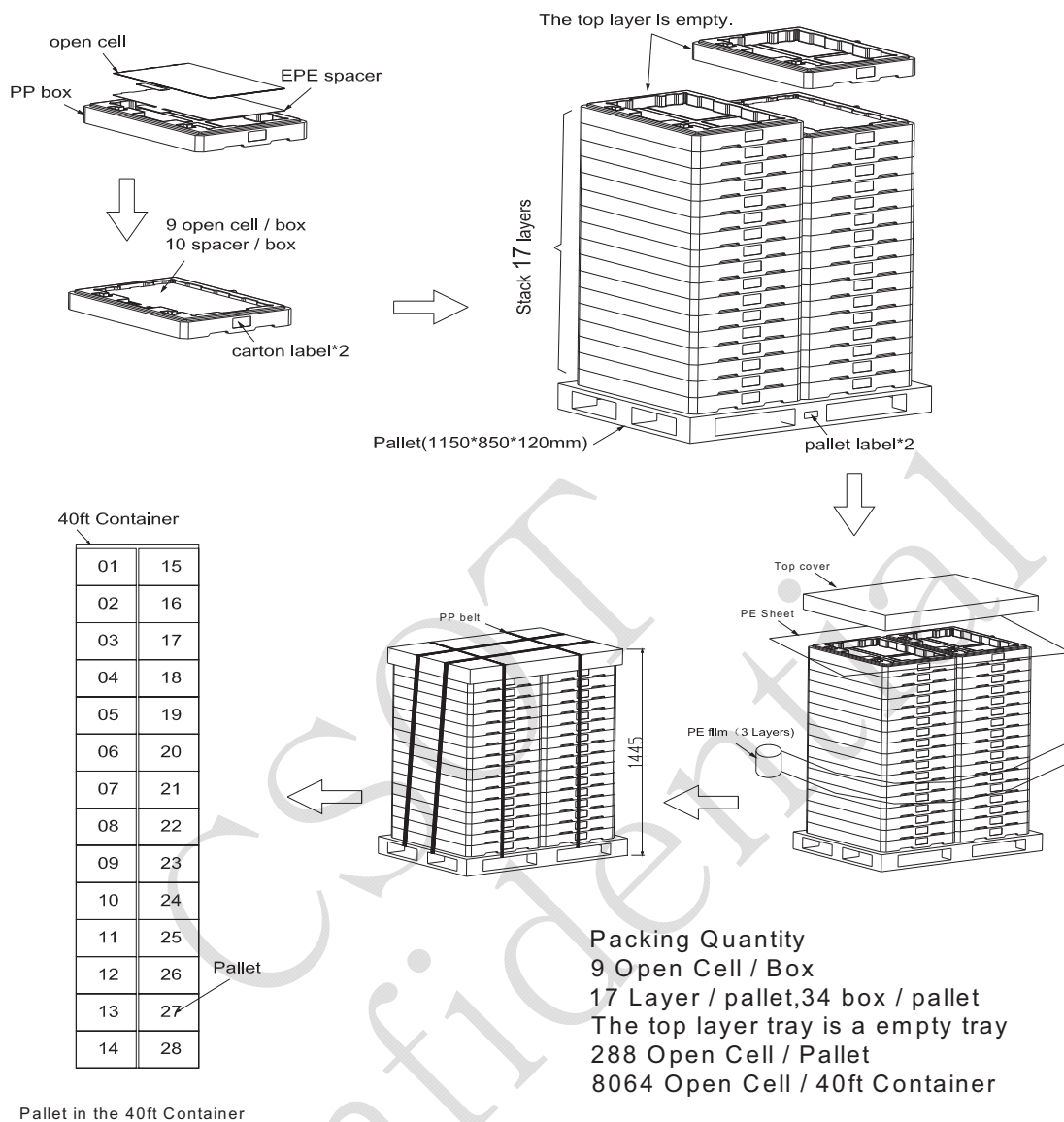

Pallet in the 40ft Container

## 8. Definition of Labels

### 8.1 Open Cell Label

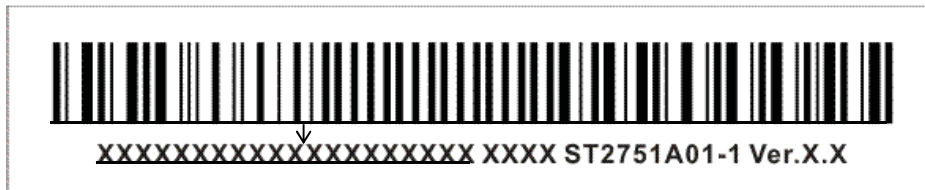

Model Name: ST2751A01-1

Ver.X.X: Version, for example: 0.1, 0.2, ... , 1.1, 1.2, ... , 2.1, 2.2, ...

WC (Week Code): XX XX

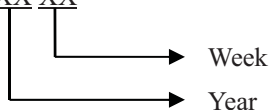

Year: 2010 = 10, 2011 = 11 ... 2020 = 20, 2021 = 21...

Week: 01, 02, 03 ...

Serial Number: XXXXXXXXXXXXXXXX XXXXXXXXXX

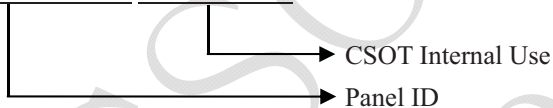

### 8.2 Carton Label



For RoHS compliant products, CSOT will add RoHS for identification.

Serial Number: XXXX XX XXXXXX XXXXXX

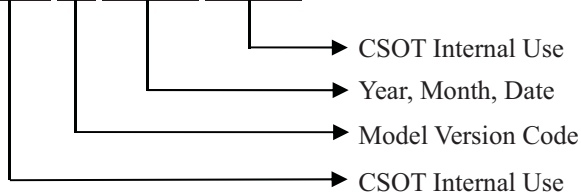

Manufactured Date:

Year: 2010 = 10, 2011 = 11...2020 = 20, 2021 = 21...

Month: 1~9, A~C, for Jan. ~ Dec.

Date: 01~31, for 1st to 31st

Model Version Code: Version of product, for example: 01, 02, 11, 12...

### 8.3 Pallet Label



Serial Number: XXX XX XXX XXXXXX

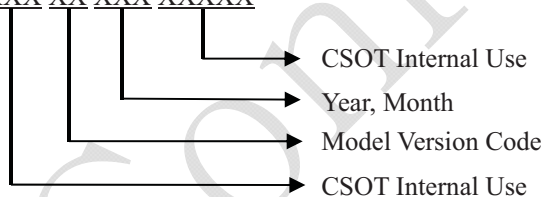

## 9. Precautions

### 9.1 Assembly and Handling Precautions

- (1) Do not apply rough force such as bending or twisting to the open cell during assembly.
- (2) It is recommended to assemble or install a open cell into the user's system in clean working areas. The dust and oil may cause electrical short or damage the polarizer.
- (3) Do not apply pressure or impulse to the open cell to prevent the damage to the open cell.
- (4) Always follow the correct power-on sequence. This can prevent the damage and latch-up to the LSI chips.
- (5) Do not plug in or pull out the interface connector while the open cell is in operation.
- (6) Use soft dry cloth without chemicals for cleaning because the surface of polarizer is very soft and easily be scratched.
- (7) Moisture can easily penetrate into the open cell and may cause the damage during operation.
- (8) High temperature or humidity may deteriorate the performance of the open cell. Please store open cell in the specified storage conditions.
- (9) When ambient temperature is lower than 10 °C, the display quality might be deteriorated. For example, the response time will become slow.

### 9.2 Safety Precautions

- (1) If the liquid crystal material leaks from the panel, it should be kept away from the eyes or mouth. In case of contact with hands, skin or clothes, it has to be washed away thoroughly with soap.
- (2) After the open cell end of life, it is not harmful in case of normal operation and storage.