



MODEL: ST3151A05-9

Ver. 0.1

Date: 19.Mar.2015

Customer's Approval		CSOT	
Signature	Date	Approved By Product Director	Date
		Name: Albert Hu Signature:	
		Reviewed By PM Manager	Date
		Name: Xiuyi Wang Signature:	
		Reviewed By Project Leader	Date
		Name: Joseph Hsiao Signature:	
		Reviewed By PM	Date
		Name: Lin Xu Signature:	

Contents

1. General Description	4
1.1 Product Features	4
1.2 Overview	4
1.3 General Information	4
2. Absolute Maximum Ratings	5
2.1 Absolute Maximum Ratings (TA = 25 ± 2 °C)	5
2.2 Environment Requirement (Based on CSOT Module MT3151A05-1).....	5
2.3 Absolute ratings of Environment (Open Cell)	5
3. Electrical Specification	6
3.1 Open cell Power Consumption (TA = 25 ± 2 °C)	6
3.2 LVDS Characteristics	7
4. Input Terminal Pin Assignment.....	8
4.1 Interface pin assignment.....	8
4.2 Block Diagram of Interface	9
4.3 LVDS Interface.....	9
4.3.1 VESA Format (SELLVDS = L or Open).....	9
4.3.2 JEIDA Format (SELLVDS = H)	10
4.4 Pattern FOR Vcom Adjustment.....	10
5. Interface Timing.....	11
5.1 Timing Table (DE Only Mode)	11
5.2 Power On/Off Sequence	13
6. Optical Characteristics	14
6.1 Measurement Conditions.....	14
6.2 Optical Specifications	15
7. Mechanical Characteristics	18
7.1 Mechanical Specification	18
7.2 Packing.....	19
7.2.1 Packing Specifications.....	19
7.2.2 Packing Method	19
8. Definition of Labels	20
8.1 Open Cell Label	20
8.2 Carton Label.....	20
8.3 Pallet Label.....	21
9. Precautions.....	22
9.1 Assembly and Handling Precautions	22
9.2 Safety Precautions	22

Revision History

Version	Date	Page (New)	Section	Description	Revision by
Ver. 0.1	19.Mar.2015	All	All	Preliminary Specification was First Issued.	Ying.Zou

CSOT
Confidential
液晶仓库
www.gotolcd.com

1. General Description

1.1 Product Features

- **HD Resolution (1366 x 768)**
- **High Contrast Ratio: 3000:1**
- **Fast Response Time**
- **Ultra Wide Viewing Angle: 178° (H)/178° (V) (CR ≥ 10)**
- **DE (Data Enable) Mode**
- **LVDS (Low Voltage Differential Signaling) Interface**

1.2 Overview

ST3151A05-9 is a diagonal 31.5" color active matrix LCD open cell with 1ch-LVDS interface. This open cell is a transmissive type display operating in the normally black mode. It supports 1366 x 768 HD resolution and can display up to 16.7M colors (8-bit). Each pixel is divided into Red, Green and Blue sub-pixels which are arranged in horizontal stripe. There is no backlight built-in.

This open cell dedicates for LCD TV products and provides excellent performance which includes high transmittance, ultra wide viewing angle and high color depth. CSOT open cell comply with RoHS for identification.

1.3 General Information

Item	Specification	Unit	Note
Active Area	697.685 (H) x 392.256 (V)	mm	
Cell Size	715.035 (H) x 410.570 (V) x 1.500 (D)	mm	
Driving Scheme	a-Si TFT Active Matrix	-	
Number of Pixels	1366 x 768	pixel	
Pixel Pitch (Sub Pixel)	0.17025 (H) x 0.51075 (V)	mm	
Pixel Arrangement	RGB Horizontal Stripe	-	
Display Colors	16.7 M	color	8-bit
Display Mode	Transmissive Mode, Normally Black	-	
Glass thickness (Array / CF)	0.5 / 0.5	mm	
Color Chromaticity	R = 0.615, 0.337 G = 0.299, 0.568 B = 0.147, 0.069 W = 0.260, 0.282		Typical value measured at CSOT's module: MT3151A05-1
Contrast Ratio	3000:1 (Typ.)		
Cell Transmittance	7.16% (Typ.)	%	
View Angle (CR>10)	+ 89 / - 89 (H), + 89 / - 89 (V) (Typ.)		
Polarizer (CF side)	Low Haze 2%		
Polarizer (TFT side)	Hard Coating (3H)		

2. Absolute Maximum Ratings

2.1 Absolute Maximum Ratings ($T_A = 25 \pm 2 \text{ }^\circ\text{C}$)

The followings are maximum values which, if exceeded, may cause damage to the unit.

Item	Symbol	Value		Unit
		Min.	Max.	
Power Supply Voltage	V_{CC}	- 0.3	13.5	V
Input Signal Voltage	V_{IN}	- 0.3	3.6	V

2.2 Environment Requirement (Based on CSOT Module MT3151A05-1)

(1) Temperature and relative humidity range are shown as below.

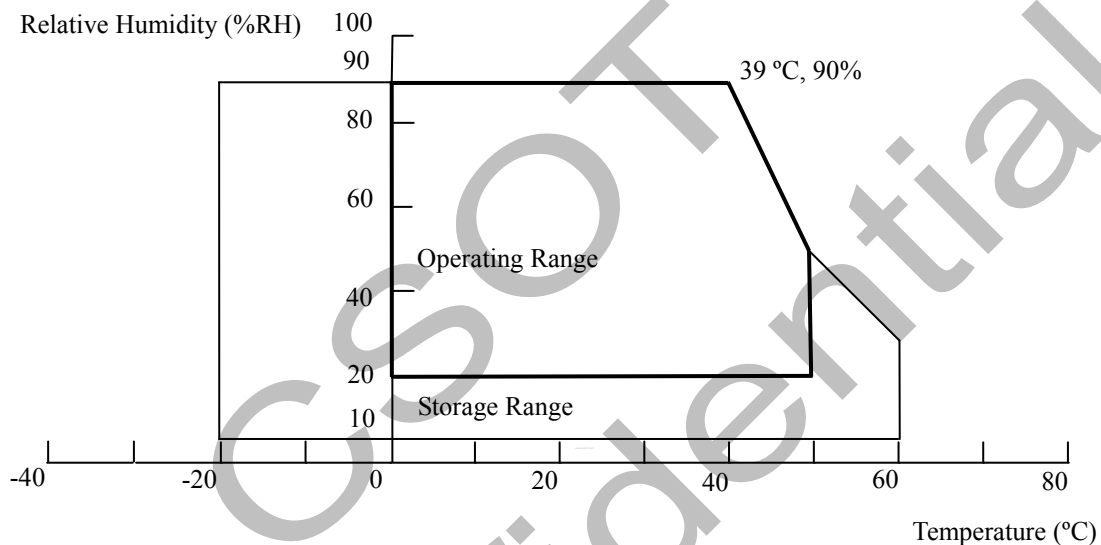

Fig. 2.1 Operating and storage environment

- 90%RH maximum ($T_A < 39$ $^\circ\text{C}$).
- Wet-bulb temperature should be 39 $^\circ\text{C}$ maximum ($T_A > 39$ $^\circ\text{C}$).
- No condensation.

(2) The storage temperature is between -20 $^\circ\text{C}$ to 60 $^\circ\text{C}$, and the operating ambient temperature is between 0 $^\circ\text{C}$ to 50 $^\circ\text{C}$.

The maximum operating temperature is based on the test condition that the surface temperature of the display area is less than or equal to 65 $^\circ\text{C}$ with the LCD module in a temperature-controlled chamber alone. Thermal management should be considered in final product design to prevent the surface temperature of the display area from being over 65 $^\circ\text{C}$. The range of operating temperature may degrade in case of improper thermal management in the end product design.

(3) The rating of environment is based on the LCD module. Leave the LCD cell alone; this environment condition can't be guaranteed.

Except for the LCD cell, the customer has to consider the ability of other parts of the LCD module and the LCD module process.

2.3 Absolute Ratings of Environment (Open Cell)

When storing an open cell as spares for a long time, please follow the precaution instructions:

- Do not store the module in high temperature and high humidity for a long time. It is highly recommended to store the module with temperature from 20 $^\circ\text{C}$ to 30 $^\circ\text{C}$ in normal humidity (50 ± 10 %RH) with shipping package.
- The open cell should be kept within one month shelf life.

3. Electrical Specification

3.1 Open Cell Power Consumption (TA = 25 ± 2 °C)

Parameter		Symbol	Value			Unit	Note
			Min.	Typ.	Max.		
Power Supply Voltage		V_{CC}	10.8	12.0	13.2	V	(1)
Rush Current		I_{RUSH}	-	-	3	A	(2)
Power Supply Current	White Pattern	I_{CC}	-	0.16	0.23	A	(3)
	Vertical Stripe	I_{CC}	-	0.24	0.34	A	
	Black Pattern	I_{CC}	-	0.16	0.24	A	

Note:

(1) The ripple voltage should be controlled less than 10% of V_{CC} .

(2) Measurement condition: V_{CC} rising time = 470 μ s.

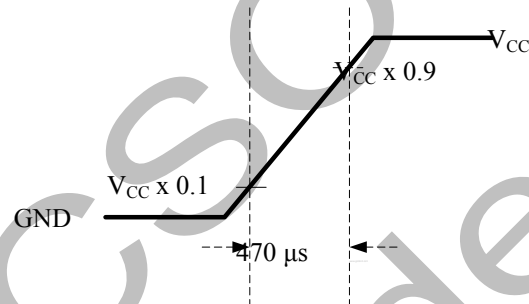

Fig. 3.1 V_{CC} rising time condition

(3) Measurement condition: $V_{CC} = 12$ V, $T_a = 25 \pm 2$ °C, $F = 60$ Hz. The test patterns are shown as below.

A. White Pattern



B. Vertical Stripe Pattern

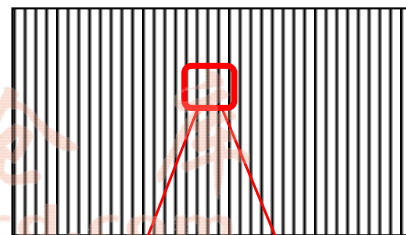

C. Black Pattern



Fig. 3.2 Test patterns

3.2 LVDS Characteristics

Parameter		Symbol	Value			Unit	Note
			Min.	Typ.	Max.		
LVDS Interface	Differential Input High Threshold Voltage	V_{TH}	+ 100	-	-	mV	(1)
	Differential Input Low Threshold Voltage	V_{TL}	-	-	- 100	mV	
	Common Input Voltage	V_{CM}	1.0	1.2	1.4	V	
	Differential Input Voltage	$ V_{ID} $	100	-	600	mV	
	Terminating Resistor	R_T	-	100	-	ohm	
CMOS Interface	Input High Threshold Voltage	V_{IH}	2.7	-	3.3	V	
	Input Low Threshold Voltage	V_{IL}	0	-	0.6	V	

Note:

(1) The LVDS input signal has been defined as follows:

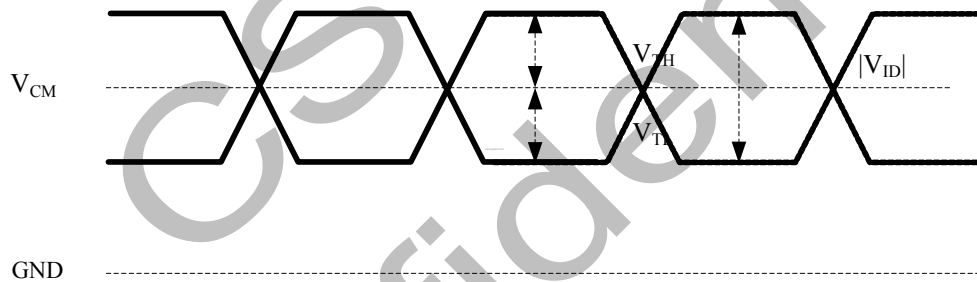

Fig. 3.3 LVDS input signal

液晶仓库
www.gotolcd.com

4. Input Terminal Pin Assignment

4.1 Interface Pin Assignment

CN1: 300B30-0000RA-M4 (STARCONN) or equivalent (see Note (1))

Pin No.	Symbol	Description	Note
1	V _{CC}	Power Supply ,+ 12 V DC Regulated	
2	V _{CC}	Power Supply ,+ 12 V DC Regulated	
3	V _{CC}	Power Supply ,+ 12 V DC Regulated	
4	V _{CC}	Power Supply ,+ 12 V DC Regulated	
5	GND	Ground	
6	GND	Ground	
7	GND	Ground	
8	GND	Ground	
9	LVDS SEL	LVDS Data Format Selection	(2)
10	NC	For CSOT Users Only	
11	GND	Ground	
12	LV1N0	1st Channel LVDS Data Input (0-)	
13	LV1P0	1st Channel LVDS Data Input (0+)	
14	GND	Ground	
15	LV1N1	1st Channel LVDS Data Input (1-)	
16	LV1P1	1st Channel LVDS Data Input (1+)	
17	GND	Ground	
18	LV1N2	1st Channel LVDS Data Input (2-)	
19	LV1P2	1st Channel LVDS Data Input (2+)	
20	GND	Ground	
21	LVCK1N	1st Channel LVDS Clock Input (-)	
22	LVCK1P	1st Channel LVDS Clock Input (+)	
23	GND	Ground	
24	LV1N3	1st Channel LVDS Data Input (3-)	
25	LV1P3	1st Channel LVDS Data Input (3+)	
26	GND	Ground	
27	WP	For DVcom Write, H/open: read only; L: read & write	
28	SDA	For DVcom Write	
29	SCL	For DVcom Write	
30	GND	Ground	

Note:

(1) The direction of pin assignment is shown as below:

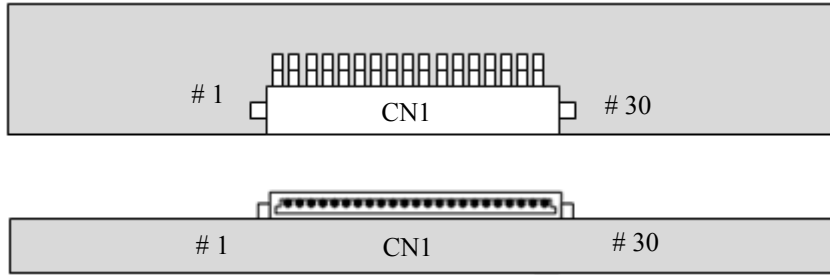

Fig. 4.1 LVDS direction sketch map

(2) High: connect to +3.3 V → JEIDA format; Low: connect to GND or Open → VESA format.

(3) For CSOT internal only, please let it open.

4.2 Block Diagram of Interface

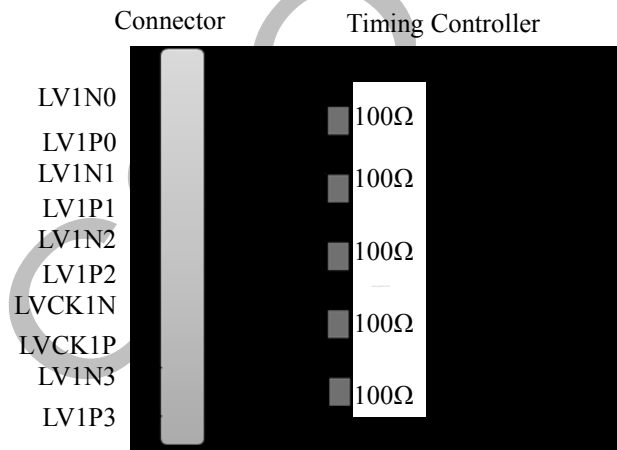

Fig. 4.2 Block diagram of interface

Attention:

(1) This open cell uses a 100 ohms (Ω) resistor between positive and negative lines of each receiver input.

(2) LVDS cable impedance shall be 50 ohms per signal line or about 100 ohms per twist-pair line respectively.

4.3 LVDS Interface

4.3.1 VESA Format (SELLVDS = L or Open)

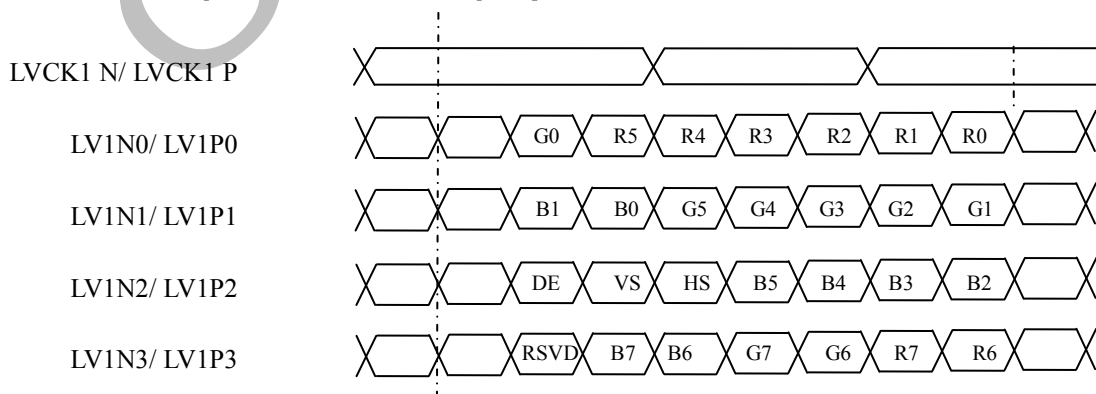

4.3.2 JEIDA Format (SELLVDS = H)

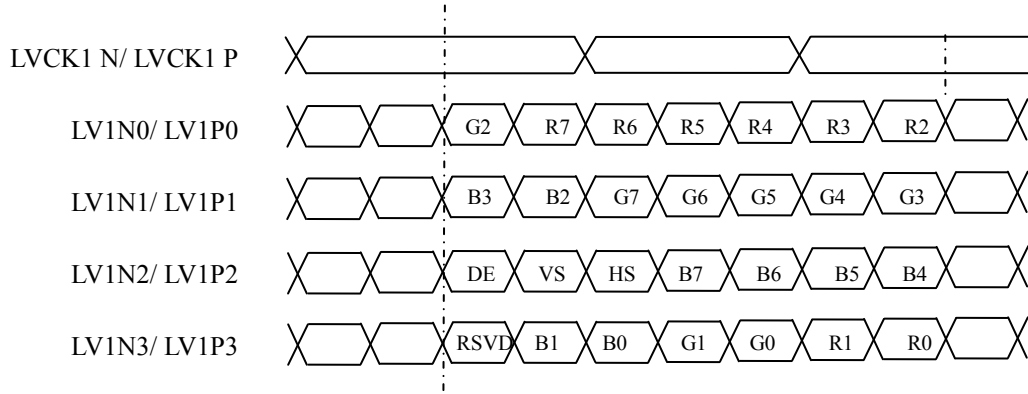

4.4 Pattern for Vcom Adjustment

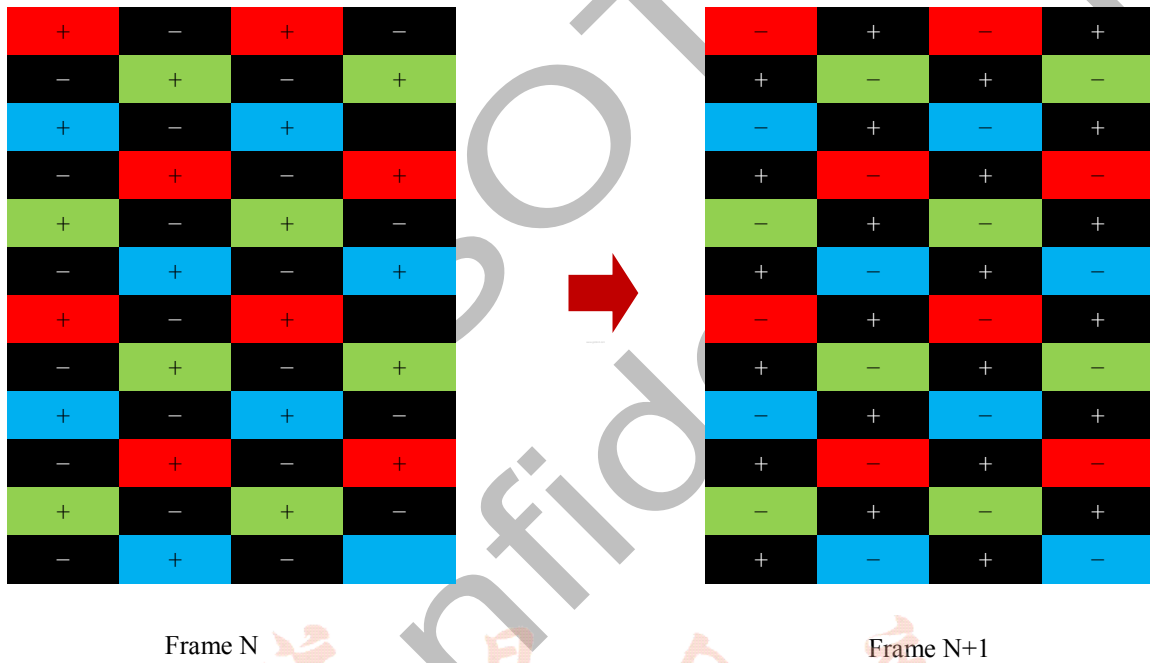

Fig. 4.3 Pattern for Vcom adjustment

5. Interface Timing

5.1 Timing Table (DE Only Mode)

Signal	Item	Symbol	Min.	Typ.	Max.	Unit	Note
LVDS Clock	Frequency	F_{CLKIN} ($= 1 / T_{CLK}$)	50.0	75.4	85.0	MHz	(2)
	Input cycle to cycle jitter	TRCL	—	—	200	ps	(3)
	Spread spectrum modulation range	F_{CLKIN_MOD}	$F_{CLKIN}-2\%$	—	$F_{CLKIN}+2\%$	MHz	(4)
	Spread spectrum modulation frequency	F_{SSM}			200	KHz	
LVDS Receiver Data	Receiver Skew Margin	T_{RSM}	-400		400	ps	(5)
Vertical Term	Frame Rate	F	47	60	63	Hz	
	Vertical Frequency	F_V	47.0	48.4	60.9	KHz	
	Total	T_V	784	806	1015	T_H	$T_V = T_{VD} + T_{VB}$
	Display	T_{VD}	768				
	Blank	T_{VB}	16	38	247	T_H	
Horizontal Term	Total	T_H	1460	1560	2000	T_{CLK}	$T_H = T_{HD} + T_{HB}$
	Display	T_{HD}	1366				
	Blank	T_{HB}	94	194	634	T_{CLK}	

Attention:

(1) The TFT LCD open cell is operated in DE only mode, H sync and V sync input signal have no effect on normal operation.

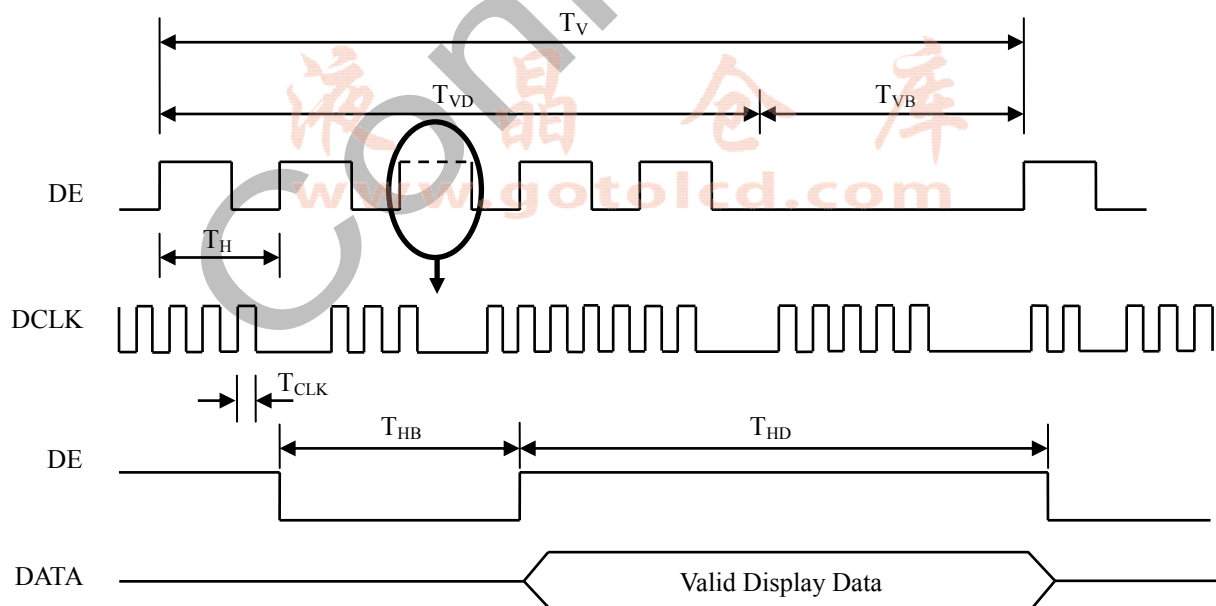

Fig. 5.1 Interface signal timing diagram

(2) Please make sure the range of pixel clock follows the following equations:

$$F_{\text{CLKIN}}(\text{max}) \geq F(\text{max}) \times T_V \times T_H$$

$$F(\text{min}) \times T_V \times T_H \geq F_{\text{CLKIN}}(\text{min})$$

(3) The input clock cycle-to-cycle jitter is defined as the following figure. $T_{\text{RCL}} = |T_1 - T_2|$

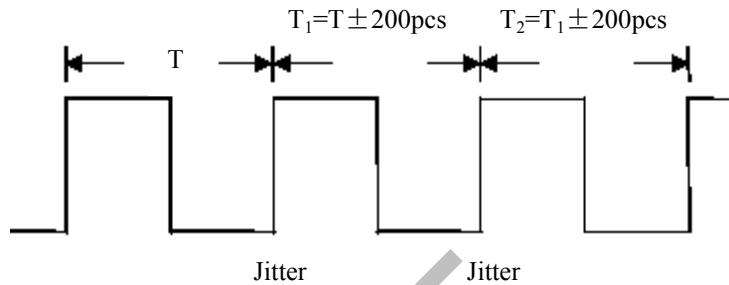

Fig. 5.2 The definition of the clock cycle-to-cycle jitter

(4) The SSCG (Spread Spectrum Clock Generator) is defined as the following figure.

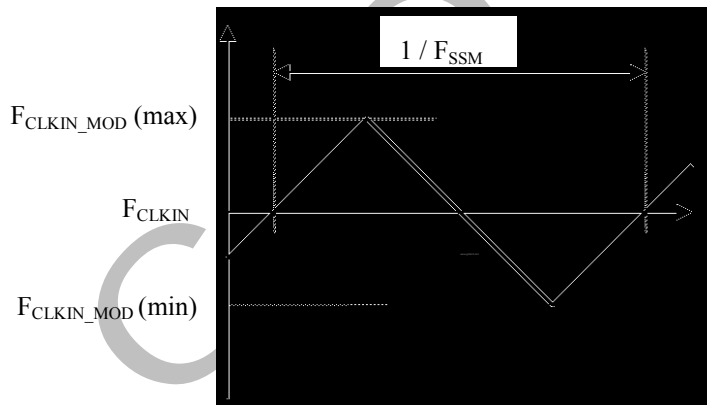

Fig. 5.3 The definition of SSCG

(5) The LVDS timing diagram and setup/hold time is defined and showed as the following figure.



Fig. 5.4 The LVDS timing diagram and the definition of setup/hold time

5.2 Power on/off Sequence

To prevent a latch-up or DC operation of the open cell, the power on/off sequence should be as the diagram below.

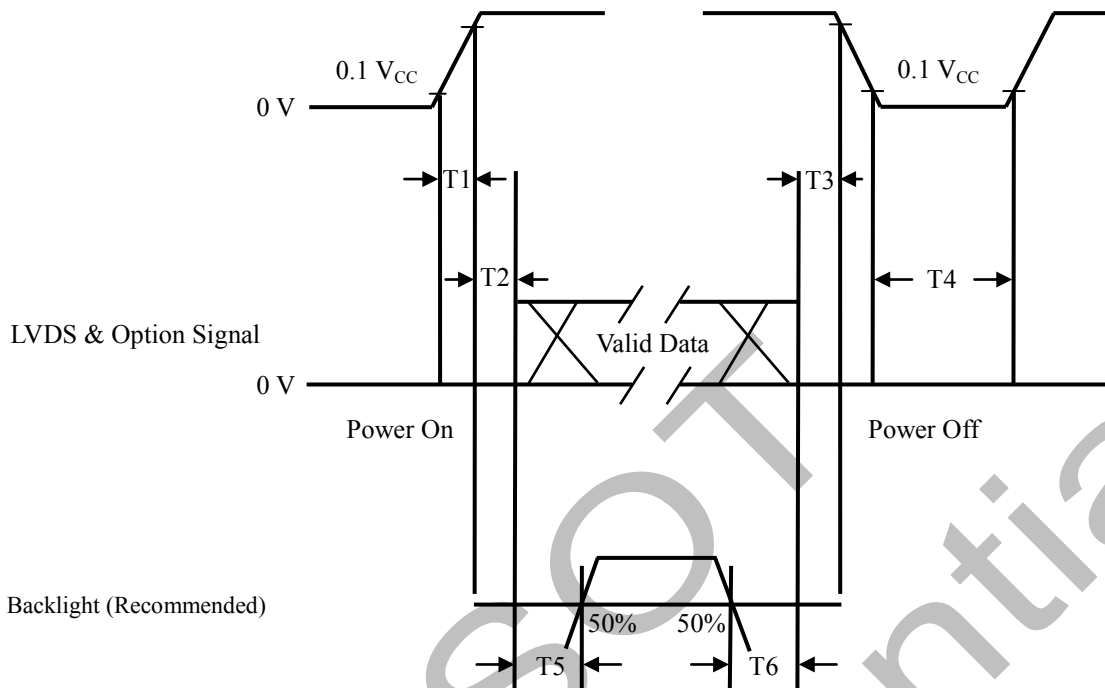

Fig. 5.2 Power on / off Sequence

Parameter	Values			Unit
	Min.	Typ.	Max.	
T1	0.5	-	10.0	ms
T2	0	-	50	ms
T3	0	-	50	ms
T4	1000	-	-	ms
T5	500	-	-	ms
T6	100	-	-	ms

Attention:

- (1) The supply voltage of the external system for the open cell input should follow the definition of V_{CC} .
- (2) When the customer's backlight turns on before the LCD operation or the LCD turns off before the backlight turns off, the display may momentarily become abnormal screen.
- (3) In case that V_{CC} is in off level, please keep the level of input signals on the low or high impedance. If $T2 < 0$, that may cause electrical overstress.
- (4) T4 should be measured after the module has been fully discharged between power off and on period.
- (5) Interface signal shall not be kept at high impedance when the power is on.

6. Optical Characteristics

6.1 Measurement Conditions

The table below is the test condition of optical measurement.

Item	Symbol	Value	Unit
Ambient Temperature	T_A	25 ± 2	$^{\circ}\text{C}$
Ambient Humidity	H_A	50 ± 10	% RH
Supply Voltage	V_{CC}	12	V
Driving Signal	Refer to the typical value in Chapter 3: Electrical Specification		
Vertical Refresh Rate	F_R	60	Hz

To avoid abrupt temperature change during optical measurement, it's suggested to warm up the LCD module more than 45 minutes after lighting the backlight and in the windless environment.

To measure the LCD cell, it is suggested to set up the standard measurement system as Fig. 6.1. The measuring area S should contain at least 500 pixels of the LCD cell as illustrated in Fig.6.2 (A means the area allocated to one pixel). In this model, for example, the minimum measuring distance Z is 370 mm when θ is 2 degree. Hence, 500 mm is the typical measuring distance. This measuring condition is referred to 301-2H of VESA FPDM 2.0 about viewing distance, angle, and angular field of view definition.

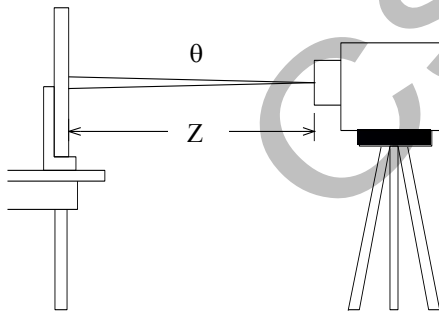

Fig. 6.1 The standard set-up system of measurement

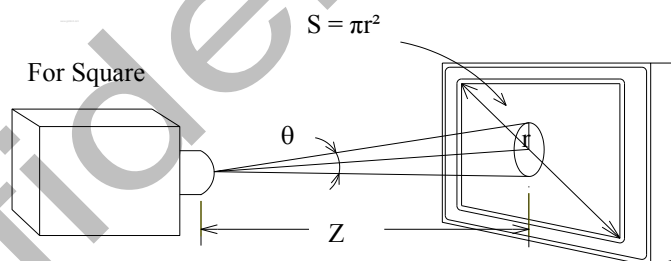

Fig. 6.2 The area S contains at least 500 pixels to be measured

$$N = \frac{S}{A} \geq 500\text{pixels}$$

N means the actual number of the pixels in the area S .

6.2 Optical Specifications

The table below of optical characteristics is measured by MINOLTA CS2000, MINOLTA CA310, ELDIM OPTI Scope-SA and ELDIM EZ contrast in dark room. (The optical data in the form is measured by matching the backlight of MT3151A05-1.)

Item		Symbol	Condition	Min.	Typ.	Max.	Unit	Note
Static Contrast Ratio		CR		2400	3000	-	-	(1) (2)
Response Time		T _L		-	6.5	-	ms	(3)
Center Transmittance		T%		-	7.16	-	%	(2) (4)
Color Chromaticity (CIE1931)	Red	R _X	θ _H = 0°, θ _V = 0° Normal direction at center point with CSOT's module: MT3151A05-1	Typ. - 0.03	0.615	Typ. + 0.03	-	(2) (5)
		R _Y			0.337		-	
	Green	G _X			0.299		-	
		G _Y			0.568		-	
	Blue	B _X			0.147		-	
		B _Y			0.069		-	
	White	W _X			0.260		-	
		W _Y			0.282		-	
Color Gamut		CG		-	62	-	% NTSC	
Viewing Angle	Horizontal	θ _{H+}	CR ≥ 10	80	89	-	Deg.	(6)
		θ _{H-}		80	89	-		
	Vertical	θ _{V+}		80	89	-		
		θ _{V-}		80	89	-		

Note:

(1) Definition of static contrast ratio (CR):

It's necessary to switch off all the dynamic and dimming function when measuring the static contrast ratio.

$$\text{Static Contrast Ratio (CR)} = \frac{\text{CR-W}}{\text{CR-D}}$$

CR-W is the luminance measured by LMD (light-measuring device) at the center point of the LCD module with full-screen displaying white. The standard setup of measurement is illustrated in Fig. 6.3; CR-D is the luminance measured by LMD at the center point of the LCD module with full-screen displaying black. The LMD in this item is CS2000.

(2) The LMD in the item could be a spectroradiometer such as (KONICA MINOLTA) CS2000, CS1000(TOPCON), SR-UL2 or the same level spectroradiometer. Other display color analyzer (KONICA MINOLTA) CA210, CA310 or (TOPCON) BM-7 could be involved after being calibrated with a spectroradiometer on each stage of a product.

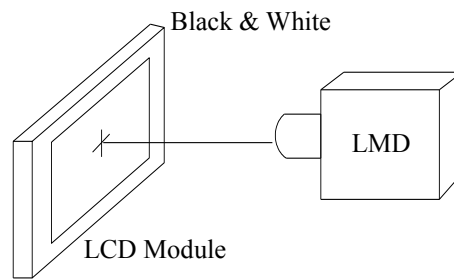
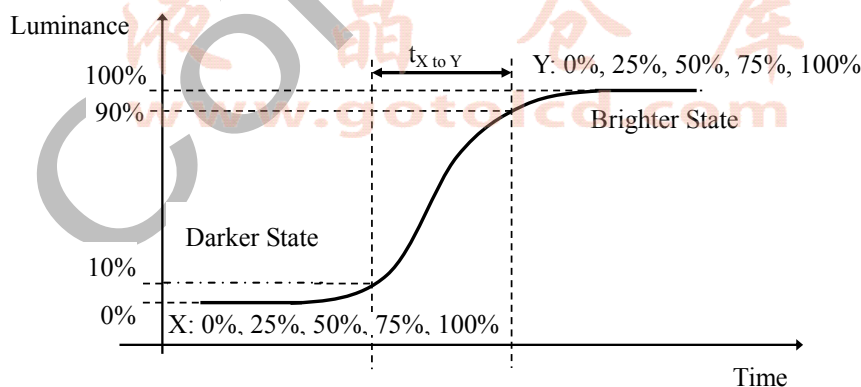

Fig. 6.3 The standard setup of CR measurement

(3) Response time T_L is defined as the average transition time in the response time matrix. The table below is the response time matrix in which each element $t_{X \text{ to } Y}$ is the transition time from luminance ratio X to Y . X and Y are two different luminance ratios among 0%, 25%, 50%, 75%, and 100% luminance. The transition time $t_{X \text{ to } Y}$ is defined as the time taken from 10% to 90% of the luminance difference between X and Y ($X < Y$) as illustrated in Fig.6.4. When $X > Y$, the definition of $t_{X \text{ to } Y}$ is the time taken from 90% to 10% of the luminance difference between X and Y . The response time is optimized on refresh rate $F_r = 60\text{Hz}$.

Measured Transition Time		Luminance Ratio of Previous Frame				
		0%	25%	50%	75%	100%
Luminance Ratio of Current Frame	0%		$t_{25\% \text{ to } 0\%}$	$t_{50\% \text{ to } 0\%}$	$t_{75\% \text{ to } 0\%}$	$t_{100\% \text{ to } 0\%}$
	25%	$t_{0\% \text{ to } 25\%}$		$t_{50\% \text{ to } 25\%}$	$t_{75\% \text{ to } 25\%}$	$t_{100\% \text{ to } 25\%}$
	50%	$t_{0\% \text{ to } 50\%}$	$t_{25\% \text{ to } 50\%}$		$t_{75\% \text{ to } 50\%}$	$t_{100\% \text{ to } 50\%}$
	75%	$t_{0\% \text{ to } 75\%}$	$t_{25\% \text{ to } 75\%}$	$t_{50\% \text{ to } 75\%}$		$t_{100\% \text{ to } 75\%}$
	100%	$t_{0\% \text{ to } 100\%}$	$t_{25\% \text{ to } 100\%}$	$t_{50\% \text{ to } 100\%}$	$t_{75\% \text{ to } 100\%}$	

$t_{X \text{ to } Y}$ means the transition time from luminance ratio X to Y .

Fig. 6.4 The definition of $t_{X \text{ to } Y}$

All the transition time is measured at the center point of the LCD module by ELDIM OPTI Scope-SA.

(4) Definition of center Transmittance (T%):

The transmittance is measured with full white pattern (Gray 255)

$$\text{Center Transmittance (T\%)} = \frac{\text{Luminance of LCD module}}{\text{Luminance of Backlight}}$$

(5) Definition of color chromaticity:

Each chromaticity coordinates (x, y) are measured in CIE1931 color space when full-screen displaying primary color R, G, B and white. The color gamut is defined as the fraction in percent of the area of the triangle bounded by R, G, B coordinates and the area is defined by NTSC 1953 color standard in the CIE color space. Chromaticity coordinates are measured by CS2000 and the standard setup of measurement is shown in Fig. 6.5.

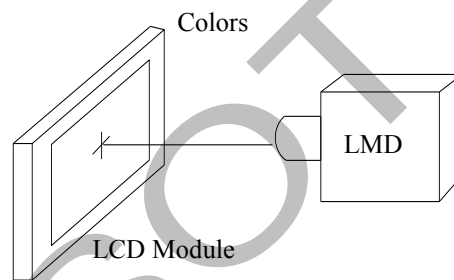

Fig. 6.5 The standard setup of color chromaticity measurement

(6) Definition of viewing angle coordinate system (θ_H , θ_V):

The contrast ratio is measured at the center point of the LCD module. The viewing angles are defined at the angle that the contrast ratio is larger than 10 at four directions relative to the perpendicular direction of the LCD module (two vertical angles: up θ_{V+} and down θ_{V-} ; and two horizontal angles: right θ_{H+} and left θ_{H-}) as illustrated in Fig. 6.6. The contrast ratio is measured by ELDIM EZ Contrast.

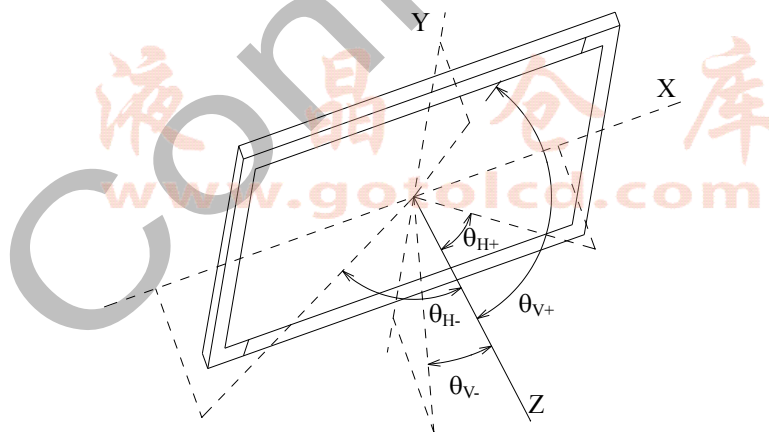
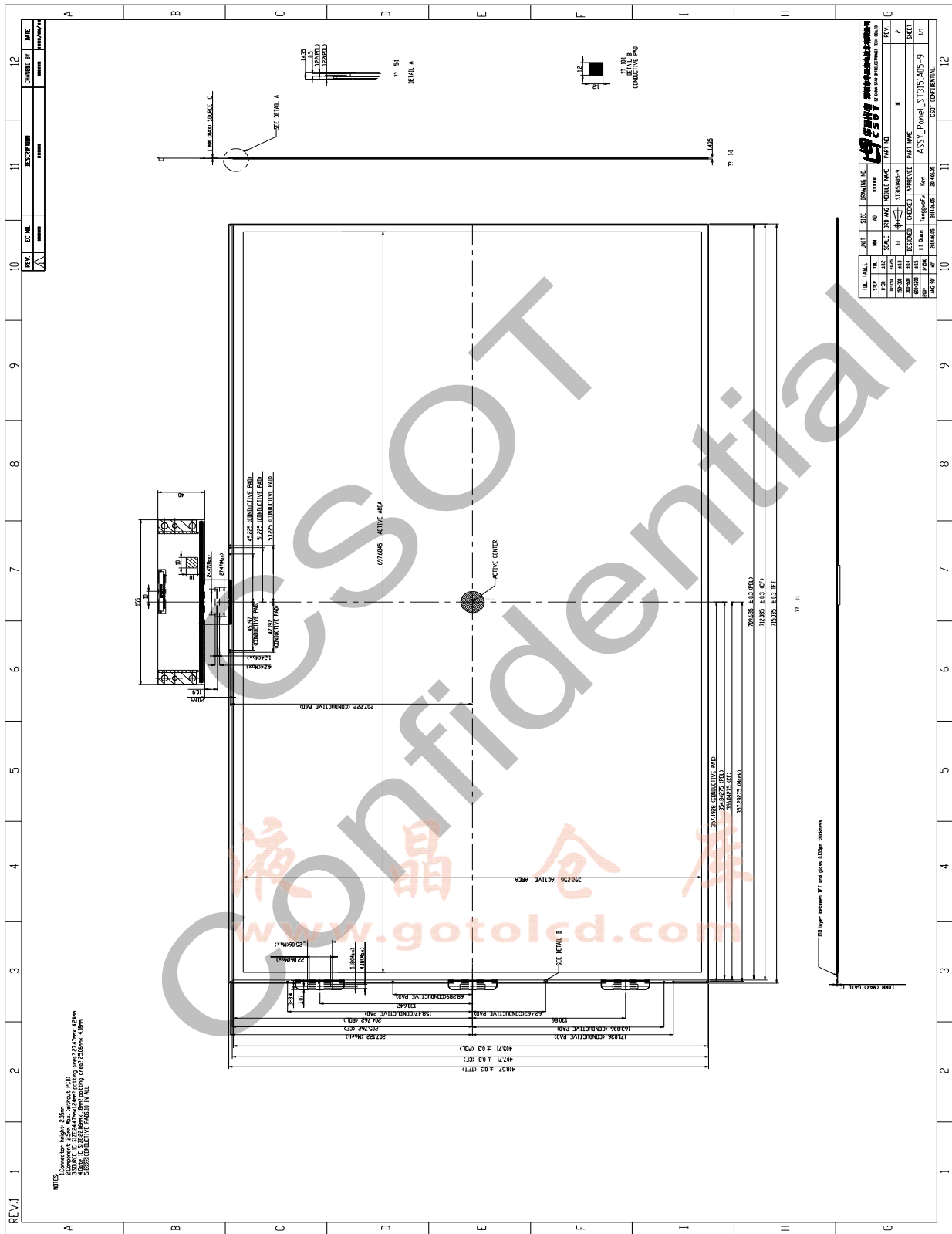

Fig. 6.6 Viewing angle coordination system

7. Mechanical Characteristics

7.1 Mechanical Specification



7.2 Packing

7.2.1 Packing Specifications

Item	Specification		
	Quantity	Dimension (mm)	Weight (kg)
Packing Box	15 pcs / box	821.00 (L) x 551.00 (W) x 110.6(H)	Net Weight: 13.8 (Max.) Gross Weight: 18.70 (Max.)
Pallet	1	1150.00 (L) x 850.00 (W) x 120.00 (H)	Net Weight: 5.04
Stack Layer	11		
Boxes per Pallet	22 boxes / pallet		
Pallet after Packing	330 pcs / pallet	1150.00 (L) x 850.00 (W) x 984.00 (H)	Gross Weight: 417.80

7.2.2 Packing Method

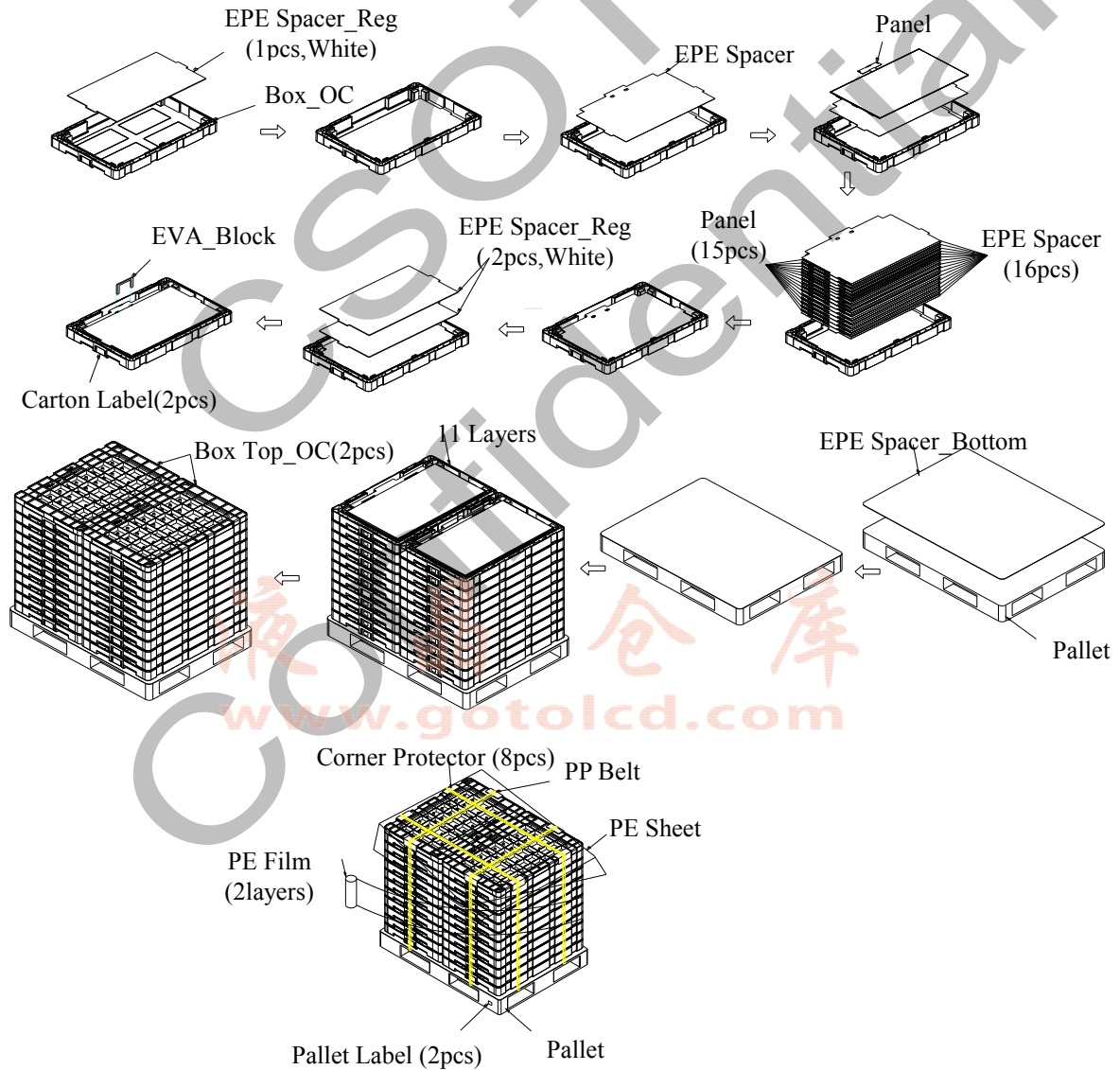

Fig. 7.1 Packing method

8. Definition of Labels

8.1 Open Cell Label



XXXXXXXXXXXXXXXXXXXXX XXXX ST3151A05-9 Ver. X.X

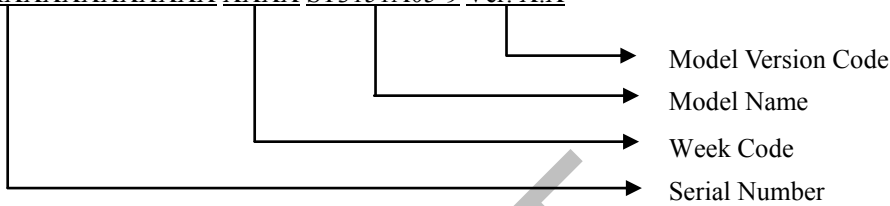

Serial Number: XXXXXXXXXXXXXXXX XXXXXXXX

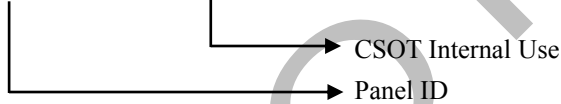

Week Code: XX XX

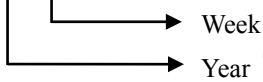

Year: 2010 = 10, 2011 = 11 ... 2020 = 20, 2021 = 21...

Week: 01, 02, 03 ...

Model Name: ST3151A05-9

Ver.X.X: Version, for example: 0.1, 0.2, ..., 1.1, 1.2, ..., 2.1, 2.2, ...

8.2 Carton Label



For RoHS compliant products, CSOT will add RoHS for identification.

Serial Number: XXXXXXXX XX XXXXX XXXXX

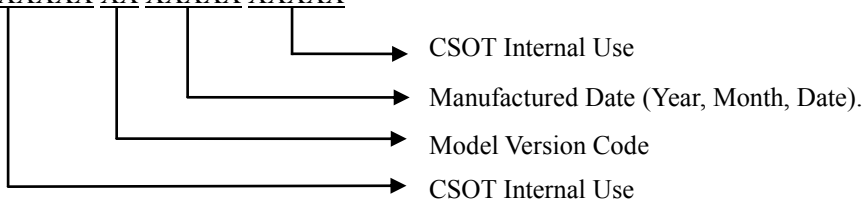

Manufactured Date:

Year: 2010 = 10, 2011 = 11...2020 = 20, 2021 = 21...

Month: 1~9, A~C, for Jan. ~ Dec.

Date: 01~31, for 1st to 31st

Model Version Code: Version of product, for example: 01, 02, 11, 12...

8.3 Pallet Label

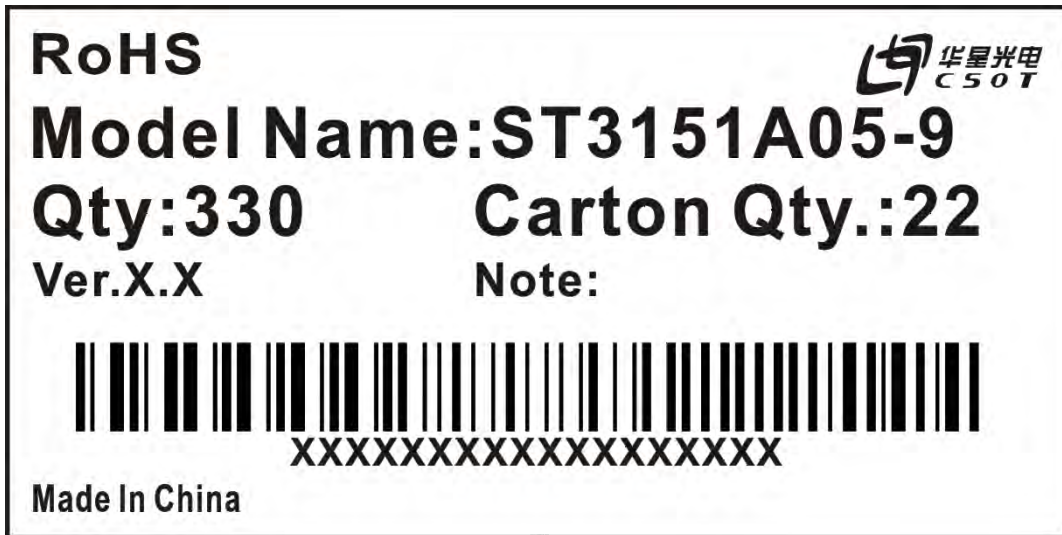

Serial Number: XXXXXX XX XXXXXX XXXXXX

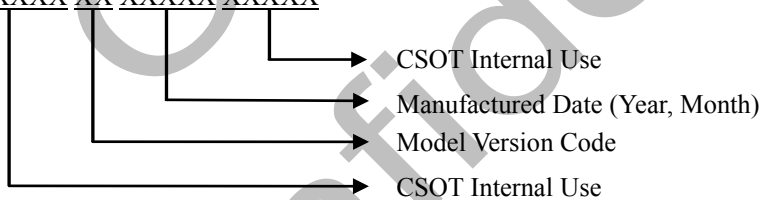

9. Precautions

9.1 Assembly and Handling Precautions

- (1)The device listed in the product specification sheets was designed and manufactured for TV application only.
- (2)Do not apply rough force such as bending or twisting to the open cell during assembly.
- (3)It is recommended to assemble or install a open cell into the user's system in clean working areas. The dust and oil may cause electrical short or damage the polarizer.
- (4)Do not apply pressure or impulse to the open cell to prevent the damage to the open cell.
- (5)Always follow the correct power-on sequence. This can prevent the damage and latch-up to the LSI chips.
- (6)Do not plug in or pull out the interface connector while the open cell is in operation.
- (7) Use soft dry cloth without chemicals for cleaning because the surface of polarizer is very soft and easily be scratched.
- (8)Moisture can easily penetrate into the open cell and may cause the damage during operation.
- (9)High temperature or humidity may deteriorate the performance of the open cell. Please store open cell in the specified storage conditions.
- (10) When ambient temperature is lower than 10 °C, the display quality might be deteriorated. For example, the response time will become slow.

9.2 Safety Precautions

- (1)If the liquid crystal material leaks from the panel, it should be kept away from the eyes or mouth. In case of contact with hands, skin or clothes, it has to be washed away thoroughly with soap.
- (2) After the open cell end of life, it is not harmful in case of normal operation and storage.