

ST3617 - Infrared remote control decoder RC5

The main function of the ST3617 is to decode the RC5 data received from remote control into 16 bit serial data output. There are two ways of getting data from chip, Data of 9600 baud rate or Serial Shift of data through RDY, CLK and DAT pins. Many remote control applications can be developed using the decoder.

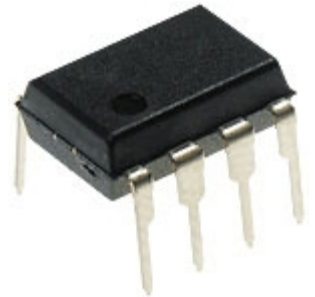

Block Diagram

ST3617 needs only one component to work that is IR receiver like TSOP1738 or similar. The data is output as simple 2 bytes of serial data consisting of 16 bits of information for each key press on the remote.

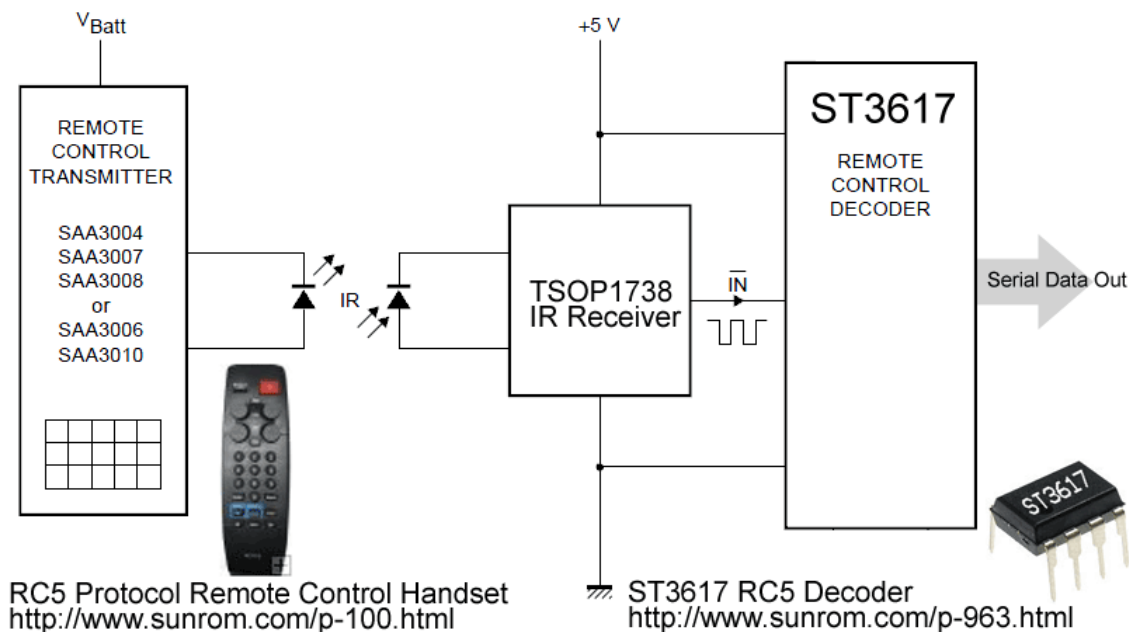

Specification

Parameter	Value
Working Voltage	3-5V DC
Current	10mA
Serial UART Interface	9600 bps, 8 bit data, no parity, 1 stop bit at 5V or 3V level
Serial Shift Interface	Uses three pins RDY, CLK and DAT to output decoded RC5 data

ST3617 is a Microchip PIC Controller that is programmed by us and labeled to work as per details in this datasheet.



Pin Details

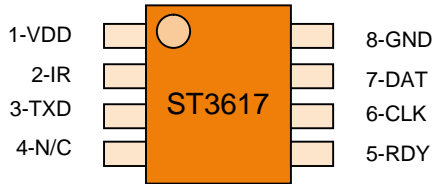

Pin#	Pin Name	Type	Notes
1	VDD	Supply	3 to 5V DC regulated power supply input
2	IR	Input	Connect IR receiver output to this pin
3	TXD	Output	Outputs serial UART data at 9600 bps at TTL level
4	N/C	Not Used	Not Connected, This pin is not used and should be left unconnected
5	RDY	Output	Ready Signal Output of Serial Shift Interface
6	CLK	Input	Clock Input of Serial Shift Interface
7	DAT	Output	Data Output of Serial Shift Interface
8	GND	Ground	Power Supply Ground

Data Interface for ST3617 RC5 Decoder

There are two ways you can get the output from ST3617. For each output the data is two bytes long containing total 16 bits RC5 data.

Two types of Interface for reading RC5 data from ST3617

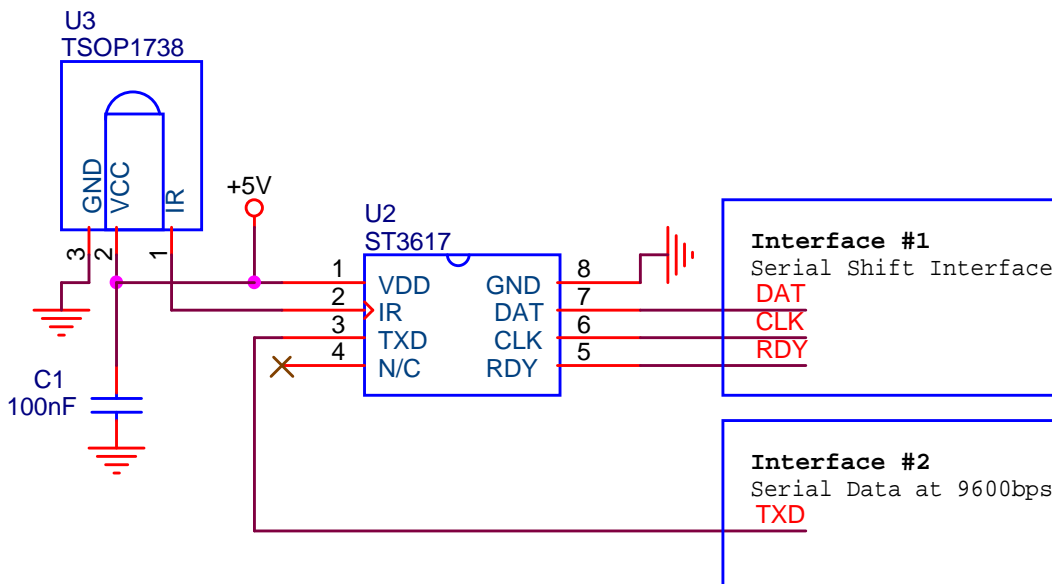

Interface #1 is Serial Shift Interface, which consist of three pins. In this interface you have to monitor RDY pin to go low which means new RC5 data has arrived. Then you shift output data using DAT and CLK pins. You can use any I/O of your application microcontroller.

Interface #2 is Serial Data at 9600 bps is particular useful when you have a dedicated serial input pin available on your application microcontroller to get

There are two type of Interface to get decoded RC5 data from ST3617, Any one of it can be used in the application.

the 2 bytes of data. You can also use the serial data to interface to PC using MAX232 level convertor for serial port or use USB-TTL chip to get a virtual serial port on PC to which many software like Hyperterminal can be connected. Custom software can also be made to monitor the incoming data.

Philips RC5 Protocol

Let us review the RC5 protocol to understand the RC5 decoder IC ST3617 better. The RC5 code from Philips is possibly the most used protocol by hobbyists, probably because of the wide availability of cheap remote controls.

The protocol is well defined for different device types ensuring compatibility with your whole entertainment system.

RC5 Protocol Remote Control Handset

<http://www.sunrom.com/p-100.html>



Features of Protocol

- 5 bit address and 6 bit command length
- Bi-phase coding (aka Manchester coding)
- Carrier frequency of 36kHz or 38kHz
- Constant bit time of 1.778ms (64 cycles of 36 kHz), Different timing for 38Khz, Should be adjusted in decoder part by monitoring first two bits.
- Manufacturer Philips

Modulation

RC5 Modulation The protocol uses bi-phase modulation (or so-called Manchester coding) of a 36kHz IR carrier frequency. All bits are of equal length of 1.778ms in this protocol, with half of the bit time filled with a burst of the 36kHz carrier and the other half being idle. A logical zero is represented by a burst in the first half of the bit time. A logical one is represented by a burst in the second half of the bit time. The pulse/pause ratio of the 36kHz carrier frequency is 1/3 or 1/4 which reduces power consumption.

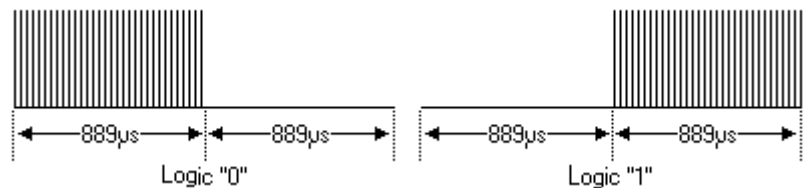

Protocol

The drawing below shows a typical pulse train of an RC-5 message. This example transmits command \$35 to address \$05.

RC-5 Pulse Train

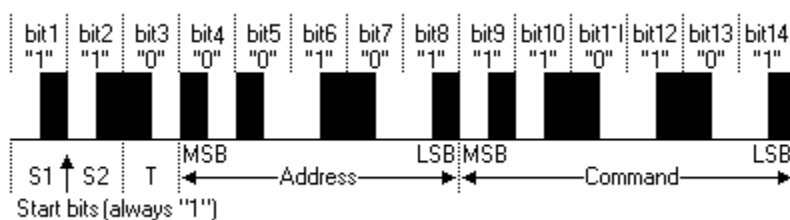

The first two pulses are the start pulses, and are both logical "1". Please note that half a bit time is elapsed before the receiver will notice the real start of the message.

The 3rd bit is a toggle bit. This bit is inverted every time a key is released and pressed again. This way the receiver can distinguish between a key that remains down, or is pressed repeatedly.

The next 5 bits represent the IR device address, which is sent with MSB first. The address is followed by a 6 bit command, again sent with MSB first.

A message consists of a total of 14 bits, which adds up to a total duration of 25 ms. Sometimes a message may appear to be shorter because the first half of the start bit S1 remains idle. And if the last bit of the message is a logic "0" the last half bit of the message is idle too.

As long as a key remains down the message will be repeated every 114ms. The toggle bit will retain the same logical level during all of these repeated messages. It is up to the receiver software to interpret this auto repeat feature.

Output Data format

Output from ST3617 is in two bytes, thus making total 16 bits of data, let us see meaning of each bit

High Byte - First

Bit Position->	15	14	13	12	11	10	9	8
Value	0	0	1	1	T	A4	A3	A2
	Always 0	Always 0	Always 1	Always 1	Toggle Bit 0 or 1	Address	Address	Address

Low Byte - Second

Bit ->	7	6	5	4	3	2	1	0
Value	A1	A0	D5	D4	D3	D2	D1	D0

A4-A0 = RC5 address of remote control, For TV remote this is zero.

D5-D0 = RC5 command for each keypress at remote control. For Key 1 its 1, Key 2 = 2 and such, Find a table on last of this datasheet showing key value for each key press.

Example

For example pressing Key 1 on remote control can output 0x3001 where 0x30 is high byte and 0x01 is low byte.

If we interpret, in terms of RC5 data we get below

High: 0x30 in binary is

Bit ->	15	14	13	12	11	10	9	8
Data->	0	0	1	1	0	0	0	0
					Toggle	A4	A3	A2

Low: 0x01 in binary is

Bit ->	7	6	5	4	3	2	1	0
Data->	0	0	0	0	0	0	0	1
Value	A1	A0	D5	D4	D3	D2	D1	D0

Note the Toggle is zero in this example, It can also be one, in this case you can get 0x3801 for key1 value. If you keep the Key1 pressed, the next output will have toggle value same as zero. If you leave Key1 and then press again, the toggle value will be one. Therefore toggle tells you if user is keeping the key press or left the key once and pressed again. This is particular useful if you are implementing Toggle output like Relay ON and OFF logic.

The Address bits A0 to A4 are zero since TV remote has zero RC5 address.

The Command bits D0 to D5 are 0x01 since User has pressed Key1 and value of key1 is 1.

Serial Data Output Format

When you see data output from chip in serial at 9600 baud rate, you will get total six bytes output as each key press in ASCII format so you can view it on screen.

Let us see what data output you will get in serial mode. The last two bytes in serial mode are new line characters so that when you see this data in terminal you can see each new data in new line. If you press Key1 on remote, you will get following output

Example Output of Serial in terminal software for Key1:

3001<CR><LF>

Interpreting above result in below table

BYTE COUNT	HEX	DECIMAL	CHARACTER DISPLAYED	Details
1	0x33	51	'3'	RC5 Data High Byte
2	0x30	48	'0'	RC5 Data High Byte
3	0x30	48	'0'	RC5 Data Low Byte
4	0x31	49	'1'	RC5 Data Low Byte
5	0x0D	13	'\r' = CR	New Line Character
6	0x0A	10	'\n' = LF	New Line Character

The above values in serial data are ASCII characters. You can convert the value to binary to use in your program by deducting 0x30 from ASCII value. Our sample code given on next page uses this technique to convert this ASCII buffer of four digit to single integer of RC5 data variable containing 16 bits.

Application example using serial data

We have used AT89C51's RXD pin to receive serial data from ST3617 and we switch on Relay ON or OFF for Key1 pressed on Remote. Key1 when first pressed will turn relay ON and Key1 pressed again will make Relay OFF. Relay used is 5V type. But can be any voltage if you have higher voltage available on your application. You can use any microcontroller to interface using this interface. We have chosen AT89C51 to show since it is more widely used. The sample code we have given can be adapted to any C compiler or any microcontrollers like AVR or PIC since with minor changes.

Source code can be downloaded from

<http://www.sunrom.com/files/3617-samplecode.zip>

Code is compiled using keil compiler

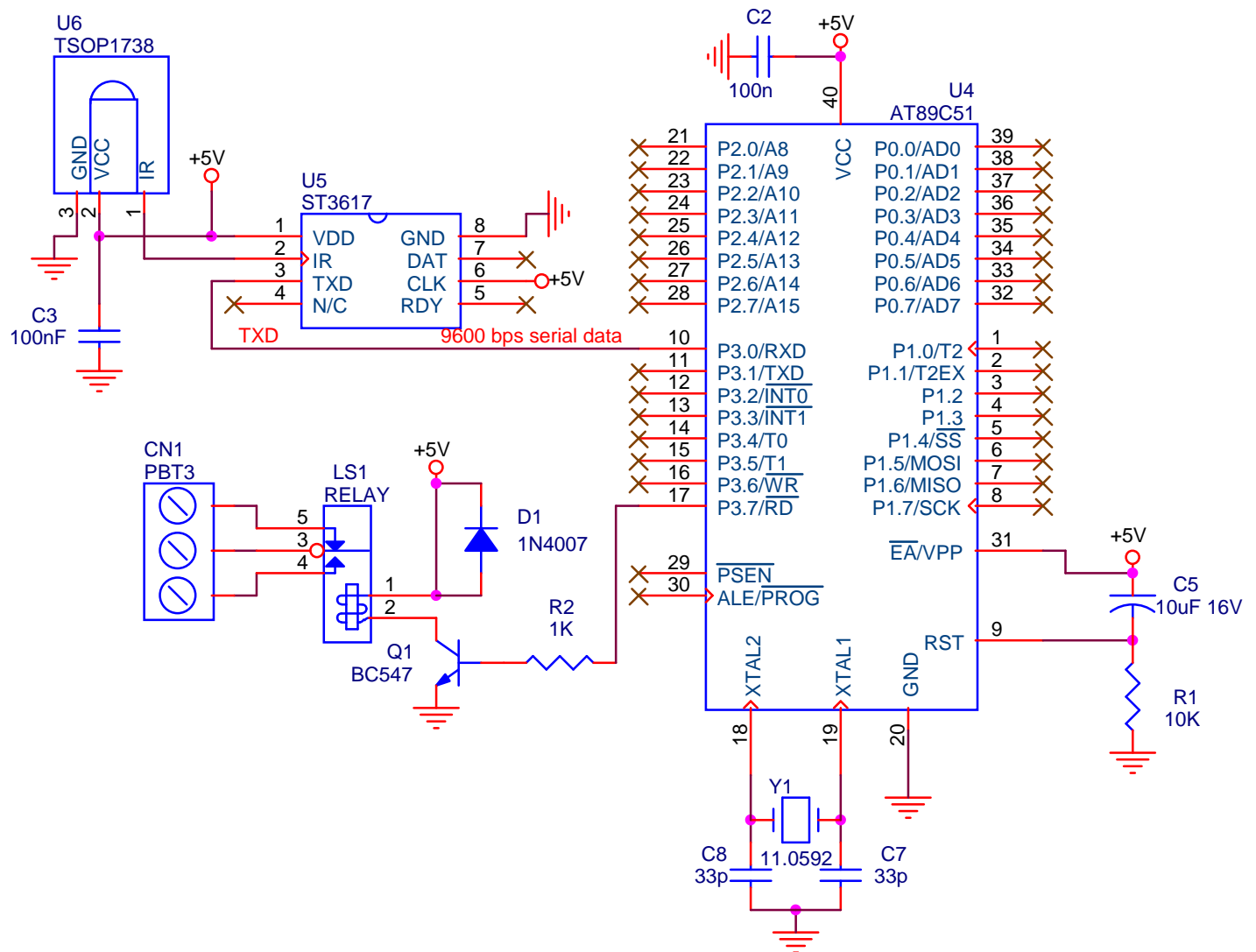

IMPORTANT: In serial data mode, the CLK pin#6 has to be connected to +5V to get data from TXD pin as shown above.

Application example using serial shift data

Advantage of this technique is it uses three general purpose I/O pins of MCU instead of dedicated RXD pin. This will make RXD available for other applications. We have used AT89C51's I/O pin to receive data from ST3617 and we switch on Relay ON or OFF for Key1 pressed on Remote. Key1 when first pressed will turn relay ON and Key1 pressed again will make Relay OFF. Relay used is 5V type. But can be any voltage if you have higher voltage available on your application. You can use any microcontroller to interface using this interface. We have chosen AT89C51 to show since it is more widely used. The sample code we have given can be adapted to any C compiler or any microcontrollers like AVR or PIC since with minor changes.

Source code can be downloaded from

<http://www.sunrom.com/files/3617-samplecode.zip>

Code is compiled using keil compiler

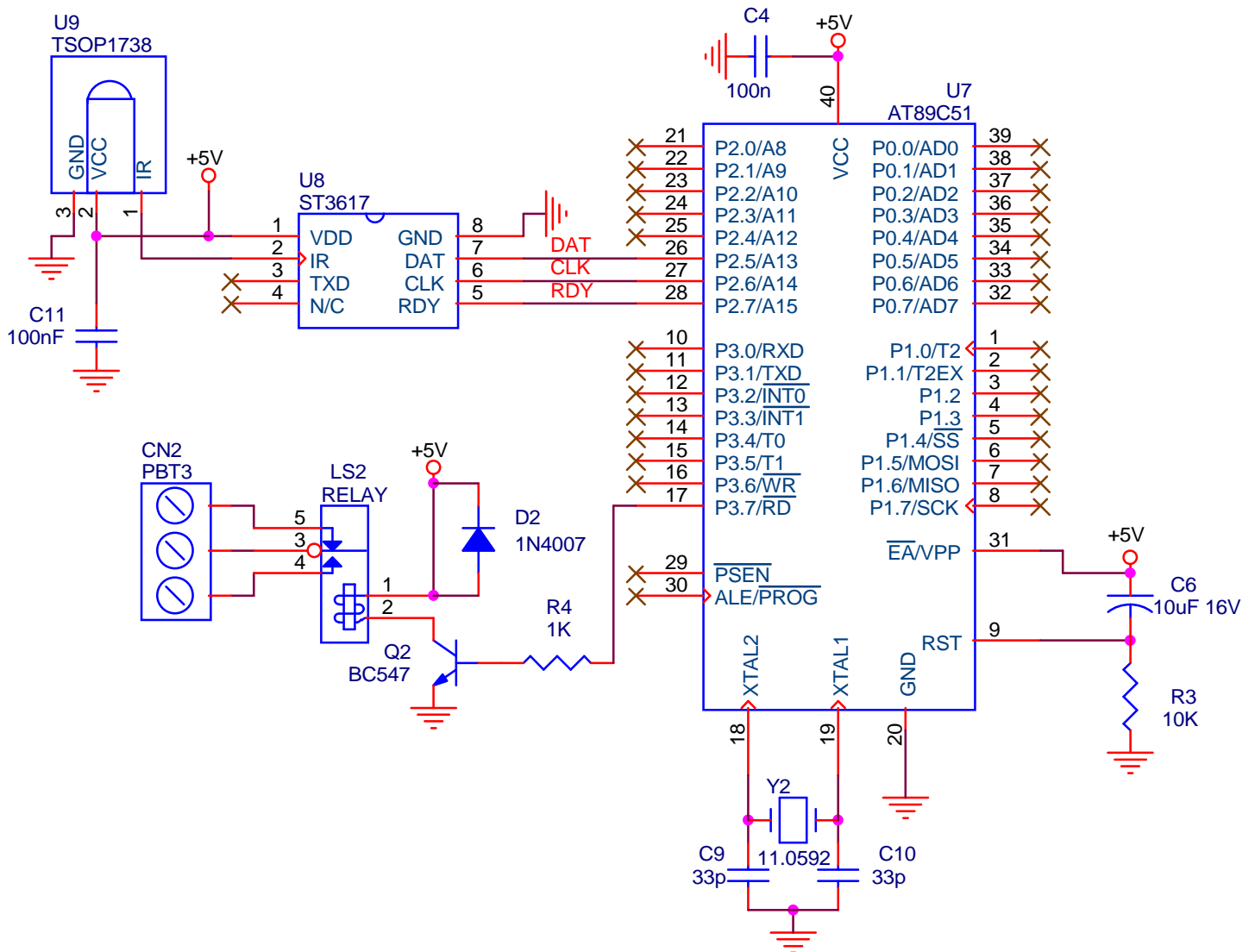

RC5 address and command Table

Commonly used Address and Command data are as per table below

RC5 ADDRESS of Remote Control	EQUIPMENT
0	TV SET 1
1	TV SET 2
2	VIDEOTEXT
3	EXPANSION FOR TV 1 AND 2
4	LASER VIDEO PLAYER
5	VIDEO RECORDER 1 (VCR 1)
6	VIDEO RECORDER 2 (VCR 2)
7	RESERVED
8	SAT 1
9	EXPANSION FOR VCR 1 OR 2
10	SAT 2
11	RESERVED
12	CD VIDEO
13	RESERVED
14	CD PHOTO
15	RESERVED
16	AUDIO PREAMPLIFIER 1
17	RECEIVER / TUNER
18	TAPE / CASSETTE RECORDER
19	AUDIO PREAMPLIFIER 2
20	CD
21	AUDIO RACK
22	AUDIO SAT RECEIVER
23	DCC RECORDER
24	RESERVED
25	RESERVED
26	WRITABLE CD
26-31	RESERVED

Keypress in Remote Control are RC5 commands

RC5 COMMAND (in decimal)	DESCRIPTION of FUNCTION
0-9	NUMERIC KEYS 0 - 9
12	STANDBY
13	MUTE
14	PRESETS
16	VOLUME UP
17	VOLUME DOWN
18	BRIGHTNESS +
19	BRIGHTNESS -
20	COLOR SATURATION +
21	COLOR SATURATION -
22	BASS UP
23	BASS DOWN
24	TREBLE +
25	TREBLE -
26	BALANCE RIGHT
27	BALANCE LEFT
48	PAUSE
50	FAST REVERSE
52	FAST FORWARD-
53	PLAY
54	STOP
55	RECORD
63	SYSTEM SELECT

Dimensions DIP Package

8-Lead Plastic Dual In-line (P) – 300 mil (PDIP)

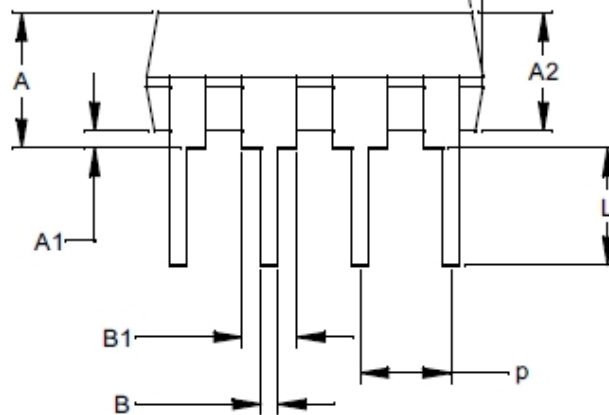
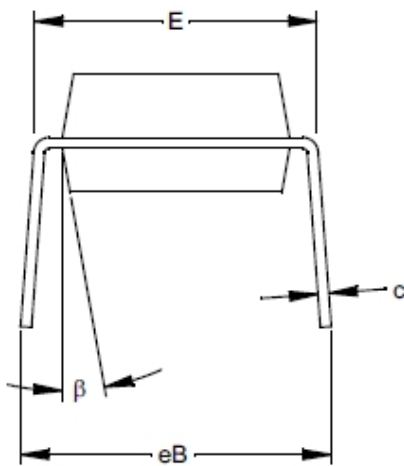
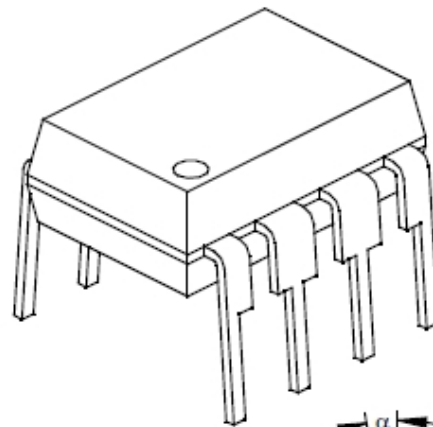
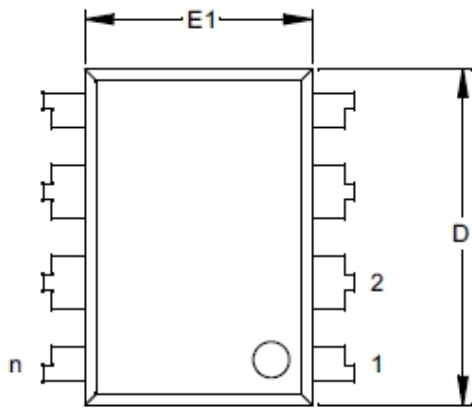

Units		INCHES*			MILLIMETERS		
Dimension Limits		MIN	NOM	MAX	MIN	NOM	MAX
Number of Pins	n		8			8	
Pitch	p		.100			2.54	
Top to Seating Plane	A	.140	.155	.170	3.56	3.94	4.32
Molded Package Thickness	A2	.115	.130	.145	2.92	3.30	3.68
Base to Seating Plane	A1	.015			0.38		
Shoulder to Shoulder Width	E	.300	.313	.325	7.62	7.94	8.26
Molded Package Width	E1	.240	.250	.260	6.10	6.35	6.60
Overall Length	D	.360	.373	.385	9.14	9.46	9.78
Tip to Seating Plane	L	.125	.130	.135	3.18	3.30	3.43
Lead Thickness	c	.008	.012	.015	0.20	0.29	0.38
Upper Lead Width	B1	.045	.058	.070	1.14	1.46	1.78
Lower Lead Width	B	.014	.018	.022	0.36	0.46	0.56
Overall Row Spacing	§ eB	.310	.370	.430	7.87	9.40	10.92
Mold Draft Angle Top	α	5	10	15	5	10	15
Mold Draft Angle Bottom	β	5	10	15	5	10	15

* Controlling Parameter

§ Significant Characteristic

Related Products

RC5 Remote Control

<http://www.sunrom.com/rf-wireless/ir-remote-control/rc5-protocol-remote-control-handset>

Remote control for transmitting RC5 data



SAA3010

<http://www.sunrom.com/p-998.html>

RC5 transmitter IC



USB to Serial TTL

<http://www.sunrom.com/usb-to-serial-rs232/usb-to-serial-ttl-board>

Access ST3617 data to PC using this board, It installs virtual COM port on PC to which any terminal software can connect.



MAX232 Board

<http://www.sunrom.com/usb-to-serial-rs232/max232-board>

Convert TTL(3-5V) level data from ST3617 to RS232 level(+/- 12V) suitable for connected to serial port of PC.

