

TRIPLE VOLTAGE REGULATOR

- ONLY TWO CELL NEED AS INPUT
- THREE REGULATED OUTPUT
 - 1) HIGH EFFICIENCY PFM DC/DC CONVERTER 3.3V AT 200mA (87% EFFICIENCY)
 - 2) VERY LOW NOISE AND VERY LOW DROP V_{REG} (3V AT 20mA)
 - 3) VERY LOW NOISE AAND VERY LOW DROP V_{REG} (1.9V AT 20mA)
- LOGIC CONTROLLED ELECTRONIC SHUTDOWN
- LOW BATTERY DETECTOR
- VIRTUAL GND PIN
- TEMPERATURA RANGE: -40 TO 85°C

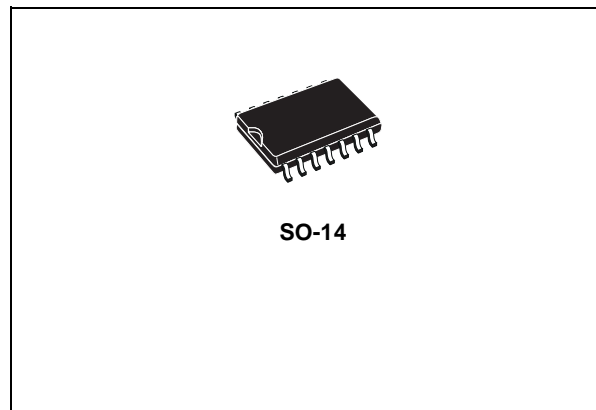

SCHEMATIC DIAGRAM

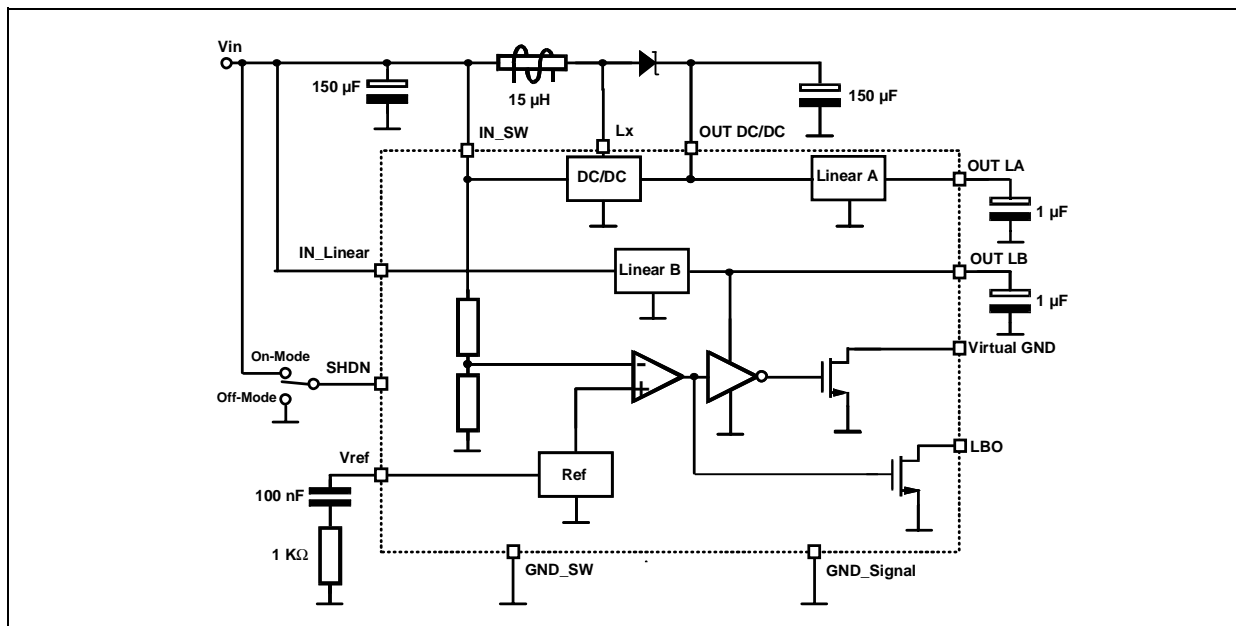

ST3M01

ABSOLUTE MAXIMUM RATINGS

Symbol	Parameter	Value	Unit
V _{IN}	DC Input Voltage (Both IN_Linear and IN_SW)	-0.3 to 7	V
V _{SHDN}	Shutdown Input Voltage	-0.3 to V _{IN} +0.3	V
V _{LX}	Switch Voltage	-0.3 to 7	V
V _{LBO}	Low Battery Output Voltage	-0.3 to 7	V
V _{virtual_GND}	Virtual GND Output Voltage	-0.3 to 7	V
I _{LBO}	Low Battery Output Maximum Current	30	mA
I _{virtual_GND}	Virtual GND Output Maximum Current	30	mA
T _{stg}	Storage Temperature Range	-65 to +150	°C
T _{op}	Operating Junction Temperature Range	-40 to +85	°C

THERMAL DATA

Symbol	Parameter	Value	Unit
R _{thj-amb}	Thermal Resistance Junction-ambient (*)	160	°C/W

ORDER CODES

Type	Package	Comment
ST3M01D	SO-14	50 parts per tube / 20 tube per box
ST3M01DTR	SO-14 (Tape & Reel)	2500 parts per reel

CONNECTION DIAGRAM (top view)

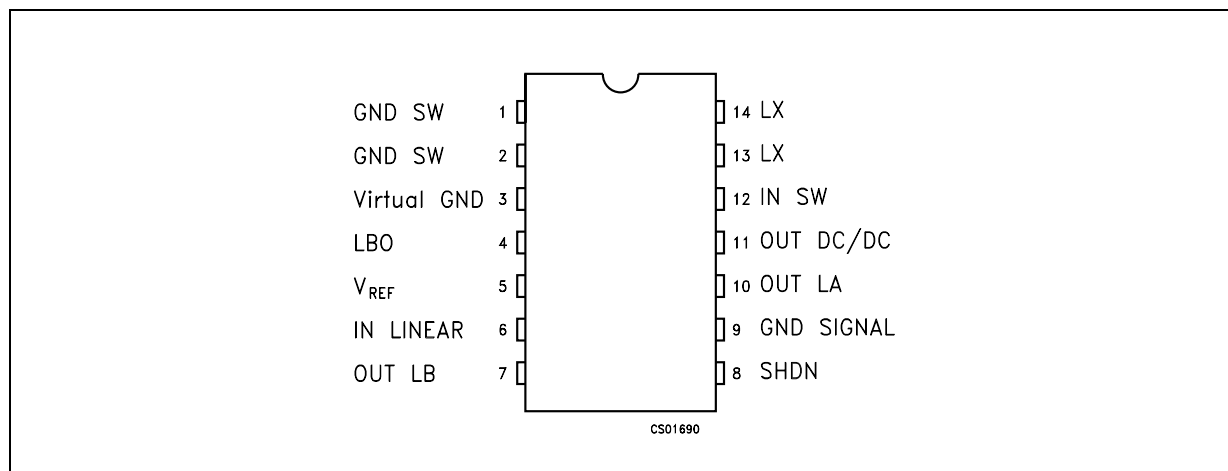

PIN DESCRIPTION

Pin N°	Symbol	Name and Function
1	GND SW	Switching Ground. Must be low impedance; solder directly to GND plane
2	GND SW	Switching Ground. Must be low impedance; solder directly to GND plane
3	Virtual GND	Virtual GND. Open Drain N-Channel MOSFET: must be high impedance when the Low Battery condition is detected.
4	LBO	Low Battery Output. Open Drain N-Channel MOSFET: sinks current when the input voltage drops below 2V typically.
5	V _{REF}	Reference Voltage Output. Bypass with 0.1 μF to improve the linears V _{REF} thermal noise performance.
6	IN Linear	Linear Input. Must be connected together with IN SW to the input supply.
7	OUT L _B	Linear B Output port. 1.9V typically.
8	SHDN	Shutdown Input. Disables the SMPS and L _A output, but the L _B , the reference voltage and the low battery comparator remain active.
9	GND Signal	Signal GND. Must be connected together with the Switching Ground.
10	OUT L _A	Linear A Output port. 3V typically.
11	OUT DC/DC	DC/DC Output Port: 3.3V typically.
12	IN SW	SMPS Input. Must be connected together with IN_Linear to the input supply.
13	LX	1.5A N-Channel Power MOSFET Drain.
14	LX	1.5A N-Channel Power MOSFET Drain.

ELECTRICAL CHARACTERISTICS (Unless otherwise specified, please refer to the typical operating circuit of the pag 1 for the external components values and connections. Unless otherwise noted $V_{SHDN}=HIGH$)

Symbol	Parameter	Test Conditions	Min.	Typ.	Max.	Unit
V_I	Operating Input Voltage		1.9		3.3	V
$V_{O(DC/DC)}$	DC/DC Converter Output Voltage (Test Circuit A)	$2.24 < V_{IN} < 3.3V$; $0 < I_{O(DC/DC)} < 200mA$; $0 < I_{O(LA)} < 20mA$; $0 < I_{O(LB)} < 20mA$; $-40 < T_J < 85^\circ C$	3.2	3.3	3.415	V
η	DC/DC Converter Efficiency	$V_{IN}=2.4V$; $I_{O(DC/DC)}=100mA$; $I_{O(LA)}=0mA$; $I_{O(LB)}=0mA$; $T_J = 25^\circ C$		87		%
$V_{O(LA)}$	Linear A Output Voltage (Test Circuit A)	$2.24 < V_{IN} < 3.3V$; $0 < I_{O(DC/DC)} < 200mA$; $0 < I_{O(LA)} < 20mA$; $0 < I_{O(LB)} < 20mA$; $-40 < T_J < 85^\circ C$	2.93	3	3.09	V
$V_{O(LB)}$	Linear B Output Voltage (Test Circuit A)	$2.24 < V_{IN} < 3.3V$; $0 < I_{O(DC/DC)} < 200mA$; $0 < I_{O(LA)} < 20mA$; $0 < I_{O(LB)} < 20mA$; $-40 < T_J < 85^\circ C$	1.86	1.9	1.955	V
$e_{N(LA)}$	Linear A Thermal Output Noise Voltage (Note 2)	$V_{IN}=2.4V$; $V_{O(DC/DC)}=3.5V$; $I_{O(LA)}=20mA$; $10 < f < 80KHz$; $C_{O(LA)}=1\mu F$; $C_{REF}=0.1\mu F$; $T_J = 25^\circ C$		60		μV_{rms}
$e_{N(LB)}$	Linear B Thermal Output Noise Voltage (Note 2)	$V_{IN}=2.4V$; $V_{O(DC/DC)}=3.5V$; $I_{O(LB)}=20mA$; $10 < f < 80KHz$; $C_{O(LB)}=1\mu F$; $C_{REF}=0.1\mu F$; $T_J = 25^\circ C$		35		μV_{rms}
$I_{q(OFF)}$	Quiescent Current OFF Mode DC/DC & L_A OFF L_B ON (Test Circuit E)	$V_{IN}=3.3V$; No Load; $V_{SHDN}=LOW$; $T_J = 25^\circ C$		75		μA
$I_{q(OFF)}$	Quiescent Current OFF Mode (DC/DC & L_A OFF L_B ON) (Test Circuit F)	$V_{IN}=1.9V$; No Load; $V_{SHDN}=HIGH$; $T_J = 25^\circ C$		50		μA
$I_{S(DC/DC)}$	DC/DC Supply Current (Test Circuit B)	$V_{IN}=2.24V$; No Load; $T_J = 25^\circ C$		100		μA
$I_{q(LA)}$	Linear A Quiescent Current (Test Circuit C)	$V_{IN}=2.24V$; $V_{O(DC/DC)}=3.5V$; $I_{O(LA)}=10mA$; $T_J = 25^\circ C$		220		μA
$I_{q(LB)}$	Linear B Quiescent Current (Test Circuit C)	$V_{IN}=2.24V$; $V_{O(DC/DC)}=3.5V$; $I_{O(LB)}=10mA$; $T_J = 25^\circ C$		75		μA
V_{BATT}	Low Battery Detection Range	$V_{SHDN}=HIGH$ with falling edge	1.96	2	2.04	V
$V_{BATT(HYS)}$	Low Battery Detection Hysteresys			150	200	mV
$R_{ON(LBO)}$	LBO $R_{DS(ON)}$	$V_{IN}=1.9V$; $I_D=5mA$; $T_J = 25^\circ C$		10		Ω
V_{ih}	Control Input Logic Low	$V_{IN}>2.24V$; $-40 < T_J < 85^\circ C$			0.4	V
V_{il}	Control Input Logic High	$V_{IN}>2.24V$; $-40 < T_J < 85^\circ C$	1.5			V
T_{on}	Timer On Response Time on DC/DC	$V_{IN}=2.4V$; $C_O=100\mu F$; $T_J = 25^\circ C$ $I_{O(DC/DC)}=200mA$ V_{SHDN} =from GND to $V_{SHDN(MAX)}$		0.6	9	ms
$R_{ON(V_GND)}$	Virtual GND $R_{DS(ON)}$	$V_{IN}>2.24V$; $I_D=5mA$; $T_J = 25^\circ C$		10		Ω

Note 1: For $V_{IN} < 1.9V$ the $V_{O(LB)}$ is out of regulation because of under dropout condition

Note 2: $V_{O(DC/DC)} = 3.5V$ force for an external DC source to avoid switching noise

DC/DC CONVERTER BLOCK DIAGRAM

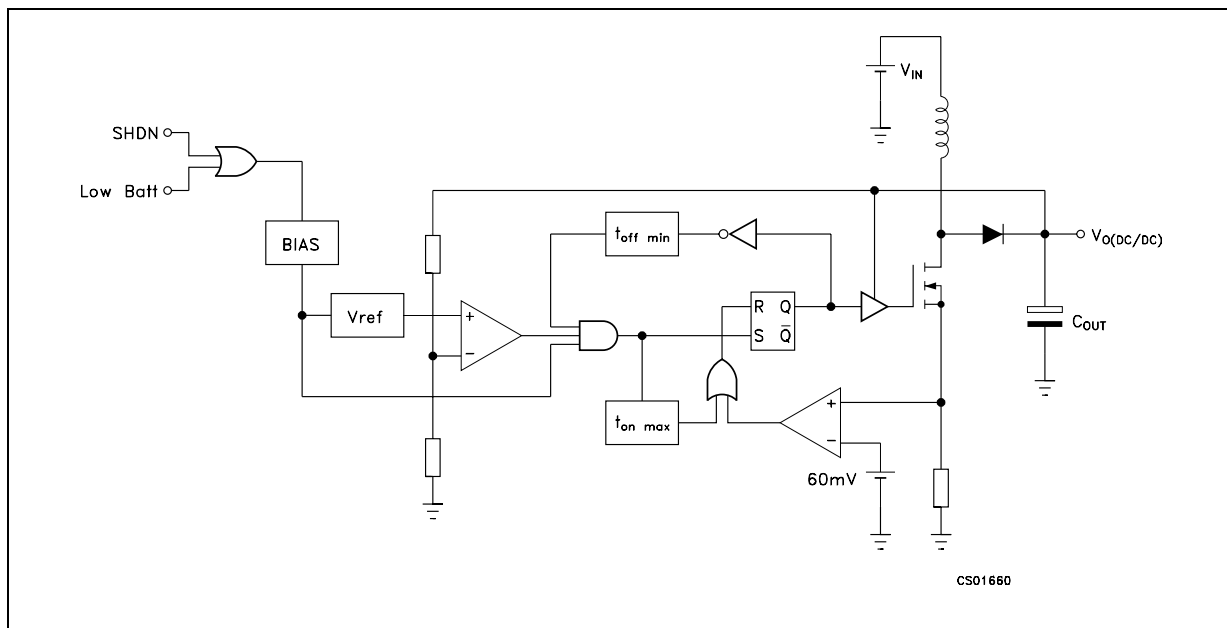

LINEAR VREG BLOCK DIAGRAM

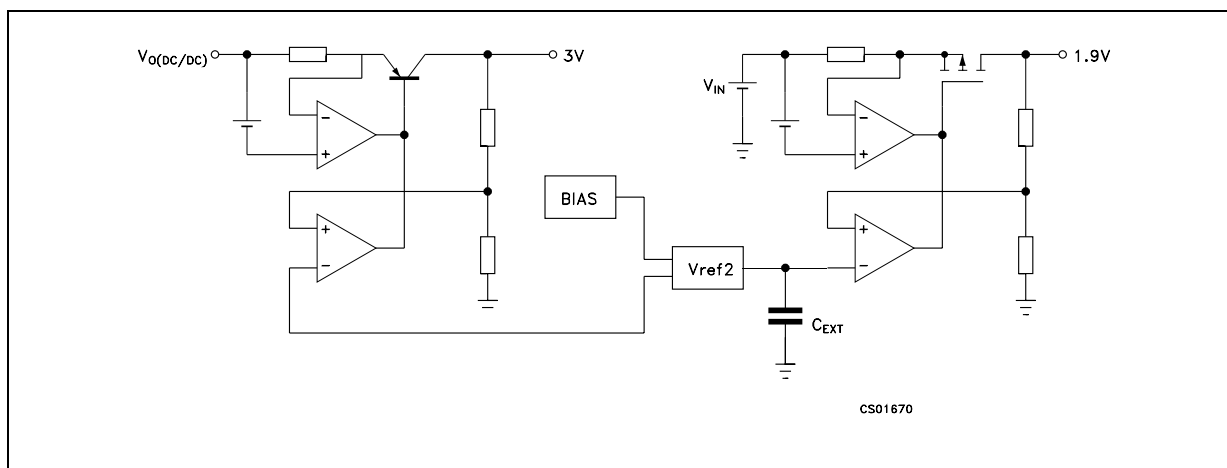

TEST CIRCUIT A

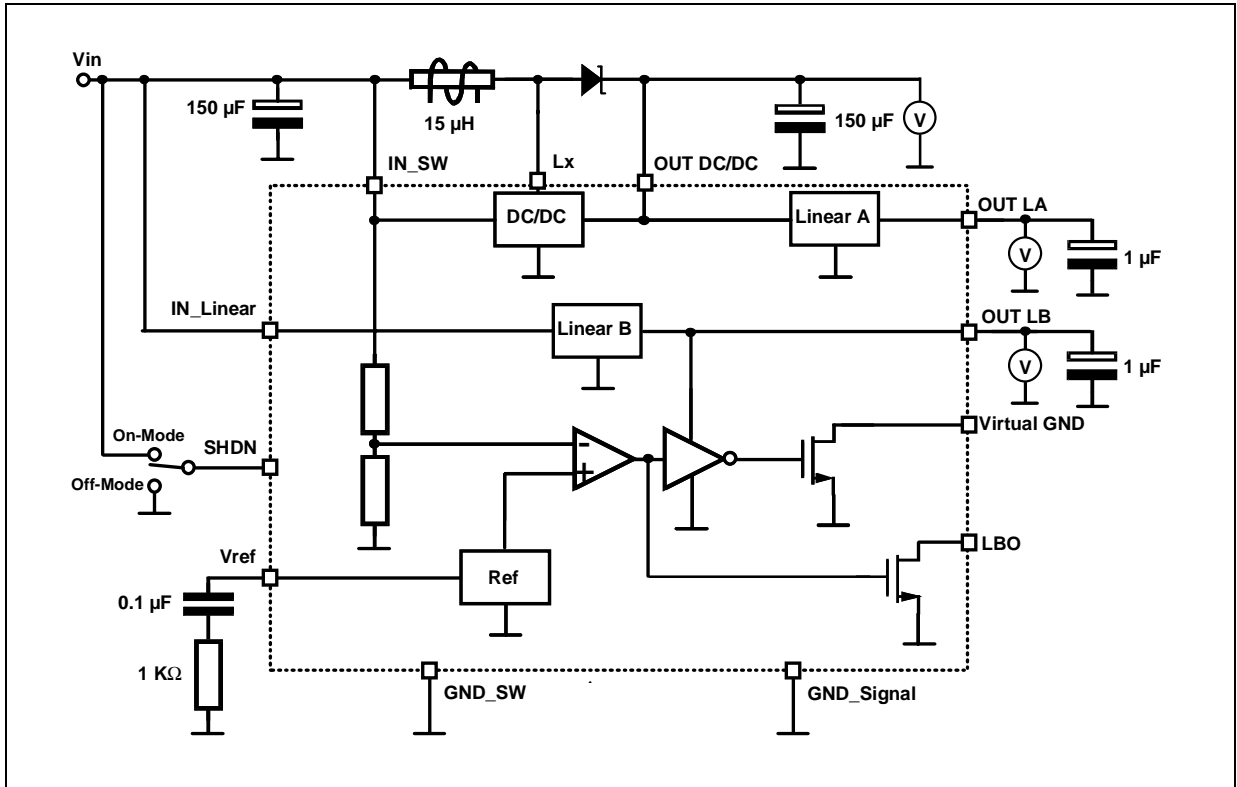

TEST CIRCUIT B

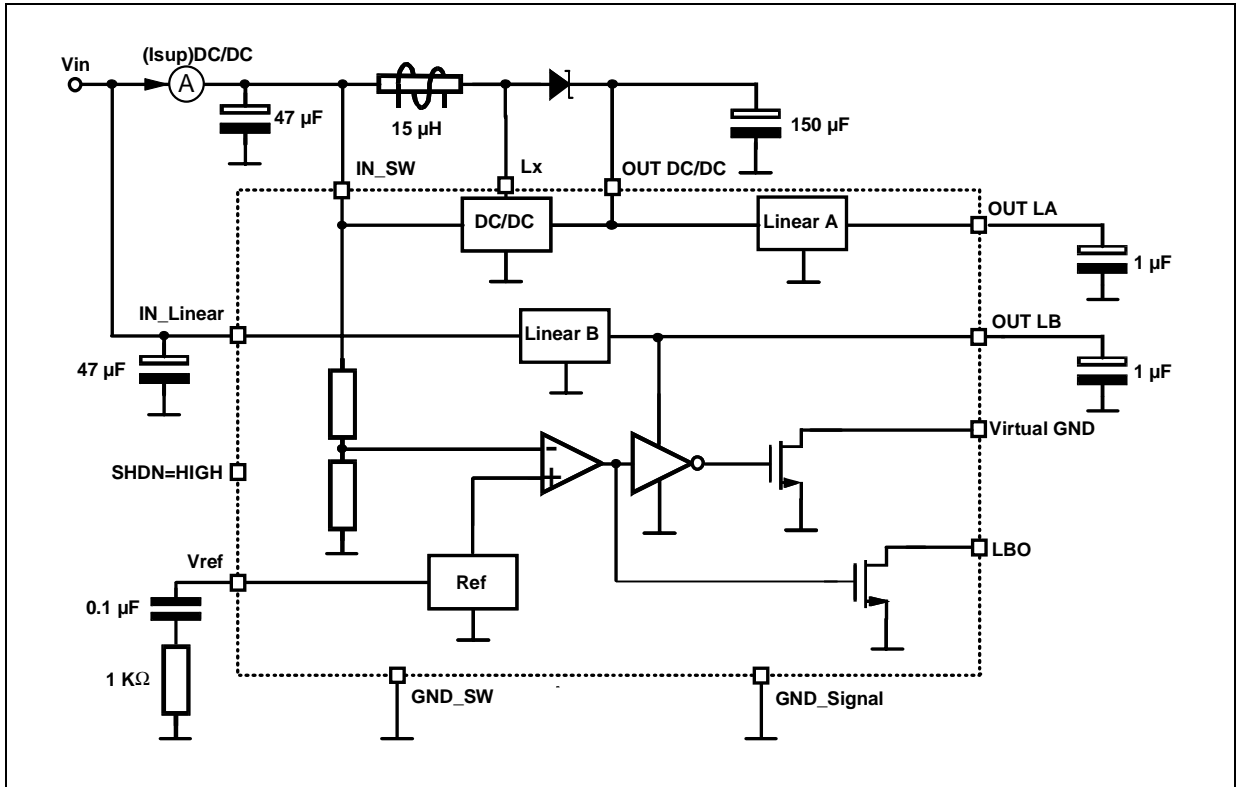

TEST CIRCUIT C $(I_q)_{Ia} = (I_{in})_{Ia} - (I_{out})_{Ia}$

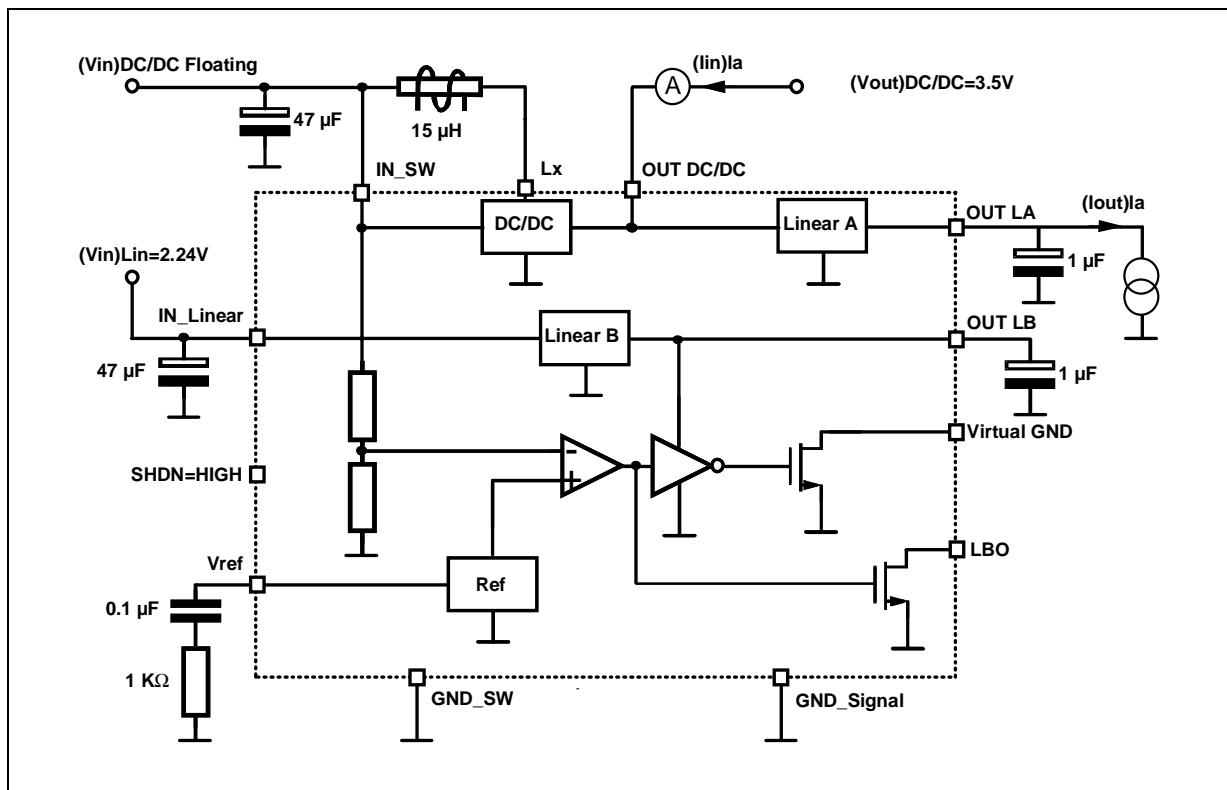

TEST CIRCUIT D $(I_q)_{Ib} = (I_{in})_{Ib} - (I_{out})_{Ib}$

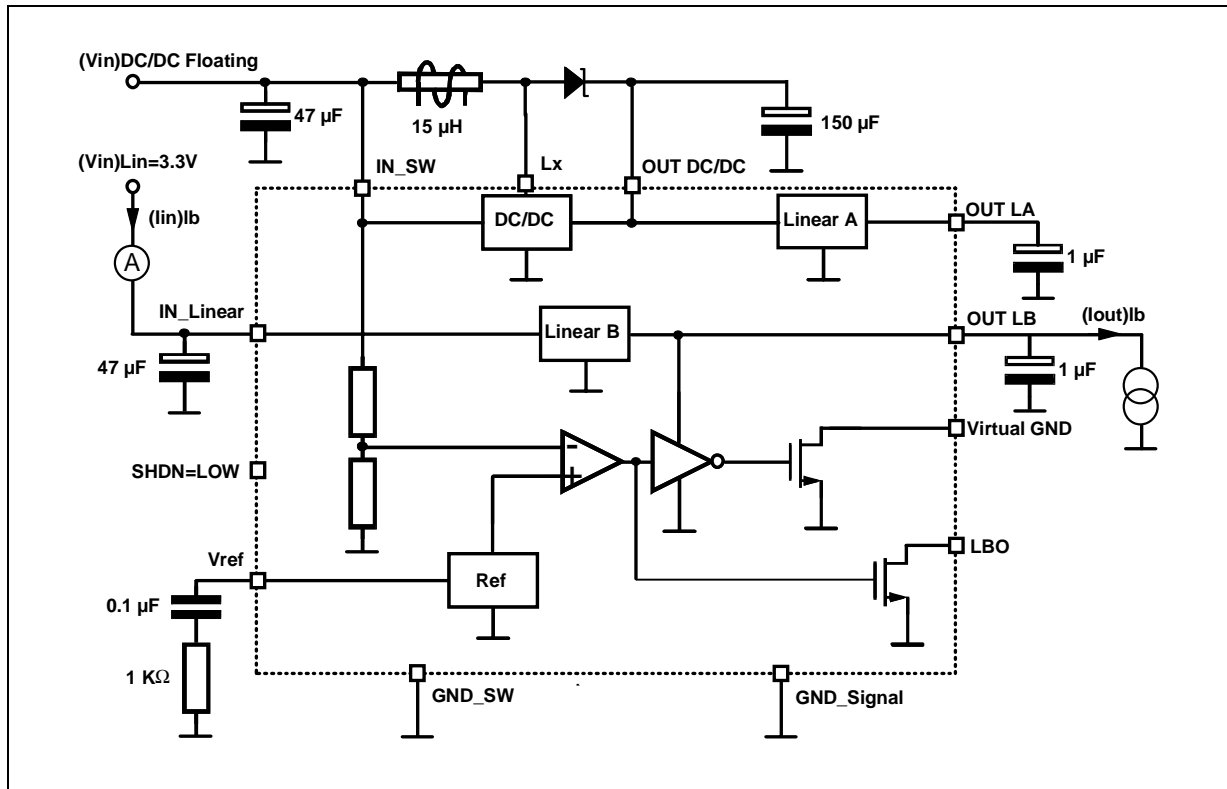

TEST CIRCUIT E

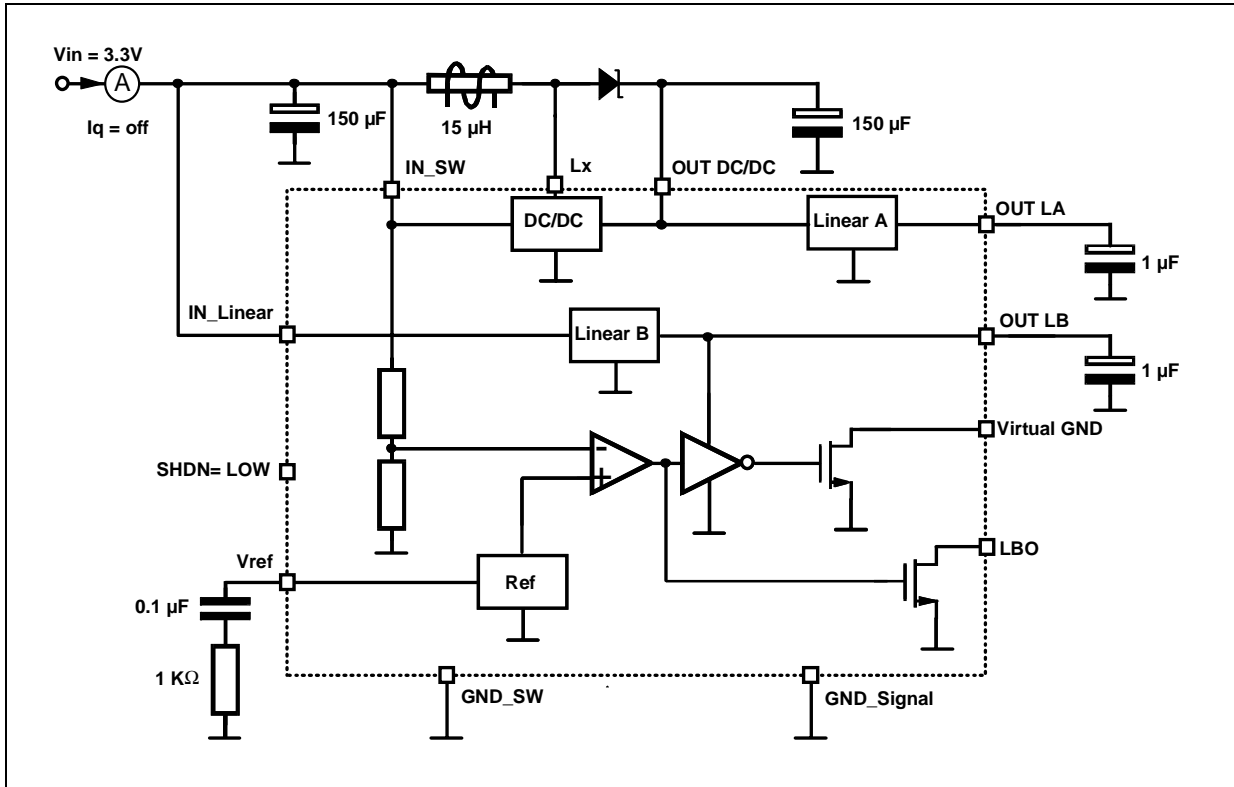

TEST CIRCUIT F

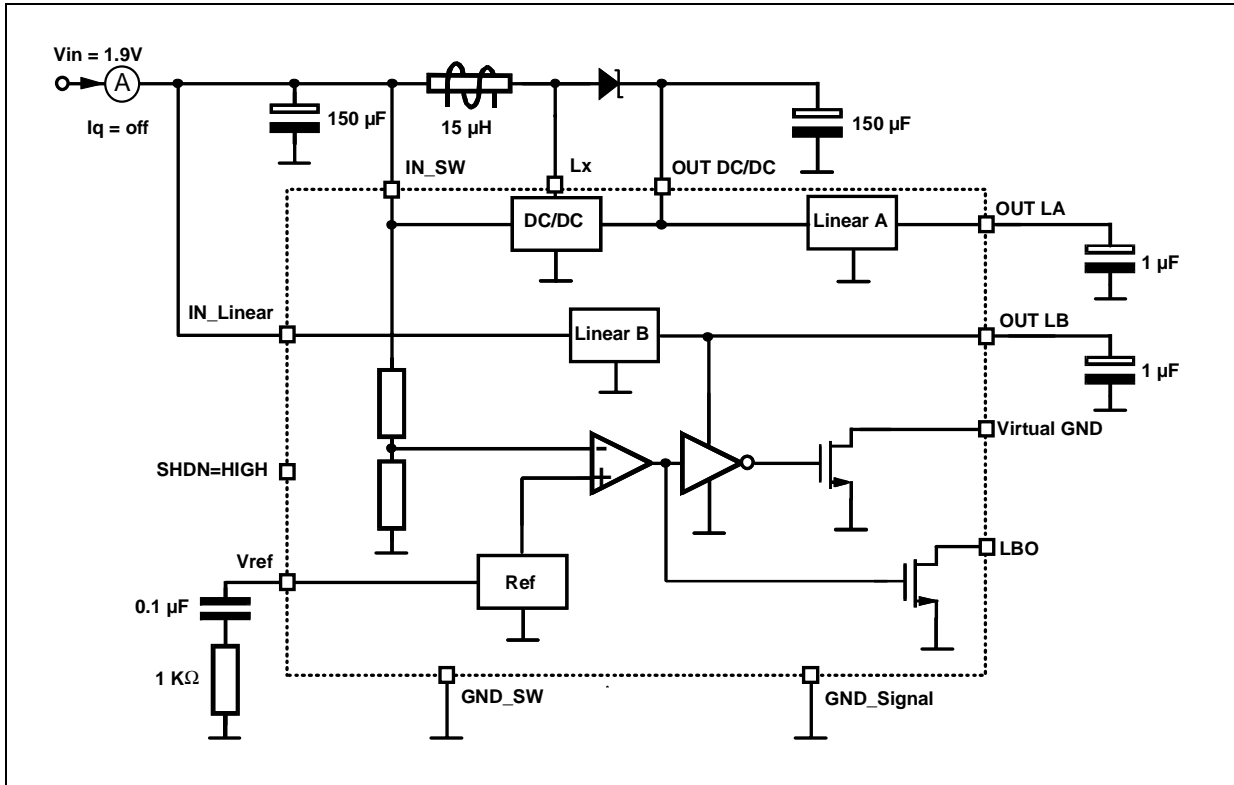

DEMOBOARD CIRCUIT

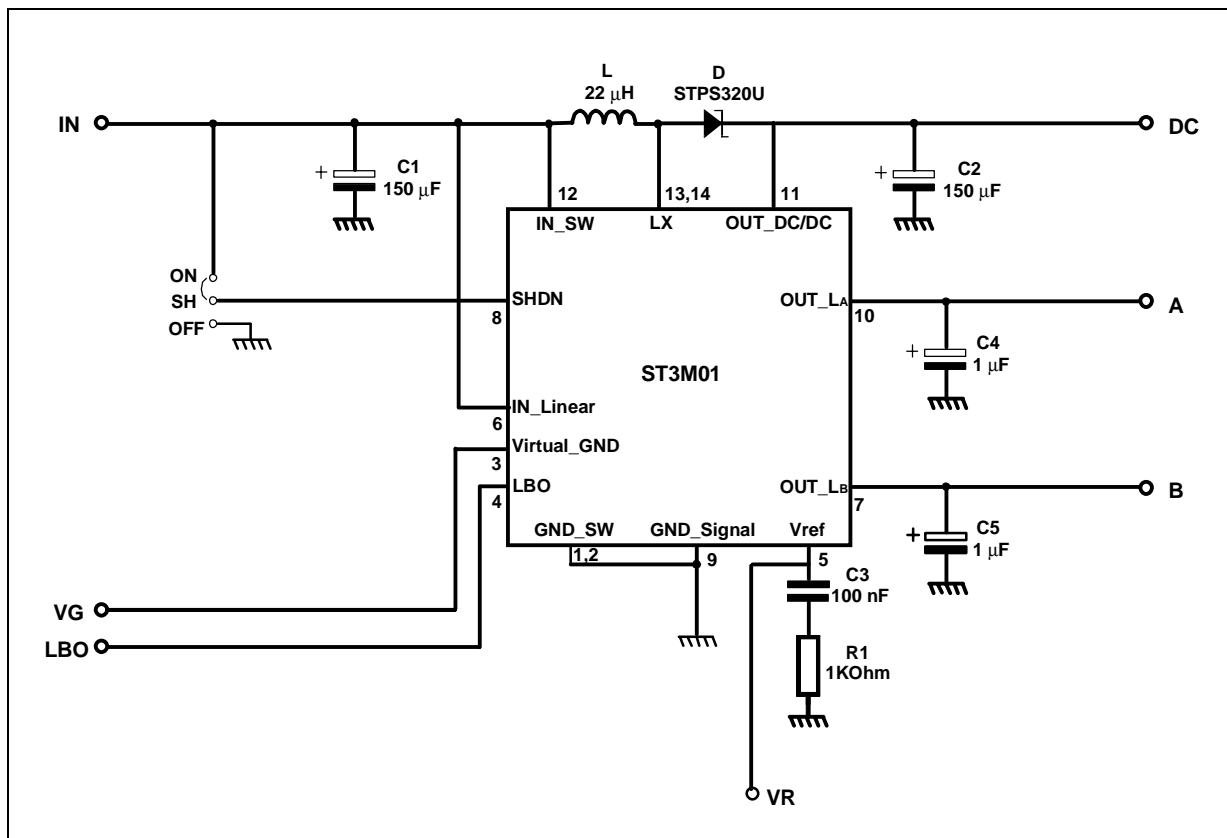

PC BOARD LAYOUT

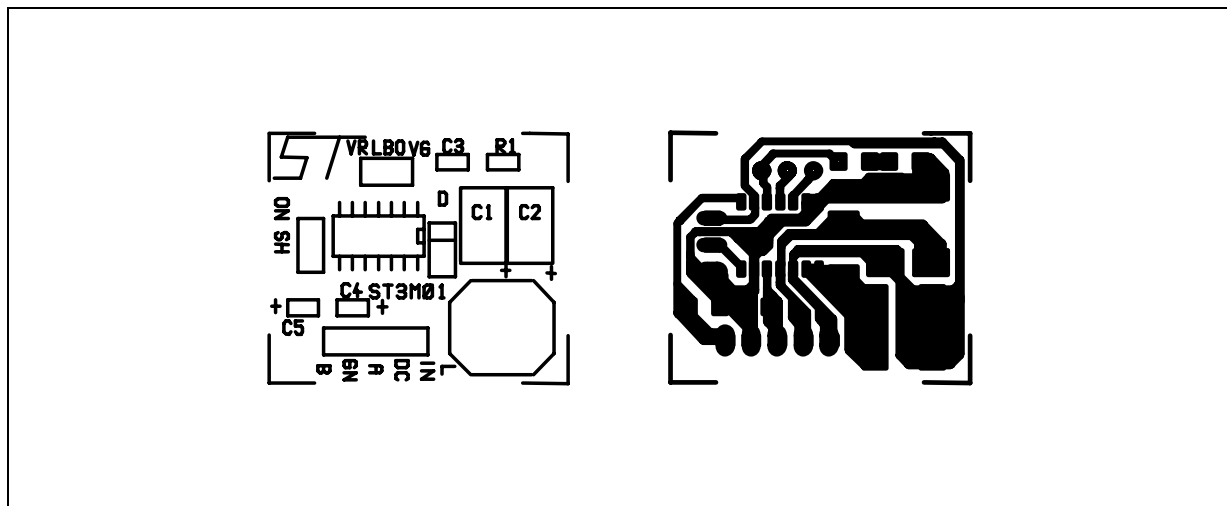

SO-14 MECHANICAL DATA

DIM.	mm			inch		
	MIN.	TYP.	MAX.	MIN.	TYP.	MAX.
A			1.75			0.068
a1	0.1		0.2	0.003		0.007
a2			1.65			0.064
b	0.35		0.46	0.013		0.018
b1	0.19		0.25	0.007		0.010
C		0.5			0.019	
c1	45 (typ.)					
D	8.55		8.75	0.336		0.344
E	5.8		6.2	0.228		0.244
e		1.27			0.050	
e3		7.62			0.300	
F	3.8		4.0	0.149		0.157
G	4.6		5.3	0.181		0.208
L	0.5		1.27	0.019		0.050
M			0.68			0.026
S	8 (max.)					

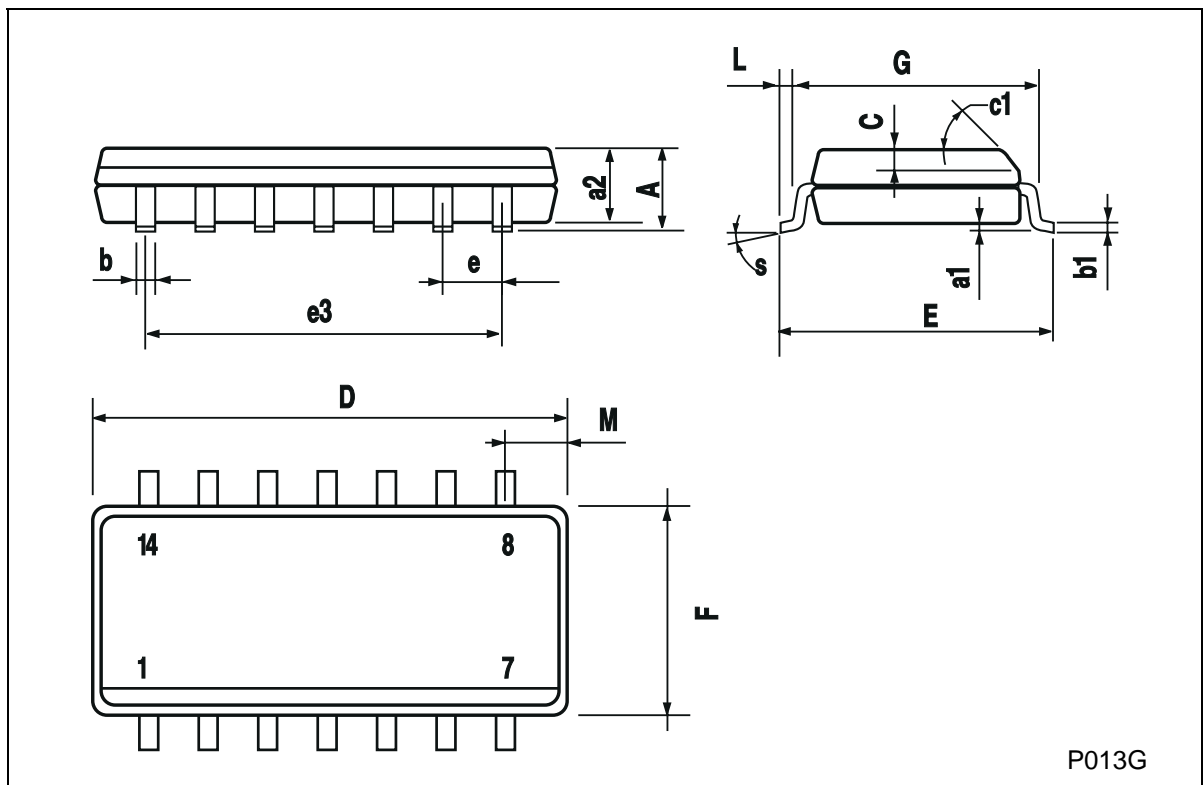

P013G

Information furnished is believed to be accurate and reliable. However, STMicroelectronics assumes no responsibility for the consequences of use of such information nor for any infringement of patents or other rights of third parties which may result from its use. No license is granted by implication or otherwise under any patent or patent rights of STMicroelectronics. Specifications mentioned in this publication are subject to change without notice. This publication supersedes and replaces all information previously supplied. STMicroelectronics products are not authorized for use as critical components in life support devices or systems without express written approval of STMicroelectronics.

© The ST logo is a registered trademark of STMicroelectronics

© 2000 STMicroelectronics - Printed in Italy - All Rights Reserved
STMicroelectronics GROUP OF COMPANIES

Australia - Brazil - China - Finland - France - Germany - Hong Kong - India - Italy - Japan - Malaysia - Malta - Morocco
Singapore - Spain - Sweden - Switzerland - United Kingdom

© <http://www.st.com>

