



# MODEL: ST4601B02-1

Ver. 0.1

Date: 08.Feb.2012

Customer's Approval	CSOT
Signature _____ Date _____	Approved By Product Director    Date _____ Name: Richard Lung Signature: _____
	Reviewed By PM Manager    Date _____ Name: Aaron Tu Signature: _____
	Reviewed By Project Leader    Date _____ Name: Joe Kuo Signature: _____
	Reviewed By PM    Date _____ Name: Chenguo Wu Signature: _____

## Contents

1. General Description .....	4
1.1 Product Features .....	4
1.2 Overview .....	4
1.3 General Information .....	4
2. Absolute Maximum Ratings .....	5
2.1 Absolute Maximum Ratings ( $T_A = 25 \pm 2 \text{ }^\circ\text{C}$ ) .....	5
2.2 Environment Requirement (Based on CSOT Module MT4601B02-1) .....	5
2.3 Absolute ratings of Environment (OPEN CELL) .....	5
3. Electrical Specification .....	6
3.1 Open cell Power Consumption ( $T_A = 25 \pm 2 \text{ }^\circ\text{C}$ ) .....	6
3.2 LVDS Characteristics .....	7
4. Input Terminal Pin Assignment .....	8
4.1 Interface pin assignment .....	8
4.2 Block Diagram of Interface .....	10
4.3 LVDS Interface .....	10
4.3.1 VESA Format (SELLVDS = H) .....	10
4.3.2 JEIDA Format (SELLVDS = L or Open) .....	10
5. Interface Timing .....	12
5.1 Timing Table (DE Only Mode) .....	12
5.2 Power On/Off Sequence .....	13
6. Optical Characteristics .....	14
6.1 Measurement Conditions .....	14
6.2 Optical Specifications .....	15
7. Mechanical Characteristics .....	18
7.1 Mechanical Specification .....	18
7.2 Packing .....	19
7.2.1 Packing Specifications .....	19
7.2.2 Packing Method .....	19
8. Definition of Labels .....	20
8.1 Open Cell Label .....	20
8.2 Carton Label .....	20
8.3 Pallet Label .....	21
9. Precautions .....	21
9.1 Assembly and Handling Precautions .....	22
9.2 Safety Precautions .....	22

## Revision History

Version	Date	Page (New)	Section	Description	Revision by
Ver. 0.1	08.Feb.2011	20	All	Tentative Specification was First Issued.	Chenguo Wu

CSOT  
Confidential

## 1. General Description

### 1.1 Product Features

- FHD Resolution (1920 x 1080)
- Very High Contrast Ratio: 4000:1
- Fast Response Time
- Ultra Wide Viewing Angle: 178° (H)/178° (V) (CR ≥ 10)
- DE (Data Enable) Mode
- LVDS (Low Voltage Differential Signaling) Interface

### 1.2 Overview

ST4601B02-1 is a diagonal 46.0" color active matrix LCD open cell with 2ch-LVDS interface. This open cell is a transmissive type display operating in the normally black mode. It supports 1920 x 1080 FHD resolution and can display up to 16.7M colors (8-bit). Each pixel is divided into Red, Green and Blue sub-pixels which are arranged in vertical stripe. There is no backlight built-in.

This open cell dedicates for LCD TV products and provides excellent performance which includes high transparency, ultra wide viewing angle and high color depth. CSOT open cell comply with RoHS for identification.

### 1.3 General Information

Item	Specification	Unit	Note
Active Area	1018.08 (H) x 572.67 (V)	mm	
Cell Size	1038.480(H) x 593.634 (V) x 1.900 (D)	mm	
Weight	2.35	kg	Max.
Driving Scheme	a-Si TFT Active Matrix	-	
Number of Pixels	1920 x 1080	pixel	
Pixel Pitch (Sub Pixel)	0.17675 (H) x 0.53025 (V)	mm	
Pixel Arrangement	RGB Vertical Stripe	-	
Display Colors	16.7 M	color	8-bit
Display Mode	Transmissive Mode, Normally Black	-	
Glass thickness (Array/CF)	0.7/0.7	mm	
Color Chromaticity	R=TBD G=TBD B=TBD W=(0.280, 0.290)		Typical value measured at CSOT's module: MT4601B02-1
Contrast Ratio	4000:1(Typ.)		
Cell Transmittance	5.9% (Typ.)	%	
View Angle(CR>10)	+89/-89(H),+89/-89(V) (Typ.)		
Polarizer(CF side)	Anti-glare, Haze 2%, Hard Coating (3H)		
Polarizer(TFT side)	Hard Coating (3H)		

## 2. Absolute Maximum Ratings

### 2.1 Absolute Maximum Ratings ( $T_A = 25 \pm 2 \text{ }^\circ\text{C}$ )

The followings are maximum values which, if exceeded, may cause damage to the unit.

Item	Symbol	Value		Unit
		Min.	Max.	
Power Supply Voltage	$V_{CC}$	- 0.3	13.5	V
Input Signal Voltage	$V_{IN}$	- 0.3	3.6	V

### 2.2 Environment Requirement (Based on CSOT Module MT4601B02-1)

(1) Temperature and relative humidity range are shown as below.

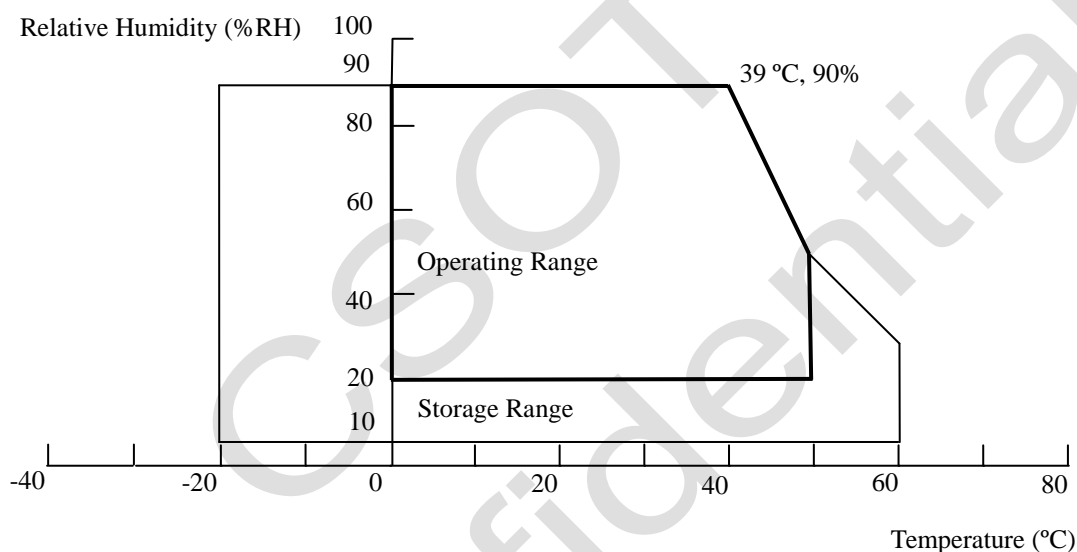

- (a) 90%RH maximum ( $T_A < 39 \text{ }^\circ\text{C}$ ).
- (b) Wet-bulb temperature should be 39 °C maximum ( $T_A > 39 \text{ }^\circ\text{C}$ ).
- (c) No condensation.

(2) The storage temperature is between - 20 °C to 60 °C, and the operating ambient temperature is between 0 °C to 50 °C.

The maximum operating temperature is based on the test condition that the surface temperature of display area is less than or equal to 65 °C with LCD module in a temperature controlled chamber alone. Thermal management should be considered in final product design to prevent the surface temperature of display area from being over 65 °C. The range of operating temperature may degrade in case of improper thermal management in the end product design.

(3) The rating of environment is based on LCD module. Leave LCD cell alone, this environment condition can't be guaranteed.

Except LCD cell, the customer has to consider the ability of other parts of LCD module and LCD module process.

### 2.3 Absolute ratings of Environment (Open Cell)

When storing open cell as spares for a long time, please follow the precaution instructions:

- (1) Do not store the module in high temperature and high humidity for a long time. It is highly recommended to store the module with temperature from 20 °C to 30 °C in normal humidity (50±10%RH) with shipping package.
- (2) The open cell should be keep within one month shelf life

### 3. Electrical Specification

#### 3.1 Open cell Power Consumption ( $T_A = 25 \pm 2 \text{ }^\circ\text{C}$ )

Parameter		Symbol	Value			Unit	Note
			Min.	Typ.	Max.		
Power Supply Voltage		$V_{CC}$	10.8	12.0	13.2	V	(1)
Rush Current		$I_{RUSH}$	-	-	2.3	A	(2)
Power Supply Current	White Pattern	$I_{CC}$	-	0.25	0.33	A	(3)
	Horizontal Stripe	$I_{CC}$	-	0.56	0.73	A	
	Black Pattern	$I_{CC}$	-	0.26	0.34	A	

Note:

- (1) The ripple voltage should be controlled less than 10% of  $V_{CC}$ .
- (2) Measurement condition:  $V_{CC}$  rising time = 470  $\mu\text{s}$ .

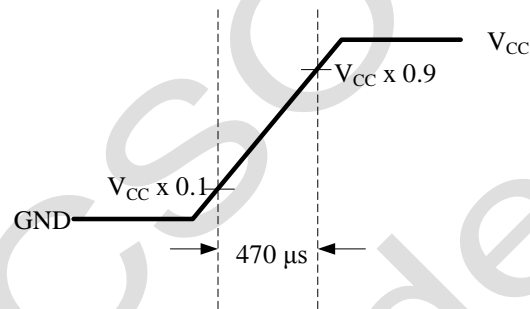

Fig. 3.1  $V_{CC}$  rising time condition

- (3) Measurement condition:  $V_{CC} = 12 \text{ V}$ ,  $T_a = 25 \pm 2 \text{ }^\circ\text{C}$ ,  $F = 60 \text{ Hz}$ . The test patterns are shown as below.

A. White Pattern



B. Horizontal Pattern

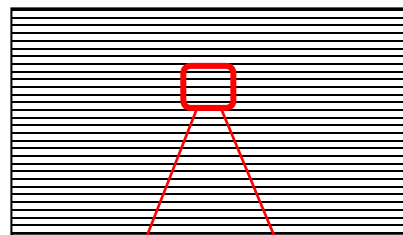

C. Black Pattern

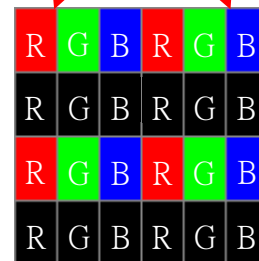

Fig. 3.2 Test patterns

### 3.2 LVDS Characteristics

Parameter		Symbol	Value			Unit	Note
			Min.	Typ.	Max.		
LVDS Interface	Differential Input High Threshold Voltage	$V_{TH}$	+ 100	-	-	mV	(1)
	Differential Input Low Threshold Voltage	$V_{TL}$	-	-	- 100	mV	
	Common Input Voltage	$V_{CM}$	1.0	1.2	1.4	V	
	Differential Input Voltage	$ V_{ID} $	200	400	600	mV	
	Terminating Resistor	$R_T$	-	100	-	ohm	
CMOS Interface	Input High Threshold Voltage	$V_{IH}$	2.7	-	3.3	V	
	Input Low Threshold Voltage	$V_{IL}$	0.0	-	0.7	V	

Note:

(1) The LVDS input signal has been defined as follows:

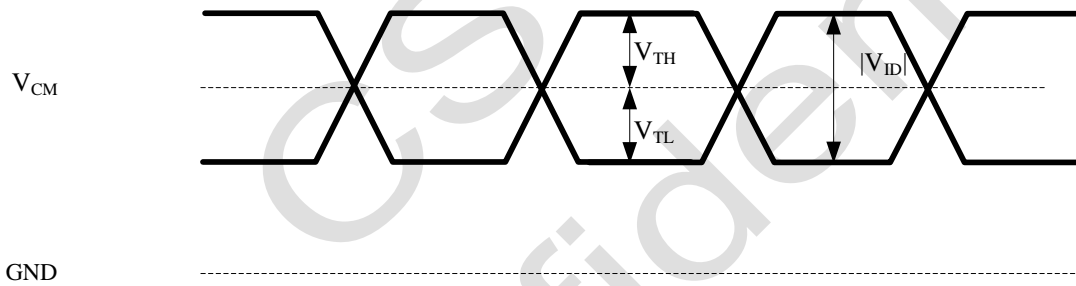

Fig. 3.3 LVDS input signal

## 4. Input Terminal Pin Assignment

### 4.1 Interface pin assignment

CN1: 300C51-0000RA-G4 (STARCONN) or equivalent (see Note (1))

Pin No.	Symbol	Description	Note
1	12V	DC power supply	
2	12V	DC power supply	
3	12V	DC power supply	
4	12V	DC power supply	
5	12V	DC power supply	
6	NC	No Connection	
7	GND	Ground	
8	GND	Ground	
9	GND	Ground	
10	RO[0]N	Odd LVDS Signal -	
11	RO[0]P	Odd LVDS Signal +	
12	RO[1]N	Odd LVDS Signal -	
13	RO[1]P	Odd LVDS Signal +	
14	RO[2]N	Odd LVDS Signal -	
15	RO[2]P	Odd LVDS Signal +	
16	GND	Ground	
17	ROCLK-	Odd LVDS Clock -	
18	ROCLK+	Odd LVDS Clock +	
19	GND	Ground	
20	RO[3]N	Odd LVDS Signal -	
21	RO[3]P	Odd LVDS Signal +	
22	NC	No Connection	
23	NC	No Connection	
24	GND	Ground	
25	RE[0]N	Even LVDS Signal -	
26	RE[0]P	Even LVDS Signal +	
27	RE[1]N	Even LVDS Signal -	
28	RE[1]P	Even LVDS Signal +	
29	RE[2]N	Even LVDS Signal -	
30	RE[2]P	Even LVDS Signal +	
31	GND	Ground	
32	ROCLK-	Even LVDS Clock -	
33	ROCLK+	Even LVDS Clock +	



34	GND	Ground	
35	RE[3]N	Even LVDS Signal -	
36	RE[3]P	Even LVDS Signal +	
37	NC	No Connection	
38	NC	No Connection	
39	GND	Ground	
40	NC	No Connection	
41	NC	No Connection	
42	NC	No Connection	
43	NC	No Connection	
44	NC	No Connection	
45	LVDS_SEL	LVDS Data Format Selection	(3)
46	NC	No Connection	(2)
47	NC	No Connection	(2)
48	NC	No Connection	(2)
49	NC	No Connection	(2)
50	NC	No Connection	(2)
51	NC	No Connection	(2)

Note:

- (1) The direction of pin assignment is shown as below:

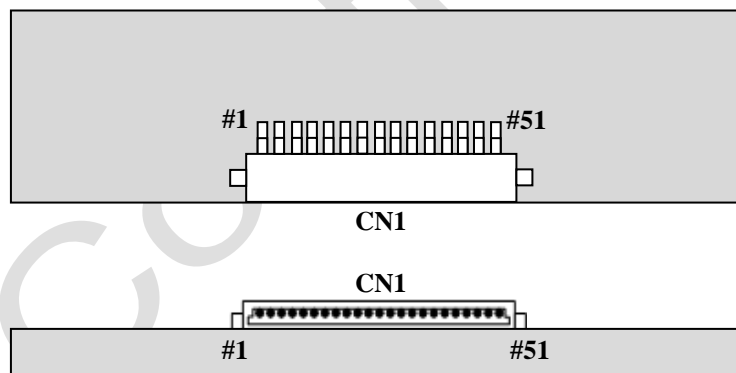
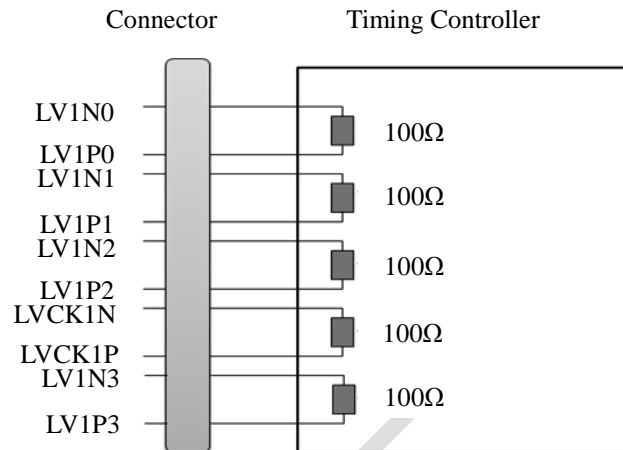

Fig. 4.1 LVDS connector direction sketch map

- (2) For CSOT internal only, please let it open.  
 (3) High: connect to + 3.3 V → VESA format; Low: connect to GND or Open → JEIDA format.

## 4.2 Block Diagram of Interface



Attention:

- (1) This open cell uses a 100 ohms ( $\Omega$ ) resistor between positive and negative lines of each receiver input.
- (2) LVDS cable impedance shall be 50 ohms per signal line or about 100 ohms per twist-pair line respectively.

## 4.3 LVDS Interface

### 4.3.1 VESA Format (SELLVDS = H)

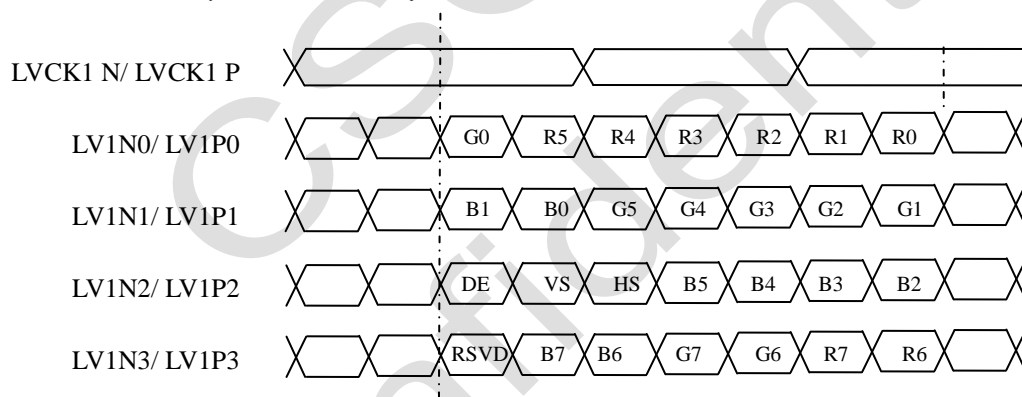

### 4.3.2 JEIDA Format (SELLVDS = L or Open)

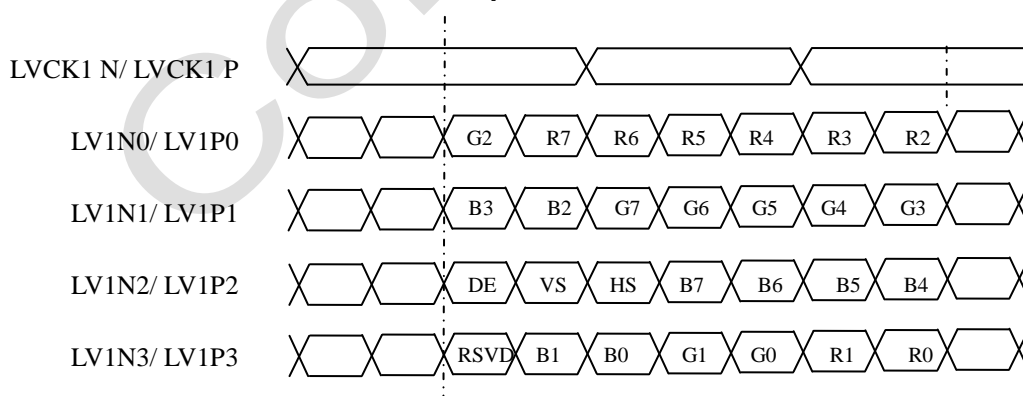

#### 4.4 Pattern FOR Vcom Adjustment

Dot - inversion pattern

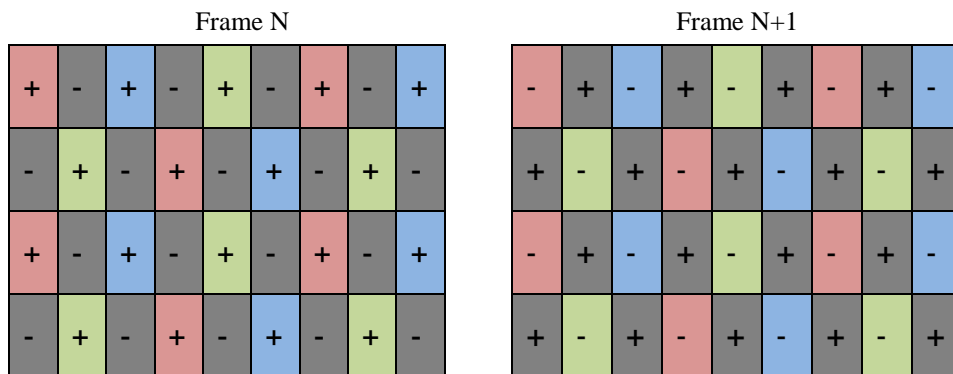

## 5. Interface Timing

### 5.1 Timing Table (DE Only Mode)

Signal	Item	Symbol	Min.	Typ.	Max.	Unit	Note
LVDS Clock	Frequency	$F_{clk}$ ( $= 1 / T_{clk}$ )	50.0	74.25	82.0	MHz	
Vertical Term	Frame Rate	F	47	60	63	Hz	
	Vertical Frequency	$F_v$	60.0	67.5	73.0	KHz	
	Total	$T_v$	1090	1125	1480	$T_h$	$T_v = T_{vd} + T_{vb}$
	Display	$T_{vd}$	1080				
	Blank	$T_{vb}$	10	45	400	$T_h$	
Horizontal Term	Total	$T_h$	1030	1100	1325	$T_{clk}$	$T_h = T_{hd} + T_{hb}$
	Display	$T_{hd}$	960				
	Blank	$T_{hb}$	70	140	365	$T_{clk}$	

Attention:

(1) The TFT LCD Open cell is operated in DE only mode, H sync and V sync input signal have no effect on normal operation.

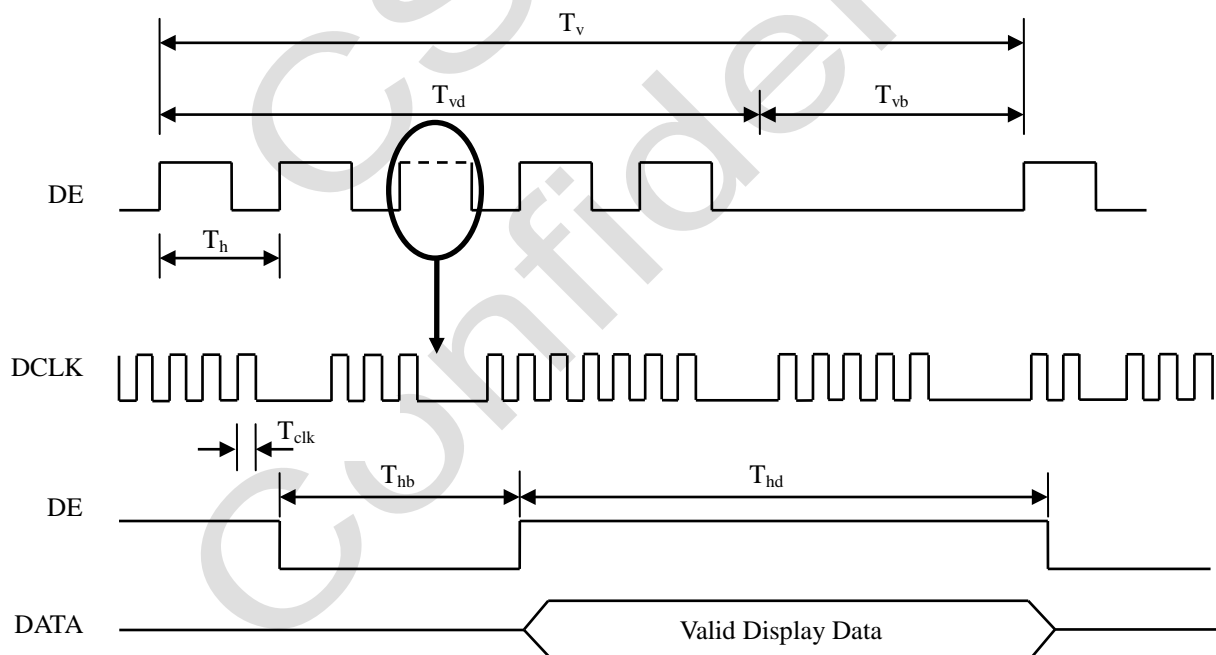

Fig. 5.1 Interface signal timing diagram

## 5.2 Power On/Off Sequence

To prevent a latch-up or DC operation of the Open cell, the power on/off sequence should be as the diagram below.

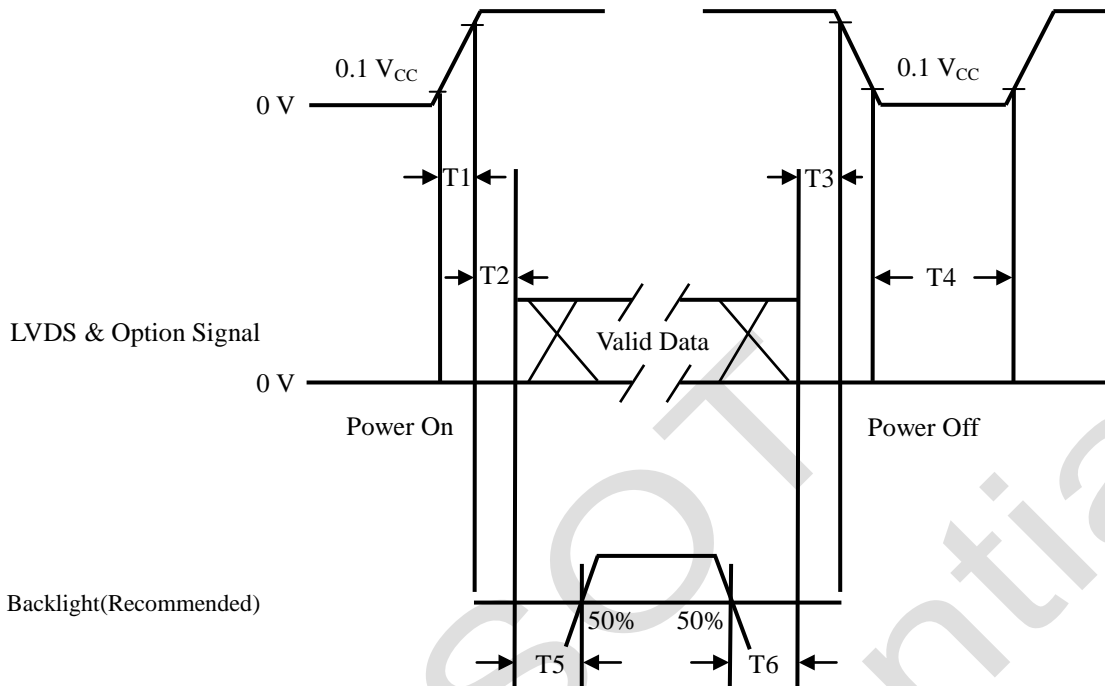

Fig. 5.2 Power On/Off

Parameter	Values			Unit
	Min.	Typ.	Max.	
T1	0.5	-	10	ms
T2	0	-	50	ms
T3	0	-	50	ms
T4	1000	-	-	ms
T5	500	-	-	ms
T6	100	-	-	ms

### Attention:

- (1) The supply voltage of the external system for the open cell input should follow the definition of  $V_{CC}$ .
- (2) When the customer's backlight turns on before the LCD operation or the LCD turns off before the backlight turns off, the display may momentarily become abnormal screen.
- (3) In case that  $V_{CC}$  is in off level, please keep the level of input signals on the low or high impedance. If  $T2 < 0$ , that may cause electrical overstress.
- (4) T4 should be measured after the module has been fully discharged between power off and on period.
- (5) Interface signal shall not be kept at high impedance when the power is on.

## 6. Optical Characteristics

### 6.1 Measurement Conditions

The table below is the test condition of optical measurement.

Item	Symbol	Value	Unit
Ambient Temperature	$T_A$	$25 \pm 2$	$^{\circ}\text{C}$
Ambient Humidity	$H_A$	$50 \pm 10$	% RH
Supply Voltage	$V_{CC}$	12	V
Driving Signal	Refer to the typical value in Chapter 3: Electrical Specification		
Vertical Refresh Rate	$F_R$	60	Hz

To avoid abrupt temperature change during optical measurement, it's suggested to warm up the LCD module more than 45 minutes after lighting the backlight and in the windless environment.

To measure the LCD cell, it is suggested to set up the standard measurement system as Fig. 6.1. The measuring area  $S$  should contain at least 500 pixels of the LCD cell as illustrated in Fig.6.2 ( $A$  means the area allocated to one pixel). In this model, for example, the minimum measuring distance  $Z$  is 370 mm when  $\theta$  is 2 degree. Hence, 500 mm is the typical measuring distance. This measuring condition is referred to 301-2H of VESA FPDM 2.0 about viewing distance, angle, and angular field of view definition.

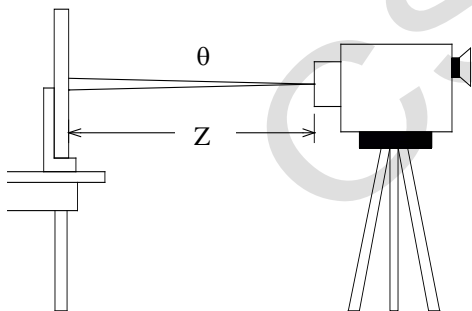

Fig. 6.1 The standard set-up system of measurement

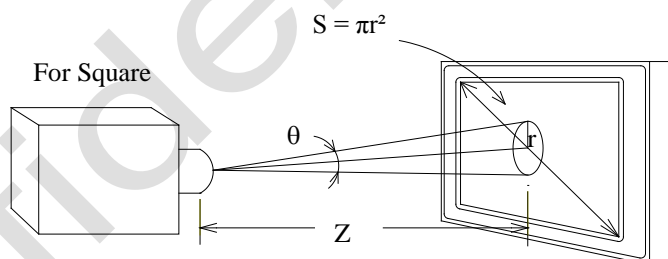

Fig. 6.2 The area  $S$  contains at least 500 pixels to be measured

$$N = \frac{S}{A} \geq 500\text{pixels}$$

$N$  means the actual number of the pixels in the area  $S$ .

## 6.2 Optical Specifications

The table below of optical characteristics is measured by MINOLTA CS2000, MINOLTA CA310, ELDIM OPTI Scope-SA and ELDIM EZ Contrast in dark room.

Item		Symbol	Condition	Min.	Typ.	Max.	Unit	Note
Static Contrast Ratio		CR	$\theta_H = 0^\circ, \theta_V = 0^\circ$ Normal direction at center point with CSOT's module: MT4601B02-1	-	4000	-	-	(1) (2)
Response Time		$T_L$		-	6.5	12	ms	(3)
Center Transmittance		T%		-	5.9		%	(2) (4)
Color Chromaticity (CIE1931)	Red	$R_X$		Typ. - 0.03	TBD	Typ. + 0.03	-	(2) (5)
		$R_Y$			TBD		-	
	Green	$G_X$			TBD		-	
		$G_Y$			TBD		-	
	Blue	$B_X$			TBD		-	
		$B_Y$			TBD		-	
	White	$W_X$			0.280		-	
		$W_Y$	0.290		-			
Color Gamut		CG	68	72	-	% NTSC		
Viewing Angle	Horizontal	$\theta_{H+}$	-	89	-	Deg.	(6)	
		$\theta_{H-}$	-	89	-			
	Vertical	$\theta_{V+}$	-	89	-			
		$\theta_{V-}$	-	89	-			

Note:

(1) Definition of static contrast ratio (CR):

It's necessary to switch off all the dynamic and dimming function when measuring the static contrast ratio.

$$\text{Static Contrast Ratio (CR)} = \frac{\text{CR-W}}{\text{CR-D}}$$

CR-W is the luminance measured by LMD (light-measuring device) at the center point of the LCD module with full-screen displaying white. The standard setup of measurement is illustrated in Fig. 6.3; CR-D is the luminance measured by LMD at the center point of the LCD module with full-screen displaying black. The LMD in this item is CS2000.

(2) The LMD in the item could be a spectroradiometer such as (KONICA MINOLTA) CS2000, CS1000(TOPCON), SR-UL2 or the same level spectroradiometer. Other display color analyzer (KONICA MINOLTA) CA210, CA310 or (TOPCON) BM-7 could be involved after being calibrated with a spectroradiometer on each stage of a product.

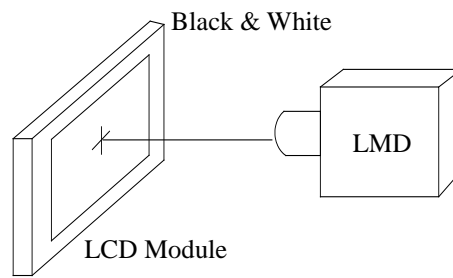
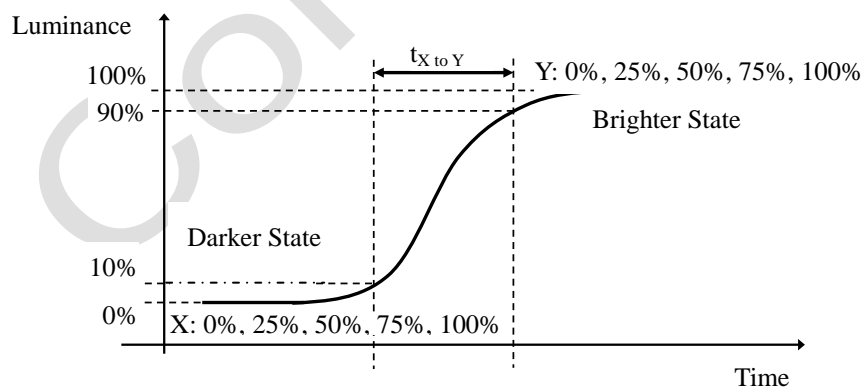

Fig. 6.3 The standard setup of CR measurement

(3) Response time  $T_L$  is defined as the average transition time in the response time matrix. The table below is the response time matrix in which each element  $t_{X \text{ to } Y}$  is the transition time from luminance ratio  $X$  to  $Y$ .  $X$  and  $Y$  are two different luminance ratios among 0%, 25%, 50%, 75%, and 100% luminance. The transition time  $t_{X \text{ to } Y}$  is defined as the time taken from 10% to 90% of the luminance difference between  $X$  and  $Y$  ( $X < Y$ ) as illustrated in Fig.6.4. When  $X > Y$ , the definition of  $t_{X \text{ to } Y}$  is the time taken from 90% to 10% of the luminance difference between  $X$  and  $Y$ . The response time is optimized on refresh rate  $F_r = 60\text{Hz}$ .

Measured Transition Time		Luminance Ratio of Previous Frame				
		0%	25%	50%	75%	100%
Luminance Ratio of Current Frame	0%		$t_{25\% \text{ to } 0\%}$	$t_{50\% \text{ to } 0\%}$	$t_{75\% \text{ to } 0\%}$	$t_{100\% \text{ to } 0\%}$
	25%	$t_{0\% \text{ to } 25\%}$		$t_{50\% \text{ to } 25\%}$	$t_{75\% \text{ to } 25\%}$	$t_{100\% \text{ to } 25\%}$
	50%	$t_{0\% \text{ to } 50\%}$	$t_{25\% \text{ to } 50\%}$		$t_{75\% \text{ to } 50\%}$	$t_{100\% \text{ to } 50\%}$
	75%	$t_{0\% \text{ to } 75\%}$	$t_{25\% \text{ to } 75\%}$	$t_{50\% \text{ to } 75\%}$		$t_{100\% \text{ to } 75\%}$
	100%	$t_{0\% \text{ to } 100\%}$	$t_{25\% \text{ to } 100\%}$	$t_{50\% \text{ to } 100\%}$	$t_{75\% \text{ to } 100\%}$	

$t_{X \text{ to } Y}$  means the transition time from luminance ratio  $X$  to  $Y$ .

Fig. 6.4 The definition of  $t_{X \text{ to } Y}$ 

All the transition time is measured at the center point of the LCD module by ELDIM OPTI Scope-SA.



## (4) Definition of center Transmittance (T%):

The transmittance is measured with full white pattern (Gray 255)

$$\text{Static Contrast Ratio (CR)} = \frac{\text{Luminance of LCD module}}{\text{Luminance of Backlight}}$$

## (5) Definition of color chromaticity:

Each chromaticity coordinates (x, y) are measured in CIE1931 color space when full-screen displaying primary color R, G, B and white. The color gamut is defined as the fraction in percent of the area of the triangle bounded by R, G, B coordinates and the area is defined by NTSC 1953 color standard in the CIE color space. Chromaticity coordinates are measured by CS2000 and the standard setup of measurement is shown in Fig. 6.5.

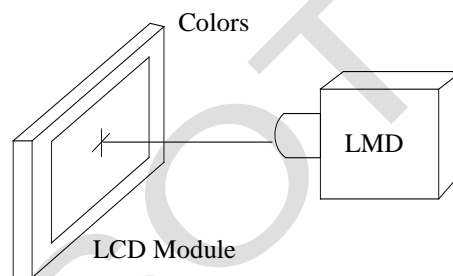

Fig. 6.5 The standard setup of color chromaticity measurement

(6) Definition of viewing angle coordinate system ( $\theta_H$ ,  $\theta_V$ ):

The contrast ratio is measured at the center point of the LCD module. The viewing angles are defined at the angle that the contrast ratio is larger than 10 at four directions relative to the perpendicular direction of the LCD module (two vertical angles: up  $\theta_{V+}$  and down  $\theta_{V-}$ ; and two horizontal angles: right  $\theta_{H+}$  and left  $\theta_{H-}$ ) as illustrated in Fig. 6.6. The contrast ratio is measured by ELDIM EZ Contrast.

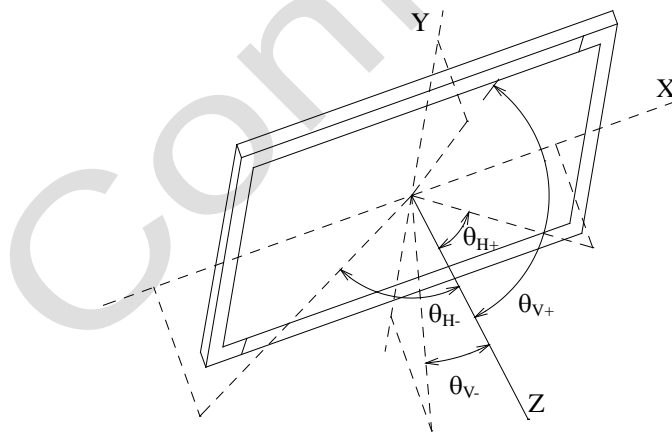
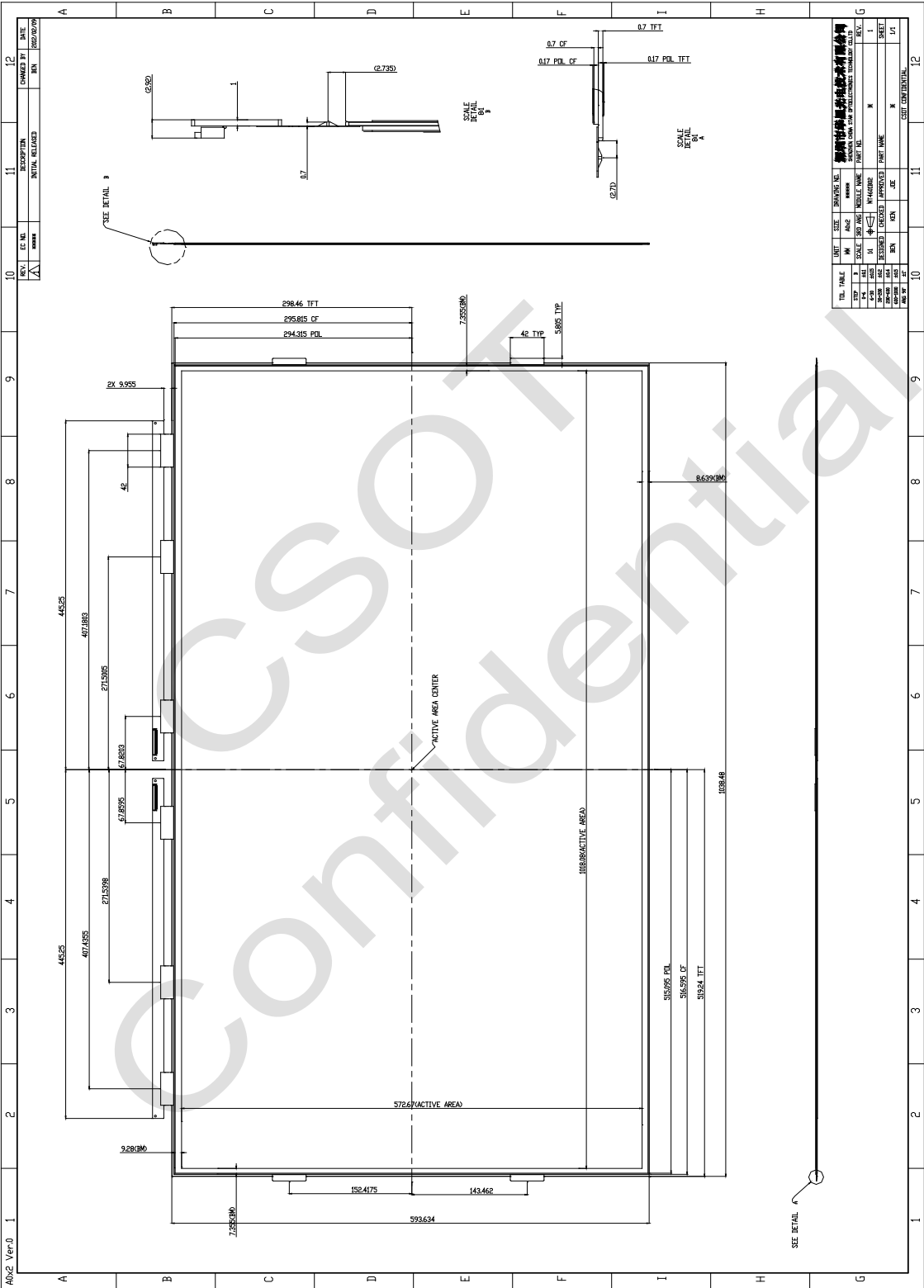

Fig. 6.6 Viewing angle coordination system

# 7. Mechanical Characteristics

## 7.1 Mechanical Specification



## 7.2 Packing

### 7.2.1 Packing Specifications

Item	Specification		
	Quantity	Dimension (mm)	Weight (kg)
Packing Box	12 pcs / box	1243(L) x 796 (W) x 200 (H)	Net Weight: 28.20 (Max.) Gross Weight: 44.70 (Max.)
Pallet	1	1300.00 (L) x 1100.00 (W) x 150.00 (H)	Net Weight: 14.8
Stack Layer	4		
Boxes per Pallet	8 boxes / pallet		
Pallet after Packing	96 pcs / pallet	1300.0 (L) x 1100.0 (W) x 950.0 (H)	Gross Weight:372.4kg / pallet

### 7.2.2 Packing Method

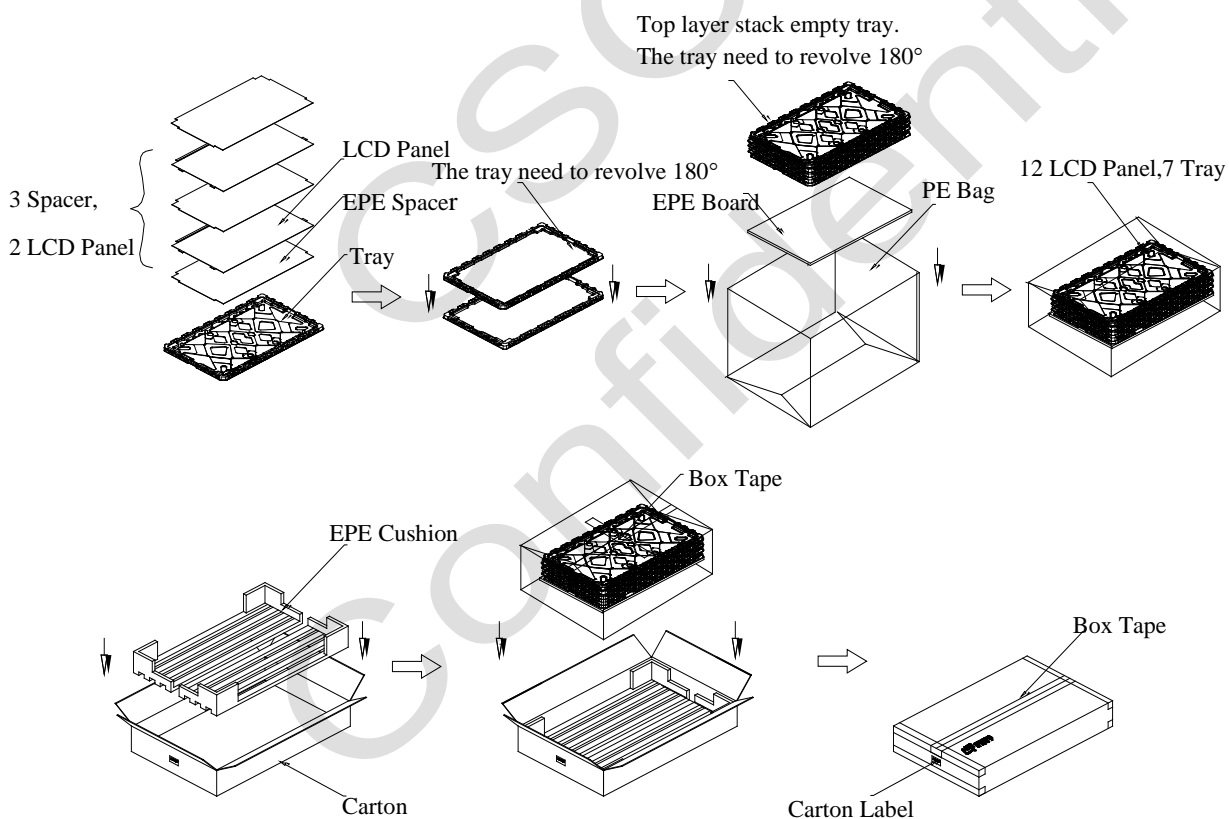

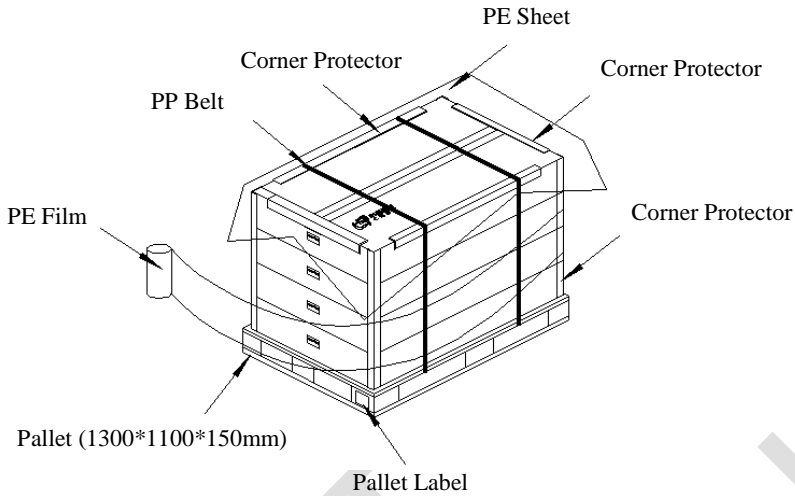

**8. Definition of Labels**  
**8.1 Open Cell Label**



Model Name: ST4601B02-1

Ver.X.X: Version, for example: 0.1, 0.2, ... , 1.1, 1.2, ..., 2.1, 2.2, ...

WC (Week Code): XX XX

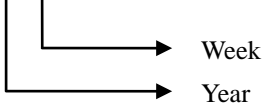

Year: 2010 = 10, 2011 = 11 ... 2020 = 20, 2021 = 21...

Week: 01, 02, 03 ...

Serial Number: XXXXXXXXXXXXXXXX XXXXXXXXX

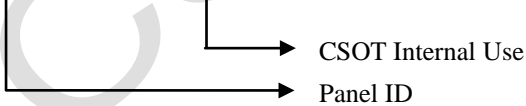

8.2 Carton Label



For RoHS compliant products, CSOT will add RoHS for identification.

Serial Number: XXXX XX XXXXXX XXXXXX

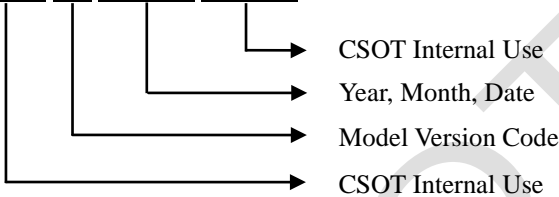

Manufactured Date:

- Year: 2010 = 10, 2011 = 11...2020 = 20, 2021 = 21...
- Month: 1~9, A~C, for Jan. ~ Dec.
- Date: 01~31, for 1st to 31st

Model Version Code: Version of product, for example: 01, 02, 11, 12...

8.3 Pallet Label



Serial Number: XXX XX XXX XXXXXX

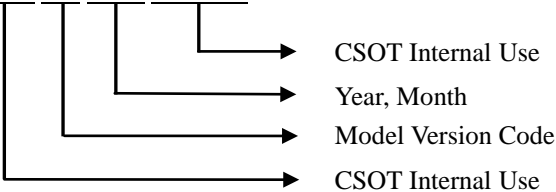

## 9. Precautions

### 9.1 Assembly and Handling Precautions

- (1) Do not apply rough force such as bending or twisting to the open cell during assembly.
- (2) It is recommended to assemble or install a open cell into the user's system in clean working areas. The dust and oil may cause electrical short or damage the polarizer.
- (3) Do not apply pressure or impulse to the open cell to prevent the damage to the open cell.
- (4) Always follow the correct power-on sequence. This can prevent the damage and latch-up to the LSI chips.
- (5) Do not plug in or pull out the interface connector while the open cell is in operation.
- (6) Use soft dry cloth without chemicals for cleaning because the surface of polarizer is very soft and easily be scratched.
- (7) Moisture can easily penetrate into the open cell and may cause the damage during operation.
- (8) High temperature or humidity may deteriorate the performance of the open cell. Please store open cell in the specified storage conditions.
- (9) When ambient temperature is lower than 10 °C, the display quality might be deteriorated. For example, the response time will become slow.

### 9.2 Safety Precautions

- (1) If the liquid crystal material leaks from the panel, it should be kept away from the eyes or mouth. In case of contact with hands, skin or clothes, it has to be washed away thoroughly with soap.
- (2) After the open cell end of life, it is not harmful in case of normal operation and storage.