



MODEL: ST5461D07-1

Ver. : 2.1

Date: 30.Nov.2016

Customer's Approval	CSOT
Signature _____ Date _____	Approved By Product Director Date _____ Name: CT Chen Signature: _____
	Reviewed By PM Manager Date _____ Name: Lin Xu Signature: _____
	Reviewed By Project Leader Date _____ Name: Wei jung Chiu Signature: _____
	Reviewed By PM Date _____ Name: Nuan Yin Signature: _____

Contents

1. General Description	5
1.1 Product Features	5
1.2 Overview.....	5
1.3 General Information.....	5
2. Absolute Maximum Ratings	6
2.1 Absolute Maximum Ratings ($T_a = 25 \pm 2 \text{ }^\circ\text{C}$).....	6
2.2 Environment Requirement.....	6
2.3 Package Storage.....	6
3. Electrical Specification.....	7
3.1 Electrical Characteristics	7
3.1.1 Power Consumption ($T_a = 25 \pm 2 \text{ }^\circ\text{C}$).....	7
3.1.2 V by One Characteristic.....	8
3.1.3 V by One Input Signal Timing.....	9
3.1.4 Driver IC ESD spec	10
4. Input Terminal Pin Assignment	11
4.1 Interface Pin Assignment.....	11
4.2 VCOM Adjustment.....	13
4.3 Block Diagram of Interface	15
4.3.1 TFT LCD Panel.....	15
4.4 4K2K Data Format.....	16
4.5 Color Data Input Assignment	17
5. V-by-One Each Lane Timing Spec	18
5.1 Timing Table (DE Only Mode).....	18
5.2 Power On/Off Sequence	20
6. Optical Characteristics.....	22
6.1 Measurement Conditions	22
6.2 Optical Specifications	23
7. Mechanical Characteristics	28
7.1 Mechanical Specification.....	28
7.2 Packing.....	28
7.2.1 Packing Specifications	29
7.2.2 Packing Method	29
8. Definition of Labels	30
8.1 Open Cell Label.....	30
8.2 Carton Label	30

8.3 Pallet Label31

9. Precautions.....32

9.1 Assembly and Handling Precautions32

9.2 Safety Precautions.....32

CSOT
Confidential

Revision History

Version	Date	Page (New)	Section	Description	Revision by
Ver. 2.1	30.Nov..2016	All	All	Final Specification was First Issued.	Yin nuan

CSOT
Confidential

1. General Description

1.1 Product Features

- **QFHD Resolution (3840 x 2160)**
- **Very High Contrast Ratio:4500:1**
- **Fast Response Time**
- **High Color Saturation: 72% NTSC**
- **Ultra Wide Viewing Angle: 178° (H)/178° (V)(CR≥10)**
- **DE (Data Enable) Mode**
- **V by One Interface**

1.2 Overview

ST5461D07-1 is a diagonal 54.6" color active matrix open cell with 8 lanes V by one interface. This open cell is a transmissive type display operating in the normally black mode. It supports 3840x2160 QFHD resolution and can display up to 1.07G colors (8bit+FRC). Each pixel is divided into Red, Green and Blue sub-pixels which are arranged in vertical stripe.

This open cell dedicates for LCD TV products and provides excellent performance which includes high brightness, ultra wide viewing angle, high color saturation and high color depth. CSOT open cell comply with ROHS for identification.

1.3 General Information

Item	Specification	Unit	Note
Active Area	1209.6 (H)x680.4 (V)	mm	
Cell Size	1225.2(H)x 696.7(V)	mm	
Weight	2.65	kg	Max.
Driving Scheme	a-Si TFT Active Matrix	-	
Number of Pixels	3840x2160	pixel	
Pixel Pitch (Sub Pixel)	0.105(H)x 0.315(V)	mm	
Pixel Arrangement	RGB Vertical Stripe	-	
Display Colors	1.07G	color	8bit+FRC
Display Mode	Transmissive Mode, Normally Black	-	
Glass Thickness (Array/CF)	0.5/0.5	mm	
Color Chromaticity	Red (0.633,0.335) Green (0.300,0.628) Blue (0.153,0.065) White (0.275,0.303)		Typical value measured at CSOT's module BLU: MT5461D01-3
Contrast Ratio	4500:1(Typ.)		
Cell Transmittance	5.4 (Typ.)	%	
View Angle(CR>10)	178 °(H)/178 °(V)		
Surface Treatment	Anti-Glare, Haze 2%, Hard Coating(3H)		

2. Absolute Maximum Ratings

2.1 Absolute Maximum Ratings ($T_a = 25 \pm 2 \text{ }^\circ\text{C}$)

The followings are maximum values which, if exceeded, may cause damage to the unit.

Item	Symbol	Value		Unit
		Min.	Max.	
Power Supply Voltage	V_{CC}	-0.3	13.5	V
Input Signal Voltage	V_{IN}	-0.3	3.6	V

2.2 Environment Requirement

(1) Temperature and relative humidity range are shown as below

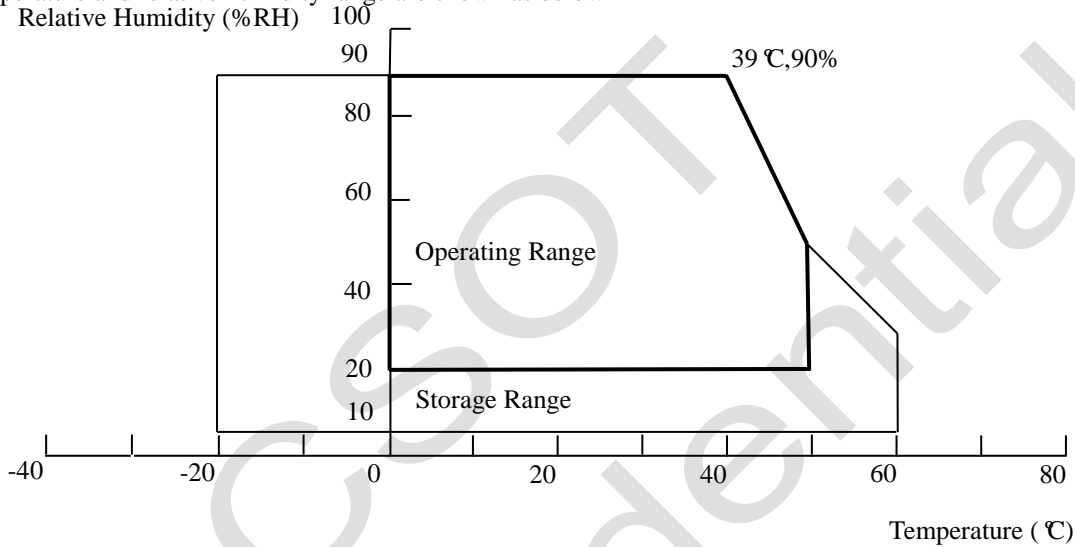

Fig. 2.1 Operating and storage environment

- (a) 90%RH maximum ($T_a \leq 39 \text{ }^\circ\text{C}$).
- (b) Wet-bulb temperature should be 39 °C maximum ($T_a > 39 \text{ }^\circ\text{C}$).
- (c) No condensation.

(2) The storage temperature is between $-20 \text{ }^\circ\text{C}$ to $60 \text{ }^\circ\text{C}$, and the operating ambient temperature is between $0 \text{ }^\circ\text{C}$ to $50 \text{ }^\circ\text{C}$.

The maximum operating temperature is based on the test condition that the surface temperature of display area is less than or equal to $65 \text{ }^\circ\text{C}$ with LCD module in a temperature controlled chamber alone. Thermal management should be considered in final product design to prevent the surface temperature of display area from being over $65 \text{ }^\circ\text{C}$. The range of operating temperature may degrade in case of improper thermal management in the end product design.

(3) The rating of environment is based on LCD module. Leave LCD cell alone, this environment condition can't be guaranteed.

Except LCD cell, the customer has to consider the ability of other parts of LCD module and LCD module process.

2.3 Package Storage

When storing open cell as spares for a long time, please follow the precaution instructions:

- (1) Do not store the open cell in high temperature and high humidity for a long time. It is highly recommended to store the module with temperature from $20 \text{ }^\circ\text{C}$ to $30 \text{ }^\circ\text{C}$ in normal humidity ($50 \pm 10\% \text{ RH}$) with shipping package.
- (2) The open cell should be kept within one month shelf life.

3. Electrical Specification

3.1 Electrical Characteristics

3.1.1 Power Consumption ($T_a = 25 \pm 2^\circ\text{C}$)

Parameter		Symbol	Value			Unit	Note
			Min.	Typ.	Max.		
Power Supply Voltage		V_{CC}	10.8	12.0	13.2	V	(1)
Rush Current		I_{RUSH}	-	-	3.80	A	(2)
Power Supply Current	White Pattern	I_{cc}	-	1.97	2.925	A	(3)
	Horizontal Stripe	I_{cc}	-	1.99	2.873	A	
	Black Pattern	I_{cc}	-	0.66	0.95	A	

Note:

(1)The ripple voltage should be controlled less than 10% of V_{CC} .

(2)Measurement condition: V_{CC} rising time=470 μs .

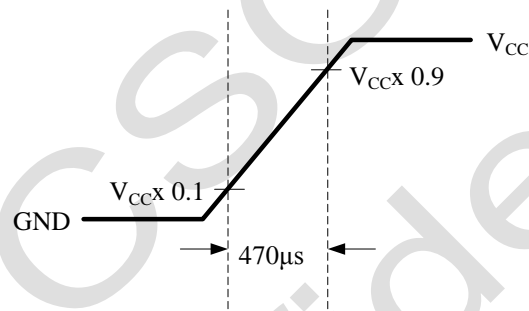

Fig. 3.1 V_{CC} rising time condition

(3)Measurement condition: $V_{CC}=12\text{V}$, $T_a = 25 \pm 2^\circ\text{C}$, $F = 60\text{Hz}$. The test patterns are shown as below.

A. White Pattern



B. Horizontal Pattern

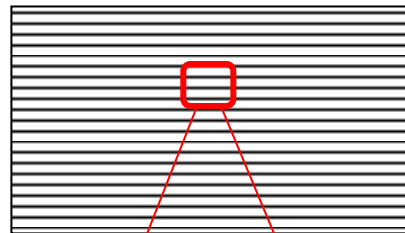

C. Black Pattern

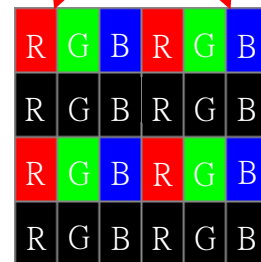

Fig. 3.2 Test patterns

3.1.2 V by One Characteristic

Parameter		Symbol	Value			Unit	Note
			Min.	Typ.	Max.		
V by one Interface	Differential Input High Threshold Voltage	V_{TH}	-	-	+50	mV	
	Differential Input Low Threshold Voltage	V_{TL}	-50	-	-	mV	
	Intra-pair Skew	TTOSK_intra	-0.3	-	0.3	UI	(1)
	Inter-pair Skew	TTOSK_inter	-5	-	5	UI	(2)
	Spread Spectrum Modulation range	30KHz modulation	-0.5		+0.5	%	(3)
	Differential Input Swing Voltage	V	200		400	mV	
CMOS Interface	Input High Threshold Voltage	V_{IH}	2.4	-	3.3	V	
	Input Low Threshold Voltage	V_{IL}	0	-	0.6	V	

Note:

(1) Intra-pair skew

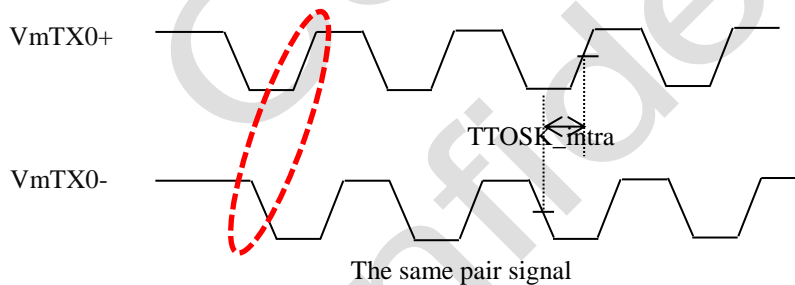

Fig. 3.3 V by one Intra-pair skew

(2) Inter-pair skew

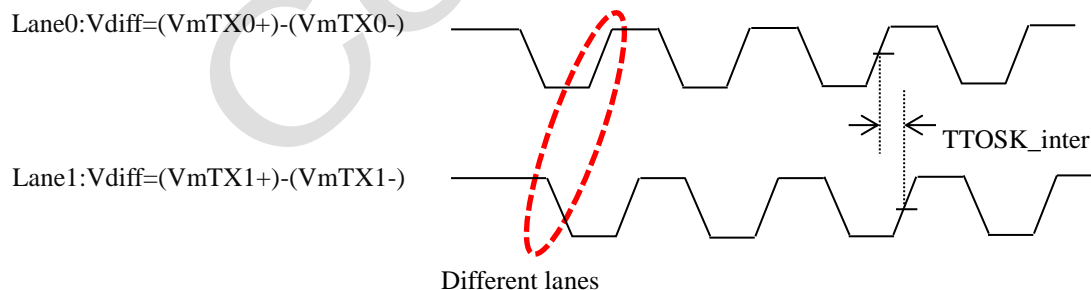

Fig. 3.4 V by one Inter-pair skew

(3) The V by one SSM's suggestion is off by default, SOC board must test all validations if SOC board enable the V by one SSM.

3.1.3 V by One Input Signal Timing

Item	X(UI)	Y(mV)	Note
A	0.25	0	(1)
B	0.3	50	(1)
C	0.7	50	(1)
D	0.75	0	(1)
E	0.7	-50	(1)
F	0.3	-50	(1)

Note:
(1)

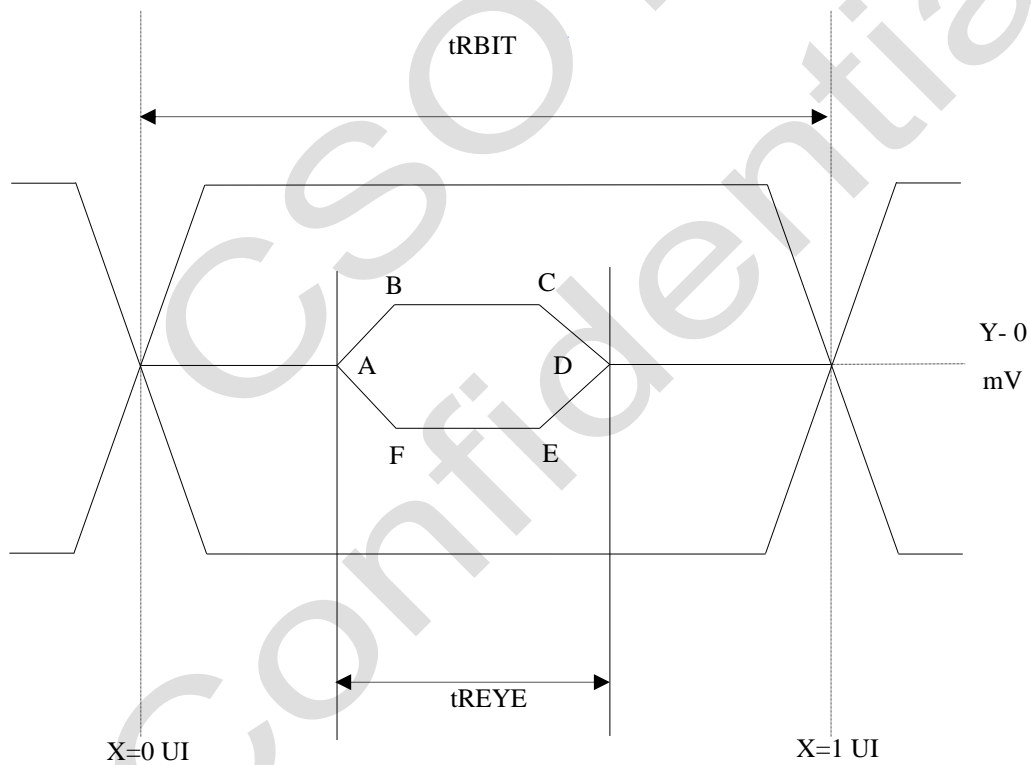

Fig. 3.5 V by one input signal timing

3.1.4 Driver IC ESD spec

The Electro-Static Discharge tolerance of Source COF IC and Gate COF IC is $\pm 2\text{KV}$ tested by ESD Gun. Especially if the LCD module is designed with the Plastic Bezel, we suggest ESD protection solutions should be applied to avoid damaged, as shown in Fig.3.6 and Fig.3.7.

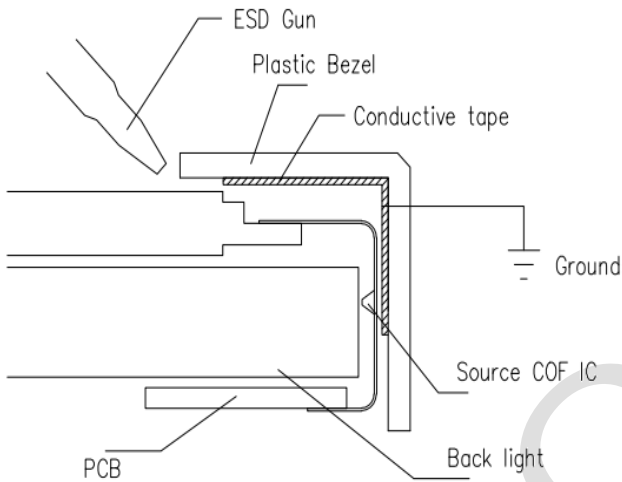

Fig. 3.6 Source COF IC ESD protection

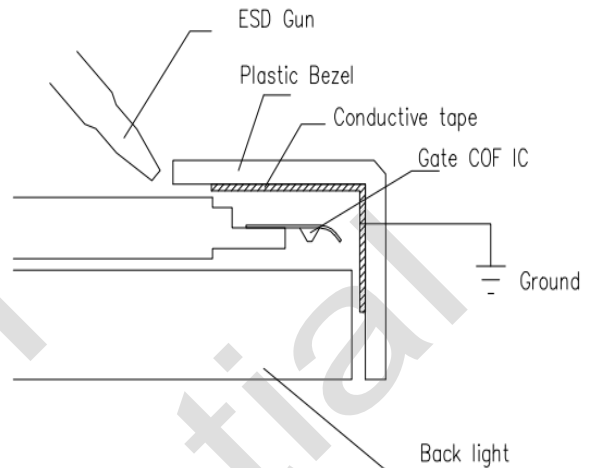

Fig. 3.7 Gate COF IC ESD protection

3.2 Temperature spec

Parameter	Symbol	SPEC			Unit	Recommend test pattern	Note
		Min.	Typ.	Max.			
Surface temperature	T_{TCON}	-	-	85	°C	White Pattern	(1)
	T_{PMIC}			85		White Pattern	(1)
	T_{Driver}	-	-	115		White Pattern	(1)

Note:

Any point on the IC surface must be less than maximum spec under any conditions, If the surface temperature is out of the spec, thermal solutions should be applied to avoid the damage;

4. Input Terminal Pin Assignment

4.1 Interface Pin Assignment

CN1:300C51-C00RA-M3-R (Starconn) or equivalent

Pin No.	Symbol	Description	Note
1	VCC	Power 12V in	
2	VCC	Power 12V in	
3	VCC	Power 12V in	
4	VCC	Power 12V in	
5	VCC	Power 12V in	
6	VCC	Power 12V in	
7	VCC	Power 12V in	
8	VCC	Power 12V in	
9	NC	No Connection	(3)
10	GND	Ground	
11	GND	Ground	
12	GND	Ground	
13	GND	Ground	
14	GND	Ground	
15	NC	No Connection	(3)
16	NC	No Connection	(3)
17	NC	No Connection	(3)
18	SDA	I2C Serial Data (for adjust VCOM)	(2)
19	SCL	I2C Serial Clock (for adjust VCOM)	(2)
20	WP	Write Protect (High: Write Enable ; Low or Open: Write Disable)	(2)
21	NC	No Connection	(3)
22	NC	No Connection	(3)
23	NC	No Connection	(3)
24	GND	Ground	
25	HTPDN	Hot Plug Detect	
26	LOCKN	Lock Detect	
27	GND	Ground	
28	Rx0N	Vx1 Lane0-	
29	Rx0P	Vx1 Lane0+	
30	GND	Ground	

31	Rx1N	Vx1 Lane1-	
32	Rx1P	Vx1 Lane1+	
33	GND	Ground	
34	Rx2N	Vx1 Lane2-	
35	Rx2P	Vx1 Lane2+	
36	GND	Ground	
37	Rx3N	Vx1 Lane3-	
38	Rx3P	Vx1 Lane3+	
39	GND	Ground	
40	Rx4N	Vx1 Lane4-	
41	Rx4P	Vx1 Lane4+	
42	GND	Ground	
43	Rx5N	Vx1 Lane5-	
44	Rx5P	Vx1 Lane5+	
45	GND	Ground	
46	Rx6N	Vx1 Lane6-	
47	Rx6P	Vx1 Lane6+	
48	GND	Ground	
49	Rx7N	Vx1 Lane7-	
50	Rx7P	Vx1 Lane7+	
51	GND	Ground	

(1) The direction of pin assignment is shown as below:

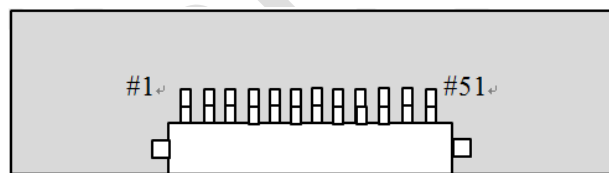

Fig. 4.1.1 Connector direction sketch map

(2) L = Connect to GND, H = Connect to +3.3V

WP	Note
L or Open	Write Disable
H	Write Enable

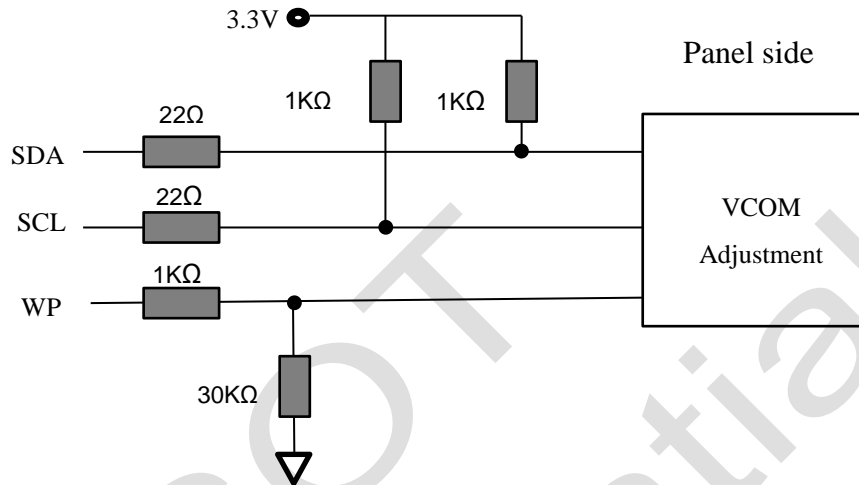

Fig. 4.1.2

(3) This pin is for CSOT use only, please let it open

(4) Always JEIDA mode

4.2 VCOM Adjustment

(a) Flicker should be adjusted by optimizing the Vcom value in customer LCM line through the I2C interface.

(Master & slave = I2C communication)

Pin. NO.	Symbol	Function	Remark
1	TCON_WP	EN	Default:0V Vcom tuning:3.3V (Shouldn't be communicated with I2C device as output level "5V")
2	SCL_I	I2C Interface	I2C Interface
3	SDA_I	I2C Interface	

(b) Flicker should be tuned by correct method according to gamma IC type of each model.

Type	Flicker data saving position	Slave Address							
		B7	B6	B5	B4	B3	B2	B1	B0
	Gamma IC memory	1	1	1	0	1	0	0	R/W-

(c)Flicker should be adjusted the pattern, where are displayed alternately below.

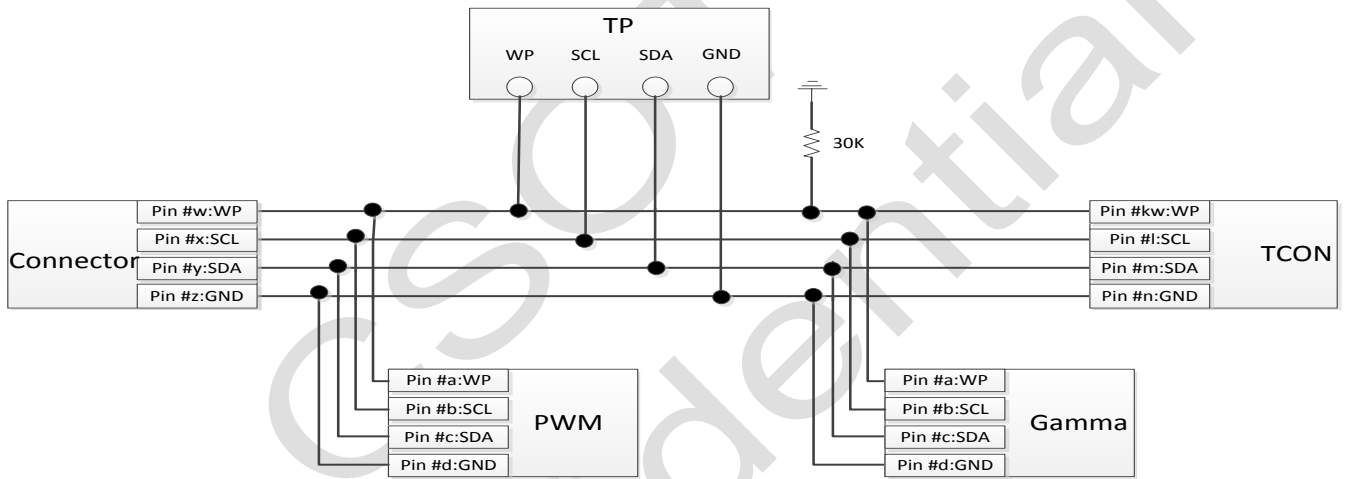
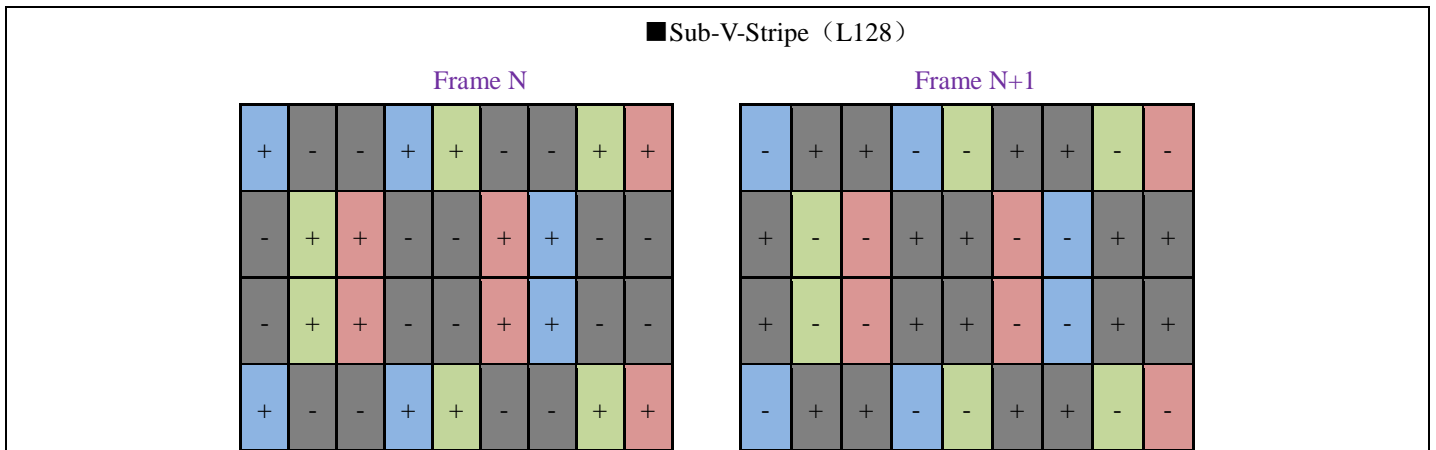
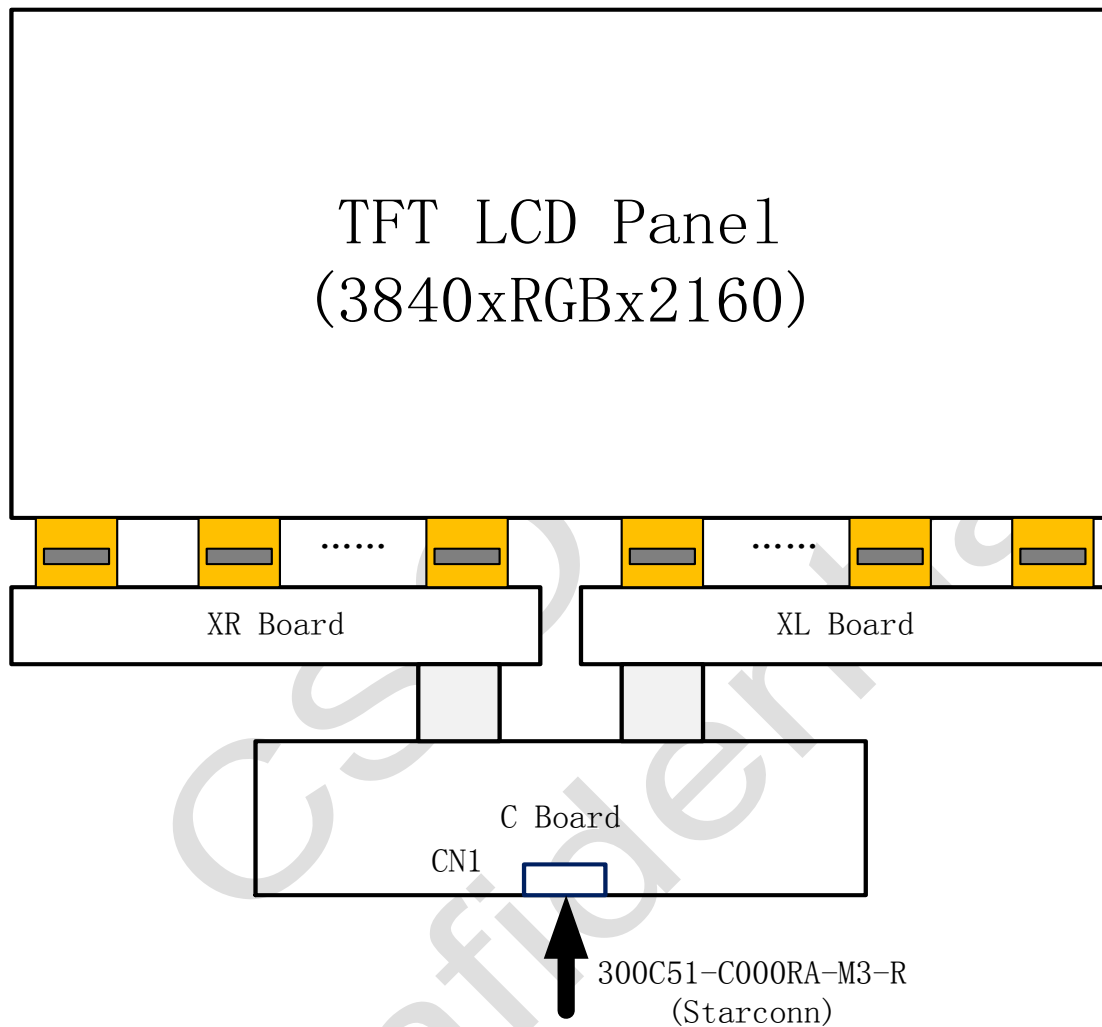

Fig. 4.2 Flicker Adjust Circuit Block Diagram

4.3 Block Diagram of Interface

4.3.1 TFT LCD Panel



4.4 4K2K Data Format

V by One Data Mapping

Area	Lane	Data Stream
Left	Lane 0	Pixel 1, 5, 9,,1913, 1917
	Lane 1	Pixel 2, 6, 10,,1914, 1918
	Lane 2	Pixel 3, 7, 11,,1915, 1919
	Lane 3	Pixel 4, 8, 12,,1916, 1920
Right	Lane 4	Pixel 1921, 1925, 1929,,3833, 3837
	Lane 5	Pixel 1922, 1926, 1930,,3834, 3838
	Lane 6	Pixel 1923, 1927, 1931,,3835, 3839
	Lane 7	Pixel 1924, 1928, 1932,,3836, 3840

2D Mode:

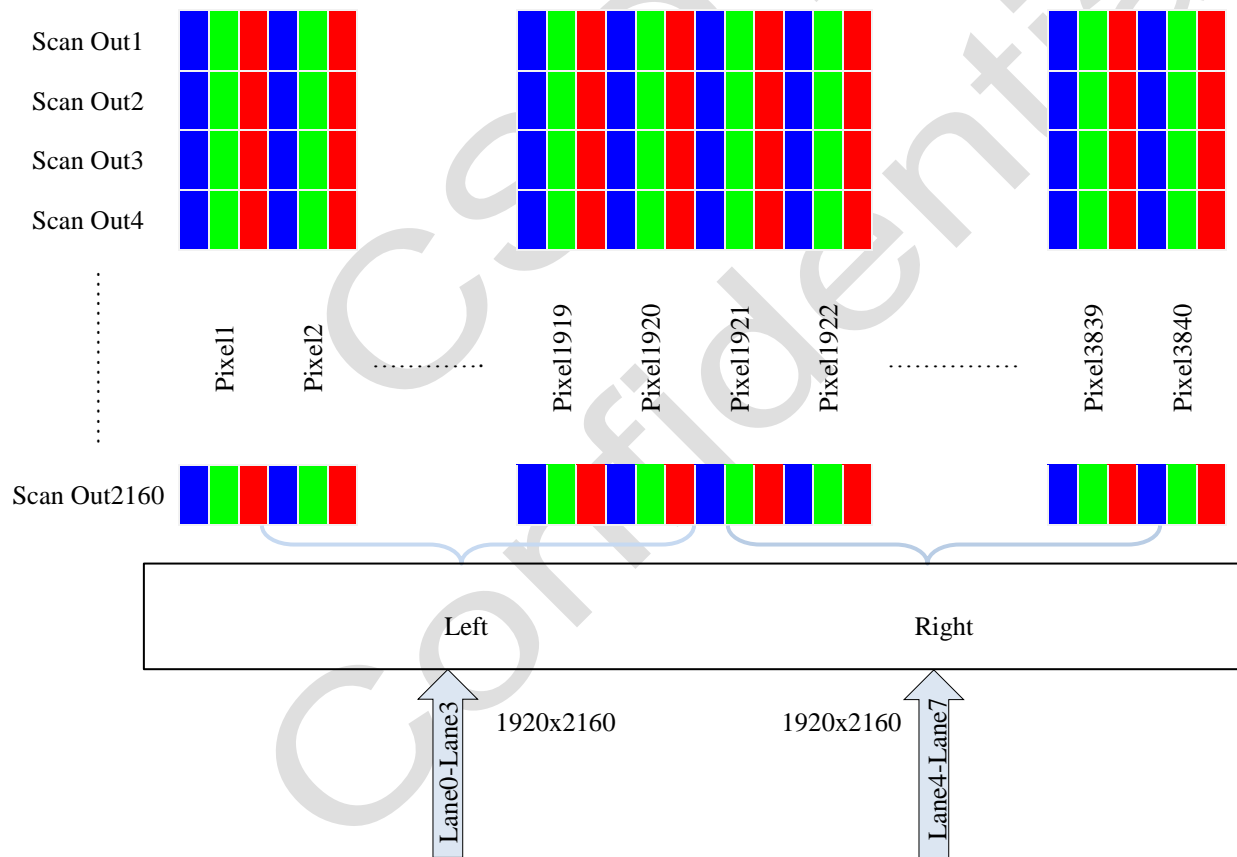

Fig. 4.3 2D data format

4.5 Color Data Input Assignment

The brightness of each primary color is based on the 10-bit gray scale data input for each color. The higher the binary input, the brighter the color. The table below provides the assignment of the color versus.

Data Input Color		Data Signal																														
		Red										Green										Blue										
		MSB					LSB					MSB					LSB					MSBLSB										
		R9	R8	R7	R6	R5	R4	R3	R2	R1	R0	G9	G8	G7	G6	G5	G4	G3	G2	G1	G0	B9	B8	B7	B6	B5	B4	B3	B2	B1	B0	
Basic Colors	Black	0	0	0	0	0	0	0	0	0	0	0	0	0	0	0	0	0	0	0	0	0	0	0	0	0	0	0	0	0	0	0
	Red(1023)	1	1	1	1	1	1	1	1	1	0	0	0	0	0	0	0	0	0	0	0	0	0	0	0	0	0	0	0	0	0	0
	Green(1023)	0	0	0	0	0	0	0	0	0	1	1	1	1	1	1	1	1	1	1	1	0	0	0	0	0	0	0	0	0	0	0
	Blue(1023)	0	0	0	0	0	0	0	0	0	0	0	0	0	0	0	0	0	0	0	0	1	1	1	1	1	1	1	1	1	1	1
	Cyan	0	0	0	0	0	0	0	0	0	1	1	1	1	1	1	1	1	1	1	1	1	1	1	1	1	1	1	1	1	1	1
	Magenta	1	1	1	1	1	1	1	1	1	0	0	0	0	0	0	0	0	0	0	1	1	1	1	1	1	1	1	1	1	1	1
	Yellow	1	1	1	1	1	1	1	1	1	1	1	1	1	1	1	1	1	1	1	0	0	0	0	0	0	0	0	0	0	0	0
	White	1	1	1	1	1	1	1	1	1	1	1	1	1	1	1	1	1	1	1	1	1	1	1	1	1	1	1	1	1	1	1
GrayScale of Red	Red(000)	0	0	0	0	0	0	0	0	0	0	0	0	0	0	0	0	0	0	0	0	0	0	0	0	0	0	0	0	0	0	
	Red(001)	0	0	0	0	0	0	0	0	1	0	0	0	0	0	0	0	0	0	0	0	0	0	0	0	0	0	0	0	0	0	
	:	:	:	:	:	:	:	:	:	:	:	:	:	:	:	:	:	:	:	:	:	:	:	:	:	:	:	:	:	:	:	
	:	:	:	:	:	:	:	:	:	:	:	:	:	:	:	:	:	:	:	:	:	:	:	:	:	:	:	:	:	:	:	:
	Red(1022)	1	1	1	1	1	1	1	1	1	0	0	0	0	0	0	0	0	0	0	0	0	0	0	0	0	0	0	0	0	0	0
Red(1023)	1	1	1	1	1	1	1	1	1	0	0	0	0	0	0	0	0	0	0	0	0	0	0	0	0	0	0	0	0	0	0	
GrayScale of Green	Green(000)	0	0	0	0	0	0	0	0	0	0	0	0	0	0	0	0	0	0	0	0	0	0	0	0	0	0	0	0	0	0	
	Green(001)	0	0	0	0	0	0	0	0	0	0	0	0	0	0	0	0	0	0	1	0	0	0	0	0	0	0	0	0	0	0	
	:	:	:	:	:	:	:	:	:	:	:	:	:	:	:	:	:	:	:	:	:	:	:	:	:	:	:	:	:	:	:	
	:	:	:	:	:	:	:	:	:	:	:	:	:	:	:	:	:	:	:	:	:	:	:	:	:	:	:	:	:	:	:	:
	Green(1022)	0	0	0	0	0	0	0	0	0	1	1	1	1	1	1	1	1	1	0	0	0	0	0	0	0	0	0	0	0	0	
Green(1023)	0	0	0	0	0	0	0	0	0	1	1	1	1	1	1	1	1	1	1	0	0	0	0	0	0	0	0	0	0	0	0	
GrayScale of Blue	Blue(000)	0	0	0	0	0	0	0	0	0	0	0	0	0	0	0	0	0	0	0	0	0	0	0	0	0	0	0	0	0	0	
	Blue(001)	0	0	0	0	0	0	0	0	0	0	0	0	0	0	0	0	0	0	0	0	0	0	0	0	0	0	0	0	0	1	
	:	:	:	:	:	:	:	:	:	:	:	:	:	:	:	:	:	:	:	:	:	:	:	:	:	:	:	:	:	:	:	
	:	:	:	:	:	:	:	:	:	:	:	:	:	:	:	:	:	:	:	:	:	:	:	:	:	:	:	:	:	:	:	:
	Blue(1022)	0	0	0	0	0	0	0	0	0	0	0	0	0	0	0	0	0	0	0	1	1	1	1	1	1	1	1	1	1	0	
Blue(1023)	0	0	0	0	0	0	0	0	0	0	0	0	0	0	0	0	0	0	0	1	1	1	1	1	1	1	1	1	1	1		

Attention:

0: Low level voltage; 1: High level voltage.

5. V-by-One Each Lane Timing Spec

5.1 Timing Table (DE Only Mode)

2D Mode, Frame Rate=60Hz

Signal	Item	Symbol	Min.	Typ.	Max.	Unit	Note
Frequency		F_{CLK} (= $1 / T_{CLK}$)	71.75	74.25	76.75	MHz	(1)
Frame Rate		F	58	60	62	Hz	
Vertical Term	Total	T_V	2200	2250	2350	T_H	$T_V = T_{VD} + T_{VB}$
	Display	T_{VD}	2160				
	Blank	T_{VB}	40	90	190	T_H	
Horizontal Term	Total	T_H	540	550	600	T_{CLK}	$T_H = T_{HD} + T_{HB}$
	Display	T_{HD}	480				
	Blank	T_{HB}	60	70	120	T_{CLK}	

2D Mode, Frame Rate=50Hz

Signal	Item	Symbol	Min.	Typ.	Max.	Unit	Note
Frequency		F_{CLK} (= $1 / T_{CLK}$)	71.75	74.25	76.75	MHz	(1)
Frame Rate		F	48	50	52	Hz	
Vertical Term	Total	T_V	2200	2700	2760	T_H	$T_V = T_{VD} + T_{VB}$
	Display	T_{VD}	2160			T_H	
	Blank	T_{VB}	40	540	600	T_H	
Horizontal Term	Total	T_H	540	550	600	T_{CLK}	$T_H = T_{HD} + T_{HB}$
	Display	T_{HD}	480			T_{CLK}	
	Blank	T_{HB}	60	70	120	T_{CLK}	

Attention:

The module is operated in DE only mode, Hsync and Vsync input signal have no effect on normal operation.

Note:

(1) Please make sure the range of pixel clock follows the following equations:

$$F_{clk}(max) \geq F_{max} \times T_v \times T_h$$

$$F_{min} \times T_v \times T_h \geq F_{clk}(min)$$

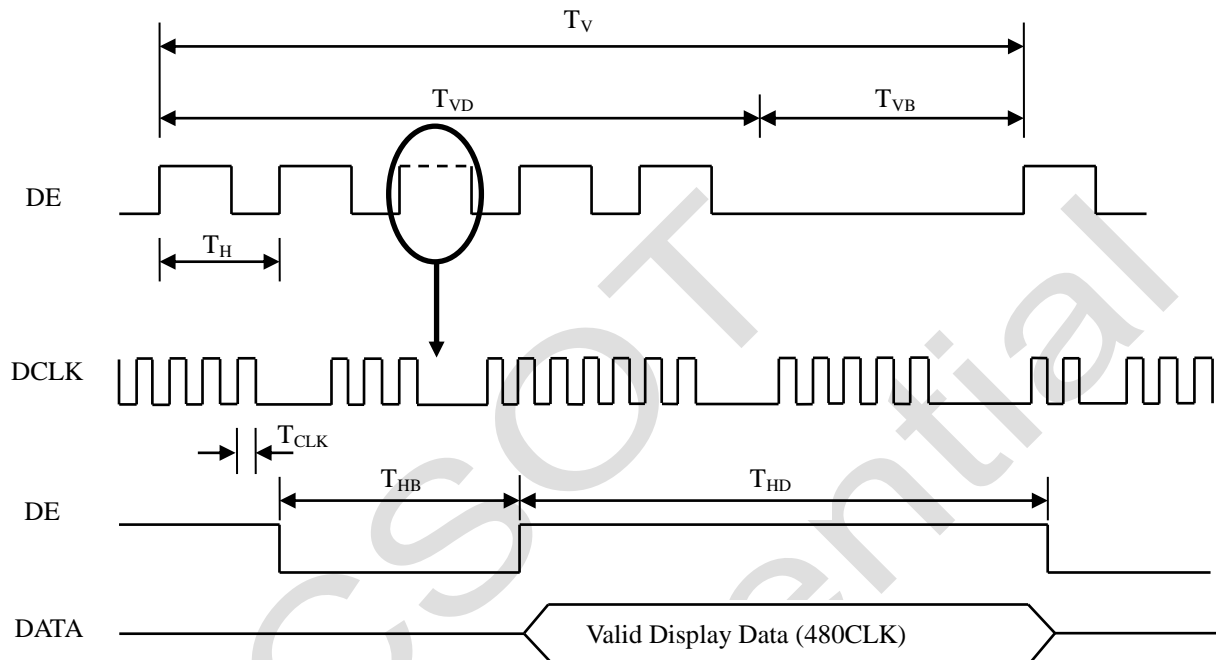

Fig. 5.1 Interface signal timing diagram

5.2 Power On/Off Sequence

5.2.1 Power On/Off Sequence diagram

To prevent a latch-up or DC operation of LCD module, the power on/off change signal sequence should be as the diagram below.

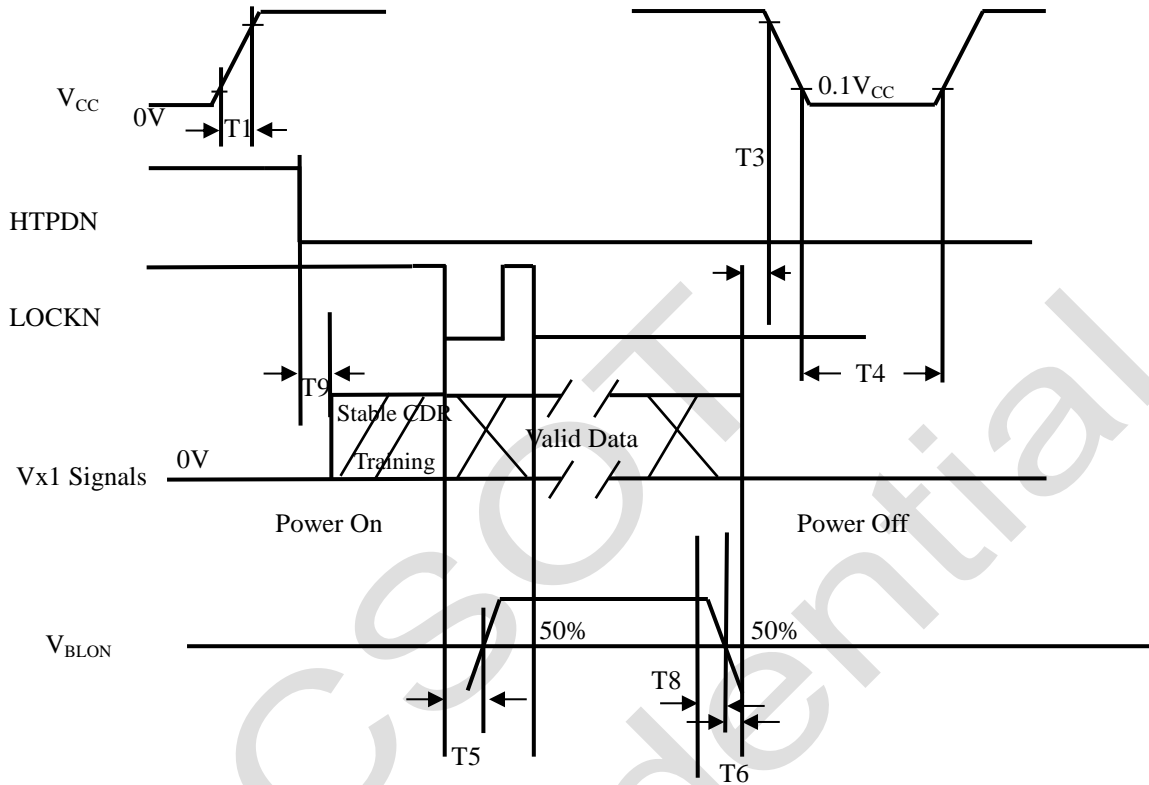
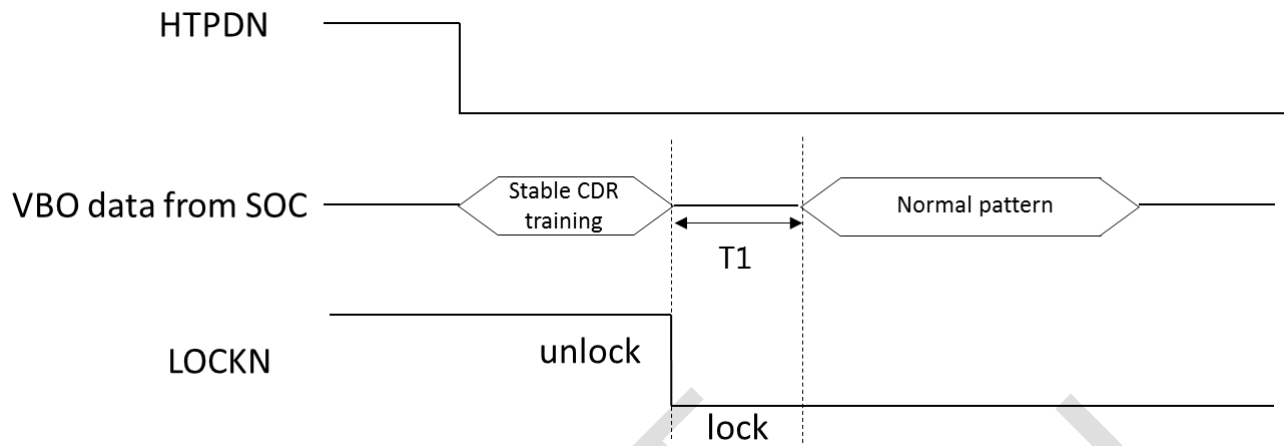

Fig. 5.2 Power on/off change signal sequence

Parameter	Values			Unit
	Min.	Typ.	Max.	
T1	0.5	-	10.0	ms
T3	0	-	-	ms
T4	1000	-	-	ms
T5	500	-	-	ms
T6	100	-	-	ms
T8	10	-	1000	ms
T9	0	-	-	ms

5.2.2 CDR training



Item	Definition	Min.	Typ.	Max.	Unit
T1	Time from LOCKN low to the transmitter of normal pattern	-	-	300	us

Attention:

- (1) Apply the light bar voltage within the LCD operation range. When the backlight turns on before the LCD operation or the LCD turns off before the backlight turns off, the display may momentarily become abnormal screen.
- (2) In case that V_{CC} is in off level, please keep the level of input signals on the low or high impedance. If $T2 < 0$, that may cause electrical overstress.
- (3) $T4$ should be measured after the module has been fully discharged between power off and on period.
- (4) Interface signal shall not be kept at high impedance when the power is on.
- (5) The product should be always operated within above ranges.
- (7) During the first 2s after $T5$, the T-con's output is black pattern.

6. Optical Characteristics

6.1 Measurement Conditions

The table below is the test condition of optical measurement.

Item	Symbol	Value	Unit
Ambient Temperature	T_A	25 ± 2	$^{\circ}\text{C}$
Ambient Humidity	H_A	50 ± 10	%RH
Supply Voltage	V_{CC}	5V	V
Driving Signal	Refer to the typical value in Chapter 3: Electrical Specification		
Vertical Refresh Rate	F_R	60	Hz

To avoid abrupt temperature change during optical measurement, it's suggested to warm up the LCD module more than 60 minutes after lighting the backlight and in the windless environment.

To measure the LCD module, it is suggested to set up the standard measurement system as Fig. 7.1. The measuring area S should contain at least 500 pixels of the LCD module as illustrated in Fig.7.2(A means the area allocated to one pixel).In this model, for example, the minimum measuring distance Z is 370mm when θ is 2 degree. Hence, 500mm is the typical measuring distance. This measuring condition is referred to 301-2H of VESA FPDM 2.0 about viewing distance, angle, and angular field of view definition.

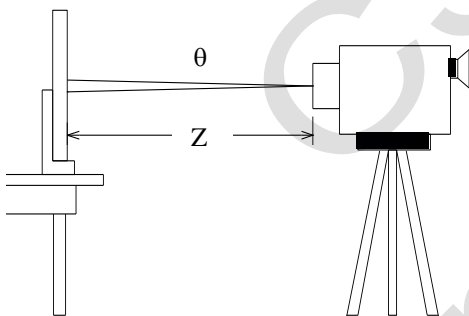

Fig. 6.1 The standard set-up system of measurement

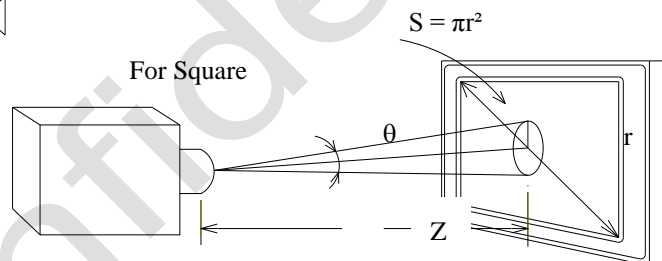

Fig. 6.2 The area S contains at least 500 pixels to be measured

$$N = \frac{S}{A} \geq 500 \text{ pixels}$$

N means the actual number of the pixels in the area S .

6.2 Optical Specifications

The table below of optical characteristics is measured by MINOLTA CS2000,MINOLTA CA310,ELDIM OPTIScope-SAand ELDIM EZContrast in dark room.

Item		Symbol	Condition	Min.	Typ.	Max.	Unit	Note	
Static Contrast Ratio		CR	$\theta_H=0^\circ, \theta_V=0^\circ$ Normal direction at center point CSOT's module: MT5461D01-3	-	4500	-	-	(1)(2)	
Response Time		T_L		-	6.5	12	ms	(3)OPTIScope -SA	
Center Transmittance		T%		-	5.4%			(2) (4)	
Crosstalk		CT-2D		-	-	4%	-	(2) (5)	
Color Chromaticity (CIE1931)	Red	R_X		Typ. -0.03	0.633	Typ. +0.03	-	-	(2) (7)
		R_Y	0.335						
	Green	G_X	0.300						
		G_Y	0.628						
	Blue	B_X	0.153						
		B_Y	0.065						
	White	W_X	0.275						
		W_Y	0.303						
Color Gamut		CG	-	72	-	% NTSC	(2) (7)		
Viewing Angle	Horizontal	θ_{H+}	-	89	-	Deg.	(8)		
		θ_{H-}	-	89	-				
	Vertical	θ_{V+}	-	89	-				
		θ_{V-}	-	89	-				

Note:

(1)Definition of static contrast ratio (CR):

It's necessary to switch off all the dynamic and dimming function when measuring the static contrast ratio.

$$\text{Static Contrast Ratio (CR)} = \frac{\text{CR-W}}{\text{CR-D}}$$

CR-W is the luminance measured by LMD (light-measuring device)at the center point of the LCD module with full-screen displaying white. The standard setup of measurement is illustrated in Fig. 6.3; CR-D is the luminance measured by LMD at the center point of the LCD module with full-screen displaying black.

(2) The LMD in the item could be a spectroradiometer such as (KONICA MINOLTA) CS2000, CS1000,(TOPCON) SR-UL2 or the same level spectroradiometer. Other display color analyzer (KONICA MINOLTA) CA210, CA310 or (TOPCON) BM-7 could be involved after being calibrated with a spectroradiometer on each stage of a product.

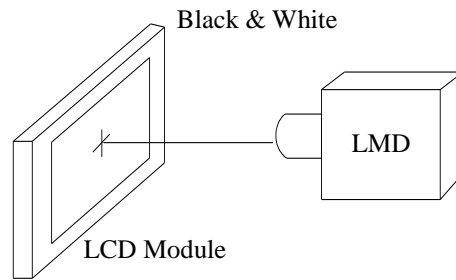

Fig. 6.3 The standard setup of CR measurement

(3) Response time T_L is defined as the average transition time in the response time matrix. The table below is the response time matrix in which each element $t_{X \text{ to } Y}$ is the transition time from luminance ratio X to Y. X and Y are two different luminance ratios among 0%, 25%, 50%, 75%, and 100% luminance. The transition time $t_{X \text{ to } Y}$ is defined as the time taken from 10% to 90% of the luminance difference between X and Y ($X < Y$) as illustrated in Fig 6.4. When $X > Y$, the definition of $t_{X \text{ to } Y}$ is the time taken from 90% to 10% of the luminance difference between X and Y. The response time is optimized on refresh rate $F_R = 60\text{Hz}$.

Measured Transition Time		Luminance Ratio of Previous Frame				
		0%	25%	50%	75%	100%
Luminance Ratio of Current Frame	0%		$t_{25\% \text{ to } 0\%}$	$t_{50\% \text{ to } 0\%}$	$t_{75\% \text{ to } 0\%}$	$t_{100\% \text{ to } 0\%}$
	25%	$t_{0\% \text{ to } 25\%}$		$t_{50\% \text{ to } 25\%}$	$t_{75\% \text{ to } 25\%}$	$t_{100\% \text{ to } 25\%}$
	50%	$t_{0\% \text{ to } 50\%}$	$t_{25\% \text{ to } 50\%}$		$t_{75\% \text{ to } 50\%}$	$t_{100\% \text{ to } 50\%}$
	75%	$t_{0\% \text{ to } 75\%}$	$t_{25\% \text{ to } 75\%}$	$t_{50\% \text{ to } 75\%}$		$t_{100\% \text{ to } 75\%}$
	100%	$t_{0\% \text{ to } 100\%}$	$t_{25\% \text{ to } 100\%}$	$t_{50\% \text{ to } 100\%}$	$t_{75\% \text{ to } 100\%}$	

$t_{X \text{ to } Y}$ means the transition time from luminance ratio X to Y.

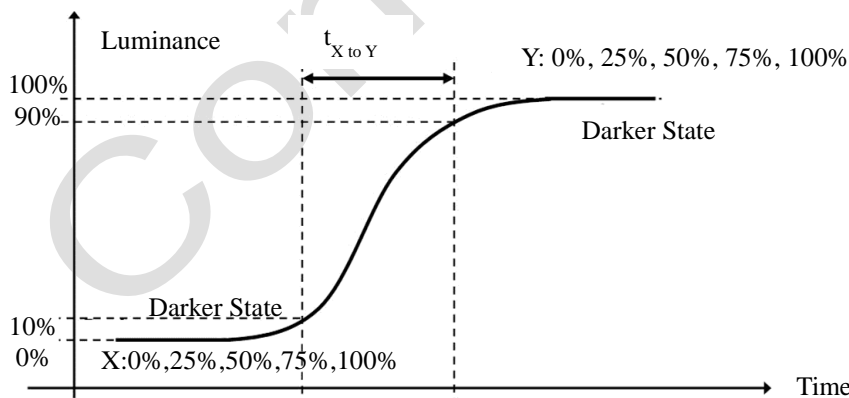

Fig. 6.4 The definition of $t_{X \text{ to } Y}$

All the transition time is measured at the center point of the LCD module by ELDIM OPTI Scope-SA.

(4) Definition of center Transmittance (T %):

The transmittance is measured with full white pattern (Gray 255)

$$\text{Static Contrast Ratio (CR)} = \frac{\text{Luminance of LCD module}}{\text{Luminance of backlight}}$$

(5) Definition of the 2D mode crosstalk (CT-2D):

$$\text{CT-2D} = \frac{|Y_B - Y_A|}{Y_A} \times 100 (\%)$$

YA = Luminance of measured location without gray level 1023 pattern (cd/m²)

YB = Luminance of measured location with gray level 1023 pattern (cd/m²)

Active Area Active Area

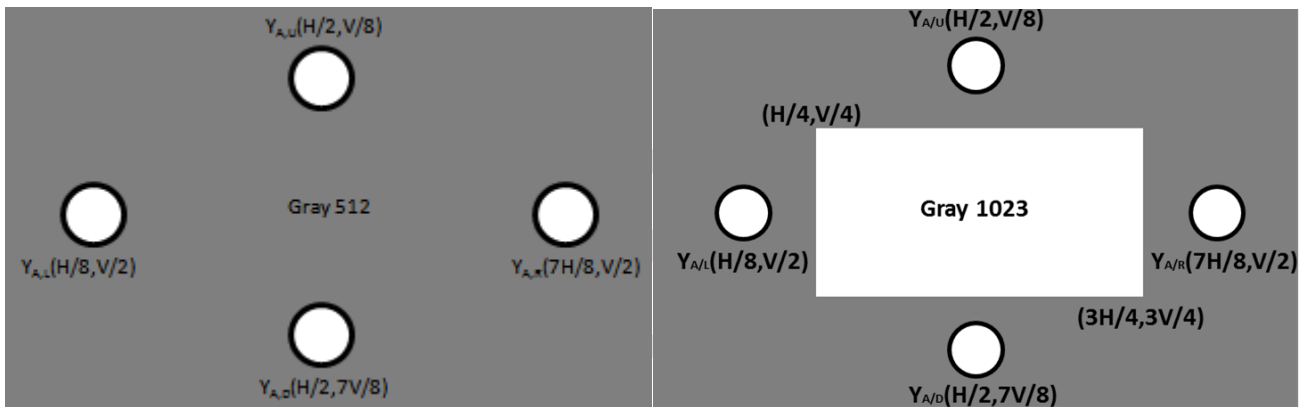

Fig. 6.5 The definition of 2D mode crosstalk

(6) Definition of the 3D mode performance:

Test pattern

Pattern	Left eye image	Right eye image	remark
WW			Left eye image: L255 Right eye image: L255 L(WW) is denoted as the luminance of "WW"
WB			Left eye image: L255 Right eye image: L0 L(WB) is denoted as the luminance of "WB"
BW			Left eye image: L0 Right eye image: L255 L(BW) is denoted as the luminance of "BW"
BB			Left eye image: L0 Right eye image: L0 L(BB) is denoted as the luminance of "BB"

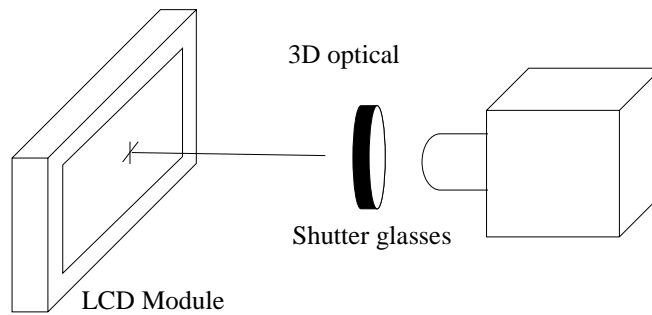

Fig. 6.6 3D optical measurement system

Measure the center point of the LCD module through the shutter glasses under 3D mode operation.

The 3D luminance (L_w -3D) is the luminance measured by LMD with well controlled shutter glasses at the center point of the LCD module with test pattern L(WW).

The 3D crosstalk is measured at the center point of the LCD module through right-eye glasses..

Definition of the 3D mode crosstalk: $CT\text{-}3D = \frac{L(WB) - L(BB)}{L(BW) - L(BB)}$

(7) Definition of color chromaticity:

Each chromaticity coordinates (x, y) are measured in CIE1931 color space when full-screen displaying primary color R, G, B and white. The color gamut is defined as the fraction in percent of the area of the triangle bounded by R, G, B coordinates and the area is defined by NTSC 1953 color standard in the CIE color space. Chromaticity coordinates are measured by CS2000 and the standard setup of measurement is shown in Fig. 6.7.

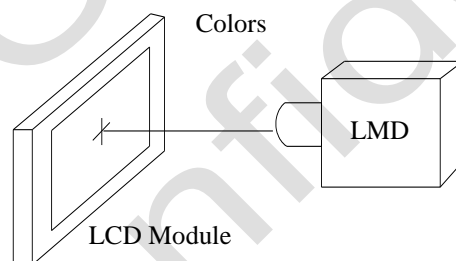

Fig. 6.7 The standard setup of color chromaticity measurement

(8) Definition of viewing angle coordinate system (θ_H, θ_V):

The contrast ratio is measured at the center point of the LCD module. The viewing angles are defined at the angle that the contrast ratio is larger than 10 at four directions relative to the perpendicular direction of the LCD module (two vertical angles: up θ_{V+} and down θ_{V-} ; and two horizontal angles: right θ_{H+} and left θ_{H-}) as illustrated in Fig. 6.8. The contrast ratio is measured by ELDIM EZ Contrast.

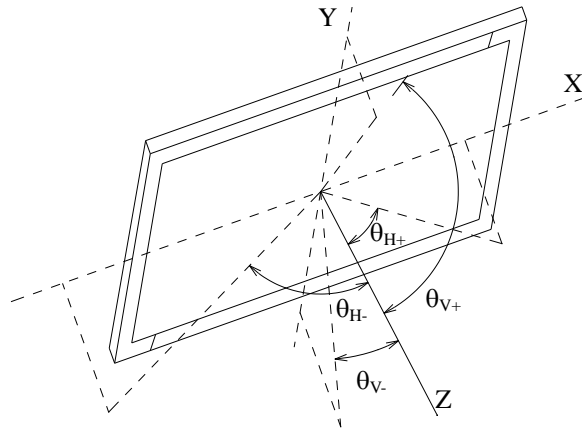
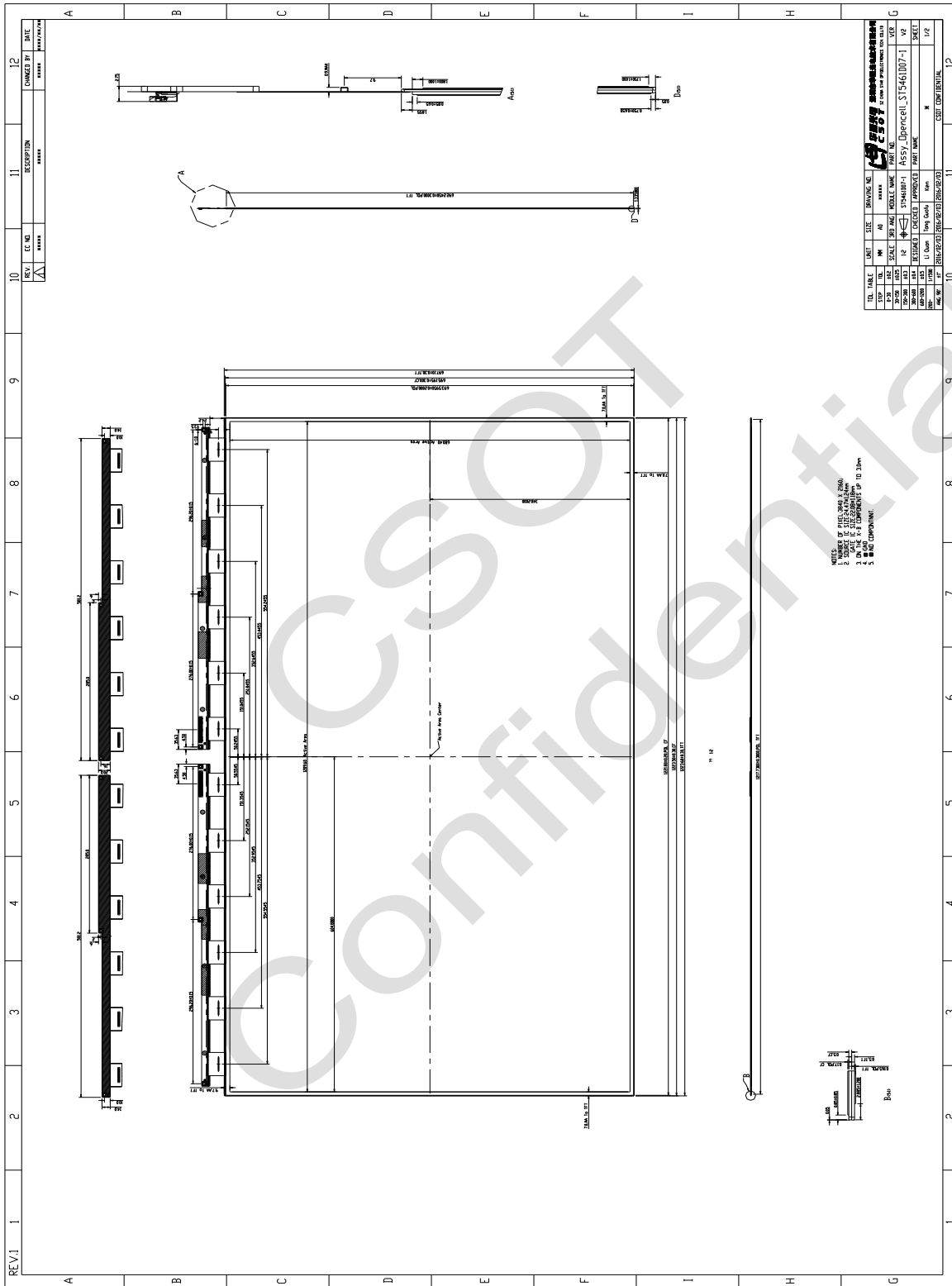

Fig. 6.8 Viewing angle coordination system

CSOT
Confidential

7. Mechanical Characteristics

7.1 Mechanical Specification



7.2 Packing

7.2.1 Packing Specifications

Item	Specification		
	Quantity	Dimension (mm)	Weight (kg)
Packing Box	16pcs/box	1364.00(L) x 1064.00(W) x154.00 (H)	Net Weight: 42.4 (Max.) Gross Weight: 46.9 (Max.)
Pallet	1	1420.00 (L) x 1120.00 (W) x 144.00 (H)	Net Weight:22
Stack Layer	7		
Boxes per Pallet	7		
Pallet after Packing	112pcs/pallet	1420.00 (L) x 1120.00 (W) x 1012.00(H)	Gross Weight:352

7.2.2 Packing Method

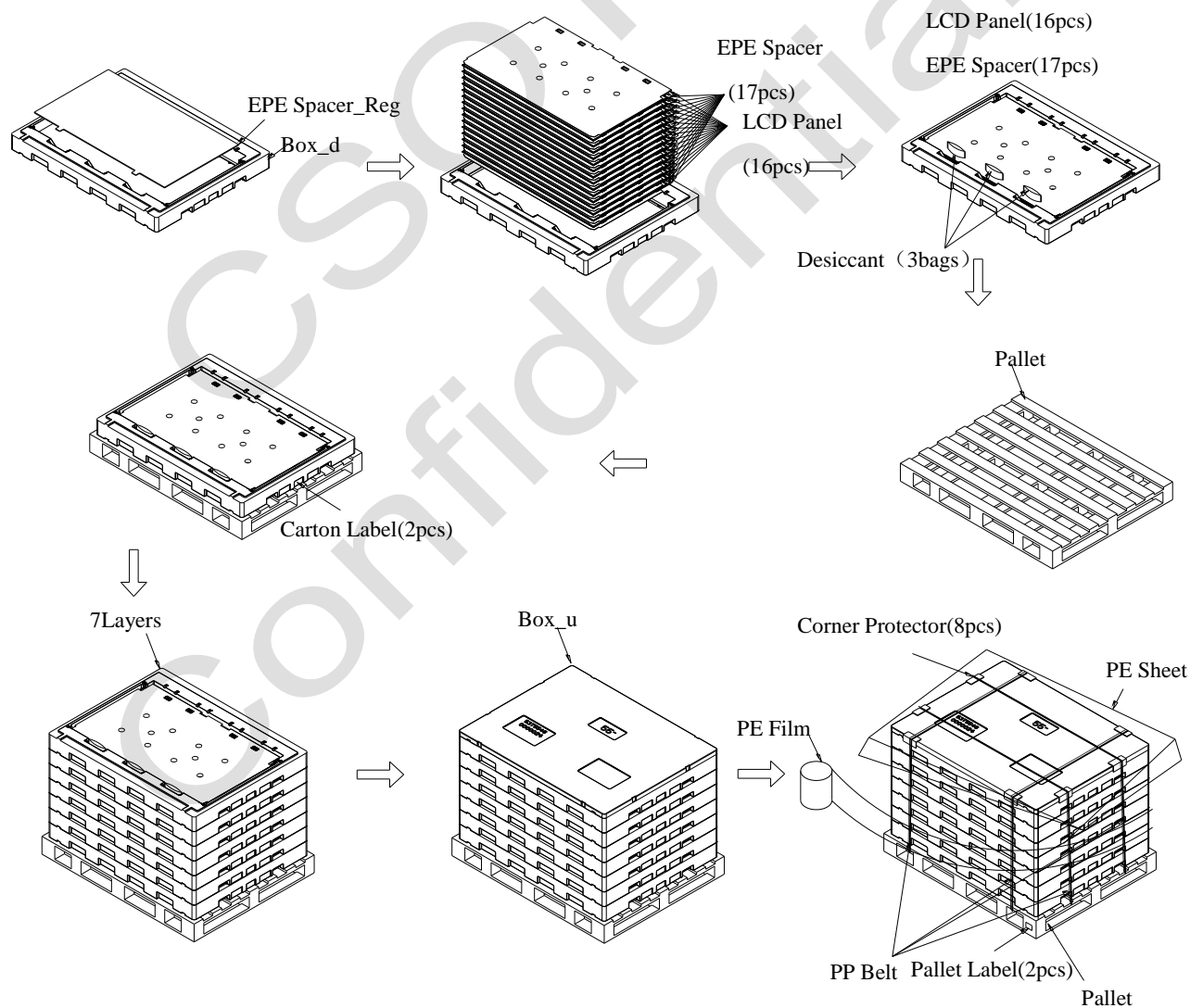

8. Definition of Labels

8.1 Open Cell Label



XXXXXXXXXXXXXXXXXXXXXXXXXXXXST5461D07-1Ver. X.X

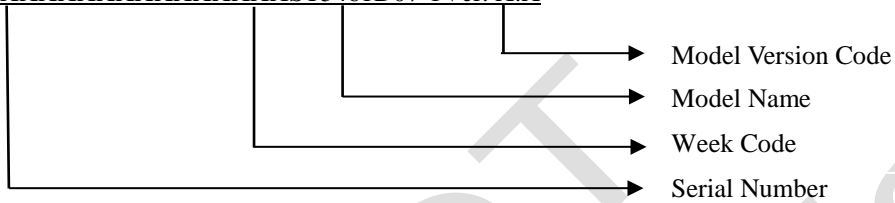

Serial Number: XXXXXXXXXXXXXXXXXXXXXXXX



Week Code: XXXX

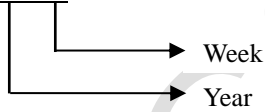

Year: 2010 =10, 2011 = 11 ...2020= 20, 2021= 21...

Week: 01, 02, 03 ...

Model Name: ST5461D07-1

Ver.X.X: Version, for example: 0.1, 0.2, ... , 1.1, 1.2, ..., 2.1, 2.2, ...

8.2 Carton Label

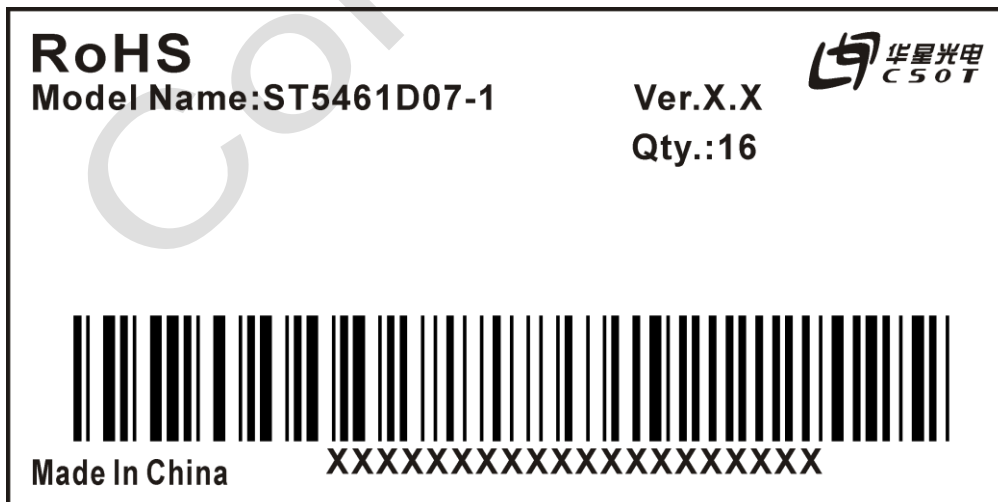

For RoHS compliant products, CSOT will add RoHS for identification.

Serial Number: XXXXXXXXXXXXXXXXXXXXXX

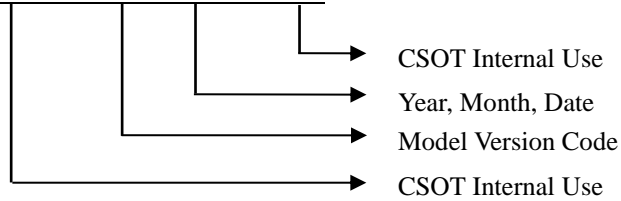

Manufactured Date:

Year: 2010 =10, 2011 = 11...2020= 20, 2021= 21...

Month: 1~9, A~C, for Jan. ~ Dec.

Date: 01~31, for 1st to 31st

Model Version Code: Version of product, for example: 01, 02, 11, 12...

8.3 Pallet Label



Model Name: ST5461D07-1

Serial Number: XXXXXXXXXXXXXXXXXXXXXX

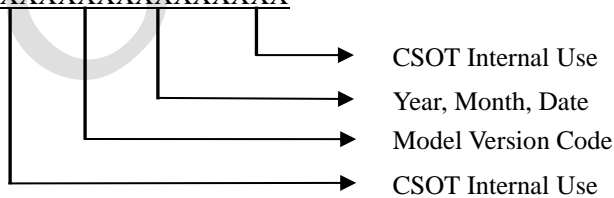

9. Precautions

9.1 Assembly and Handling Precautions

- (1) The device listed in the product specification sheets was designed and manufactured for TV application only.
- (2) Do not apply rough force such as bending or twisting to the open cell during assembly.
- (3) It is recommended to assemble or install a open cell into the user's system in clean working areas. The dust and oil may cause electrical shorter damage the polarizer.
- (4) Do not apply pressure or impulse to the open cell to prevent the damage to the open cell.
- (5) Always follow the correct power-on sequence. This can prevent the damage and latch-up to the LSI chips.
- (6) Do not plug in or pull out the interface connector while the open cell is in operation.
- (7) Use soft dry cloth without chemicals for cleaning because the surface of polarizer is very soft and easily be scratched.
- (8) Moisture can easily penetrate into the open cell and may cause the damage during operation.
- (9) High temperature or humidity may deteriorate the performance of the open cell. Please store open cell in the specified storage conditions.
- (10) When ambient temperature is lower than 10 °C, the display quality might be deteriorated. For example, the response time will become slow.

9.2 Safety Precautions

- (1) If the liquid crystal material leaks from the panel, it should be kept away from the eyes or mouth. In case of contact with hands, skin or clothes, it has to be washed away thoroughly with soap.
- (2) After the open cell end of life, it is not harmful in case of normal operation and storage.