

### 1. INTRODUCTION

ST7026 is a LCD driver & controller LSI for graphic dot-matrix liquid crystal display systems. It contains 48 segment and 4 common driver circuits. ST7026 can be connected directly to a microprocessor with 3-Line serial peripheral interface (3-SPI) or I<sup>2</sup>C compatible interface. Display data written by MPU is stored in an on-chip Display Data RAM (DDRAM) of 48 x 4 bits. ST7026 performs Display Data RAM write-operation without external clock to minimize power consumption. In addition, the built-in LED backlight control circuit can setup an LED backlight system with minimal components if necessary.

### 2. FEATURES

#### Single-chip LCD Controller & Driver

##### Driving Waveform

- A-Type & B-Type

##### Driver Output Circuits

- 4 common / 48 segment outputs

##### On-chip Display Data RAM

- Capacity: 48x4=864bits

##### Support Master/Slave display area

##### Microprocessor Interface

- 3-Line (9-bits) SPI (serial peripheral interface)
- I<sup>2</sup>C Compatible interface

##### With External /RST (hardware reset) Pin

##### Built-in Oscillator requires no external component

##### Power Operating Voltage Range

- Digital Power (VDD1,VDD3): 3.0V~5.0V (TYP.)
- Analog Power (VDD2): 3.0V~5.0V (TYP.)

##### On-chip Low Power Analog Circuit

- Built-in Voltage Booster generates high voltage (x2~x4) (support external VLCD supply)
- Built-in Voltage Regulator generates LCD Vop (support external Vop supply)
- Built-in Voltage Follower generates LCD Bias voltages

##### LCD Driving Voltage Range

- Vop (V0-VSS2): 4V to 18V (Programmable)

##### Fast LCD Display Frame Frequency



- Maximum LCD frame frequency: 320Hz

##### Built-in LED Backlight Control Circuit

- PWM signal is synchronized with LCD frame
- Programmable PWM Frequency: 50~14.4K (Hz)

##### Operation Temperature: -30 ~85°C

##### Package Type: COG

<b>ST7026</b>	<b>3-Line Serial Interface</b>	
	<b>I<sup>2</sup>C Compatible Interface</b>	

Sitronix Technology Corp. reserves the right to change the contents in this document without prior notice.

## 3. PACKAGE INFORMATION

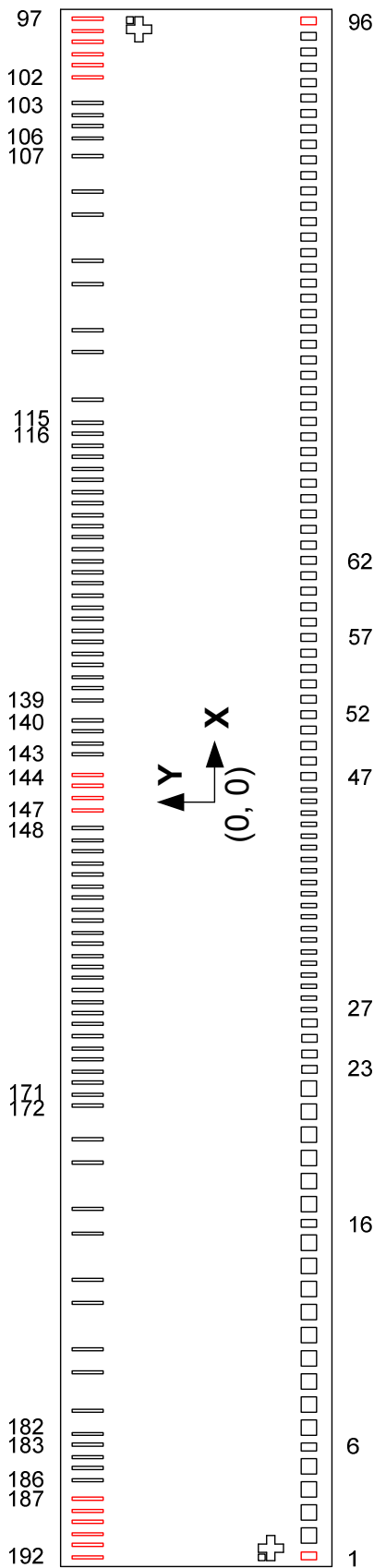

<b>Chip Size</b>	5380 x 904 um (with seal ring and scribe line)		
<b>Chip Thickness</b>	480 um	<b>Bump Height</b>	12um
<b>PAD</b>			<b>Pitch (min)</b>
2~5, 7~15, 17~22			80
1, 6, 16, 23~26, 47~96			50
27~46			40
97~101, 103~105, 115~138, 140~142, 144~146, 148~171, 182~185, 187~191			38
102, 106, 139, 186			68
108, 110, 112, 114, 173, 175, 177, 179, 181			76
143, 147			98
107, 172, 180			114
109, 111, 113, 174, 176, 178			152
<b>PAD</b>			<b>Size</b>
2~5, 7~15, 17~22			63 x 65
1, 6, 16, 23~26, 47~96			33 x 65
27~46			23 x 65
97~192			21 x 96

Note:

Please refer to the coordinates for the detailed information.

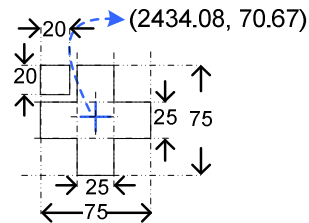

Unit: um

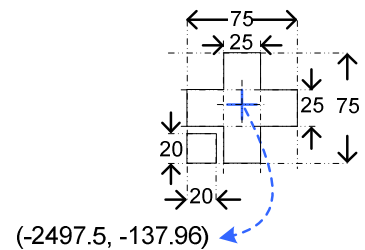
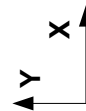

## 4. PIN FUNCTION

PAD NO.	PIN Name	X	Y
1	DUMMY	-2567	-329
2	SYNC	-2502	-329
3	DON	-2422	-329
4	CL	-2342	-329
5	LEDPWM	-2262	-329
6	VSS1	-2197	-329
7	TYPMD	-2132	-329
8	IF	-2052	-329
9	I2CMS0	-1972	-329
10	I2CMS1	-1892	-329
11	PRT0	-1812	-329
12	PRT1	-1732	-329
13	DUTYTS	-1652	-329
14	CLS	-1572	-329
15	M/S	-1492	-329
16	VDD1	-1427	-329
17	/RST	-1362	-329
18	/CS	-1282	-329
19	TCAP	-1202	-329
20	SCK	-1122	-329
21	SDA	-1042	-329
22	SDA	-962	-329
23	VD1	-897	-329
24	VD1	-847	-329
25	VD1OUT	-797	-329
26	VD1OUT	-747	-329
27	T18	-702	-329
28	T17	-662	-329
29	T16	-622	-329
30	T15	-582	-329
31	T14	-542	-329
32	TCOM0	-502	-329
33	T13	-462	-329
34	T12	-422	-329
35	T11	-382	-329
36	T10	-342	-329
37	T9	-302	-329
38	T8	-262	-329
39	T7	-222	-329
40	T6	-182	-329
41	TCOM1	-142	-329
42	T5	-102	-329

PAD NO.	PIN Name	X	Y
43	T4	-62	-329
44	T3	-22	-329
45	T2	18	-329
46	T1	58	-329
47	VDD2	103	-329
48	VDD2	153	-329
49	VDD2	203	-329
50	VDD2	253	-329
51	VDD1	303	-329
52	VDD1	353	-329
53	VDD1	403	-329
54	VDD1	453	-329
55	VDD3	503	-329
56	VDD3	553	-329
57	VSS3	603	-329
58	VSS3	653	-329
59	VSS1	703	-329
60	VSS1	753	-329
61	VSS1	803	-329
62	VSS1	853	-329
63	VSS2	903	-329
64	VSS2	953	-329
65	VSS2	1003	-329
66	VSS2	1053	-329
67	VREF	1103	-329
68	V1	1153	-329
69	V1	1203	-329
70	V2	1253	-329
71	V2	1303	-329
72	V3	1353	-329
73	V3	1403	-329
74	V0IN	1453	-329
75	V0IN	1503	-329
76	V0IN	1553	-329
77	V0IN	1603	-329
78	V0OUT	1653	-329
79	V0OUT	1703	-329
80	CAP3P	1753	-329
81	CAP3P	1803	-329
82	CAP1N	1853	-329
83	CAP1N	1903	-329
84	CAP1P	1953	-329

# ST7026

PAD NO.	PIN Name	X	Y
85	CAP1P	2003	-329
86	CAP2P	2053	-329
87	CAP2P	2103	-329
88	CAP2N	2153	-329
89	CAP2N	2203	-329
90	VLCDOUT	2253	-329
91	VLCDOUT	2303	-329
92	VLCDIN	2353	-329
93	VLCDIN	2403	-329
94	VLCDIN	2453	-329
95	VLCDIN	2503	-329
96	DUMMY	2553	-329
97	DUMMY	2567	313
98	DUMMY	2529	313
99	DUMMY	2491	313
100	DUMMY	2453	313
101	DUMMY	2415	313
102	DUMMY	2377	313
103	COM0	2309	313
104	COM1	2271	313
105	COM2	2233	313
106	COM3	2195	313
107	Reserve	2127	313
108	Reserve	2013	313
109	Reserve	1937	313
110	Reserve	1785	313
111	Reserve	1709	313
112	Reserve	1557	313
113	Reserve	1481	313
114	Reserve	1329	313
115	Reserve	1253	313
116	SEG47	1215	313
117	SEG46	1177	313
118	SEG45	1139	313
119	SEG44	1101	313
120	SEG43	1063	313
121	SEG42	1025	313
122	SEG41	987	313
123	SEG40	949	313
124	SEG39	911	313
125	SEG38	873	313
126	SEG37	835	313
127	SEG36	797	313
128	SEG35	759	313
129	SEG34	721	313

PAD NO.	PIN Name	X	Y
130	SEG33	683	313
131	SEG32	645	313
132	SEG31	607	313
133	SEG30	569	313
134	SEG29	531	313
135	SEG28	493	313
136	SEG27	455	313
137	SEG26	417	313
138	SEG25	379	313
139	SEG24	341	313
140	COM3	273	313
141	COM2	235	313
142	COM1	197	313
143	COM0	159	313
144	DUMMY	61	313
145	DUMMY	23	313
146	DUMMY	-15	313
147	DUMMY	-53	313
148	SEG23	-151	313
149	SEG22	-189	313
150	SEG21	-227	313
151	SEG20	-265	313
152	SEG19	-303	313
153	SEG18	-341	313
154	SEG17	-379	313
155	SEG16	-417	313
156	SEG15	-455	313
157	SEG14	-493	313
158	SEG13	-531	313
159	SEG12	-569	313
160	SEG11	-607	313
161	SEG10	-645	313
162	SEG9	-683	313
163	SEG8	-721	313
164	SEG7	-759	313
165	SEG6	-797	313
166	SEG5	-835	313
167	SEG4	-873	313
168	SEG3	-911	313
169	SEG2	-949	313
170	SEG1	-987	313
171	SEG0	-1025	313
172	Reserve	-1063	313
173	Reserve	-1177	313
174	Reserve	-1253	313

## ST7026

---

PAD NO.	PIN Name	X	Y
175	Reserve	-1405	313
176	Reserve	-1481	313
177	Reserve	-1633	313
178	Reserve	-1709	313
179	Reserve	-1861	313
180	Reserve	-1937	313
181	Reserve	-2081	313
182	Reserve	-2157	313
183	COM3	-2195	313
184	COM2	-2233	313
185	COM1	-2271	313
186	COM0	-2309	313
187	DUMMY	-2377	313
188	DUMMY	-2415	313
189	DUMMY	-2453	313
190	DUMMY	-2491	313
191	DUMMY	-2529	313
192	DUMMY	-2567	313

Unit: um

5. BLOCK DIAGRAM

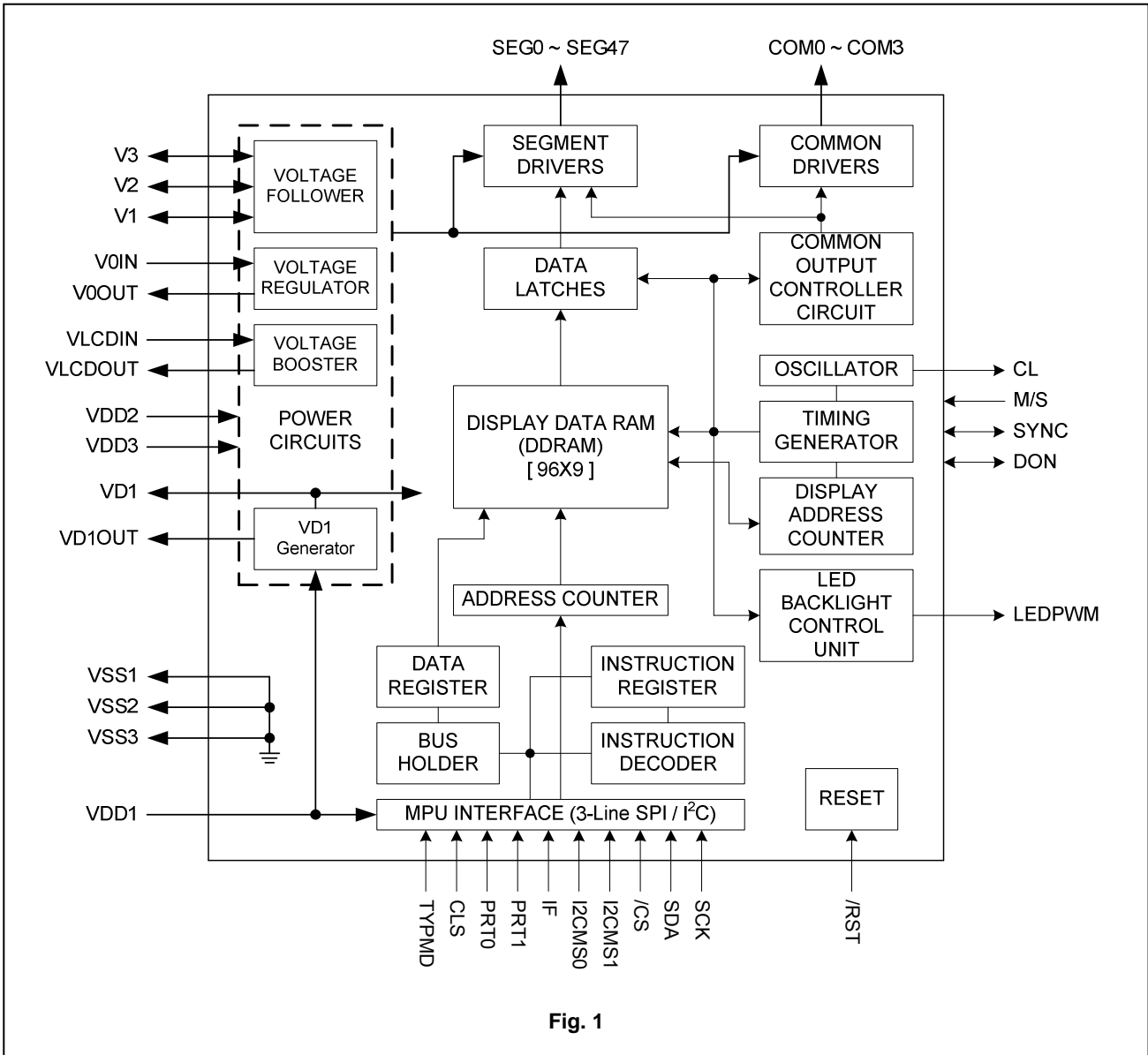

Fig. 1

## 6. PIN DESCRIPTION

### MICROPROCESSOR INTERFACE PINS

Pin Name	Type	Description															
/CS	Input	Chip select input pin. When using 3-Line serial interface, SDA & SCK pins are enabled only when /CS is "H" When use I <sup>2</sup> C interface. /CS pin is unused, please fix to "H".															
/RST	Input	Reset input pin. When /RST is "L", initialization is being executed.															
SDA	I/O	For 3-Line serial interface mode: serial data input and output. For I <sup>2</sup> C compatible interface: this pin is serial data input and ACK signal output. Note: SDA 2 pins should be connected together.															
SCK	Input	Serial clock input.															
IF	Input	Interface type select input: <table border="1"> <thead> <tr> <th>IF</th> <th>MPU Interface Type</th> </tr> </thead> <tbody> <tr> <td>L</td> <td>I<sup>2</sup>C Interface</td> </tr> <tr> <td>H</td> <td>3-Line SPI (9-bit serial)</td> </tr> </tbody> </table>	IF	MPU Interface Type	L	I <sup>2</sup> C Interface	H	3-Line SPI (9-bit serial)									
IF	MPU Interface Type																
L	I <sup>2</sup> C Interface																
H	3-Line SPI (9-bit serial)																
I2CMS0 I2CMS1	Input	Select pin of I <sup>2</sup> C interface slave address: <table border="1"> <thead> <tr> <th>I2CMS1</th> <th>I2CMS0</th> <th>I2C Address</th> </tr> </thead> <tbody> <tr> <td>0</td> <td>0</td> <td>0111000</td> </tr> <tr> <td>0</td> <td>1</td> <td>0111001</td> </tr> <tr> <td>1</td> <td>0</td> <td>0111010</td> </tr> <tr> <td>1</td> <td>1</td> <td>0111011</td> </tr> </tbody> </table>	I2CMS1	I2CMS0	I2C Address	0	0	0111000	0	1	0111001	1	0	0111010	1	1	0111011
I2CMS1	I2CMS0	I2C Address															
0	0	0111000															
0	1	0111001															
1	0	0111010															
1	1	0111011															
TYPMD	Input	Select pin of driving waveform: <table border="1"> <thead> <tr> <th>TYPMD</th> <th>LCD Drive Waveform</th> </tr> </thead> <tbody> <tr> <td>L</td> <td>B-Type</td> </tr> <tr> <td>H</td> <td>A-Type</td> </tr> </tbody> </table>	TYPMD	LCD Drive Waveform	L	B-Type	H	A-Type									
TYPMD	LCD Drive Waveform																
L	B-Type																
H	A-Type																

## LCD DRIVER PINS

Pin Name	I/O	Description																									
SEG0 ~ SEG47	Output	These pins are LCD driver segment outputs. The display data and internal frame signal control the output voltage of segment driver.																									
		<table border="1"> <thead> <tr> <th>Frame</th> <th colspan="2">Positive Frame</th> <th colspan="2">Negative Frame</th> </tr> <tr> <th>Display Data</th> <th>ON</th> <th>OFF</th> <th>ON</th> <th>OFF</th> </tr> </thead> <tbody> <tr> <td>1/4 Bias</td> <td>V0</td> <td>V2</td> <td>VSS</td> <td>V2</td> </tr> <tr> <td>1/3 Bias</td> <td>V0</td> <td>V2</td> <td>VSS</td> <td>V1</td> </tr> <tr> <td>1/2 Bias</td> <td>V0</td> <td>VSS</td> <td>VSS</td> <td>V0</td> </tr> </tbody> </table>	Frame	Positive Frame		Negative Frame		Display Data	ON	OFF	ON	OFF	1/4 Bias	V0	V2	VSS	V2	1/3 Bias	V0	V2	VSS	V1	1/2 Bias	V0	VSS	VSS	V0
		Frame	Positive Frame		Negative Frame																						
		Display Data	ON	OFF	ON	OFF																					
		1/4 Bias	V0	V2	VSS	V2																					
1/3 Bias	V0	V2	VSS	V1																							
1/2 Bias	V0	VSS	VSS	V0																							
COM0 ~ COM3	Output	These pins are LCD driver common outputs. The internal scan data and frame signal control the output voltage of common driver.																									
		<table border="1"> <thead> <tr> <th>Frame</th> <th colspan="2">Positive Frame</th> <th colspan="2">Negative Frame</th> </tr> <tr> <th>Scan Data</th> <th>ON</th> <th>OFF</th> <th>ON</th> <th>OFF</th> </tr> </thead> <tbody> <tr> <td>1/4 Bias</td> <td>VSS</td> <td>V1</td> <td>V0</td> <td>V3</td> </tr> <tr> <td>1/3 Bias</td> <td>VSS</td> <td>V1</td> <td>V0</td> <td>V2</td> </tr> <tr> <td>1/2 Bias</td> <td>VSS</td> <td>V1</td> <td>V0</td> <td>V1</td> </tr> </tbody> </table>	Frame	Positive Frame		Negative Frame		Scan Data	ON	OFF	ON	OFF	1/4 Bias	VSS	V1	V0	V3	1/3 Bias	VSS	V1	V0	V2	1/2 Bias	VSS	V1	V0	V1
		Frame	Positive Frame		Negative Frame																						
		Scan Data	ON	OFF	ON	OFF																					
		1/4 Bias	VSS	V1	V0	V3																					
1/3 Bias	VSS	V1	V0	V2																							
1/2 Bias	VSS	V1	V0	V1																							
PRT1 PRT0	Input	Select pin of display duty option:																									
		<table border="1"> <thead> <tr> <th>PRT1</th> <th>PRT0</th> <th>Duty</th> </tr> </thead> <tbody> <tr> <td>0</td> <td>0</td> <td>1</td> </tr> <tr> <td>0</td> <td>1</td> <td>1/2</td> </tr> <tr> <td>1</td> <td>0</td> <td>1/3</td> </tr> <tr> <td>1</td> <td>1</td> <td>1/4</td> </tr> </tbody> </table>	PRT1	PRT0	Duty	0	0	1	0	1	1/2	1	0	1/3	1	1	1/4										
		PRT1	PRT0	Duty																							
		0	0	1																							
		0	1	1/2																							
1	0	1/3																									
1	1	1/4																									



## LCD POWER SUPPLY PINS

Pin Name	Type	Description																								
VLCDIN VLCDOUT	Power	When using internal Voltage Booster, VLCDIN & VLCDOUT should be connected together and then connect it with a capacitor to VSS2. When using external booster, please apply the external high voltage power to VLCDIN. In this case, VLCDIN & VLCDOUT should be connected together FPC or PCB and then connect it with a capacitor to VSS2.																								
V0IN V0OUT V1 V2 V3	Power	LCD driver supply voltages. V0IN is the V0 supply of LCD drivers. V0OUT is the output voltage of V0 generated by ST7026. When the internal power circuits are turned ON, these voltages are generated and the relations are listed in the following table. Please connect V0IN and V0OUT together by FPC or PCB and then connect it with a capacitor to VSS2. <table border="1" style="margin-left: 20px;"> <thead> <tr> <th>Bias Setting</th> <th>V0</th> <th>V1</th> <th>V2</th> <th>V3</th> <th>VSS</th> </tr> </thead> <tbody> <tr> <td>1/2</td> <td>V0</td> <td>1/2*V0</td> <td>1/2*V0</td> <td>1/2*V0</td> <td>VSS</td> </tr> <tr> <td>1/3</td> <td>V0</td> <td>2/3*V0</td> <td>1/3*V0</td> <td>1/3*V0</td> <td>VSS</td> </tr> <tr> <td>1/4</td> <td>V0</td> <td>3/4*V0</td> <td>2/4*V0</td> <td>1/4*V0</td> <td>VSS</td> </tr> </tbody> </table>	Bias Setting	V0	V1	V2	V3	VSS	1/2	V0	1/2*V0	1/2*V0	1/2*V0	VSS	1/3	V0	2/3*V0	1/3*V0	1/3*V0	VSS	1/4	V0	3/4*V0	2/4*V0	1/4*V0	VSS
Bias Setting	V0	V1	V2	V3	VSS																					
1/2	V0	1/2*V0	1/2*V0	1/2*V0	VSS																					
1/3	V0	2/3*V0	1/3*V0	1/3*V0	VSS																					
1/4	V0	3/4*V0	2/4*V0	1/4*V0	VSS																					
CAP1N	Power	DC/DC voltage converter. Connect a non-polar capacitor between this terminal and the CAP1P, CAP3P terminal.																								
CAP2N	Power	DC/DC voltage converter. Connect a non-polar capacitor between this terminal and the CAP2P terminal.																								
CAP1P	Power	DC/DC voltage converter for LCD circuit. Connect a non-polar capacitor between this terminal and the CAP1N terminal.																								
CAP2P	Power	DC/DC voltage converter. Connect a non-polar capacitor between this terminal and the CAP2N terminal.																								
CAP3P	Power	DC/DC voltage converter for LCD circuit. Connect a non-polar capacitor between this terminal and the CAP1N terminal.																								

Note : Booster is controlled by CAPs, please refer to Page 19.

## POWER SUPPLY PINS

Pin Name	Type	Description
VDD1	Power	Power supply for Interface I/O circuit and OSC circuit. VDD1 and VDD3 are separated in ITO and connected together by FPC or PCB.
VDD2	Power	Power supply for analog power for booster circuit and OP.
VDD3	Power	Power supply for VREF circuit. VDD1 and VDD3 are separated in ITO and connected together by FPC or PCB.
VSS1	Power	Ground of interface, logic and OSC circuit. Ground system should be connected by FPC or PCB.
VSS2	Power	Ground of booster circuit and OP. Ground system should be connected by FPC or PCB.
VSS3	Power	Ground of VREF circuit. Ground system should be connected by FPC or PCB.
VD1 VD1OUT	Power	VD1 & VD1OUT is reserved to monitor internal logical power status only. VD1 and VD1OUT should be connected together by FPC or PCB.

## MASTER/SLAVE CONTROL PINS

Pin Name	Type	Description																									
M/S	Input	Select Master/Slave mode pin.																									
		<table border="1"> <thead> <tr> <th>M/S</th> <th>Mode</th> </tr> </thead> <tbody> <tr> <td>0</td> <td>Slave</td> </tr> <tr> <td>1</td> <td>Master</td> </tr> </tbody> </table>	M/S	Mode	0	Slave	1	Master																			
		M/S	Mode																								
0	Slave																										
1	Master																										
CLS	Input	Select pin of clock external or Internal:																									
		<table border="1"> <thead> <tr> <th>CLS</th> <th>CLOCK</th> </tr> </thead> <tbody> <tr> <td>0</td> <td>External</td> </tr> <tr> <td>1</td> <td>Internal</td> </tr> </tbody> </table>	CLS	CLOCK	0	External	1	Internal																			
		CLS	CLOCK																								
0	External																										
1	Internal																										
CL	I/O	When using Master/Slave mode. All of CL should be connected Please note only when M/S & CLS are both "H", CL can set to Output PWM Clock.																									
		<table border="1"> <thead> <tr> <th>M/S</th> <th>CLS</th> <th>CL</th> <th>DON</th> <th>SYNC</th> </tr> </thead> <tbody> <tr> <td>0</td> <td>0</td> <td>Clock Input</td> <td>Input</td> <td>Input</td> </tr> <tr> <td>0</td> <td>1</td> <td>Clock Input</td> <td>Input</td> <td>Input</td> </tr> <tr> <td>1</td> <td>0</td> <td>Clock Input</td> <td>Output</td> <td>Output</td> </tr> <tr> <td>1</td> <td>1</td> <td>Clock Output</td> <td>Output</td> <td>Output</td> </tr> </tbody> </table>	M/S	CLS	CL	DON	SYNC	0	0	Clock Input	Input	Input	0	1	Clock Input	Input	Input	1	0	Clock Input	Output	Output	1	1	Clock Output	Output	Output
		M/S	CLS	CL	DON	SYNC																					
		0	0	Clock Input	Input	Input																					
		0	1	Clock Input	Input	Input																					
1	0	Clock Input	Output	Output																							
1	1	Clock Output	Output	Output																							
SYNC	I/O	When using Master/Slave mode. All of SYNC should be connected If not this pin should be open.																									
DON	I/O	When using Master/Slave mode. All of DON should be connected If not this pin should be open.																									

## LED BACKLIGHT CONTROL PIN

Pin Name	Type	Description
LEDPWM	Output	LED backlight control pin. Please don't drive LED by this pin directly.

\*Please refer to the "LED Backlight connection" section for the LED backlight control application notes.

## TEST PIN

Pin Name	Type	Description
DUMMY	-	Dummy pins and let them open.
Reserve	-	Reserve pins and let them open.
DUTYTS		Test pin and connect to VSS.
Vref	-	Test pin and let it open.
T1~T18	-	Test pins and let them open.
TCAP	-	Test pin and let it open.
TCOM0 TCOM1	-	Test pins and let them open.

# ST7026

## ITO RESISTANCE (for COG application)

Pin Name	ITO Resistance
DUMMY T1~T18, TCAP, TCOM0, TCOM1, Vref	Floating
VDD1, VDD2, VDD3, VD1, VD1OUT, VLCDIN, VLCDOUT, VSS1, VSS2, VSS3	< 100Ω
CAP1P, CAP1N, CAP2P, CAP2N, CAP3P, V3, V2, V1, V0IN, V0OUT	< 150Ω
/CS, LEDPWM, SDA, SCK	< 1KΩ
SYNC, DON, CL	< 3KΩ
M/S, IF, CLS, I2CMS0, I2CMS1, PRT0, PRT1, TYPMD, /RST *1	< 5KΩ

Note:

1. The Limitations include the bottleneck of ITO layout.
2. Make sure that the ITO resistance of COM0 ~ COM3 is equal, and so is it of SEG0 ~ SEG47.
3. To avoid the noise in different power systems affect other power system, please separate them on ITO layout.
4. The V0, VLCD and VD1 power circuits have output pins and input pins. To avoid the power noise affects the sensor of the power circuits. The trace should be separated by ITO and should be connected together by FPC.

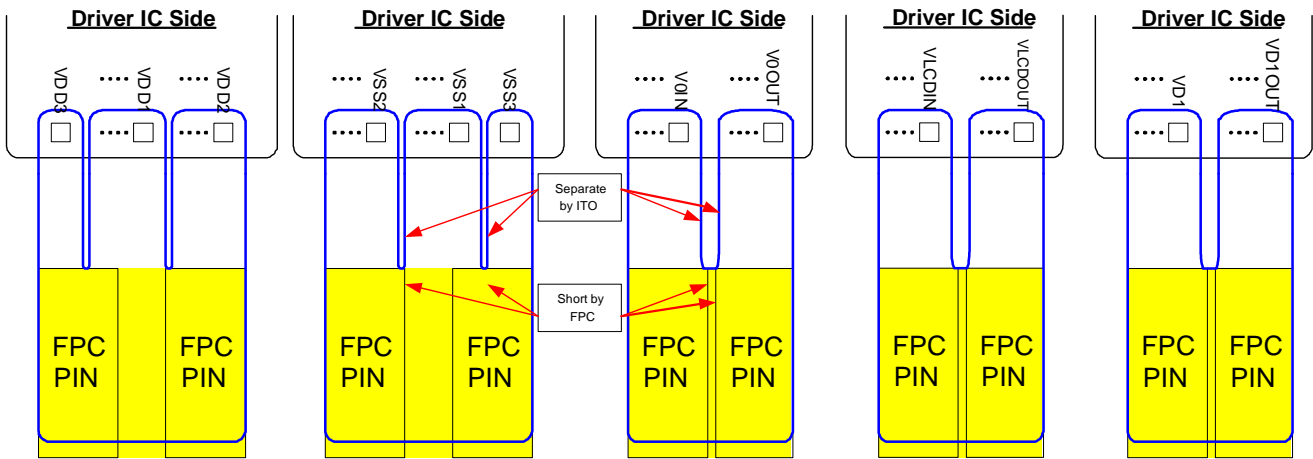

5. If panel layout cannot meet recommended ITO resistance and traces must be connected on ITO to lower the resistance, below layout rule must be followed.

The equivalent circuit is shown below:

VD1 & VD1OUT	VDD	VSS
<p><b>Ideal Layout:</b> =&gt; <math>R3=0\text{ Ohm}</math>. <math>R1&gt;R2</math>.</p> <p><b>Acceptable Layout:</b> =&gt; <math>R3\neq 0</math>. <math>R1\geq R2 &gt;R3</math>.</p> <p><b>Not Acceptable:</b> =&gt; <math>R3 \geq (R1\text{ or }R2)</math></p>	<p><b>Ideal Layout:</b> =&gt; <math>R4=0\text{ Ohm}</math>. <math>R3\gg R1&gt;R2</math>.</p> <p><b>Acceptable Layout:</b> =&gt; <math>R4\neq 0</math>. <math>R3\gg R1&gt;R2&gt;R4</math>.</p> <p><b>Not Acceptable:</b> =&gt; <math>R4\geq (R1\text{ or }R2\text{ or }R3)</math>.</p>	<p><b>Ideal Layout:</b> =&gt; <math>R4=0\text{ Ohm}</math>. <math>R2\gg R1&gt;R3</math>.</p> <p><b>Acceptable Layout:</b> =&gt; <math>R4\neq 0</math>. <math>R2\gg R1&gt;R3&gt;R4</math>.</p> <p><b>Not Acceptable:</b> =&gt; <math>R4\geq (R1\text{ or }R2\text{ or }R3)</math>.</p>

## 7. FUNCTIONS DESCRIPTION

### MICROPROCESSOR INTERFACE

The microprocessor interface of ST7026 can be selected by IF pin to communicate with different type of MPU. Please refer to the table below:

IF Setting	Interface Mode	Available Pins for MPU
H	3-Line SPI (Serial Peripheral Interface)	SDA, SCK, /CS, /RST
L	I <sup>2</sup> C compatible interface	SDA, SCK, /RST

#### 3-Line SPI Interface (9-bit)

The 3-Line SPI (9-bit) uses 3 pins (/CS, SDA & SCK) to communicate with MPU. When /CS is “L”, IC is active and the SDA and SCK pins are enabled. Serial data is latched at the rising edge of serial clock. The internal shift register collects serial bits and reformat them into 8-bit data after the last (9<sup>th</sup>) clock. After /CS returns to “H”, IC is inactive and the internal shift register and counter are reset. The parameter/command indicator is the “A0” bit: the 1<sup>st</sup> bit of each 9-bit serial data.

#### Write Parameter by 3-Line SPI (A0=1)

When A0 is “1”, the transferred 8-bit is parameter.

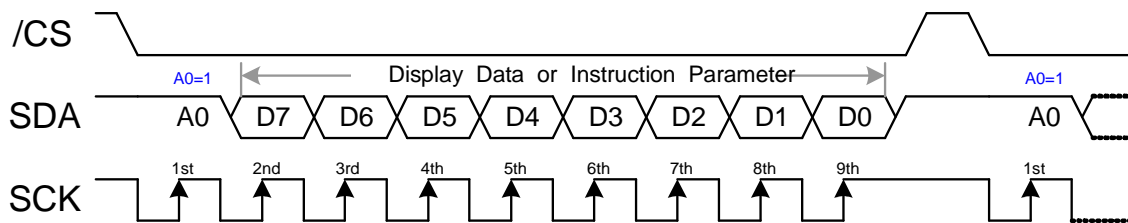

Fig. 2 Write Parameter in 3-Line SPI

#### Write Instruction by 3-Line SPI (A0=0)

When A0 is “0”, the transferred 8-bit is instruction.

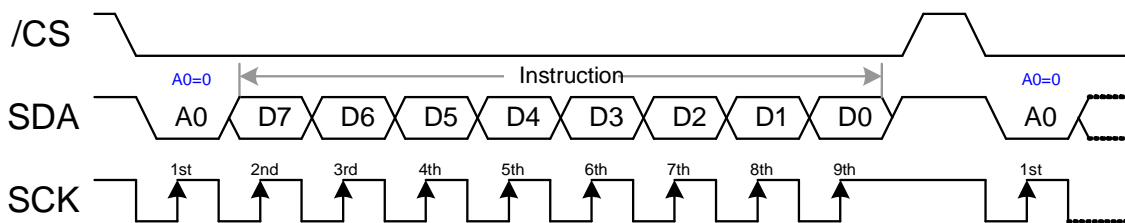

Fig. 3 Write Instruction in 3-Line SPI

## I<sup>2</sup>C Compatible Interface

The I<sup>2</sup>C Compatible Interface is for bi-directional, two-line communication between different ICs or modules. The two lines are a Serial Data line (SDA) and a Serial Clock line (SCL). Both lines must be connected with a pull-up resistor which drives SDA and SCL to high when the bus is not busy. Data transfer can be initiated only when the bus is not busy.

### BIT TRANSFER

One data bit is transferred during each clock pulse. The data on the SDA line must remain stable during the HIGH period of the clock pulse because changes of SDA line at this time will be interpreted as START or STOP. Bit transfer is illustrated in Fig 4.

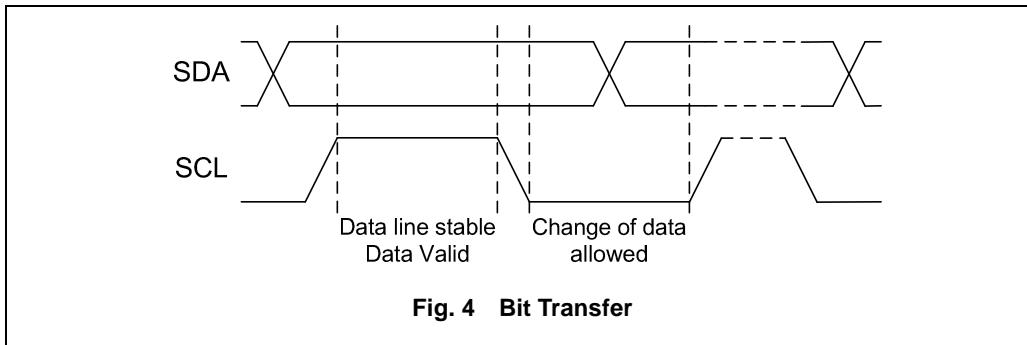

Fig. 4 Bit Transfer

### START AND STOP CONDITIONS

Both SDA and SCL lines remain HIGH when the bus is not busy. A HIGH-to-LOW transition of SDA, while SCL is HIGH is defined as the START condition (S). A LOW-to-HIGH transition of SDA while SCL is HIGH is defined as the STOP condition (P). The START and STOP conditions are illustrated in Fig 5.

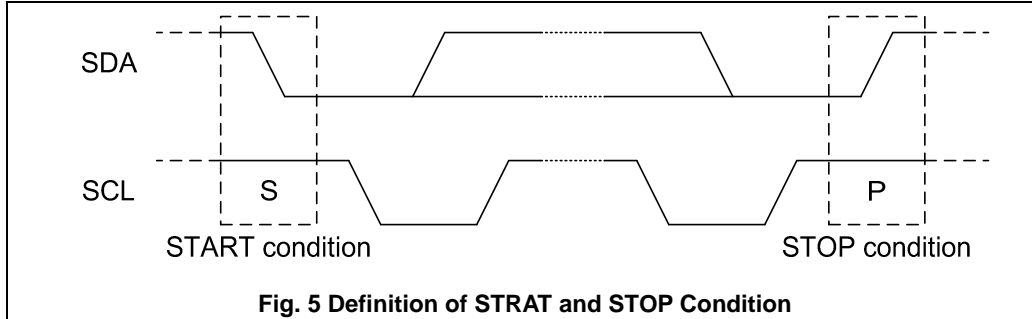

Fig. 5 Definition of STRAT and STOP Condition

### SYSTEM CONFIGURATION

The system configuration is illustrated in Fig 6. and some word-definitions are explained below:

- Transmitter: the device which sends the data to the bus.
- Receiver: the device which receives the data from the bus.
- Master: the device which initiates a transfer, generates clock signals and terminates a transfer.
- Slave: the device which is addressed by a master.

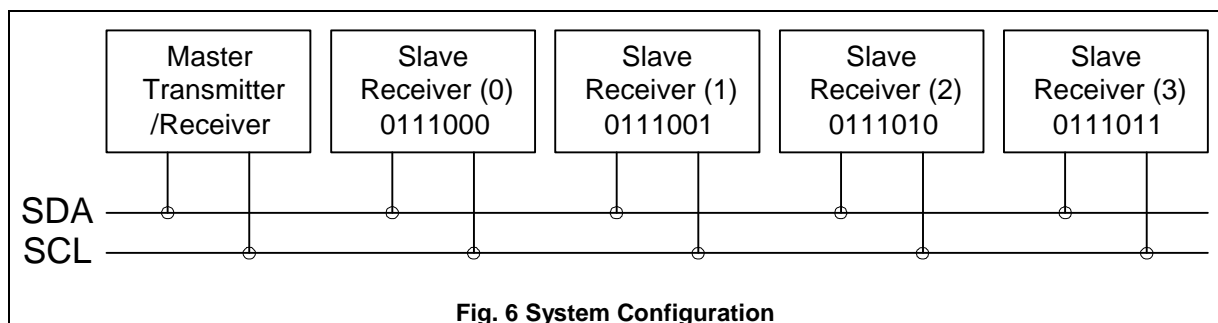
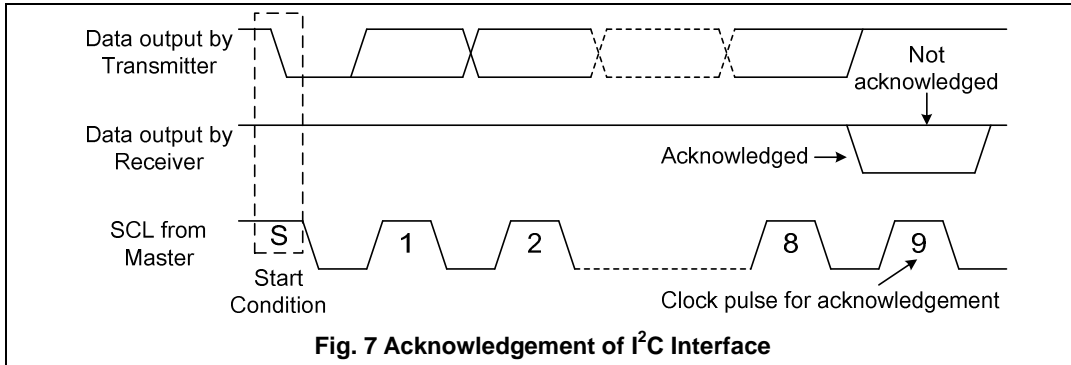

Fig. 6 System Configuration

## ACKNOWLEDGEMENT

Each byte of eight bits is followed by an acknowledge-bit. The acknowledge-bit is a HIGH signal put on SDA by the transmitter during the time when the master generates an extra acknowledge-related clock pulse. A slave receiver which is addressed must generate an acknowledge-bit after the reception of each byte. The device that acknowledges must pull-down the SDA line during the acknowledge-clock pulse, so that the SDA line is stable LOW during the HIGH period of the acknowledge-related clock pulse (set-up and hold times must be taken into consideration). Acknowledgement on the I<sup>2</sup>C Interface is illustrated in Fig 7.



**Fig. 7 Acknowledgement of I<sup>2</sup>C Interface**

## I<sup>2</sup>C INTERFACE PROTOCOL

ST7026 supports command/data write to addressed slaves on the bus.

Before any data is transmitted on the I<sup>2</sup>C Interface, the device, which should respond, is addressed first. Four 7-bit slave addresses (0111000, 0111001, 0111010 and 0111011) are reserved for ST7026. The least significant 2 bits of the slave address is set by connecting I2CMS0 and I2CMS1 to either logic 0 (VSS1) or logic 1 (VDD1).

The I<sup>2</sup>C Interface protocol is illustrated in Fig 8.

The sequence is initiated with a START condition (S) from the I<sup>2</sup>C Interface master, which is followed by the slave address. All slaves with the corresponding address acknowledge in parallel, all the others will ignore the I<sup>2</sup>C Interface transfer. After acknowledgement, one or more command are followed and the status of the addressed slaves is defined. A command word consists of a control byte, which defines Co and A0, and a data byte.

The last control byte is tagged with a cleared bit (i.e. the continuation bit Co). After a control byte with a cleared Co bit, only data byte(s) will follow. The state of the A0 bit defines whether the following data bytes are interpreted as commands or as RAM data. All addressed slaves on the bus also acknowledge the control and data bytes. After the last control byte, either a series of display data bytes or command data bytes may follow (depending on the A0 bit setting).

If the A0 bit of the last control byte is set to logic 1, these data bytes (display data bytes) will be stored in the display RAM at the address specified by the internal data pointer. The data pointer is automatically updated and the data is directed to the intended ST7026 device.

If the A0 bit of the last control byte is set to logic 0, these data bytes (command data byte) will be decoded and the setting of ST7026 will be changed according to the received commands.

Only the addressed slave makes the acknowledgement after each byte. At the end of the transmission the bus master issues a STOP condition (P). If no acknowledge is generated by the master after a byte, the driver stops transferring data to the master.

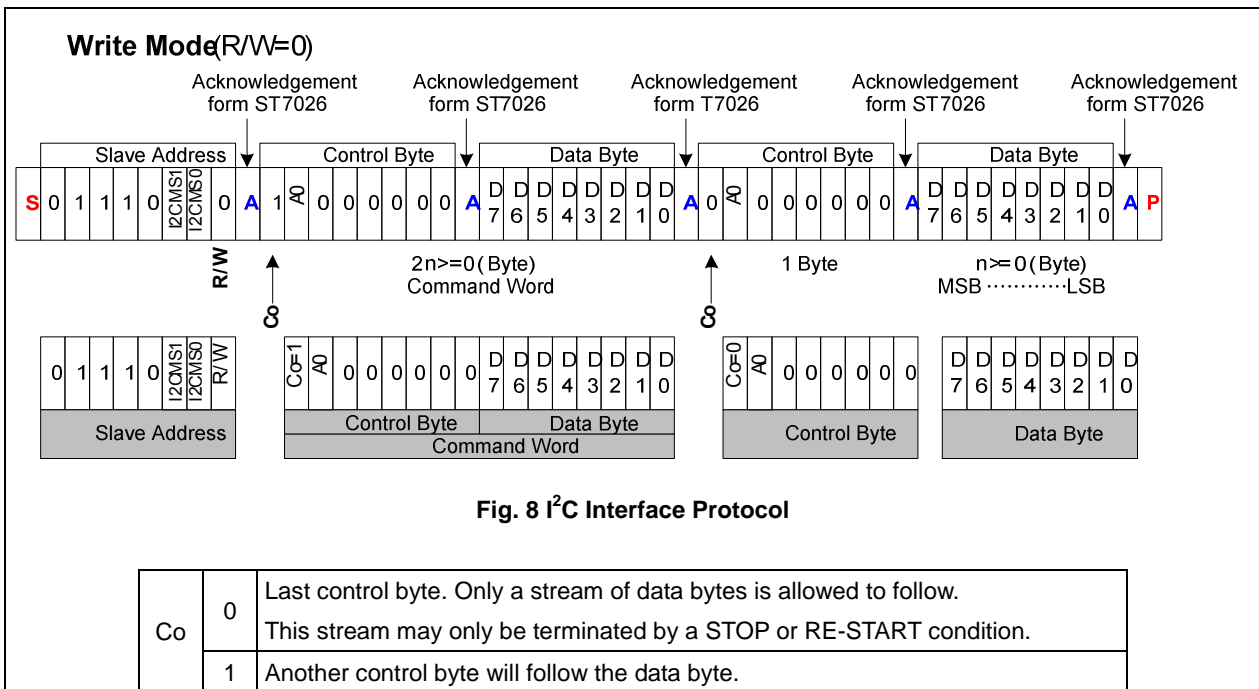





### DISPLAY DATA RAM (DDRAM)

ST7026 contains a 48x4 bit static RAM which stores the display data (the Display Data RAM, DDRAM). It stores the dot-matrix data for the LCD. DDRAM is a 4-row by 48-column addressable array and there is a direct correspondence between X-address and column output number. Each pixel can be selected when the row and column addresses are specified. Since the LCD controller operates independently, data can be written into RAM at the same time as data is being displayed without causing the LCD flicker.

### Data Format & DDRAM Structure

The display data is written through D0 to D7.

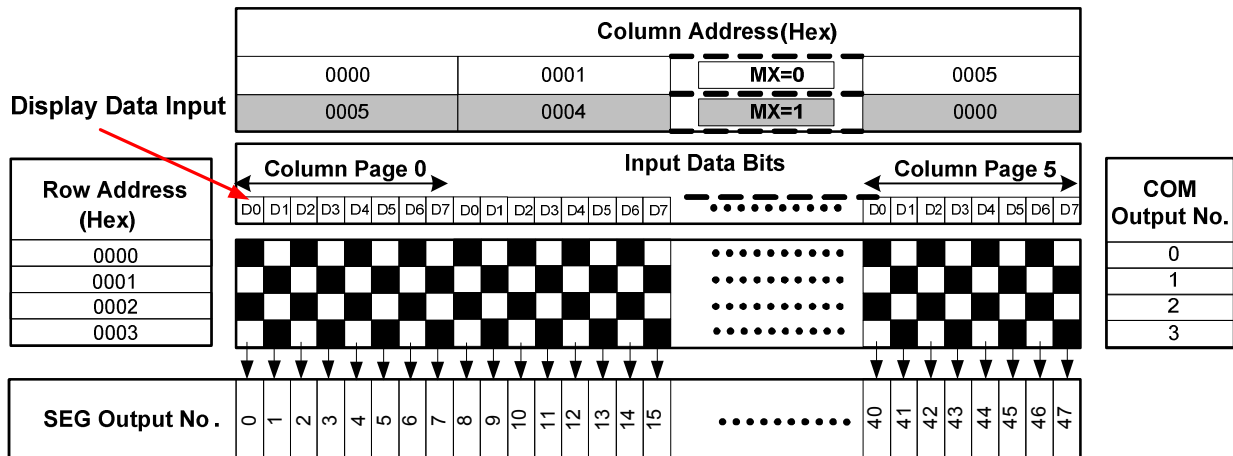

Fig. 11 Data Format and DDRAM Structure

Sometimes, a mirrored DDRAM map is easier for manual data mapping.

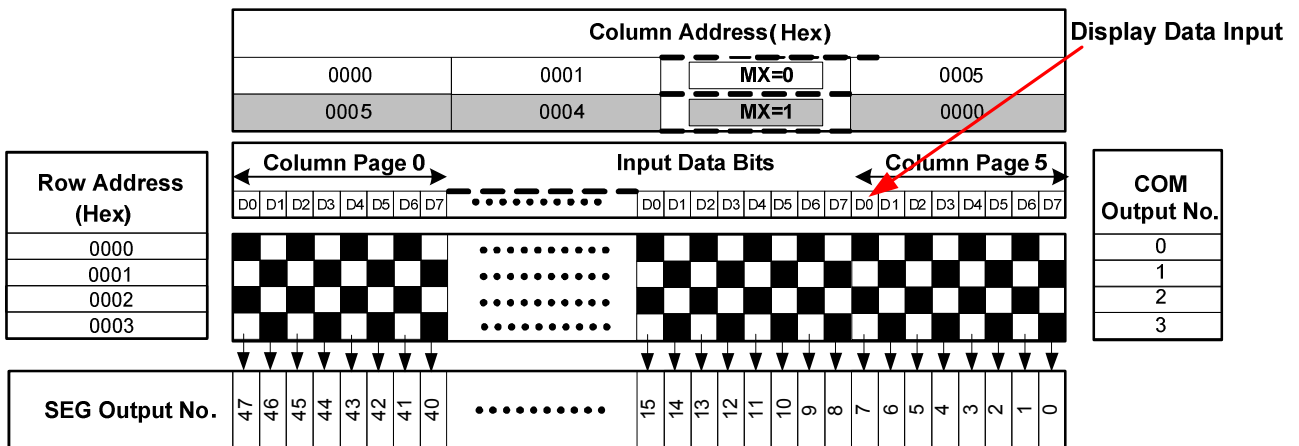

Fig. 12 Transferred DDRAM Map

## Row Address Circuit

Row address circuit has a 4-bit present counter which points to the current row address of DDRAM. The row address can be specified by the Row Address Set command.

## Column Address Circuit

The internal column address circuit has a 4-bit preset counter which points to the current column address of DDRAM. A column address mapping to a “column page” to send 8-bits data information to DDRAM. ST7026 has 6 column pages and the column address is from 0x00 to 0x05. The column addresses can be specified by the Column Address Set command.

## DDRAM Addressing

In order to speed up the throughput of sequential display data transfer, the column address will be increased by 1 automatically after updating 8-bit data. In this way, the Host doesn't have to set column/page address for each data transfer. The column address will be incremented (+1) after receiving each byte of display data. This allows MPU accessing display data continuously. When the column address points to the last column address (0x0B), the next DDRAM access will let the column address return to 0 and the row address will be increased by 1 (points to the next row). If the row address is also the last row (0x08), both of the column address and the row address are returned to 0.

The following example illustrates how to write display data into DDRAM (the pattern is shown in the figure below):

```
Write_command(0x2A); // Column address set
Write_data(0x02); // set start address at 2 (for SEG16 and SEG23)
Write_data(0x04); // set end address at 4 (for SEG32 and SEG39)
Write_command(0x2C); // Memory write
Write_data(0x31); // SEG16, 20, 21 = ON , SEG17, 18, 19, 22, 23 = OFF
```

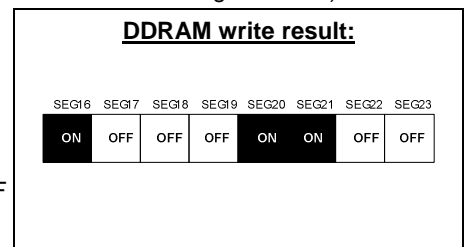

## INTERNAL LCD POWER CIRCUITS

The following figure illustrates the external connection when using internal LCD power circuits. The internal voltage booster can be connected as x2 ~ x4 voltage booster.

Note:

1. The maximum VLCD voltage is 18V. If VDD2 is 5V, x4 booster only support to 18V.
2. Booster is only produced by external connection of capacitances.

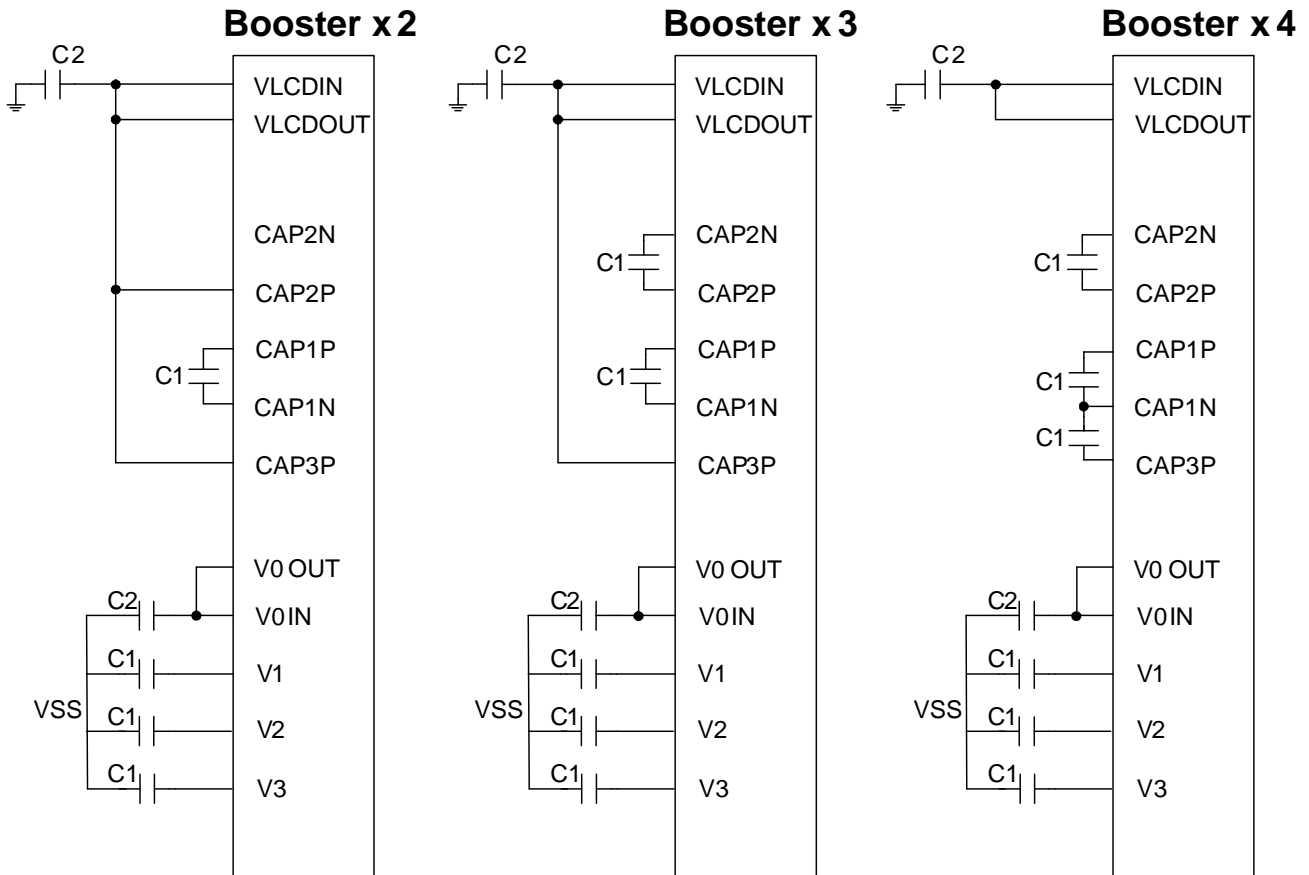
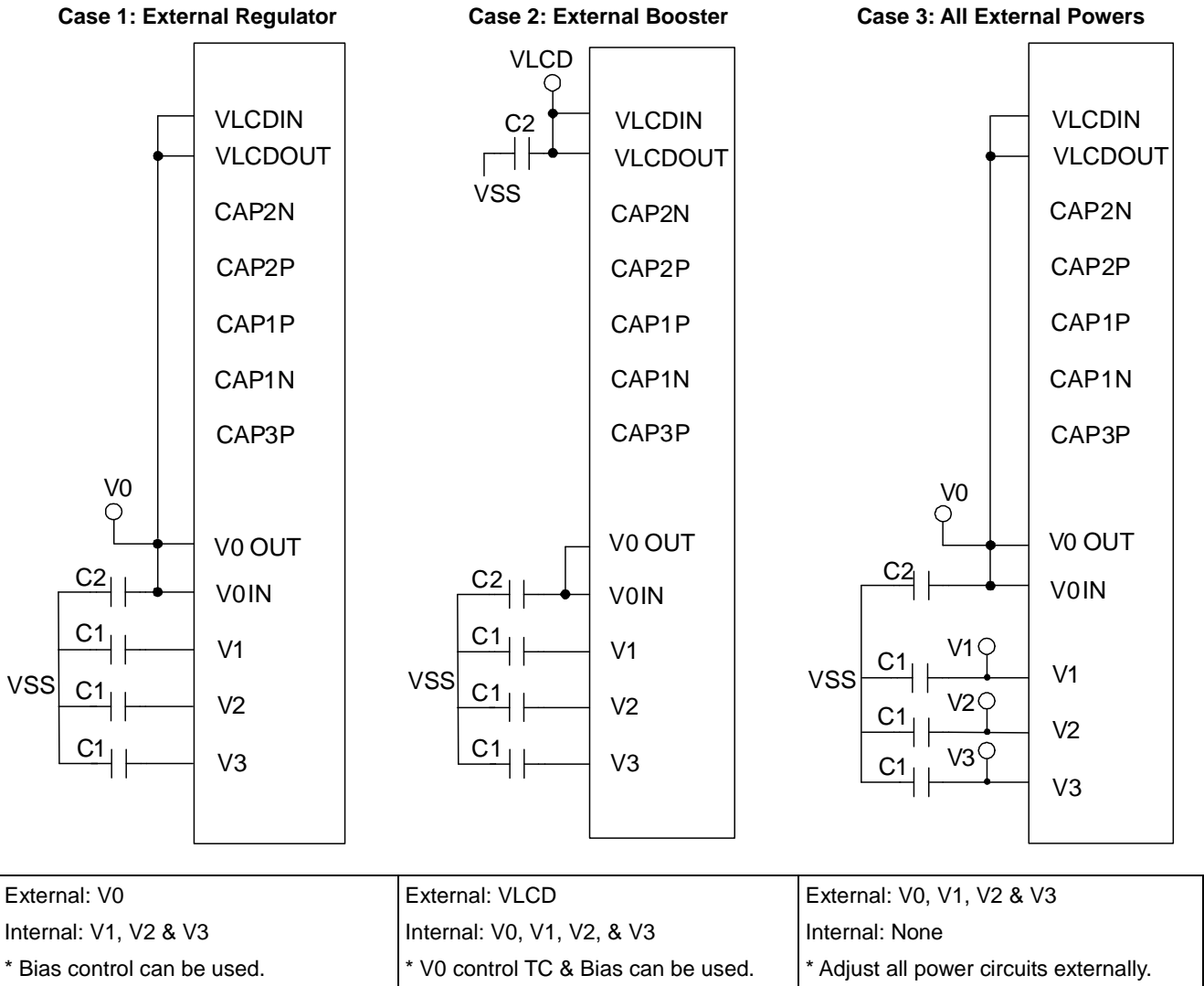

Fig. 13 External Connection for Internal Power Circuits

For external power system, some typical applications are shown below:



**Fig. 14 External Connection for External Power Circuits**

### External Components of Power Circuit

The optimum values of C1 and C2 depend on the loading of LCD panel. The value should be determined by customer. When determining the capacitor value, customer can display a pattern with large loading and then check if the capacitor makes the voltage stable or not. The following table is a quick reference for the initial setting.

Symbol	Reference Value (uF)
C1	1 uF / 25V
C2	4.7 uF / 25V

Note:

1. Please place all these capacitors close to the related pin of IC.
2. If the LCD panel is large or the ITO resistance is not good, the capacitor value maybe large than the reference value. If the value is more than 10uF, customer should consider the following suggestion.
3. When the LCD panel size is large and desired display quality is unavailable by increasing the value of capacitor, it is recommended to use the external power system

## INTERNAL LED BACKLIGHT CONTROL CIRCUIT

### LED Power Switch Pin (LEDPWM)

The built-in LED Backlight Control Circuit generates PWM signal (LEDPWM pin) to control the external LED backlight power circuit (such as VLED booster or VLED power switch).

Please note this pin can not be used to drive LED backlight directly, it is used to switch the external LED backlight power circuit ON/OFF.

### LED PWM Field

In order to achieve the smooth LED backlight control, there are 4 kinds of LED PWM cycles can be chosen. LED PWM cycles could be 1,2,4,8. LED PWM cycles sync with system clock, that means LED PWM cycles occur during COM is triggered. The PWM High/Low ratio is based on the value of LEDRT[7:0], LEDRT[7:0] set the number of "High" cycles in one PWM period. The definition of a frame is defined as the following figure.

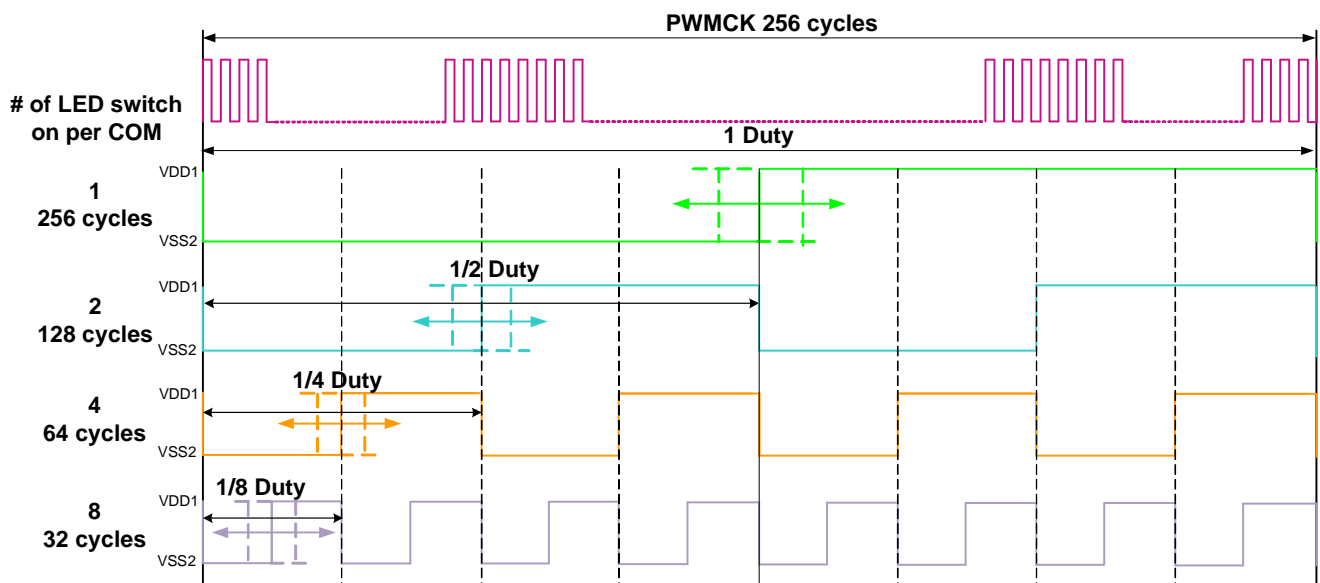

Fig. 15 LED PWM cycles

# of PWM cycles in one COM	Legal LEDRT bits	PWMCK counting # in one PWM period	LEDRT usable range
1	LEDRT[7:0]	256	0~255
2	LEDRT[6:0]	128	0~127
4	LEDRT[5:0]	64	0~63
8	LEDRT[4:0]	32	0~31

## LED Backlight connection

Dependent on different LED backlight circuit, there are two methods to control LED backlight by LEDPWM pin. When LED backlight circuit is parallel connection. LEDPWM connects to a MOS to output High/Low signal to control the LED backlight. When LED backlight circuit is series connection. LEDPWM need to control backlight ON/OFF by a Boost IC. Fig. 16 shows the LEDPWM application circuit for parallel LED connection. Fig. 17 shows the suggestion of LEDPWM application method for series LED connection.

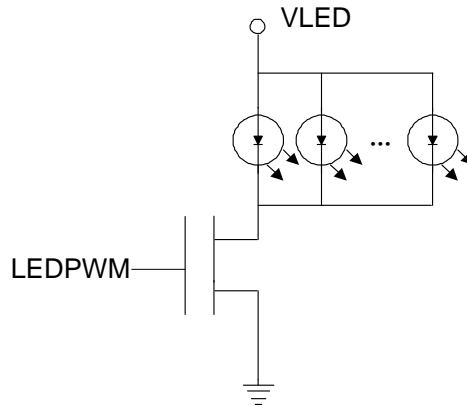

Fig. 16 LEDPWM application for LED parallel connection

Note:

If the ITO resistance of LEDPWM is larger, the RC-delay of the ITO resistance and the Gate-capacitance (the capacitance value is larger for power MOSFET) should be considered.

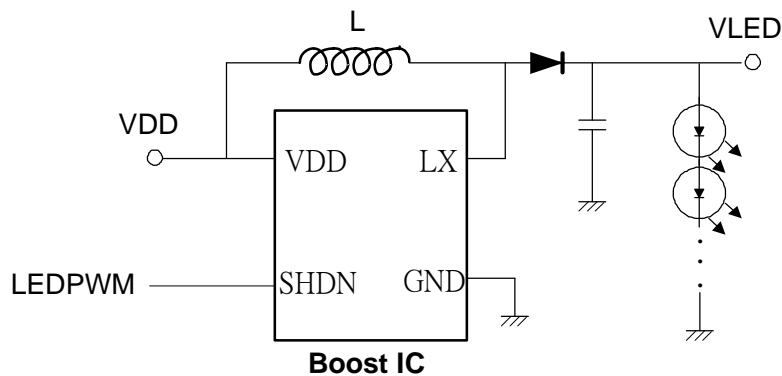

Fig. 17 The suggestion of LEDPWM application for LED Series connection

## Driving Waveform Control

ST7026 supports 2 kinds of driving waveform: A-type and B-type. A-type and B-Type is chosen by TYPMD pin. For different bias setting, the driving voltage is different. The definition of driving waveform as the following figures.

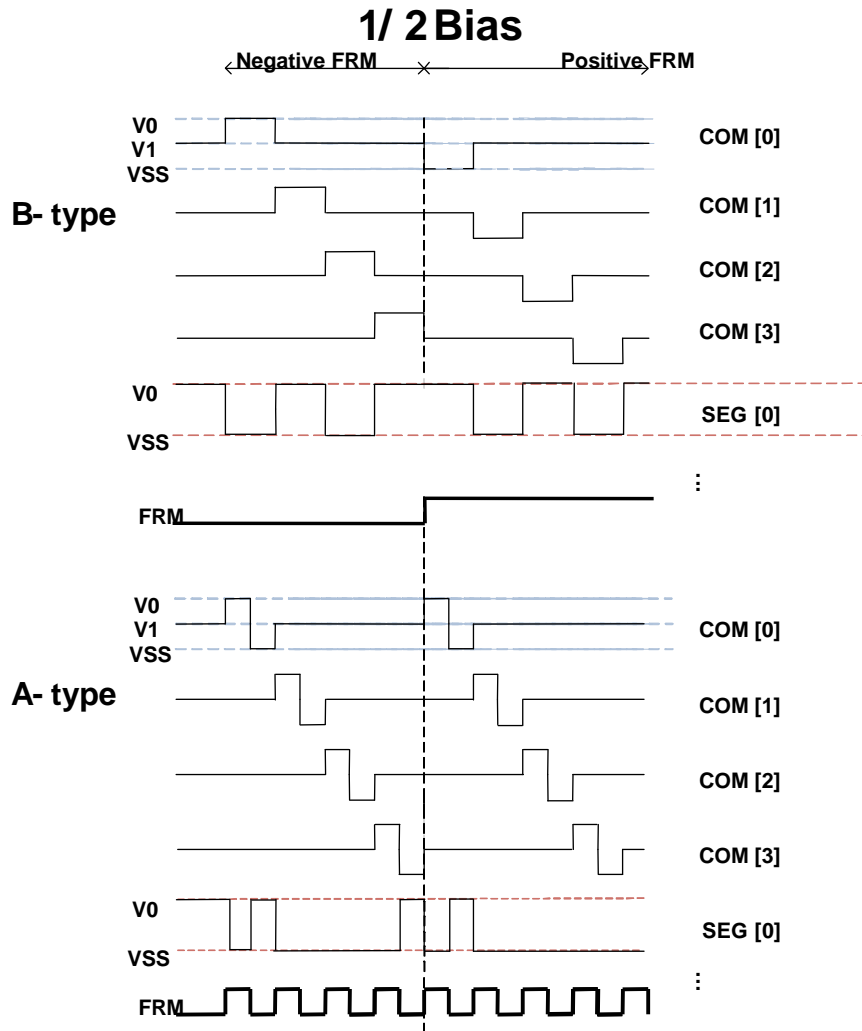

Fig. 18 A-type & B-type of 1/2 Bias waveform

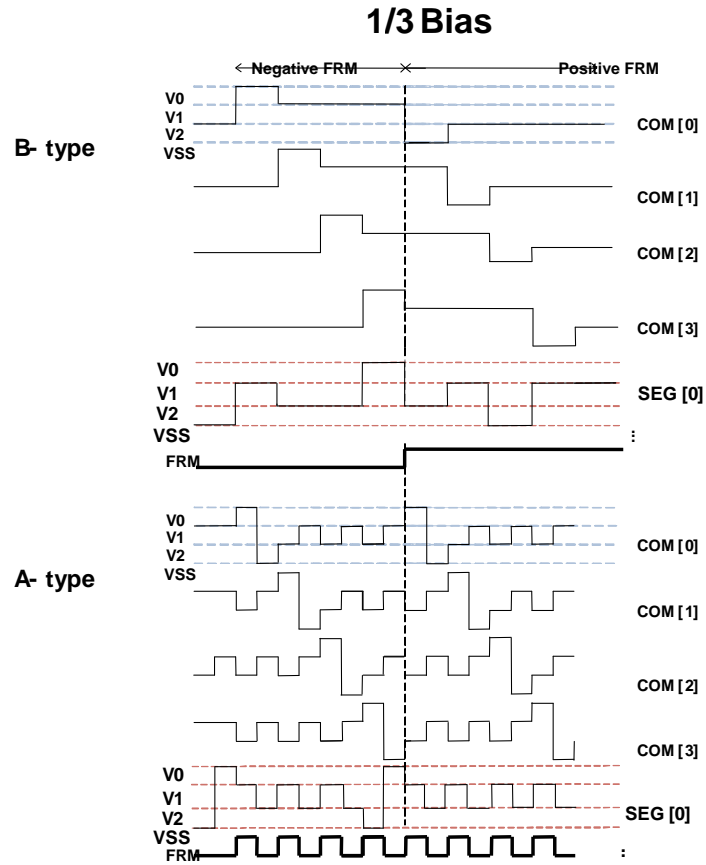

Fig. 19 A-type & B-type of 1/3 Bias waveform



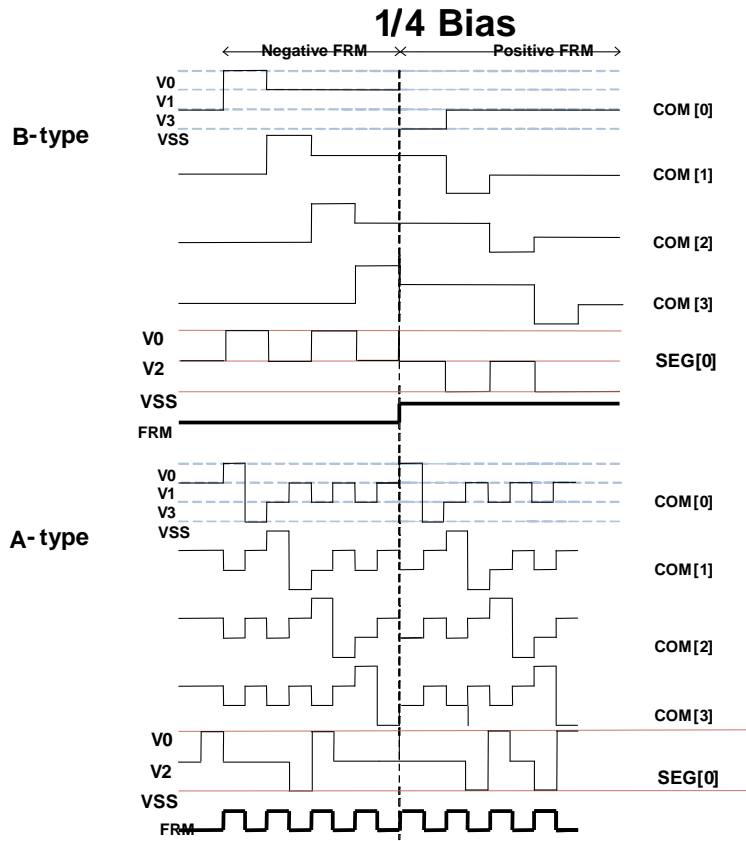

Fig. 20 A-type & B-type of 1/4 Bias waveform

## 8. RESET CIRCUIT

Setting /RST to “L” (hardware reset) can initialize internal function. /RST pin must connect to the reset pin of MPU and initialization by /RST pin is essential before operating. When /RST becomes “L” or “SRESET” instruction is issued, the internal reset procedure will start. The procedure is listed below:

Internal oscillator: OFF

Internal LCD PWM circuits: OFF

Display: OFF (all SEGs/COMs output VSS level)

Display all-point: Exit

Inverse Display: OFF

Row address: 0

Column address: 0

Power control [OSC, BST, FOL, V0] = All OFF

All registers are default value

After power-on, display data in DDRAM is undefined and the display status is “Display OFF”. The contents in DDRAM will not be cleared by internal reset procedure. It’s better to initialize whole DDRAM (ex: fill all 00h or write a display pattern) before turning the Display ON. Besides, the power is not stable at the time which is just turned ON. A hardware reset is needed to initialize those internal registers after the power is stable.

## 9. INSTRUCTION TABLE

### Instruction

Command	Instruction Code										Description
	Hex	A0	D7	D6	D5	D4	D3	D2	D1	D0	
NOP	00	0	0	0	0	0	0	0	0	0	No Operation
SRESET	01	0	0	0	0	0	0	0	0	1	Software reset
Sleep In	10	0	0	0	0	1	0	0	0	0	Enter Sleep-in mode
Sleep Out	11	0	0	0	0	1	0	0	0	1	Exit Sleep-in mode
Inverse Display OFF	20	0	0	0	1	0	0	0	0	0	Display Inversion off
Inverse Display	21	0	0	0	1	0	0	0	0	1	Display Inversion on
Exit All-Pixel ON	22	0	0	0	1	0	0	0	1	0	All-pixel OFF
All-Pixel ON	23	0	0	0	1	0	0	0	1	1	All-pixel ON
Display OFF	28	0	0	0	1	0	1	0	0	0	Display OFF
Display ON	29	0	0	0	1	0	1	0	0	1	Display ON
Set Column Address	2A	0	0	0	1	0	1	0	1	0	Set column address
	-	1	-	-	-	-	CS3	CS2	CS1	CS0	Column start address
	-	1	-	-	-	-	CE3	CE2	CE1	CE0	Column end address
Set Row Address	2B	0	0	0	1	0	1	0	1	1	Set row address
	-	1	-	-	-	-	RS3	RS2	RS1	RS0	Row start address
	-	1	-	-	-	-	RE3	RE2	RE1	RE0	Row end address
Display Data Length	0F	0	0	0	0	0	1	1	1	1	Set display data length before writing DDRAM (3-Line SPI only)
	-	1	DL7	DL6	DL5	DL4	DL3	DL2	DL1	DL0	
Memory Write	2C	0	0	0	1	0	1	1	0	0	Write data into DDRAM
Power Discharge	D0	0	1	1	0	1	0	0	0	0	Power discharge
	-	1	0	0	0	0	0	0	AD1	AD0	
Set Frame Frequency	B2	0	1	0	1	1	0	0	1	0	Set LCD frame frequency
	-	1	0	0	0	1	FR3	FR2	FR1	FR0	
Set LED PWM	B3	0	1	0	1	1	0	0	1	1	Set PWM waveform for LED backlight
	-	1	-	-	-	-	-	0	LP1	LP0	
	-	1	LEDRT[7:0]								
RAM Counter Direction	B7	0	1	0	1	1	0	1	1	1	Set RAM Counter Direction MX
	-	1	-	-	-	-	-	-	0	MX	
Set Vop	C0	0	1	1	0	0	0	0	0	0	Set Vop for contrast control. Range: 4V~18V
	-	1	Vop7	Vop6	Vop5	Vop4	Vop3	Vop2	Vop1	Vop0	
	-	1	0	0	0	0	0	0	0	Vop8	
Set Bias	C3	0	1	1	0	0	0	0	1	1	Select Bias for multi-duty
	-	1	0	0	0	0	0	0	BS1	BS0	
Power Control	D2	0	1	1	0	1	0	0	1	0	Power Control
	-	1	0	0	0	OSC	BST	FOL	V0	0	
Set Booster Clock	BA	0	1	0	1	1	1	0	1	0	Set booster clock
	-	1	-	-	-	-	-	BE2	BE1	BE0	

## 10. INSTRUCTION DESCRIPTION

### NOP (00h)

Non-operation! This instruction is no operation of IC.

A0	D7	D6	D5	D4	D3	D2	D1	D0	Description
0	0	0	0	0	0	0	0	0	No Operation

### SRESET (01h)

This command will trigger internal reset procedure and internal registers will return to default status. The DDRAM contents will not be changed.

A0	D7	D6	D5	D4	D3	D2	D1	D0	Description
0	0	0	0	0	0	0	0	1	Software reset

### Sleep In (10h)

This command causes the LCD module to enter the minimum power consumption mode.

A0	D7	D6	D5	D4	D3	D2	D1	D0	Description
0	0	0	0	1	0	0	0	0	Sleep in mode

### Sleep Out (11h)

This command turns off sleep in mode.

A0	D7	D6	D5	D4	D3	D2	D1	D0	Description
0	0	0	0	1	0	0	0	1	Sleep out mode

### Inverse Display OFF (20h)

This command is used to leave inverse display mode. This command will not change any status or memory data.

A0	D7	D6	D5	D4	D3	D2	D1	D0	Description
0	0	0	1	0	0	0	0	0	Inverse display off (Normal display)

### Inverse Display (21h)

This command is used to enter inverse display mode. This command will not change any status or memory data.

A0	D7	D6	D5	D4	D3	D2	D1	D0	Description
0	0	0	1	0	0	0	0	1	Inverse display on

### Exit All-Pixel ON (22h)

This command is used to exit all display points on mode . This command will not change any status or memory data.

A0	D7	D6	D5	D4	D3	D2	D1	D0	Description
0	0	0	1	0	0	0	1	0	Exit all point on

### All-Pixel ON (23h)

This command is used to enter all display points on mode. This command will not change any status or memory data.

A0	D7	D6	D5	D4	D3	D2	D1	D0	Description
0	0	0	1	0	0	0	1	1	Enter all point on

## Display OFF (28h)

This command is used to enter into display off mode.

A0	D7	D6	D5	D4	D3	D2	D1	D0	Description
0	0	0	1	0	1	0	0	0	Display off

## Display ON (29h)

This command is used to enter into display on mode.

A0	D7	D6	D5	D4	D3	D2	D1	D0	Description
0	0	0	1	0	1	0	0	1	Display on

## Set Column Address (2Ah)

This command defines column start address and end address data will be written. (Available range: 03h~08h)

After setting the column start and end address, the ram window is also decided.

A0	D7	D6	D5	D4	D3	D2	D1	D0	Description
0	0	0	1	0	1	0	1	0	Column address set
1	-	-	-	-	CS3	CS2	CS1	CS0	Column start address
1	-	-	-	-	CS3	CS2	CE1	CE0	Column end address

Please note the formula of row start address is **CS[0:3] = 3 + Column address**

Row end address is **CE[0:3]= 3 + Column address**

Ex : Below command shows the display data write from Column Page 1 to Column Page 3

```
wrins(0x2A);    // Set Column address command
wrdata(0x04);   // Column start address is Column Page 1
wrdata(0x06);   // Column end address is Column Page 3
```

## Set Row address (2Bh)

This command defines Row start address and end address data will be written. (Available range: 00h~03h)

After setting the row start and end address, the ram window is also decided.

A0	D7	D6	D5	D4	D3	D2	D1	D0	Description
0	0	0	1	0	1	0	1	1	Row address set
1	-	-	-	-	-	-	RS1	RS0	Row start address
1	-	-	-	-	-	-	RE1	RE0	Row end address

## Set Display data length (0Fh)

This command defines how many data bytes written to DDRAM. (3-Line SPI only, available range: 00h~17h)

A0	D7	D6	D5	D4	D3	D2	D1	D0	Description
0	0	0	0	0	1	1	1	1	Row address set
1	DL7	DL6	DL5	DL4	DL3	DL2	DL1	DL0	Row start address

The data length calculation formula is data length = DL[7:0]+1

Ex.: DL[7:0] = 0x00 means data length is 1 byte.

DL[7:0] = 0x05 means data length is 5+1=6 bytes.

## Memory Write (2Ch)

This command is executed before write data to memory.

A0	D7	D6	D5	D4	D3	D2	D1	D0	Description
0	0	0	1	0	1	1	0	0	Write data to memory

## Power Discharge (D0h)

This command is discharge IC power before VDD2 off.

A0	D7	D6	D5	D4	D3	D2	D1	D0	Description
0	1	1	0	1	0	0	0	0	Power discharge
1	0	0	0	0	0	0	AD1	AD0	

Flag	Description
AD1	AD1=0: Power discharge off. AD1=1: Discharge VLCDOUT when VDD2 off.
AD0	AD0=0: Power discharge off. AD0=1: Discharge V0 when VDD2 off.

## Set Frame Frequency (B2h)

This command is used to set LCD frame frequency.

A0	D7	D6	D5	D4	D3	D2	D1	D0	Description
0	1	0	1	1	0	0	1	0	Frame frequency set
1	0	0	0	1	FR3	FR2	FR1	FR0	Frame frequency registers set

FR[3:0]				LCD Frame Frequency	FR[3:0]				LCD Frame Frequency
0	0	0	0	50 Hz	1	0	0	0	160 Hz
0	0	0	1	60 Hz	1	0	0	1	180 Hz
0	0	1	0	70 Hz (Default)	1	0	1	0	200 Hz
0	0	1	1	80 Hz	1	0	1	1	220 Hz
0	1	0	0	90 Hz	1	1	0	0	240 Hz
0	1	0	1	100 Hz	1	1	0	1	260 Hz
0	1	1	0	120 Hz	1	1	1	0	295 Hz
0	1	1	1	140 Hz	1	1	1	1	320 Hz

## Set LED PWM (B3h)

This command sets LED PWM waveform which controls external LED switch. LEDRT[7:0] set the number of "High" cycles in one PWM period.

A0	D7	D6	D5	D4	D3	D2	D1	D0	Description
0	1	1	0	1	0-	0	0	0	Set LED PWM
1	-	-	-	-	-	0	LP1	LP0	# of LED switch on per Com setting
1	LEDRT[7:0]							Set LED PWM Field width	

LP1	LP0	LED On/Off numbers in one duty	Legal LEDRT bits	PWMCK counting # in one PWM period	LEDRT usable range
0	0	1 (default)	LEDRT[7:0]	256	0~255 (Default 80h)
0	1	2	LEDRT[6:0]	128	0~127 (Default 00h)
1	0	4	LEDRT[5:0]	64	0~63 (Default 00h)
1	1	8	LEDRT[4:0]	32	0~31 (Default 00h)

## Set RAM Counter Direction (B7h)

This command is used to set RAM counter direction.

A0	D7	D6	D5	D4	D3	D2	D1	D0	Description
0	1	0	1	1	0	1	1	1	Set RAM counter direction
1	-	-	-	-	-	-	0	MX	MX: RAM counter direction

Flag	Description
MX	MX=0: Column Page 0 to Column Page 5 (Default) MX=1: Column Page 5 to Column Page 0 Please re-send DDRAM data after change MX logic.

## Set Vop (C0h)

This command is used to set the LCD supply voltage V0 (Vop). Please note the maximum voltage level of Vop that can be generated is limited by VLCD voltage level and the loading of LCD module.

Please note: The minimum setting of Vop = VDD2 – 1.2V

A0	D7	D6	D5	D4	D3	D2	D1	D0	Description
0	1	1	0	0	0	0	0	0	Vop set
1	Vop7	Vop6	Vop5	Vop4	Vop3	Vop2	Vop1	Vop0	Set the registers of Vop
1	-	-	-	-	-	-	-	Vop8	Vop[8:0]=64h (Default) Range: 4~18V

The Vop calculation formula is:  $V0 = a + (Vop[8:0]) \times b$

Vop will keep 18V when Vop[8:0] > 15Eh

Symbol	Value	Unit
a	4	V
b	0.04	V

Ex: Vop[8:0] = 01100100 (64H)

$V0 = 4 + 100 \times 0.04 = 8V$

## Set Bias (C3h)

This command is used to select LCD bias ratio of the voltage required to drive LCD.

A0	D7	D6	D5	D4	D3	D2	D1	D0	Description
0	1	1	0	0	0	0	1	1	Bias selection
1	0	0	0	0	0	0	BS1	BS0	Set the registers of bias

BS	BS	Bias Value
0	0	1/2 bias
0	1	1/3 bias
1	0	1/4 bias (Default)
1	1	



## Power Control (D2h)

This command is used to set power register.

A0	D7	D6	D5	D4	D3	D2	D1	D0	Description
0	1	1	0	1	0	0	1	0	Power Control
1	0	0	0	OSC	BST	FOL	V0	0	

Flag	Set to '0'	Set to '1'
OSC	OSC on	OSC off (Default)
BST	Booster on	Booster off (Default)
FOL	Follower on	Follower off (Default)
V0	V0 regulator on	V0 regulator off (Default)

## Set Booster Clock (BAh)

This command is used to set booster clock.

Please note different frame rate and duty have different BOSC clock. Please find the mapping BOSC clock and set BE[2:0] from the below table will get booster clock. The available value of booster is between 15KHz~40KHz.

A0	D7	D6	D5	D4	D3	D2	D1	D0	Description
0	1	0	1	1	1	0	1	0	Set booster clock
1	-	-	-	-	-	BE2	BE1	BE0	

BE2	BE1	BE0	Booster Clock (KHz)
0	0	0	BOSC / 3
0	0	1	BOSC / 4
0	1	0	BOSC / 5
0	1	1	BOSC / 6
1	0	0	BOSC / 8
1	0	1	BOSC / 12
1	1	0	BOSC / 16
1	1	1	BOSC / 24

# ST7026

BOSC (KHz)		Duty			
		1	2	3	4
Frame rate (Hz)	50	102.4	102.4	115.2	102.4
	60	122.88	122.88	138.24	122.88
	70	143.36	143.36	161.28	143.36
	80	163.84	163.84	184.32	163.84
	90	184.32	184.32	207.36	184.32
	100	204.8	204.8	230.4	204.8
	120	245.76	245.76	276.48	245.76
	140	286.72	286.72	322.56	286.72
	160	327.68	327.68	368.64	327.68
	180	368.64	368.64	414.72	368.64
	200	409.6	409.6	460.8	409.6
	220	450.56	450.56	506.88	450.56
	240	491.52	491.52	552.96	491.52
	260	532.48	532.48	599.04	532.48
	295	573.44	573.44	645.12	573.44
320	614.4	614.4	691.2	614.4	

Ex: Frame rate is 70Hz, duty is 4. The mapping BOSC is 143.36 KHz.

Booster clock as below:

BE2	BE1	BE0	Booster Clock (KHz)
0	0	0	47.79
0	0	1	35.84
0	1	0	28.67
0	1	1	23.89
1	0	0	20.48
1	0	1	17.92
1	1	0	15.93
1	1	1	14.34

The available booster clock range is from 15KHz to 40KHz, please choose 15.93, 20.48, 23.89, 28.67, 35.84, KHz as booster clock.

## 11. OPERATION FLOW

### (1) Initial Flow (with built-in Power Circuits)

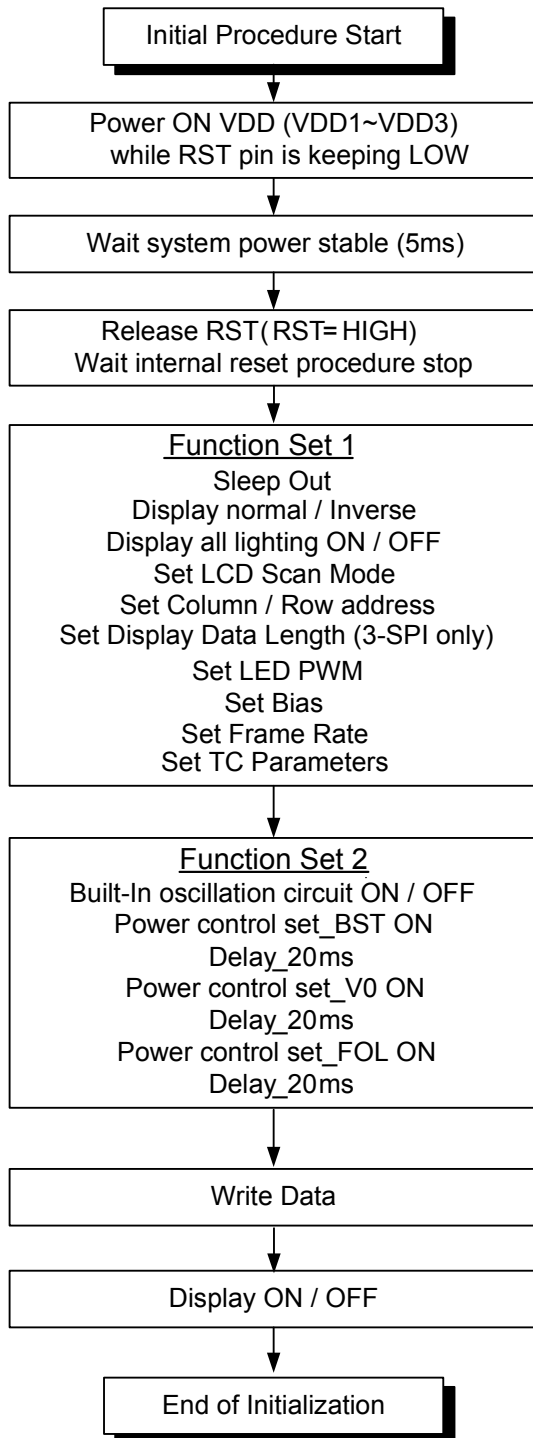

### Power ON and Initial Flow Notes:

1. To prevent power ON noise, please hold RST LOW until the system power is stable (generally 5ms)
2. After releasing RST signal (RST=High), do NOT issue instruction immediately. An internal reset time (tR) is required for finishing internal reset procedure.
3. The delay time for Power Control flow depends on LCD module. The delay time should be increased if the ITO resistance or capacitor value increases.
4. The build-in DDRAM content is unknown after power ON. The content cannot be reset by hardware or software reset. It is recommended to add a DDRAM initial flow to prevent unexpected display pattern after turning ON the display.

## (2) Power OFF Flow

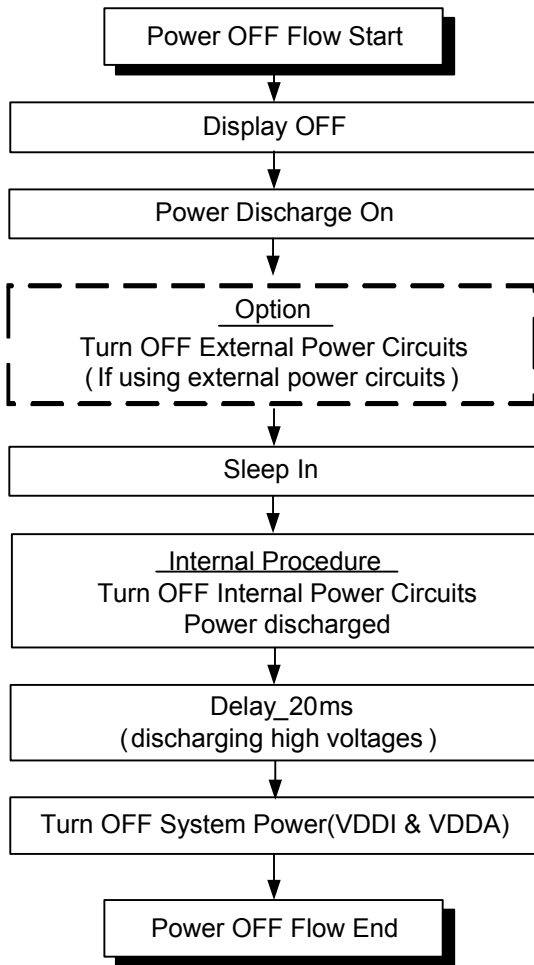

### Power OFF Flow Notes:

1. Be Sure "Power Discharge" is turn on before issuing "Sleep In" instruction.
2. For external power application, please issue discharge instruction after turning external power circuit OFF.

## (3) Sleep Out Flow

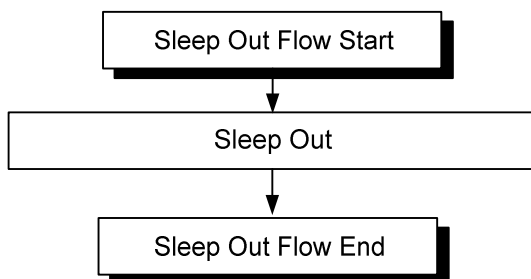

### Sleep Out Flow Notes:

1. After issue "Sleep Out" instruction, oscillator and power system will automatically return to the states before issuing the "Sleep In" instruction.

## (4) Sleep In Flow

### Internal Power Circuits

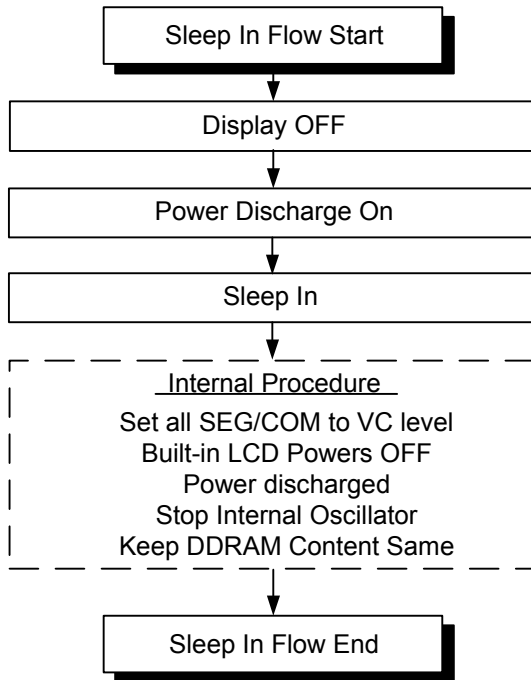

### Internal Power Circuits Sleep In Flow Notes:

1. Be Sure "Power Discharge" is turn on before issuing "Sleep In" instruction.

### External Power Circuits

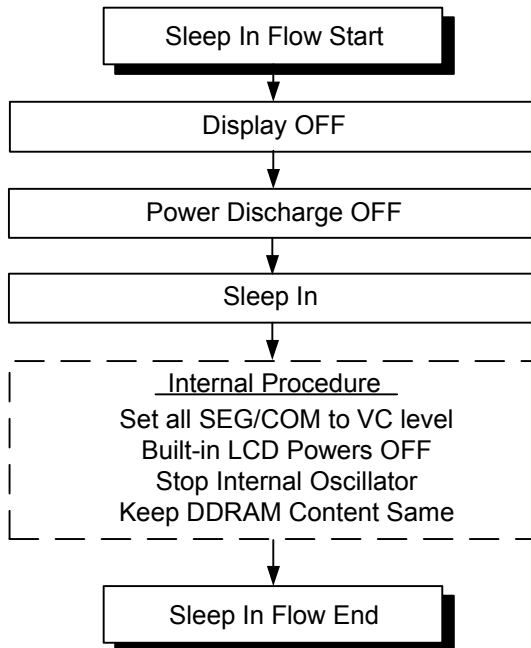

### External Power Circuits Sleep In Flow Notes:

1. Be Sure "Power Discharge" is turn off before issuing "Sleep In" instruction.

**Example initial code:**

Initial Code	For Master/Slave Mode	
	Master	Slave
wrins(0x11); // sleep out	wrins_m(0x11); // sleep out	wrins_s(0x11); // sleep out
wrins_m(0xB7); // LCD Scan set wrddata(0x00); // MX=0	wrins_m(0xB7); // LCD Scan set wrddata(0x00); // MX=0	wrins_s(0xB7); // LCD Scan set wrddata(0x00); // MX=0
wrins(0xC0); // set Vop wrddata(0x32); // set Vop 6V wrddata(0x00);	wrins_m(0xC0); // set Vop wrddata_m(0x32); // set Vop 6V wrddata_m(0x00);	
wrins(0xC3); // set Bias wrddata(0x01); // set 1/3 Bias	wrins_m(0xC3); // set Bias wrddata_m(0x01); // set 1/3 Bias	wrins_s(0xC3); // set Bias wrddata_s(0x01); // set 1/3 Bias
wrins(0xB3); // set LED waveform wrddata(0xFF); // set LED width 0xFF	wrins(0xB3); // set LED waveform wrddata(0xFF); // set LED width 0xFF	
wrins(0x2A); // set SEG address wrddata(0x03); // set Start at SEG0 wrddata(0x0B); // set End at SEG47	wrins(0x2A); // set SEG address wrddata(0x03); // set Start at SEG0 wrddata(0x0B); // set End at SEG47	wrins(0x2A); // set SEG address wrddata(0x03); // set Start at SEG0 wrddata(0x0B); // set End at SEG47
wrins(0x2B); // set COM address wrddata(0x00); // set Start at COM0 wrddata(0x03); // set Start at COM3	wrins(0x2B); // set COM address wrddata(0x00); // set Start at COM0 wrddata(0x03); // set Start at COM3	
wrins(0xB2); // set fFR wrddata(0x13); // set fFR=80Hz	wrins(0xB2); // set fFR wrddata(0x13); // set fFR=80Hz	wrins(0xB2); // set fFR wrddata(0x13); // set fFR=80Hz
wrins(0xD2); // set power control wrddata(0x06); // OSC & Booster on delay_ms(20); // delay 20ms wrins(0xD2); // set power control wrddata(0x04); // V0 on delay_ms(20); // delay 20ms wrins(0xD2); // set power control wrddata(0x00); // FOL on delay_ms(20); // delay 20ms	wrins(0xD2); // set power control wrddata(0x06); // OSC & Booster on delay_ms(20); // delay 20ms wrins(0xD2); // set power control wrddata(0x04); // V0 on delay_ms(20); // delay 20ms wrins(0xD2); // set power control wrddata(0x00); // FOL on delay_ms(20); // delay 20ms	wrins_s(0xD2); // set power control wrddata_s(0x1E); // power all off
wrins(0x0F); // set data length (3-SPI only) wrddata(0x6B); // full range Wrins(0x2C); // Memory Write wr_pattern(0x00); // DDRAM data (black) wrins(0x29); // Display on	wrins(0x0F); // set data length (3-SPI only) wrddata(0x6B); // full range Wrins(0x2C); // Memory Write wr_pattern(0x00); // DDRAM data (black) wrins_m(0x29); // Display on	wrins(0x0F); // set data length (3-SPI only) wrddata(0x6B); // full range Wrins(0x2C); // Memory Write wr_pattern(0x00); // DDRAM data (black) wrins_m(0x29); // Display on

## 12. ABSOLUTE MAXIMUM VALUES

In accordance with the Absolute Maximum Rating System; see notes 1 and 2.

Parameter	Symbol	Conditions	Unit
Digital Power Supply Voltage	VDD1 & VDD3	-0.3 ~ 6	V
Analog Power Supply Voltage	VDD2	-0.3 ~ 6	V
LCD Power Supply Voltage 1	V0 ,VLCD	-0.3 ~ 22	V
LCD Power Supply Voltage 2	V1, V2, V3	-0.3 ~ 22	V
MPU Interface Input Voltage	V <sub>IN</sub>	-0.3 ~ VDDI+0.3	V
MPU Interface Output Voltage	V <sub>O</sub>	-0.3 ~ VDDI+0.3	V
Operating Temperature	T <sub>OPR</sub>	-30 to +85	°C
Storage Temperature	T <sub>STR</sub>	-55 to +105	°C

### Notes

1. Stresses above those listed under Limiting Values may cause permanent damage to the device.
2. Parameters are valid over operating temperature range unless otherwise specified. All voltages are with respect to VSS unless otherwise noted.
3. Insure that the voltage levels of V1, V2 & V3 are always such that:  
 $V0 \geq V1 \geq V2 \geq V3 \geq VSS$

## 13. HANDLING

Inputs and outputs are protected against electrostatic discharge in normal handling. However, to be totally safe, it is desirable to take normal precautions appropriate to handling MOS devices.

## 14. DC CHARACTERISTICS

Unless otherwise specified, VSS=0V and Ta=25°C.

Item	Symbol	Condition	Rating			Unit	Related Pin
			Min.	Typ.	Max.		
Digital Operating Voltage	VDDI		2.7	-	5.5	V	VDD1 VDD3
Analog Operating Voltage	VDDA		2.7	-	5.5		VDD2
High-level Input Voltage	V <sub>IH</sub>		0.8*VDD1	-	VDD1		*1
Low-level Input Voltage	V <sub>IL</sub>		VSS1	-	0.2*VDD1		*1
High-level Output Voltage	V <sub>OH</sub>		0.8*VDD1	-	VDD1		*2
Low-level Output Voltage	V <sub>OL</sub>		VSS1	-	0.2*VDD1		*2
Input leakage current	I <sub>LI</sub>	V <sub>IN</sub> =VDD or VSS	-	-	0.1	uA	*1
Liquid Crystal Driver ON Resistance	R <sub>ON</sub>	Ta=25°C, ΔV=10% V0=8.0V, Bias = 1/3	-	2	-	KΩ	SEGn COMn
			-	2	-		
Frame frequency	f <sub>FR</sub>	FR[3:0]=0x02, T=25°C, Duty=1/8	-	70	-	Hz	
Regulator Supply Voltage Booster Output Voltage	VLCD		-	-	20	V	VLCD *3
LCD Vop	V0	VDD=3.3V	4	6	18		
		VDD=5V	5				

### Notes

1. Related Pin: IF, SDA, SCK, /RST, /CS, CLS, SYNC, DON & CL, PRT0, PRT1, TYPMD, MS
2. Related Pin: SDA, SYNC, DON & CL.
3. Insure that the voltage levels of V0 is always such that: VLCD -0.5 ≥ V0.
4. The maximum possible V0 voltage that may be generated is dependent on voltage, temperature and (display) load.

The DC Current Consumption of bare chip is shown below: (with internal power circuits and internal clock)

Test pattern	Symbol	Condition	Rating			Units	Note
			Min.	Typ.	Max.		
Display Pattern SNOW	ISS	VDD=5.0V, Booster x4, FR=70Hz, V0=8V, Ta=25°C	-	550	-	uA	
Sleep In Mode	ISS	VDD=5.0V, Booster x4, FR=70Hz, V0=8V, Ta=25°C	-	50	-	uA	



## 15. AC CHARACTERISTICS

### SPI 3-LINE SERIAL INTERFACE TIMING

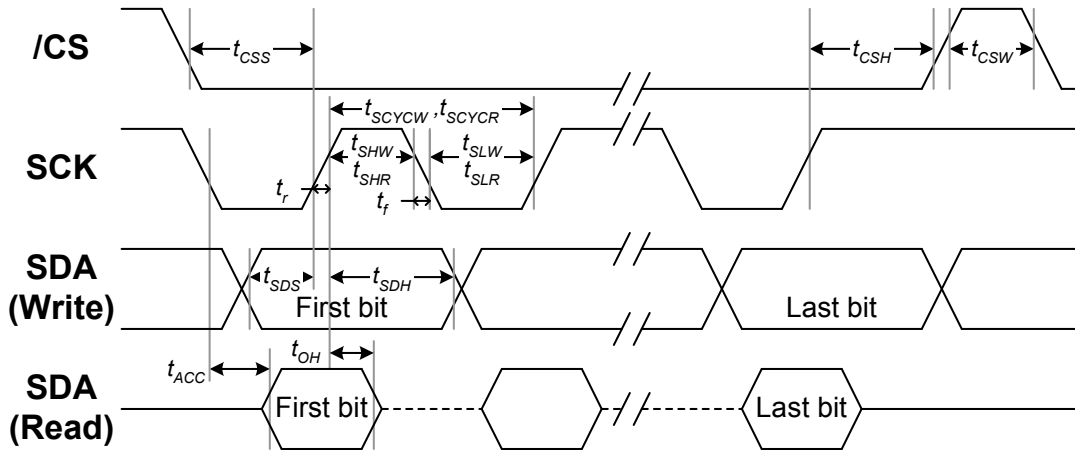

(VDD1=3-5.5V Ta=25°C)

Item	Signal	Symbol	Condition	Min.	Max.	Unit
Serial clock period (Write)	SCK	$t_{SCYCW}$		250	—	ns
SCK "H" pulse width		$t_{SHW}$		100	—	
SCK "L" pulse width		$t_{SLW}$		100	—	
Serial clock period (Read)		$t_{SCYCR}$		250	—	
SCK "H" pulse width		$t_{SHR}$		100	—	
SCK "L" pulse width		$t_{SLR}$		150	—	
Data setup time	SDA	$t_{SDS}$		100	—	
Data hold time		$t_{SDH}$		100	—	
Read data access time		$t_{ACC}$		40	100	
Read data hold time		$t_{OH}$		10	35	
Chip select setup time	/CS	$t_{CSS}$		150	—	
Chip select hold time		$t_{CSH}$		150	—	
Chip select wait time		$t_{CSW}$		20	—	

\*1 The input signal rise and fall time ( $t_r$ ,  $t_f$ ) are specified at 15 ns or less.

\*2 All timing is specified using 20% and 80% of VDD as the standard.

## I<sup>2</sup>C INTERFACE TIMING

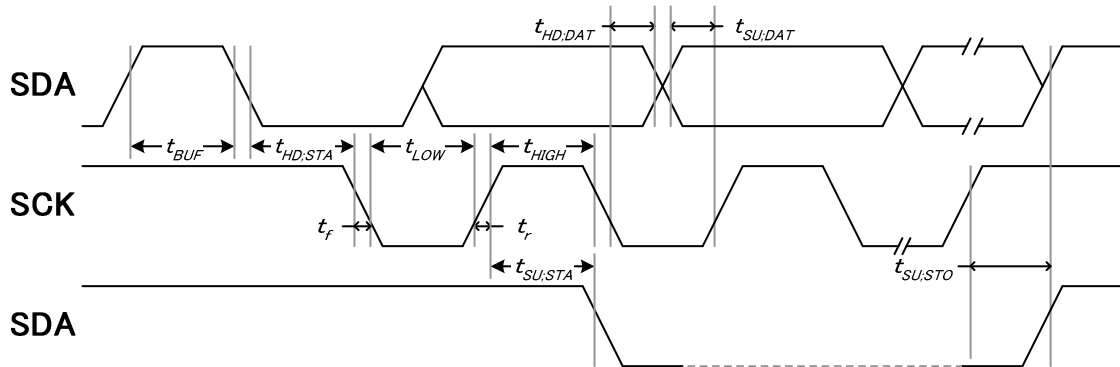

(VDD=2.7~5.5V, Ta=25°C)

Item	Signal	Symbol	Condition	Min.	Max.	Unit
Serial clock frequency	SCK	fSCL		-	400	KHz
SCL clock LOW period		tLOW		1.3	-	
SCL clock HIGH period		tHIGH		0.6	-	
BUS free time between a STOP and START		tBUF		1.3	—	
Data setup time	SDA	tSU;Data		0.1	—	us
Data hold time		tHD;Data		0.02	—	
Setup time for a repeated START condition		tSU;STA		0.6	—	
Start condition hold time		tHD;STA		0.6	—	
Setup time for STOP condition		tSU;STO		0.6	—	
Signal rise time (Min: C <sub>L</sub> =40pF; Max: C <sub>L</sub> =400pF)	SDA	t <sub>r</sub>		—	300	ns
Signal fall time (Min: C <sub>L</sub> =40pF; Max: C <sub>L</sub> =400pF)	SCK	t <sub>f</sub>		—	300	
Tolerable spike width on bus	SCK	t <sub>SW</sub>		—	15	

\*1 All timing is specified using 20% and 80% of VDD as the standard.

## RESET TIMING

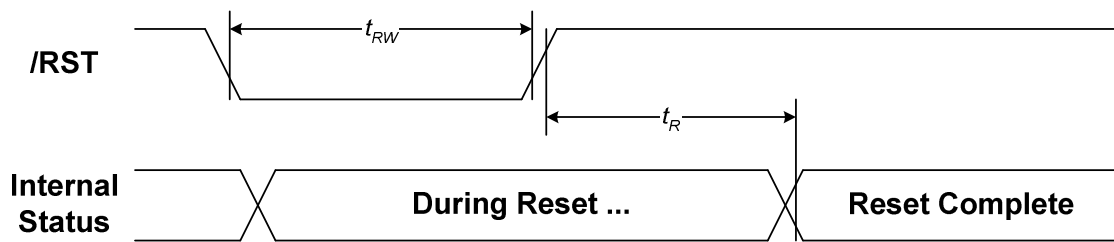

(VDD=2.7~5.5V Ta=25°C)

Item	Symbol	Condition	Min.	Max.	Unit
Reset time	t <sub>R</sub>		-	2	us
Reset "L" pulse width	t <sub>RW</sub>		2.5	-	

\*1 The rise and fall time (t<sub>r</sub>, t<sub>f</sub>) input signal are specified at 15 ns or less.

\*2 All timings take 20% and 80% of VDD as standard.

## APPLICATION NOTE

### Application Circuit for 3-Line SPI Interface

Oscillator : Internal  
 LCD Power: Internal  
 Booster: x3  
 Duty: 4  
 B-type

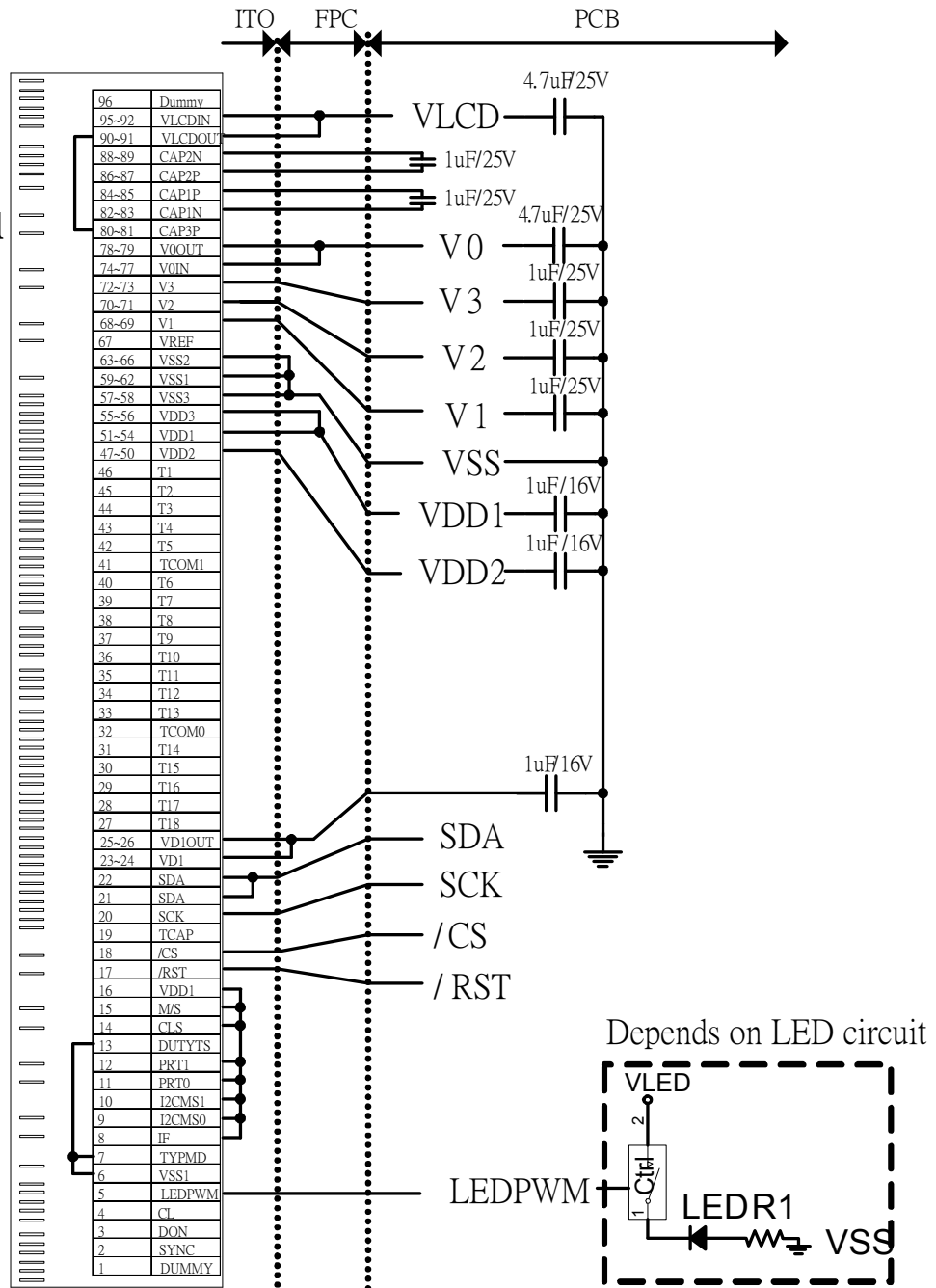

## Application Circuit for I<sup>2</sup>C Interface

Oscillator: Internal  
 LCD Power: Internal  
 Booster: x3  
 Duty: 4  
 B-type  
 I2C address: 0111011

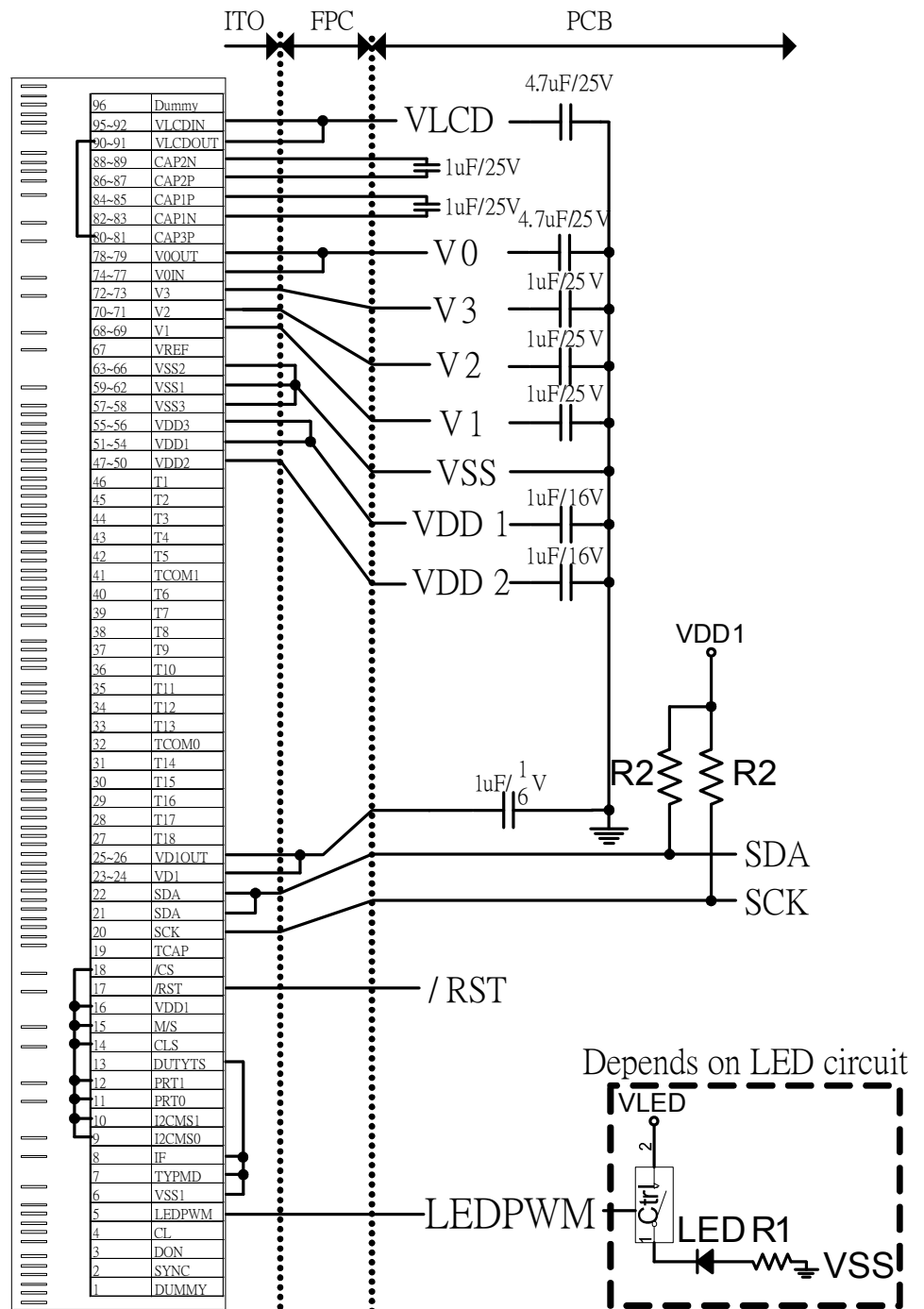

## Application Circuit for 3-Line SPI Interface Master/Slave

Oscillator: External  
 LCD Power: External  
 Duty: 4  
 B-type

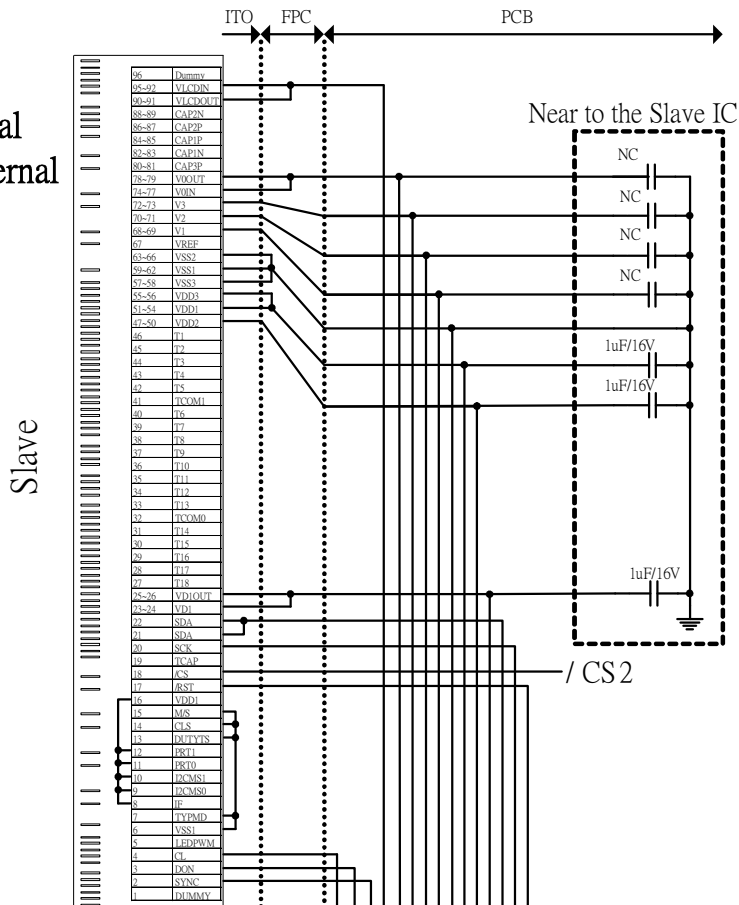

Oscillator: Internal  
 LCD Power: Internal  
 Booster: x3  
 Duty: 4  
 B-type

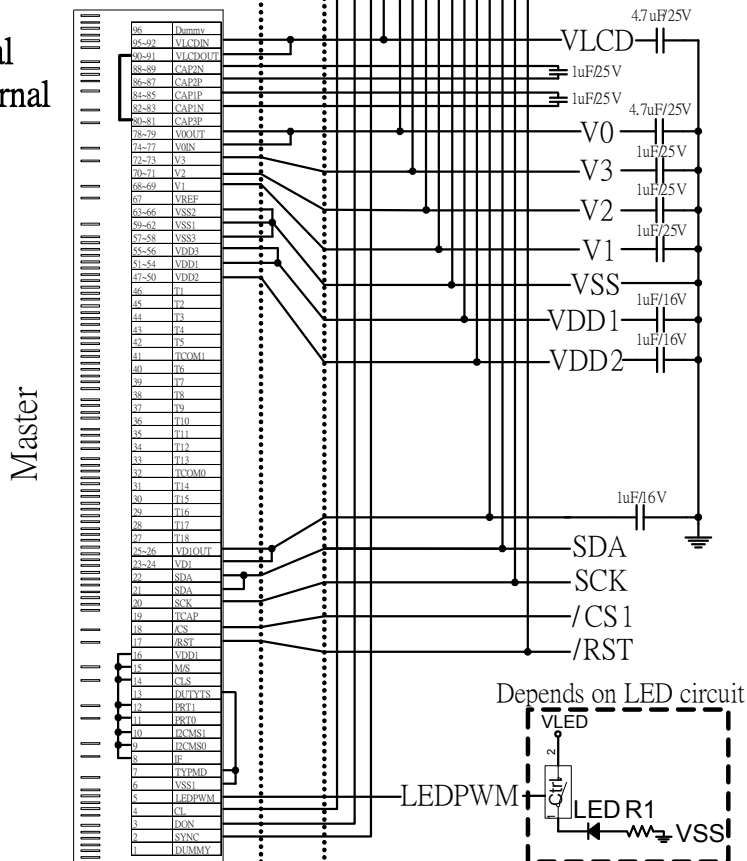

## Application Circuit for I<sup>2</sup>C Interface Master/Slave

Oscillator : External  
 LCD Power : External  
 Duty : 4  
 B-type  
 I2C address : 0111000

Slave

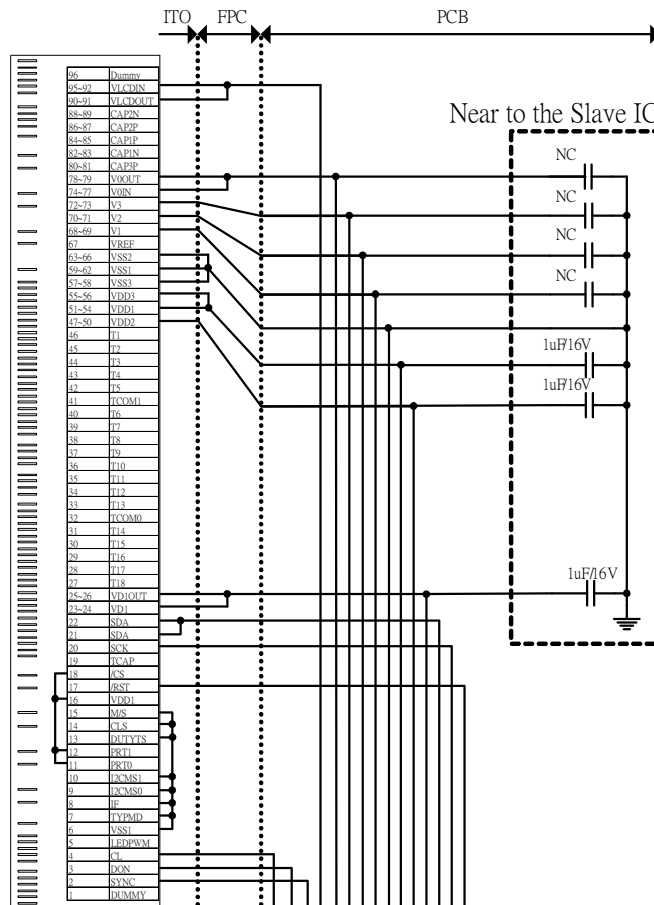

Oscillator : Internal  
 LCD Power : Internal  
 Booster : x3  
 Duty : 4  
 B-type  
 I2C address : 0111011

Master

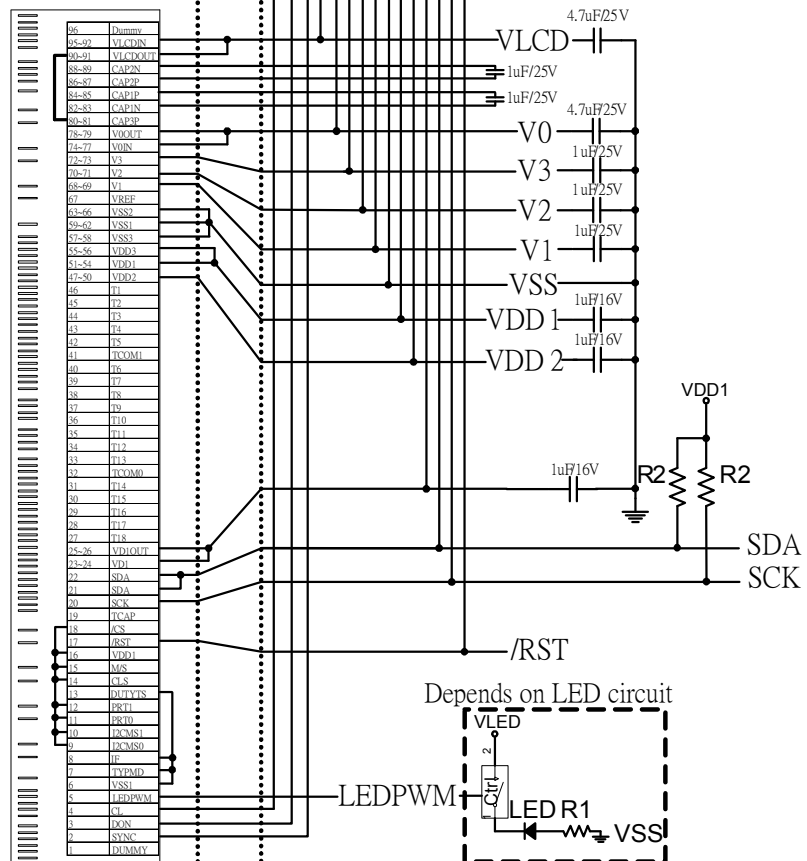

<b>Revision History</b>		
<b>Version</b>	<b>Date</b>	<b>Description</b>
0.1	2011/12/15	<ul style="list-style-type: none"><li>● Preliminary Version</li></ul>
0.2	2012/10/19	<ul style="list-style-type: none"><li>● Modify Frame Rate Value</li><li>● Modify LCD Driver Pins description</li><li>● Modify Driving waveform</li><li>● Modify initial code</li><li>● Add Operation Flow</li><li>● Modify Application Circuit</li></ul>
0.3	2012/11/26	<ul style="list-style-type: none"><li>● Modify Power Supply Pins description.</li></ul>
1.0	2013/05/09	<ul style="list-style-type: none"><li>● Modify operating temperature range.</li></ul>
1.1	2013/12/11	<ul style="list-style-type: none"><li>● Modify set row address &amp; set column address description.</li><li>● Modify /CS pin description.</li></ul>
1.2	2013/12/23	<ul style="list-style-type: none"><li>● Modify External-power drawing</li></ul>
1.2a	2014/05/13	<ul style="list-style-type: none"><li>● Modify the typing error</li></ul>
1.3	2014/06/26	<ul style="list-style-type: none"><li>● Modify External-power drawing</li></ul>