

## 24 V input, 170 °C high temperature, 25 mA LDO linear regulator

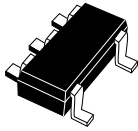

SOT323-5L

[Maturity status link](#)

ST716

### Features

- No embedded thermal protection  
- see section 5.2 for thermal management
- Temperature range: from -40 °C to 170 °C
- 2.5 V to 24 V input voltage
- Low-dropout voltage (500 mV typ. at 25 mA)
- Very low quiescent current (3.8  $\mu$ A typ. at full load)
- 25 mA guaranteed output current
- Output voltages 3.3 V
- Compatible with ceramic output capacitors from 0.47  $\mu$ F to 10  $\mu$ F
- Internal current limit
- Packages: SOT323-5L

### Applications

- Oil and Gas
- Down-hole perforation
- Industrial

### Description

The **ST716** is a high voltage, ultra low quiescent current and low drop linear regulator capable of providing an output current in excess of 25 mA.

The device operates over an input voltage range from 2.5 V to 24 V, and is stable with output ceramic capacitors. Fault condition protection includes short-circuit current limitation. The ultra low quiescent current of 3.8  $\mu$ A at full load makes it highly suitable for low power applications and battery-powered systems. The **ST716** is available in SOT323-5L.

# 1 Schematic diagram

Figure 1. Block diagram - fixed version

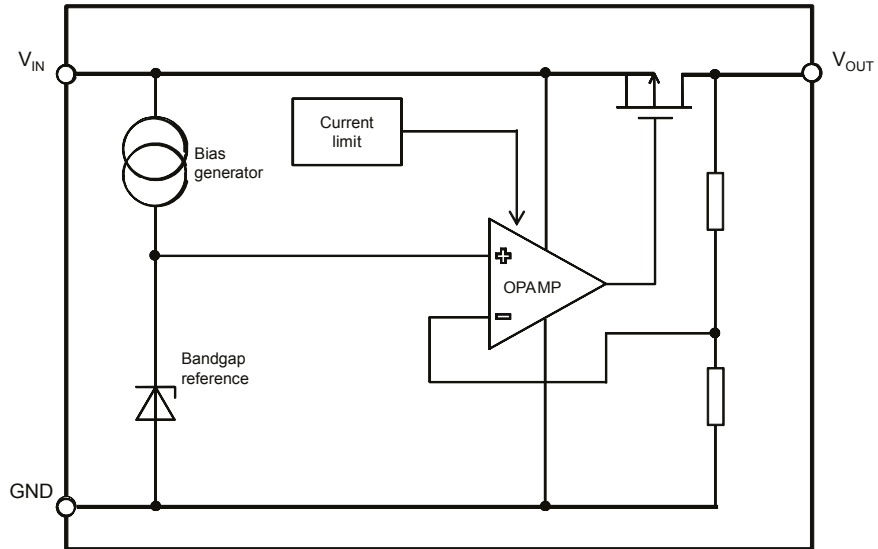

## 2 Pin configuration

Figure 2. Pin connection

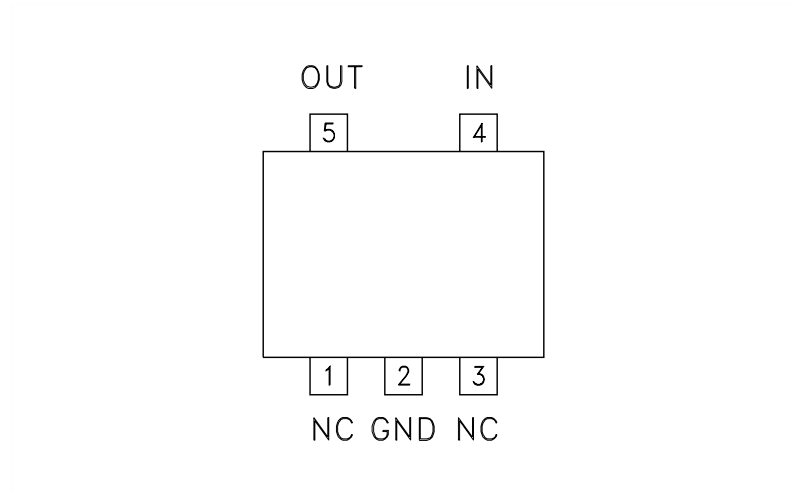

Table 1. Pin description (SOT323-5L)

Symbol	Pin for fixed	Function
IN	4	Input voltage
NC	1,3	Not internally connected
GND	2	Common ground
OUT	5	Output voltage

### 3 Maximum ratings

**Table 2. Absolute maximum ratings**

Symbol	Parameter	Value	Unit
$V_{IN}$	DC input voltage	-0.3 to 26	V
$V_{OUT}$	DC output voltage	-0.3 to $V_{IN} + 0.3$	V
$I_{OUT}$	Continuous output current	According to package power dissipation	A
$P_D^{(1)}$	Maximum power dissipation, SOT323-5L packages	0.45	W
$T_{STG}$	Storage temperature range	-65 to 170	°C
$T_{OP}$	Operating junction temperature range	-40 to 170	°C

1.  $P_D$  is based on an operating temperature of 25 °C or less. It must be derated according to the operating temperature.

**Note:** *Absolute maximum ratings are those values beyond which damage to the device may occur. Functional operation under these conditions is not implied.*

**Table 3. Thermal data**

Symbol	Parameter	Value	Unit
$R_{thJA}$	Thermal resistance junction-ambient	245	°C/W

## 4 Electrical characteristics

$T_J = 25\text{ }^\circ\text{C}$ ,  $V_{IN} = V_{OUT(NOM)} + 1\text{ V}$ ,  $C_{IN} = 0.1\text{ }\mu\text{F}$ ,  $C_{OUT} = 1\text{ }\mu\text{F}$ ,  $I_{OUT} = 1\text{ mA}$ ,  $V_{OUT} = 3.3\text{ V}$  unless otherwise specified.

**Table 4. Electrical characteristics - fixed version**

Symbol	Parameter	Test conditions	Min.	Typ.	Max.	Unit
$V_{IN}$	Operating input voltage	$I_{OUT} = 25\text{ mA}$ , $T_J = -40\text{ }^\circ\text{C}$ to $150\text{ }^\circ\text{C}$	$V_{OUT} + V_{DROP}$		24	V
$I_{OUT}$	Output current	$V_{IN} = 4.3$ to $24\text{ V}$ , $T_J = -40\text{ }^\circ\text{C}$ to $150\text{ }^\circ\text{C}$	0		25	mA
$V_{OUT}$	$V_{OUT}$ total accuracy	$V_{IN} = V_{OUT} + 1$ to $24\text{ V}$ , $I_{OUT} = 0$ to $25\text{ mA}$ , $T_J = -40\text{ }^\circ\text{C}$ to $150\text{ }^\circ\text{C}$	-5		+5	%
$\Delta V_{OUT}$	Line regulation	$V_{IN} = 4.3$ to $24\text{ V}$ , $I_{OUT} = 1\text{ mA}$ , $T_J = -40\text{ }^\circ\text{C}$ to $150\text{ }^\circ\text{C}$		0.001	0.004	%/V
$\Delta V_{OUT}$	Load regulation	$I_{OUT} = 100\text{ }\mu\text{A}$ to $25\text{ mA}$ , $T_J = -40\text{ }^\circ\text{C}$ to $150\text{ }^\circ\text{C}$		0.002	0.003	%/mA
$V_{DROP}$	Dropout voltage	$I_{OUT} = 25\text{ mA}$ , $T_J = -40\text{ }^\circ\text{C}$ to $150\text{ }^\circ\text{C}$		500	1000	mV
$e_N$	Output noise voltage	200 Hz to 100 kHz, $I_{OUT} = 10\text{ mA}$ , $C_{OUT} = 10\text{ }\mu\text{F}$ , $T_J = -40\text{ }^\circ\text{C}$ to $150\text{ }^\circ\text{C}$			210	$\mu\text{V}_{RMS}$
SVR	Supply voltage rejection	$V_{IN} = V_{OUTNOM} + 1\text{ V} \pm V_{RIPPLE}$ , $V_{RIPPLE} = 0.2\text{ V}$ , $I_{OUT} = 1\text{ mA}$ , $C_{OUT} = 10\text{ }\mu\text{F}$	$f = 1\text{ kHz}$	38		dB
		$T_J = -40\text{ }^\circ\text{C}$ to $125\text{ }^\circ\text{C}$	$f = 100\text{ kHz}$	57		
$I_Q$	Quiescent current	$I_{OUT} = 0\text{ mA}$ to $25\text{ mA}$ , $T_J = -40\text{ }^\circ\text{C}$ to $125\text{ }^\circ\text{C}$		3.75	5.5	$\mu\text{A}$
			$V_{IN} = 24\text{ V}$	4.15	6.5	
$T_{ON}$	Turn-on time <sup>(1)</sup>	$V_{IN} = 4.2\text{ V}$ , $C_{OUT} = 10\text{ }\mu\text{F}$ , $I_{OUT} = 25\text{ mA}$ , $T_J = -40\text{ }^\circ\text{C}$ to $150\text{ }^\circ\text{C}$		0.7		ms
$C_{OUT}$	Output capacitor	Capacitance $f = 100\text{ kHz}$	0.47			$\mu\text{F}$

1. Turn-on time is time measured between the input, just exceeding 90% of its final value, and the output voltage, just reaching 95% of its nominal value.

## 5 Application information

### 5.1 External capacitor requirements

A 0.1  $\mu\text{F}$  or a larger input bypass capacitor, connected between IN and GND and located close to the device, is recommended. In this manner, the transient response and noise rejection of the power supply, as a whole, improve. A higher value of the input capacitor may be necessary if large, fast-rise-time load transients are present in the application and if the device is several inches away from the power source.

The ST716 requires an output capacitor connected between OUT and GND to stabilize the internal control loop. Any capacitor (including ceramic and tantalum) with a value higher than 0.47  $\mu\text{F}$ , stabilizes this loop.

### 5.2 Power dissipation and junction temperature

For a reliable operation, junction temperature must not exceed 170 °C. This limits the power dissipation the regulator can handle in any application. To guarantee that the junction temperature is within acceptable limits, calculate the maximum allowable dissipation,  $P_{D(max)}$ , and the dissipation,  $P_D$ , which must be less than or equal to  $P_{D(max)}$ .

The device does not shut down when we exceed the maximum power that the package can handle. Junction temperature must be kept below 170 °C using the above formulas.

The maximum power dissipation limit is given by the following equation:

#### Equation 1

$$P_{D(max)} = (T_{JMAX} - T_A) / R_{thJA}$$

where:

$T_{JMAX}$  is the maximum allowable junction temperature

$R_{thJA}$  is the thermal resistance junction-to-ambient for the package,  $T_A$  is the ambient temperature

The regulator dissipation is calculated by the following equation:

#### Equation 2

$$P_D = (V_{IN} - V_{OUT}) \times I_{OUT}$$

Power dissipation coming from quiescent current is negligible.

The ST716 features the internal current limit. During normal operation, it limits the output current to approximately 350 mA. When the current limit engages, the output voltage scales back linearly until the overcurrent condition ends. Do not exceed the power dissipation ratings of the package.

The device does not shut down when we exceed the maximum power that the package can handle. Junction temperature must be kept below 170 °C using the above formulas.

## 6 Typical application

Figure 3. Application circuit, fixed version

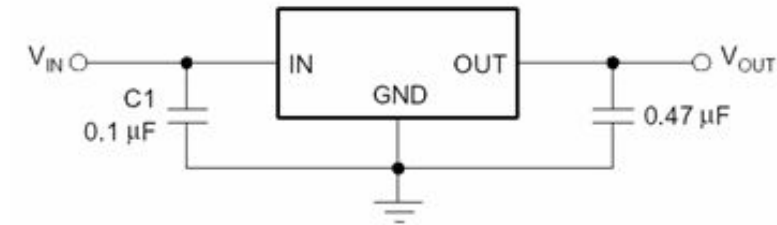

---

## 7 Package information

---

In order to meet environmental requirements, ST offers these devices in different grades of **ECOPACK** packages, depending on their level of environmental compliance. ECOPACK specifications, grade definitions and product status are available at: [www.st.com](http://www.st.com). ECOPACK is an ST trademark.



7.1 SOT323-5L package information

Figure 4. SOT323-5L package outline

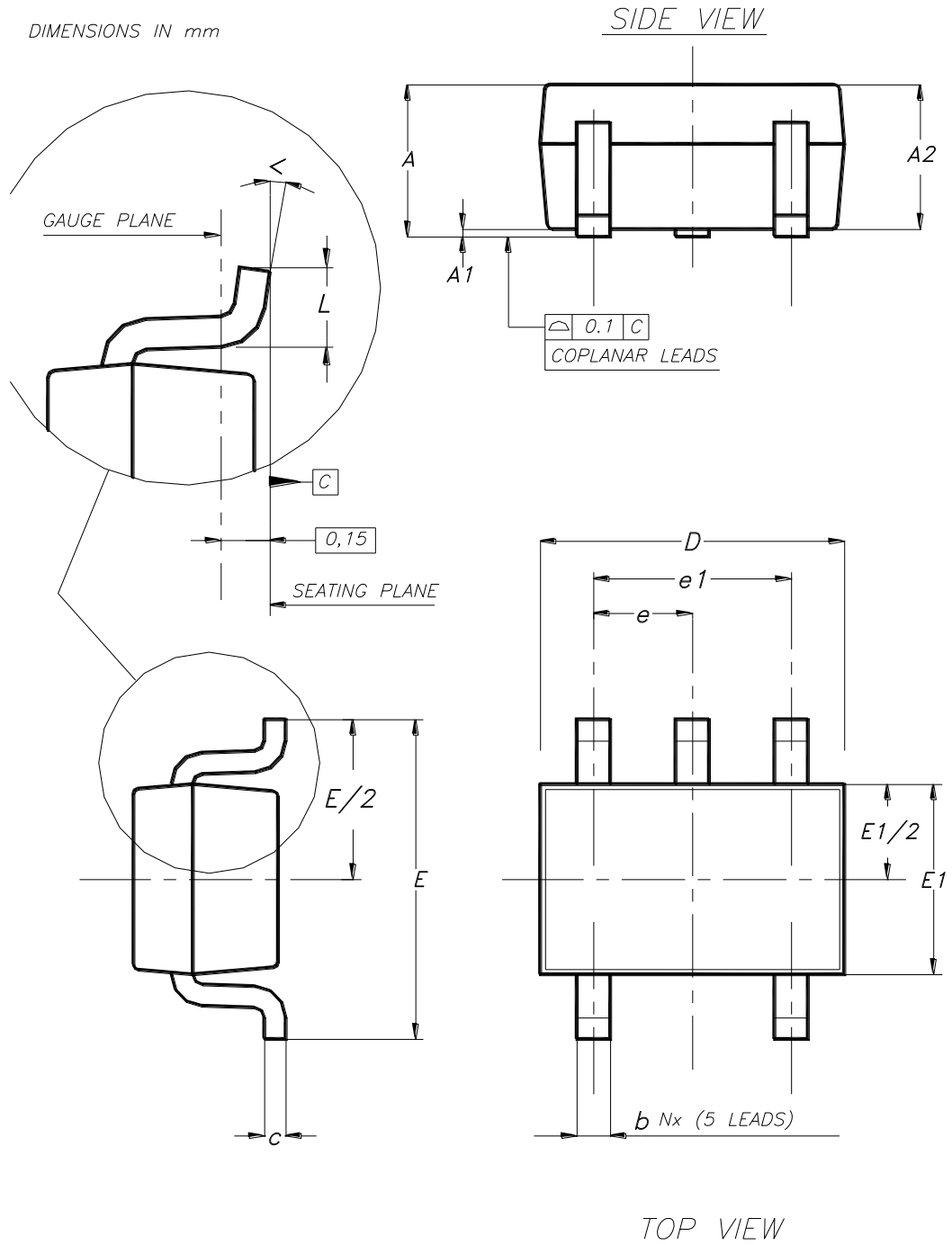

7091413\_f

**Table 5. SOT323-5L package mechanical data**

Dimension	mm		
	Min.	Typ.	Max.
A	0.80		1.10
A1	0		0.10
A2	0.80	0.90	1
b	0.15		0.30
c	0.10		0.22
D	1.80	2	2.20
E	180	2.10	2.40
E1	1.15	1.25	1.35
e		0.65	
e1		1.30	
L	0.26	0.36	0.46
<	0°		8°

## 8 Ordering information

Table 6. Order codes

Order code	Package	Output voltage	Marking
ST716C33R	SOT323-5L	3.3V	633

## Revision history

**Table 7. Document revision history**

Date	Version	Changes
12-Apr-2023	1	Initial release.
18-Dec-2023	2	Added <a href="#">Section 8 Ordering information</a>

## Contents

<b>1</b>	<b>Schematic diagram</b> .....	<b>2</b>
<b>2</b>	<b>Pin configuration</b> .....	<b>3</b>
<b>3</b>	<b>Maximum ratings</b> .....	<b>4</b>
<b>4</b>	<b>Electrical characteristics</b> .....	<b>5</b>
<b>5</b>	<b>Application information</b> .....	<b>6</b>
<b>5.1</b>	External capacitor requirements .....	6
<b>5.2</b>	Power dissipation and junction temperature .....	6
<b>6</b>	<b>Typical application</b> .....	<b>7</b>
<b>7</b>	<b>Package information</b> .....	<b>8</b>
<b>7.1</b>	SOT323-5L package information .....	9
<b>8</b>	<b>Ordering information</b> .....	<b>11</b>
	<b>Revision history</b> .....	<b>12</b>

## List of tables

<b>Table 1.</b>	Pin description (SOT323-5L) . . . . .	3
<b>Table 2.</b>	Absolute maximum ratings . . . . .	4
<b>Table 3.</b>	Thermal data . . . . .	4
<b>Table 4.</b>	Electrical characteristics - fixed version . . . . .	5
<b>Table 5.</b>	SOT323-5L package mechanical data . . . . .	10
<b>Table 6.</b>	Order codes . . . . .	11
<b>Table 7.</b>	Document revision history . . . . .	12

## List of figures

<b>Figure 1.</b>	Block diagram - fixed version . . . . .	2
<b>Figure 2.</b>	Pin connection . . . . .	3
<b>Figure 3.</b>	Application circuit, fixed version . . . . .	7
<b>Figure 4.</b>	SOT323-5L package outline . . . . .	9

**IMPORTANT NOTICE – PLEASE READ CAREFULLY**

STMicroelectronics NV and its subsidiaries (“ST”) reserve the right to make changes, corrections, enhancements, modifications, and improvements to ST products and/or to this document at any time without notice. Purchasers should obtain the latest relevant information on ST products before placing orders. ST products are sold pursuant to ST’s terms and conditions of sale in place at the time of order acknowledgement.

Purchasers are solely responsible for the choice, selection, and use of ST products and ST assumes no liability for application assistance or the design of Purchasers’ products.

No license, express or implied, to any intellectual property right is granted by ST herein.

Resale of ST products with provisions different from the information set forth herein shall void any warranty granted by ST for such product.

ST and the ST logo are trademarks of ST. For additional information about ST trademarks, please refer to [www.st.com/trademarks](http://www.st.com/trademarks). All other product or service names are the property of their respective owners.

Information in this document supersedes and replaces information previously supplied in any prior versions of this document.

© 2021 STMicroelectronics – All rights reserved