



BlueW-2310 Slim Dongle  
STA-UI-A005G  
WiFi & Bluetooth v2.1+EDR  
Datasheets  
Version 1.1



# CONTENT

1	Introductions .....	3
1.1	Features and Benefits .....	3
1.2	Module System Diagram .....	4
1.3	Product Specifications .....	6
1.4	Chipset Information .....	7
2	BlueW-2310 Module Specification.....	8
2.1	Pin Out .....	8
2.2	USB Interface Specification .....	9
2.3	RF Specification.....	11
2.4	Module Power Consumption .....	12
2.5	Module Dimension.....	13



# 1 Introductions

The SYNTEK **STK9120+STK9230 BlueW-2310 module** product provides the highest level of integration and most aggressive BOM cost by integrating IEEE 802.11b/g and Bluetooth 2.1 + EDR into a single MAC/Baseband chip utilizing a single 2.4GHz transceiver. Integrated on-chip power amplifier and LNA reduce external component count, while still able to deliver ample transmit power for most applications.

Different from any other wireless LAN and Bluetooth chip set vendor, SYNTEK uses its patented Software Radio technology to implement both wireless LAN and Bluetooth in software. The highly optimized software radio DSP technology enables **BlueW-2310 module** to integrate class 1 Bluetooth 2.1 + EDR function without any added cost to the total solution. No extra antenna, PA, RF transceiver, resistor, capacitor, crystal or any components are needed. The software solution even guarantees the Bluetooth RF performance if the wireless LAN performance is tested to be good. It eliminates the need for system manufacturers to separately test the module's Bluetooth RF performance, therefore reduce the testing time and cost.

The **BlueW-2310 module** utilizes SYNTEK's patent pending technologies to fundamentally solve the interference and performance issues existed during 802.11b/g and Bluetooth coexistence, thus improving both 802.11b/g and Bluetooth performance and link stability in real environment. As a result, it enhances user experience in a totally wireless environment, where all devices are connected wirelessly through either Bluetooth link or 802.11b/g link.

The single installation package allows for easy setup and configuration of both 802.11b/g and Bluetooth devices. Combined user interface is intuitive to use. Once configured, both wireless links operate transparently in the background.

## 1.1 Features and Benefits

### [Wireless LAN Key Features]

- Single-band 2.4-GHz 802.11g/b with Bluetooth 2.1 + EDR
- Integrated on-chip PA capable of delivering 20dBm output power
- Low active transmit and receive power dissipation and ultra-low power in stand-by and idle modes
- Security:
  - WPA and WPA2 for advanced authentication and encryption
  - AES and TKIP in hardware for reduced power dissipation and encryption



speed

- Worldwide regulatory support
- Patent pending technology maximizes multimedia streaming performance over Bluetooth over WLAN in coexistence mode
- Patent pending Software Radio technology allows single radio, single baseband integration of multiple standards

#### **[Bluetooth Key Features]**

- Bluetooth 2.1 + EDR compliant
- Supports extended synchronous connections (eSCO) for enhanced voice quality
- Supports adaptive frequency hopping (AFH) to reduce radio interference
- Patent pending technology utilizes single transceiver for both WLAN and Bluetooth application to reduce interference and cost

#### **[General Features]**

- Single installation package for both WLAN and Bluetooth device setup
- Single user interface for both WLAN and Bluetooth device configuration and operation
- Patented technology for Bluetooth and Wireless LAN coexistence
- Programmable DSP based solution easily upgradeable to future standards as well as supporting additional wireless technologies such as FM radio or GPS

## **1.2 Module System Diagram**

The **BlueW-2310 module** has 4 main IC components. The RF chip is a high performance zero-IF transceiver with integrated power amplifier. The STK9120 chip implements all wireless LAN and Bluetooth baseband functions in DSP software. It also provides direct interface USB interface. The EEPROM provides the ID for the MAC layer and USB configuration information. The power regulator chip generates the different supply voltages required for this system.

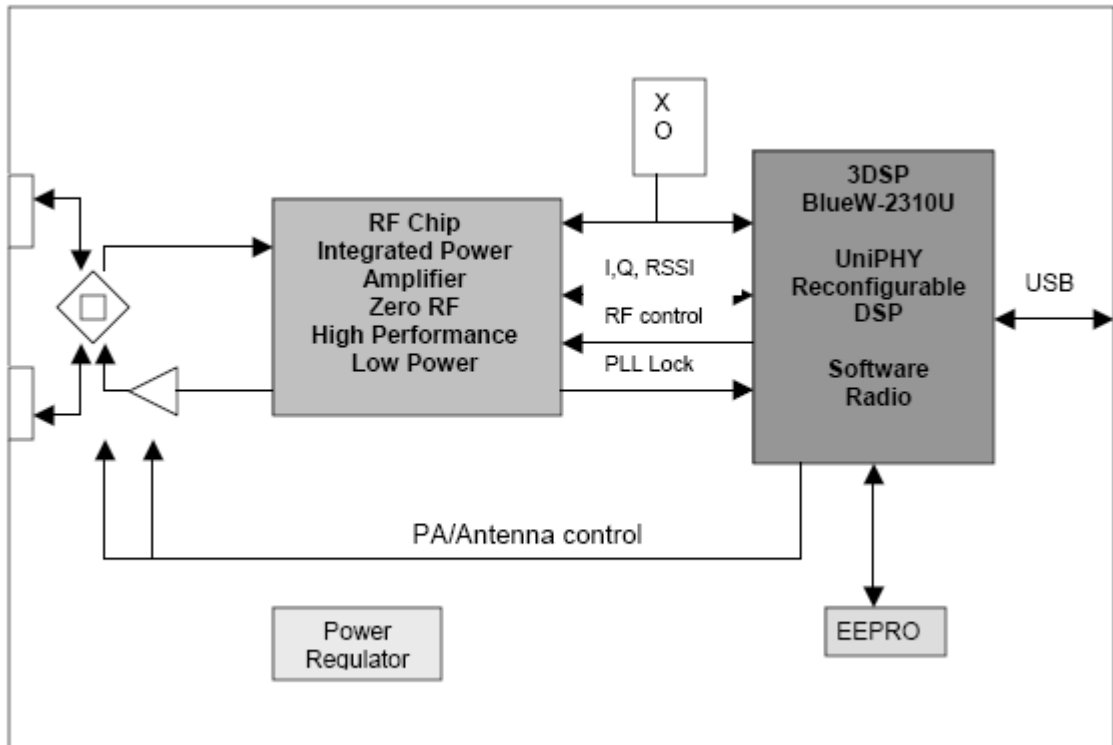



## 1.3 Product Specifications

### Wireless LAN

- Supports 802.11b/g
- Data rate 54, 48, 36, 24, 18, 11, 9, 6, 5.5, 2 , 1Mbps
- Supports data encryption for WEP, TKIP, AES
- Advanced network security features include WPA, WPA2, 802.11i and 802.11x
- Long and short preamble supported
- Class 1 with 18dbm PA, 300m range
- Serial Port Profile
- Dial Up Networking Profile
- File Transfer Profile
- Human Interface Device Profile
- Headset Profile
- Advanced Audio Distribution Profile
- Object Push Profile
- Synchronization Profile
- LAN Access profile
- Personal Area network Profile
- Fax Profile
- Basic Imaging Profile

### Wireless LAN and Bluetooth Logo Certification

- WiFi Enterprise Logo Certified
- Bluetooth 2.1 + EDR Certified
- Microsoft Windows WHQL Certified

### OEM Delivery Package

#### Hardware Reference Design Kit

- Reference Board
- Schematic, Layout, Gerber
- Board performance testing software

#### Software Kit

- 802.11b/g and Bluetooth driver
- User interface software for device configuration and monitoring
- WPA/WPA2 supplicant software
- Complete installation package Production Support Kit
- Board performance testing software
- API document for production software development
- Sample production software based on IQView testing system



## 1.4 Chipset Information

<b>STK9230-AQFG</b>	IEEE 802.11 b/g 2.4GHz Radio Transceiver (integrated PA)
Package	QFN 48pin 7*7 mm

<b>STK9120</b>	DSP base 802.11 b/g and Bluetooth v2.1 + EDR for Baseband and MAC
Package	QFN-76 pin 9*9 mm



## 2 BlueW-2310 Module Specification

### 2.1 Pin Out

Pin No.	Signal Name	Description
5	CB_VCC	3.3V/5V Power supply
4	DM	USB Data +
3	DP	USB Data -
2	GND	Ground
1	Hot_key	Hot_Key Signal





## 2.2 USB Interface Specification

The **BlueW-2310 USB miniCard** module meets USB Specification 2.0 requirements for a high-speed, high-power bus-powered device. The following tables contain relevant Electrical Characteristics for this type of devices referring to the document of *Universal Serial Bus Specification Revision 2.0*.

**Table 2-1 DC Electrical Characteristics**

Parameter	Symbol	Min	Max	Units
<b>Supply Voltage:</b>				
High-power Port	CB_VCC	3.0	5.5	V
<b>Input Levels for High-speed:</b>				
High-speed squelch detection threshold (differential signal amplitude)	VHSSQ	100	150	mV
High speed disconnect detection threshold (differential signal amplitude)	VHSDSC	525	625	mV
High-speed data signaling common mode voltage range(guideline for receiver)	VHSCM	-50	500	mV
<b>Output Levels for High-speed:</b>				
High-speed idle level	VHSOI	-10.0	10.0	mV
High-speed data signaling high	VHSOH	360	440	mV
High-speed data signaling low	VHSOL	-10.0	10.0	mV
Chirp J level (differential voltage)	VCHIRPJ	700	1100	mV
Chirp K level (differential voltage)	VCHIRPK	-900	-500	mV
<b>Decoupling Capacitance:</b>				
Upstream Facing Port Bypass Capacitance	CRPB	1.0	10.0	μF
<b>Terminations:</b>				
Bus Pull-up Resistor on Upstream Facing Port	RPU	1.425	1.575	kΩ
Termination voltage for upstream facing port pull-up (RPU)	VTERM	3.0	3.6	V
<b>Termination in High-speed:</b>				
Termination Voltage in high-speed	VHSTERM	-10	10	mV



**Table 2-2 High-speed Source Electrical Characteristics**

Parameter	Symbol	Min	Max	Units
<b>Driver Characteristics:</b>				
Rise Time (10% - 90%)	THSR	500		ps
Fall Time (10% - 90%)	THSF	500		ps
Driver Output Resistance (which also serves as high-speed termination)	ZHSDRV	40.5	49.5	$\Omega$
<b>Clock Timings:</b>				
High-speed Data Rate	THSDRAT	479.760	480.240	Mb/s
Microframe Interval	THSFRAM	124.9375	125.0625	$\mu$ s
Consecutive Microframe Interval Difference	THSRFI		4	bits

Note 1: The maximum load specification is the maximum effective capacitive load allowed that meets the target VBUS drop of 330 mV.



## 2.3 RF Specification

Table 2-3 WLAN Receiver RF Specification

Throughput	Condition	MIN	NOM	MAX	Unit
<b>802.11b</b>					
1Mbps	PER < 8%, Packet Size = 1024 bytes		-93	-80	dBm
2Mbps			-91	-80	dBm
5.5Mbps			-87	-76	dBm
11Mbps			-86	-76	dBm
<b>802.11g</b>					
6Mbps	PER < 10%, Packet Size = 1024 bytes		-85	-80	dBm
9Mbps			-85	-80	dBm
12Mbps			-84	-80	dBm
18Mbps			-83	-80	dBm
24Mbps			-80	-75	dBm
36Mbps			-78	-75	dBm
48Mbps			-75	-70	dBm
54Mbps			-71	-70	dBm

Table 2-4 WLAN Transmitter RF Specification

Throughput	Condition	MIN	NOM	MAX	Unit
<b>802.11b</b>					
Output Power@1Mbps	As specified in IEEE 802.11		18		dBm
Output Power@2Mbps			18		dBm
Output Power@5.5Mbps			18		dBm
Output Power@11Mbps			18		dBm
<b>802.11g</b>					
Output Power@6Mbps	PER < 10%, Packet Size = 1024 bytes		18		dBm
Output Power@9Mbps			18		dBm
Output Power@12Mbps			18		dBm
Output Power@18Mbps			18		dBm
Output Power@24Mbps			17		dBm
Output Power@36Mbps			16		dBm
Output Power@48Mbps			16		dBm



Output Power@54Mbps			15		dBm
---------------------	--	--	----	--	-----

**Table 2-5 Bluetooth RF Specification**

Parameter	Condition	MIN	NOM	MAX	Unit
Output Power	Class 2	-6		4	dBm
Frequency Range		2400		2483.5	MHz
Sensitivity GFSK, BER<=0.1%				-75	dBm
EDR Relative Power		-4		1	dB
EDR Sensitivity n/4 QPSK, BER<=0.01%				-75	dBm
EDR Sensitivity 8DPSK, BER<=0.01%				-75	dBm

## 2.4 Module Power Consumption

Parameter	MIN	NOM	MAX	Unit
Power Consumption		800		mW
Operating current CB_VCC=5V	120	160	280	mA
Operating current CB_VCC=3V	190	230	420	mA
Standby current (USB connected)	30		50	mA



## 2.5 Module Dimension

