

2.1-channel high-efficiency digital audio system

Features

- Wide supply voltage range
 - 4.5 V to 21.5 V operating
 - 24 V absolute maximum rating
- Three power-output configurations
 - 2-channel ternary PWM (stereo mode) (2 x 20 W into 8 Ω at 18 V)
 - 3-channel (left, right using binary and LFE) ternary PWM (2.1 mode) (2 x 9 W + 1 x 20 W into 2 x 4 Ω, 1 x 8 Ω at 18 V)
 - 2-channel ternary PWM (2 x 20 W) + stereo lineout ternary
- 2.1 channels of 24-bit DDX[®]
- 100 dB SNR and dynamic range
- Selectable 32 kHz to 192 kHz input sample rates
- I²C control with selectable device address
- Digital gain/attenuation +48 dB to -80 dB in 0.5 dB steps
- Software volume update
- Individual channel and master gain/attenuation
- Dual independent limiters/compressors
- Dynamic range compression or anti-clipping modes
- Automodes
 - 15 preset cross-over filters
 - 5 preset anti-clipping modes
 - Preset night-time listening mode
- Individual channel and master software and hardware mute
- Independent channel volume and DSP bypass
- Automatic zero-detect mute
- Automatic invalid input detect mute

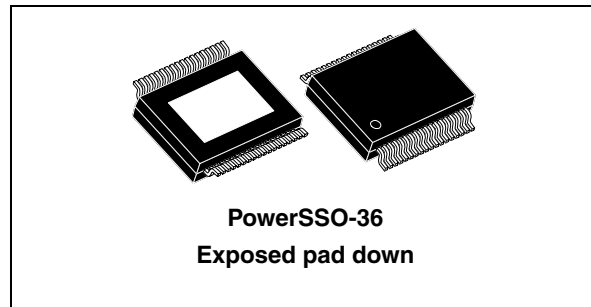

- 2-channel I²S input data interface
- Input and output channel mapping
- 4 x 28-bit user programmable biquads (EQ) per channel
- Up to 3 different EQ coefficients settings can be stored and selected using I²C interface
- Bass/treble tone control
- DC-blocking selectable high-pass filter
- Selectable de-emphasis
- Sub channel mix into left and right channels
- Advanced AM interference frequency switching and noise-suppression modes
- Selectable high or low-bandwidth noise-shaping topologies
- Variable max power correction for lower full-power THD
- Selectable clock input ratio
- 96 kHz internal processing sample rate, 24 to 28-bit precision
- Thermal overload and short-circuit protection embedded
- Video application: 576 x fs input mode supported
- PowerSSO-36 exposed pad down package

Figure 1. Device summary

Order code	Package	Packaging
STA335BWS	PowerSSO-36 exposed pad down	Tube
STA335BWS13TR	PowerSSO-36 exposed pad down	Tape and reel

Contents

www.datasheet4u.com

- 1 Description and block diagram 9**
 - 1.1 Description 9
 - 1.2 Block diagram 10
- 2 Connection diagram and pin description 11**
 - 2.1 Connection diagram 11
 - 2.2 Pin description 11
 - 2.3 Thermal data 13
- 3 Electrical specifications 14**
 - 3.1 Absolute maximum ratings 14
 - 3.2 Recommended operating condition 14
 - 3.3 Electrical specifications - digital section 15
 - 3.4 Electrical specifications - power section 15
 - 3.5 Power-on sequence 17
 - 3.6 Testing 17
 - 3.6.1 Functional pin status 17
- 4 Processing data paths 19**
- 5 I²C bus specification 20**
 - 5.1 Communication protocol 20
 - 5.1.1 Data transition or change 20
 - 5.1.2 Start condition 20
 - 5.1.3 Stop condition 20
 - 5.1.4 Data input 20
 - 5.2 Device addressing 20
 - 5.3 Write operation 21
 - 5.3.1 Byte write 21
 - 5.3.2 Multi-byte write 21
 - 5.4 Read operation 21
 - 5.4.1 Current address byte read 21
 - 5.4.2 Current address multi-byte read 21



www.datasheet4u.com

5.4.3 Random address byte read 21
 5.4.4 Random address multi-byte read 21
 5.4.5 Write mode sequence 22
 5.4.6 Read mode sequence 22

6 Register description 23

6.1 Configuration register A (addr 0x00) 25
 6.1.1 Master clock select 25
 6.1.2 Interpolation ratio select 26
 6.1.3 Thermal warning recovery bypass 26
 6.1.4 Thermal warning adjustment bypass 27
 6.1.5 Fault detect recovery bypass 27
 6.2 Configuration register B (addr 0x01) 27
 6.2.1 Serial audio input interface format 27
 6.2.2 Serial data interface 28
 6.2.3 Serial data first bit 28
 6.2.4 Delay serial clock enable 29
 6.2.5 Channel input mapping 30
 6.3 Configuration register C (addr 0x02) 30
 6.3.1 DDX power output mode 30
 6.3.2 DDX compensating pulse size register 31
 6.3.3 Over-current warning detect adjustment bypass 31
 6.4 Configuration register D (addr 0x03) 31
 6.4.1 High-pass filter bypass 31
 6.4.2 De-emphasis 32
 6.4.3 DSP bypass 32
 6.4.4 Post-scale link 32
 6.4.5 Biquad coefficient link 32
 6.4.6 Dynamic range compression/anti-clipping bit 33
 6.4.7 Zero-detect mute enable 33
 6.4.8 Miami Mode™ enable 33
 6.5 Configuration register E (addr 0x04) 33
 6.5.1 Max power correction variable 33
 6.5.2 Max power correction 34
 6.5.3 Noise-shaper bandwidth selection 34
 6.5.4 AM mode enable 34
 6.5.5 PWM speed mode 34



www.datasheet4u.com

- 6.5.6 Distortion compensation variable enable 34
- 6.5.7 Zero-crossing volume enable 35
- 6.5.8 Soft volume update enable 35
- 6.6 Configuration register F (addr 0x05) 35
 - 6.6.1 Output configuration 35
 - 6.6.2 Invalid input detect mute enable 40
 - 6.6.3 Binary output mode clock loss detection 41
 - 6.6.4 LRCK double trigger protection 41
 - 6.6.5 Auto EAPD on clock loss 41
 - 6.6.6 IC power down 41
 - 6.6.7 External amplifier power down 41
- 6.7 Volume control registers (addr 0x06 to 0x0A) 42
 - 6.7.1 Mute/line output configuration register 42
 - 6.7.2 Master volume register 42
 - 6.7.3 Channel 1 volume 42
 - 6.7.4 Channel 2 volume 42
 - 6.7.5 Channel 3 and line-output volume 43
- 6.8 Auto mode registers (addr 0x0B and 0x0C) 44
 - 6.8.1 Automode register 1 (address 0x0B) 44
 - 6.8.2 AutoMode register 2 (address 0x0C) 44
 - 6.8.3 AM interference frequency switching 45
 - 6.8.4 Bass management crossover 45
- 6.9 Channel configuration registers (addr 0x0E to 0x10) 46
 - 6.9.1 Tone control bypass 46
 - 6.9.2 EQ bypass 46
 - 6.9.3 Volume bypass 47
 - 6.9.4 Binary output enable registers 47
 - 6.9.5 Limiter select 47
 - 6.9.6 Output mapping 47
- 6.10 Tone control register (addr 0x11) 48
 - 6.10.1 Tone control 48
- 6.11 Dynamics control registers (addr 0x12 to 0x15) 48
 - 6.11.1 Limiter 1 attack/release rate 48
 - 6.11.2 Limiter 1 attack/release threshold 48
 - 6.11.3 Limiter 2 attack/release rate 48
 - 6.11.4 Limiter 2 attack/release threshold 49

www.datasheet4u.com

6.12	User-defined coefficient control registers (addr 0x16 to 0x26)	52
6.12.1	Coefficient address register	52
6.12.2	Coefficient b1 data register bits 23:16	52
6.12.3	Coefficient b1 data register bits 15:8	53
6.12.4	Coefficient b1 data register bits 7:0	53
6.12.5	Coefficient b2 data register bits 23:16	53
6.12.6	Coefficient b2 data register bits 15:8	53
6.12.7	Coefficient b2 data register bits 7:0	53
6.12.8	Coefficient a1 data register bits 23:16	53
6.12.9	Coefficient a1 data register bits 15:8	53
6.12.10	Coefficient a1 data register bits 7:0	54
6.12.11	Coefficient a2 data register bits 23:16	54
6.12.12	Coefficient a2 data register bits 15:8	54
6.12.13	Coefficient a2 data register bits 7:0	54
6.12.14	Coefficient b0 data register bits 23:16	54
6.12.15	Coefficient b0 data register bits 15:8	54
6.12.16	Coefficient b0 data register bits 7:0	54
6.12.17	Coefficient write/read control register	55
6.12.18	User-defined EQ	57
6.12.19	Pre-scale	57
6.12.20	Post-scale	57
6.12.21	Over-current post-scale	58
6.13	Variable max power correction registers (addr 0x27 to 0x28)	59
6.14	Variable distortion compensation registers (addr 0x29 to 0x2A)	59
6.15	Fault detect recovery constant registers (addr 0x2B to 0x2C)	60
6.16	Device status register (addr 0x2D)	60
6.17	EQ coefficients and DRC configuration register (addr 0x31)	61
7	Application	62
7.1	Application schematic and power supplies	62
7.2	PLL filter schematic	62
7.3	Typical output configuration	63
8	Package thermal characteristics	64
9	Package information	65



10 Trademarks and other acknowledgements 66

11 Revision history 67

www.datasheet4u.com



List of tables

www.datasheet4u.com

Table 1.	Pin description	11
Table 2.	Thermal data.	13
Table 3.	Absolute maximum ratings	14
Table 4.	Recommended operating condition	14
Table 5.	Electrical specifications - digital section	15
Table 6.	Electrical specifications - power section	15
Table 7.	Power-on sequence	17
Table 8.	Functional pin status.	17
Table 9.	Register summary.	23
Table 10.	Input sampling rates	25
Table 11.	IR bit settings as a function of input sample rate	26
Table 12.	Support serial audio input formats for MSB-first (SAIFB = 0)	28
Table 13.	Supported serial audio input formats for LSB-first (SAIFB = 1)	29
Table 14.	Output modes	30
Table 15.	Compensating pulse size	31
Table 16.	Output configuration engine selection	35
Table 17.	Master volume offset as a function of MV[7:0]	43
Table 18.	Channel volume as a function of CxV[7:0]	43
Table 19.	AutoMode gain compression/limiters selection.	44
Table 20.	AutoMode AM switching frequency selection	45
Table 21.	Bass management crossover frequency	45
Table 22.	Channel limiter mapping as a function of CxLS bits	47
Table 23.	Channel output mapping as a function of CxOM bits	47
Table 24.	Tone control boost/cut as a function of BTC and TTC bits	48
Table 25.	Limiter attack rate as a function of LxA bits	50
Table 26.	Limiter release rate as a function of LxR bits	50
Table 27.	Limiter attack threshold as a function of LxAT bits (AC-mode).	51
Table 28.	Limiter release threshold as a function of LxRT bits (AC-mode)	51
Table 29.	Limiter attack threshold as a function of LxAT bits (DRC-Mode)	52
Table 30.	Limiter release threshold as a as a function of LxRT bits (DRC-Mode)	52
Table 31.	RAM block for biquads, mixing, scaling and bass management.	58
Table 32.	SEL bitfield description	61
Table 33.	AMGC bitfield description	61
Table 34.	AMGC bitfield description	61
Table 35.	Document revision history	67

List of figures

Figure 1.	Device summary	1
Figure 2.	Block diagram	10
Figure 3.	Pin connection PowerSSO-36 (Top view)	11
Figure 4.	Test circuit 1	18
Figure 5.	Test circuit 2	18
Figure 6.	STA335BWS processing data flow	19
Figure 7.	Write mode sequence	22
Figure 8.	Read mode sequence	22
Figure 9.	OCFG = 00 (default value)	36
Figure 10.	OCFG = 01	36
Figure 11.	OCFG = 10	37
Figure 12.	STA335BWS output mapping scheme	37
Figure 13.	2.0 channels (OCFG = 00) PWM slots	38
Figure 14.	2.1 channels (OCFG = 01) PWM slots	39
Figure 15.	2.1 channels (OCFG = 10) PWM slots	40
Figure 16.	Basic limiter and volume flow diagram	50
Figure 17.	Application schematic	62
Figure 18.	PLL application scheme	63
Figure 19.	Output configuration for stereo BTL mode	63
Figure 20.	Triple-layer PCB with copper ground area and 16 via holes	64
Figure 21.	PowerSSO-36 power derating curve	64
Figure 22.	PowerSSO-36 (slug-up) mechanical data and package dimensions	65

1 Description and block diagram

1.1 Description

www.datasheet4u.com

The STA335BWS is an integrated solution of digital audio processing, digital amplifier control, and DDX[®] power-output stage, thereby creating a high-power single-chip DDX[®] solution comprising of high-quality, high-efficiency, all digital amplification.

The STA335BWS is part of the Sound Terminal™ family that provides full digital audio streaming to the speaker offering cost effectiveness, low energy dissipation and sound enrichment.

The STA335BWS power section consists of four independent half-bridges. These can be configured via digital control to operate in different modes. 2.1 channels can be provided by two half-bridges and a single full-bridge, providing up to 2 x 9 W + 1 x 20 W of power output. Two channels can be provided by two full-bridges, providing up to 2 x 20 W of power. The IC can also be configured as a 2.1 channels with 2 x 20 W provided by the device and external power for DDX[®] power drive.

Also provided in the STA335BWS are a full assortment of digital processing features. This includes up to four programmable 28-bit biquads (EQ) per channel, and bass/treble tone control. AutoModes enable a time-to-market advantage by substantially reducing the amount of software development needed for certain functions. This includes auto volume loudness, preset volume curves and preset EQ settings. New advanced AM radio-interference reduction modes. The serial audio data input interface accepts all possible formats, including the popular I²S format. Three channels of DDX[®] processing are provided. This high-quality conversion from PCM audio to DDX patented tri-state PWM switching waveform provides over 100 dB SNR and dynamic range.

1.2 Block diagram

Figure 2. Block diagram

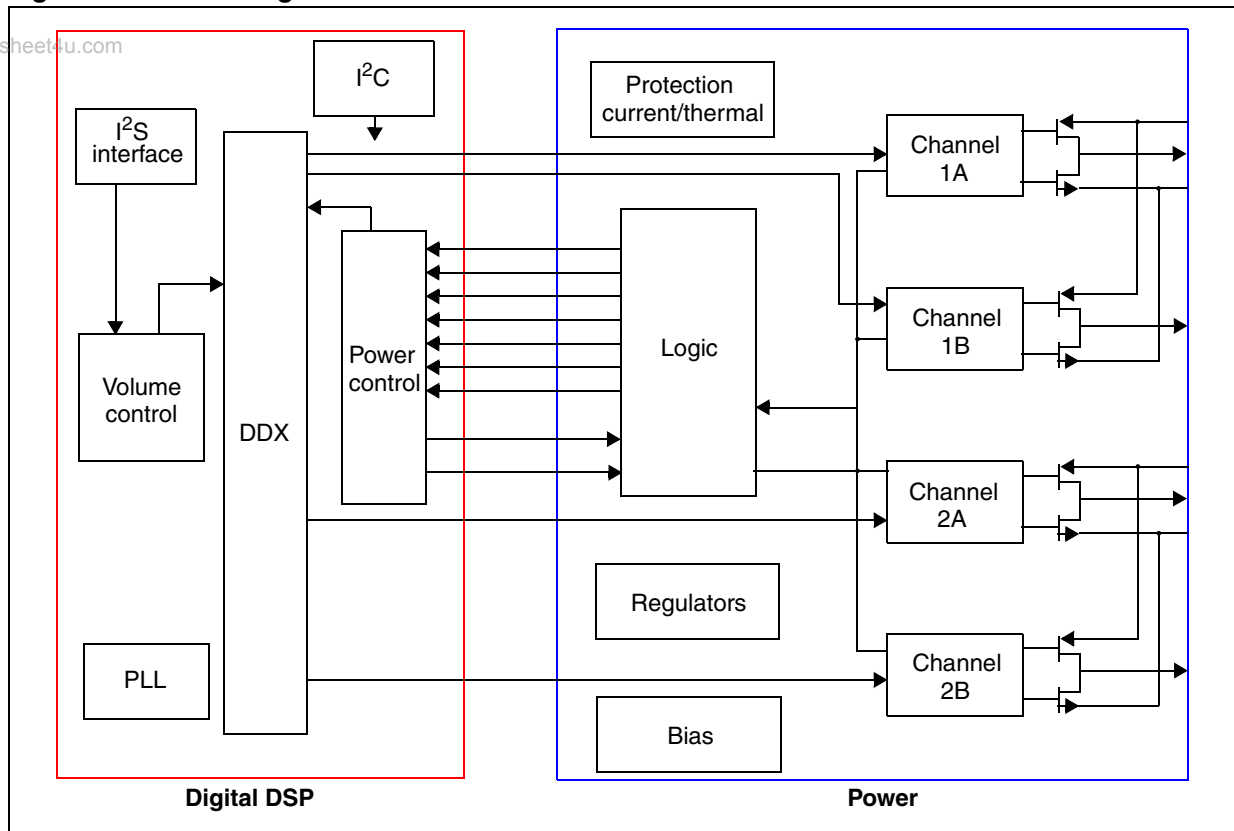

www.datasheet4u.com

2 Connection diagram and pin description

2.1 Connection diagram

www.datasheet4u.com

Figure 3. Pin connection PowerSSO-36 (Top view)

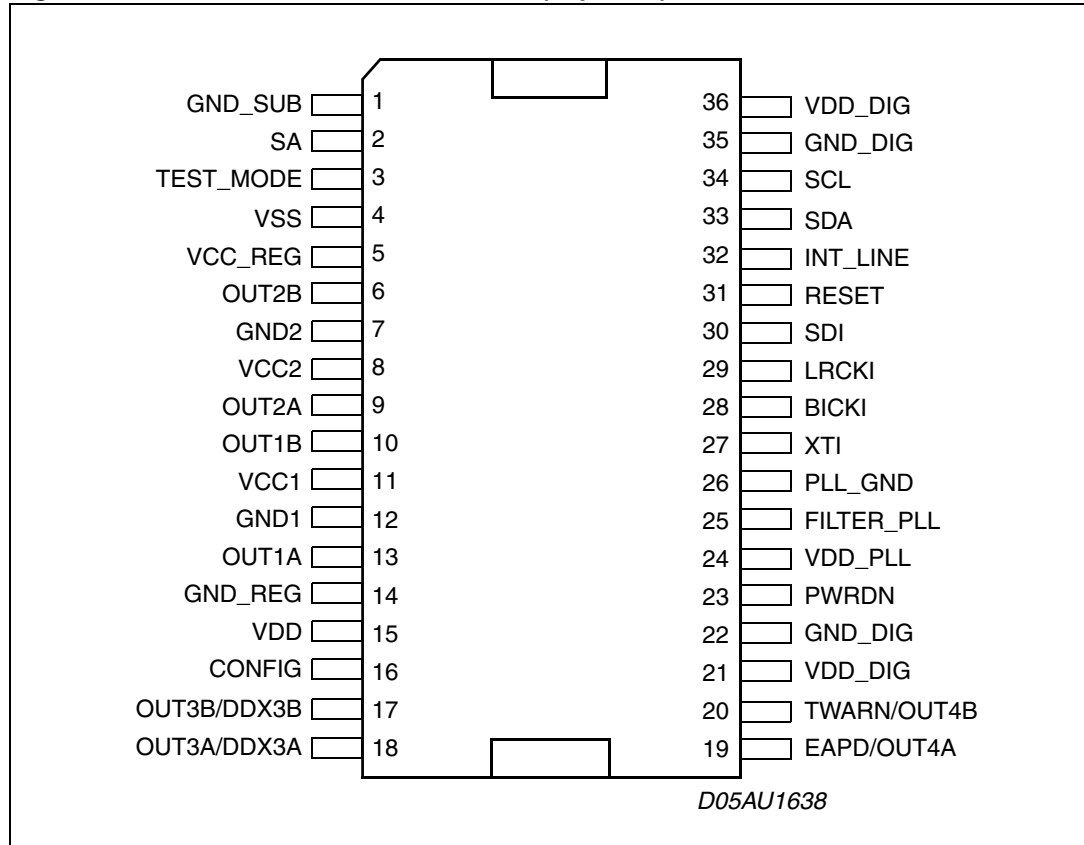

2.2 Pin description

Table 1. Pin description

Pin	Type	Name	Description
1	GND	GND_SUB	Substrate ground
2	I	SA	I ² C select address
3	I	TEST_MODE	This pin must be connected to ground
4	I/O	VSS	Internal reference at Vcc - 3.3 V
5	I/O	Vcc_REG	Internal Vcc reference
6	O	OUT2B	Output half bridge 2B
7	GND	GND2	Power negative supply
8	Power	VCC2	Power positive supply

Table 1. Pin description (continued)

Pin	Type	Name	Description
9	O	OUT2A	Output half bridge 2A
10	O	OUT1B	Output half bridge 1B
11	Power	VCC1	Power positive supply
12	GND	GND1	Power negative supply
13	I/O	OUT1A	Output half bridge 1A
14	GND	GND_REG	Internal ground reference
15	Power	VDD	Internal 3.3 V reference voltage
16	I	CONFIG	Paralleled mode command
17	O	OUT3B/DDX3B	PWM out CH3B - external bridge
18	O	OUT3A/DDX3A	PWM out CH3A - external bridge
19	O	EAPD/OUT4A	Power down for external bridge
20	I	TWARN/OUT4B	Thermal warning from external bridge
21	Power	VDD_DIG	Digital supply voltage
22	GND	GND_DIG	Digital ground
23	I	PWRDN	Power down
24	Power	VDD_PLL	Positive supply for PLL
25	I	FILTER_PLL	Connection to PLL filter
26	GND	GND_PLL	Negative supply for PLL
27	I	XTI	PLL input clock
28	I	BICKI	I ² S serial clock
29	I	LRCKI	I ² S left/right clock
30	I	SDI	I ² S serial data channels 1 and 2
31	I	RESET	Reset
32	O	INT_LINE	Fault interrupt
33	I/O	SDA	I ² C serial data
34	I	SCL	I ² C serial clock
35	GND	GND_DIG	Digital ground
36	Power	VDD_DIG	Digital supply voltage

www.datasheet4u.com

2.3 Thermal data

Table 2. Thermal data

	Parameter	Min	Typ	Max	Unit
$R_{th\ j-case}$	Thermal resistance junction-case (thermal pad)			1.5	°C/W
T_{th-sdj}	Thermal shut-down junction temperature		150		°C
T_{th-w}	Thermal warning temperature		130		°C
T_{th-sdh}	Thermal shut-down hysteresis		20		°C
$R_{th\ j-amb}$	Thermal resistance junction-ambient ⁽¹⁾				

1. See [Section 8: Package thermal characteristics on page 64](#) for details.

3 Electrical specifications

3.1 Absolute maximum ratings

www.datasheet4u.com

Table 3. Absolute maximum ratings

Symbol	Parameter	Min	Typ	Max	Unit
V _{cc}	Power supply voltage (VCCxA, VCCxB)	-0.3		23	V
VDD_DIG	Digital supply voltage	-0.3		4	V
VDD_PLL	PLL supply voltage	-0.3		4	
T _{op}	Operating junction temperature	0		150	°C
T _{stg}	Storage temperature	-40		150	°C

Note: 1 Stresses beyond those listed under “Absolute maximum ratings” make cause permanent damage to the device. These are stress ratings only, and functional operation of the device at these or any other conditions beyond those indicated under “Recommended operating condition” are not implied. Exposure to absolute-maximum-rated conditions for extended periods may affect device reliability. In the real application, power supply with nominal value rated inside recommended operating conditions, may experience some rising beyond the maximum operating condition for short time when no or very low current is sinked (amplifier in mute state). In this case the reliability of the device is guaranteed, provided that the absolute maximum rating is not exceeded.

3.2 Recommended operating condition

Table 4. Recommended operating condition

Symbol	Parameter	Min	Typ	Max	Unit
V _{cc}	Power supply voltage (VCCxA, VCCxB)	4.5		21.5	V
VDD_DIG	Digital supply voltage	2.7	3.3	3.6	V
VDD_PLL	PLL supply voltage	2.7	3.3	3.6	V
T _{amb}	Ambient temperature	-20		70	°C

3.3 Electrical specifications - digital section

Table 5. Electrical specifications - digital section

Symbol	Parameter	Conditions	Min	Typ	Max	Unit
I_{il}	Low level input current without pull device	$V_i = 0\text{ V}$	-10		10	μA
I_{ih}	High level input current without pull device	$V_i = V_{DD_DIG} = 3.6\text{ V}$	-10		10	μA
V_{il}	Low level input voltage				$0.2 \cdot V_{DD_DIG}$	V
V_{ih}	High level input voltage		$0.8 \cdot V_{DD_DIG}$			V
V_{ol}	Low level output voltage	$I_{ol} = 2\text{ mA}$			$0.4 \cdot V_{DD_DIG}$	V
V_{oh}	High level output voltage	$I_{oh} = 2\text{ mA}$	$0.8 \cdot V_{DD_DIG}$			V
I_{pu}	Pull current		-25	66	125	μA
R_{pu}	Equivalent pull resistance			50		$\text{K}\Omega$

3.4 Electrical specifications - power section

The specifications given in this section are with the operating conditions $V_{CC} = 18\text{ V}$, $f = 1\text{ kHz}$, $f_{sw} = 384\text{ kHz}$, $T_{amb} = 25^\circ\text{ C}$, $R_L = 8\ \Omega$, unless otherwise specified.

Table 6. Electrical specifications - power section

Symbol	Parameter	Conditions	Min	Typ	Max	Unit
P_o	Output power BTL	$V_{CC} = 18\text{ V}$	THD = 1%		16	W
			THD = 10%		20	
	Output power SE	$V_{CC} = 18\text{ V}$	THD = 1%		4	W
			THD = 10%		5	
R_{dsON}	Power Pchannel/Nchannel MOSFET (total bridge)	$I_d = 1.5\text{ A}$		180	250	$\text{m}\Omega$
g_P	Power Pchannel RdsON matching	$I_d = 1.5\text{ A}$	95			%
g_N	Power Nchannel RdsON matching	$I_d = 1.5\text{ A}$	95			%
I_{dss}	Power Pchannel/Nchannel leakage I_{dss}	$V_{CC} = 20\text{ V}$			10	μA
g_P	Power Pchannel RdsON Matching	$I_d = 1.5\text{ A}$	95			%
g_N	Power Nchannel RdsON Matching	$I_d = 1.5\text{ A}$	95			%
I_{dss}	Power Pchannel/Nchannel leakage	$V_{CC} = 20\text{ V}$			10	μA
I_{LDT}	Low current dead time (static)	Resistive load ⁽¹⁾		8	15	ns

Table 6. Electrical specifications - power section (continued)

Symbol	Parameter	Conditions	Min	Typ	Max	Unit
I_{HDT}	High current dead time (dynamic)	$I_{load} = 1.5 \text{ A}$ ⁽¹⁾		15	30	ns
t_r	Rise time	Resistive load ⁽¹⁾		10	18	ns
t_f	Fall time	Resistive load ⁽¹⁾		10	18	ns
V_{CC}	Supply voltage operating voltage		4.5		21.5	V
I_{VCC}	Supply current from Vcc in power down	PWRDN = 0		0.1	1	mA
	Supply current from Vcc in operation	PCM Input signal = -60 dBFS Switching frequency = 384 kHz No LC filters		52	60	mA
I_{VDD}	Supply current DDX processing (reference only)	Internal clock = 49.152 MHz		55	70	mA
I_{lim}	Overcurrent limit	⁽²⁾	2.2	3.0	4.0	A
Isc	Short circuit protection	Hi-Z output	2.7	3.6		A
UVL	Under voltage protection			3.5	4.3	V
t_{min}	Output minimum pulse width	No load	20	30	60	ns
DR	Dynamic range			100		dB
SNR	Signal to noise ratio, ternary mode	A-Weighted		100		dB
	Signal to noise ratio binary mode			90		dB
PSSR	Power supply rejection ratio	DDX stereo mode, <5 kHz $V_{RIPPLE} = 1 \text{ V RMS}$ Audio input = dither only		80		dB
THD+N	Total harmonic distortion + noise	DDX stereo mode, $P_o = 1 \text{ W}$ $f = 1 \text{ kHz}$		0.2		%
X_{TALK}	Crosstalk	DDX stereo mode, <5 kHz One channel driven @ 1 W Other channel measured		80		dB
η	Peak efficiency, DDX mode	$P_o = 2 \times 20 \text{ W}$ into 8 Ω		90		%
	Peak efficiency, binary modes	$P_o = 2 \times 9 \text{ W}$ into 4 Ω , 1 x 20 W into 8 Ω		87		

1. Refer to [Figure 4: Test circuit 1](#).
2. Limit current if the register (OCRb par 6.1.3.3) overcurrent warning detect adjustment bypass is enabled. When disabled refer to Isc.

3.5 Power-on sequence

Table 7. Power-on sequence

www.datasheet4u.com

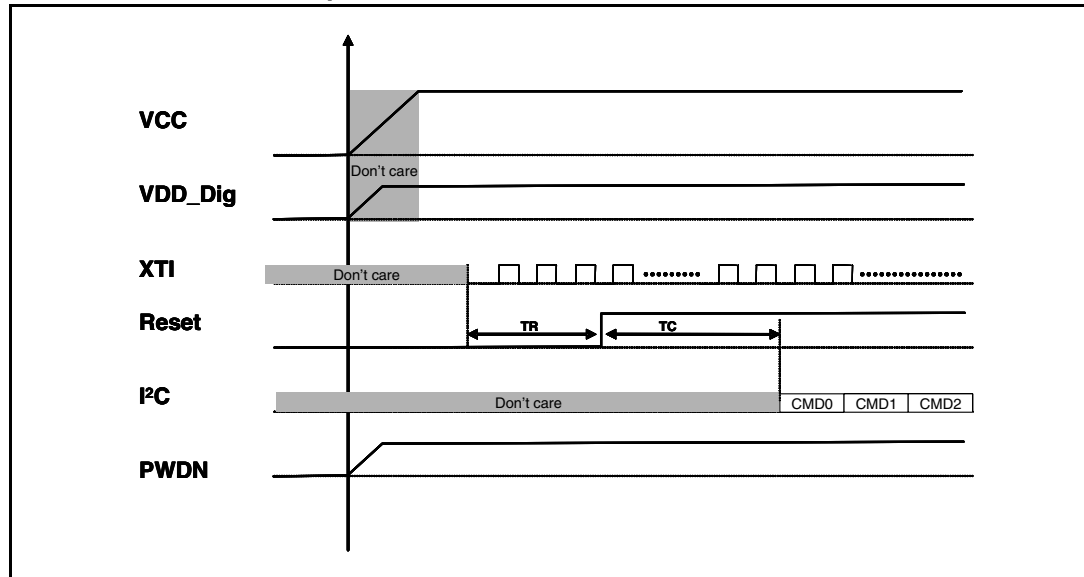

Where:

TR = minimum time between XTI master clock stable and Reset removal: 1 ms

TC = minimum time between Reset removal and I²C program, sequence start: 1msec

Note: Clock stable means: $f_{max} - f_{min} < 1 \text{ MHz}$

Note: No specific VCC and VDD_Dig turn-on sequence is required

3.6 Testing

3.6.1 Functional pin status

Table 8. Functional pin status

Pin name	Pin #	Logic value	IC status
PWRDN	23	0	Low absorption
PWRDN	23	1	Normal operation
TWARN	20	0	From external power stage is indicated a temperature warning
TWARN	20	1	Normal operation
EAPD	19	0	Low absorption for power stage All internal regulators are switched off
EAPD	19	1	Normal operation

Figure 4. Test circuit 1

www.datasheet4u.com

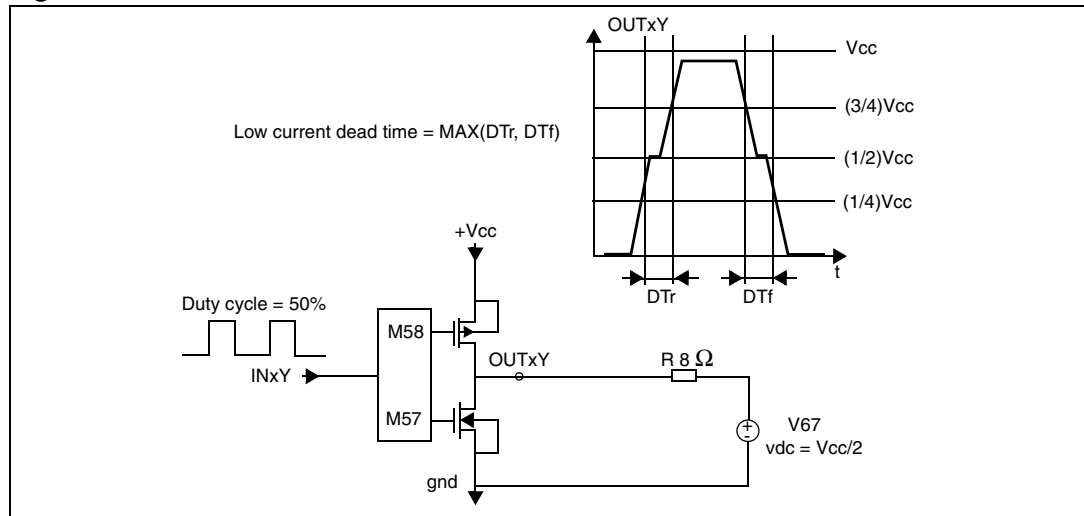
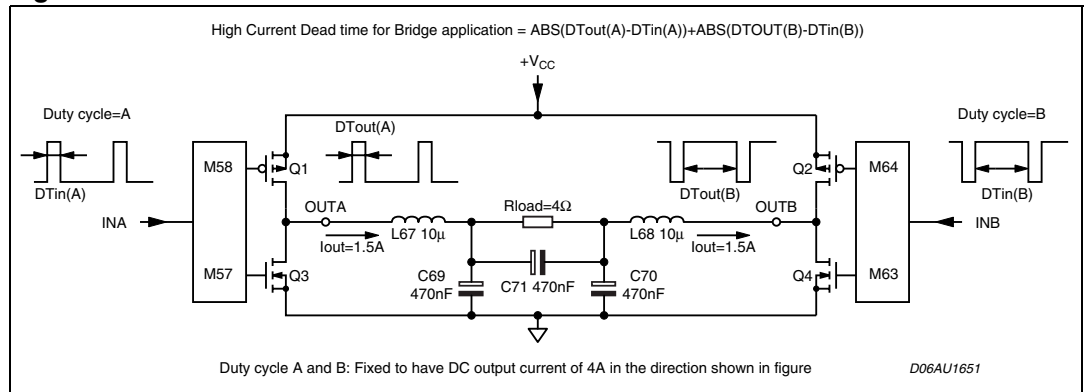

Figure 5. Test circuit 2



4 Processing data paths

www.datasheet4u.com

Here after some pictures that represent the data processing paths inside STA335BWS. A first 2x oversampling FIR filter allows a $2 \cdot f_s$ audio processing. Then a selectable high pass filter removes the DC level. 4 biquads filter allow a full equalization system. A final crossover filter is present. This filter can eventually be used as a fifth biquad stage, see the I²C registers settings for this specific usage. A prescaler and a final post scaler allow a full control over the signal dynamic respectively before and after the filtering stages. A mixer function is also available.

Figure 6. STA335BWS processing data flow

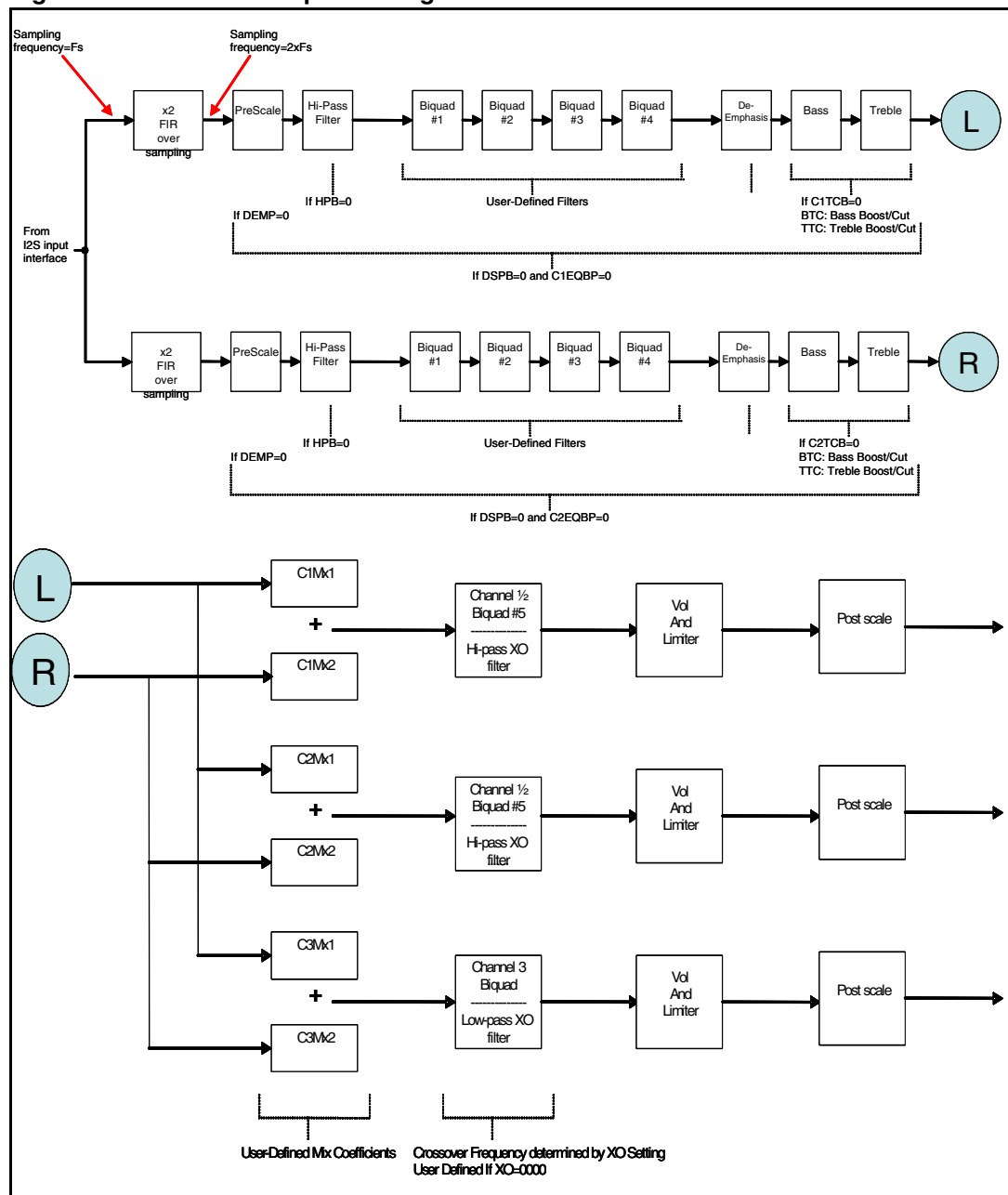

5 I²C bus specification

www.datasheet4u.com

The STA335BWS supports the I²C protocol via the input ports SCL and SDA_IN (master to slave) and the output port SDA_OUT (slave to master). This protocol defines any device that sends data on to the bus as a transmitter and any device that reads the data as a receiver. The device that controls the data transfer is known as the master and the other as the slave. The master always starts the transfer and provides the serial clock for synchronization. STA335BWS is always a slave device in all of its communications. It supports up to 400 kb/s (fast-mode bit rate). STA335BWS I²C is a slave only interface.

5.1 Communication protocol

5.1.1 Data transition or change

Data changes on the SDA line must only occur when the SCL clock is low. SDA transition while the clock is high is used to identify a START or STOP condition.

5.1.2 Start condition

START is identified by a high to low transition of the data bus SDA signal while the clock signal SCL is stable in the high state. A START condition must precede any command for data transfer.

5.1.3 Stop condition

STOP is identified by low to high transition of the data bus SDA signal while the clock signal SCL is stable in the high state. A STOP condition terminates communication between STA335BWS and the bus master.

5.1.4 Data input

During the data input the STA335BWS samples the SDA signal on the rising edge of clock SCL. For correct device operation the SDA signal must be stable during the rising edge of the clock and the data can change only when the SCL line is low.

5.2 Device addressing

To start communication between the master and the STA335BWS, the master must initiate with a start condition. Following this, the master sends onto the SDA line 8-bits (MSB first) corresponding to the device select address and read or write mode.

The seven most significant bits are the device address identifiers, corresponding to the I²C bus definition. In the STA335BWS the I²C interface has two device addresses depending on the SA port configuration, 0x38 when SA = 0, and 0x3A when SA = 1.

The eighth bit (LSB) identifies read or write operation RW, this bit is set to 1 in read mode and 0 for write mode. After a START condition the STA335BWS identifies on the bus the device address and if a match is found, it acknowledges the identification on SDA bus during the 9th bit time. The byte following the device identification byte is the internal space address.

5.3 Write operation

Following the START condition the master sends a device select code with the RW bit set to 0. The STA335BWS acknowledges this and the writes for the byte of internal address. After receiving the internal byte address the STA335BWS again responds with an acknowledgement.

www.datasheet4u.com

5.3.1 Byte write

In the byte write mode the master sends one data byte, this is acknowledged by the STA335BWS. The master then terminates the transfer by generating a STOP condition.

5.3.2 Multi-byte write

The multi-byte write modes can start from any internal address. The master generating a STOP condition terminates the transfer.

5.4 Read operation

5.4.1 Current address byte read

Following the START condition the master sends a device select code with the RW bit set to 1. The STA335BWS acknowledges this and then responds by sending one byte of data. The master then terminates the transfer by generating a STOP condition.

5.4.2 Current address multi-byte read

The multi-byte read modes can start from any internal address. Sequential data bytes are read from sequential addresses within the STA335BWS. The master acknowledges each data byte read and then generates a STOP condition terminating the transfer.

5.4.3 Random address byte read

Following the START condition the master sends a device select code with the RW bit set to 0. The STA335BWS acknowledges this and then the master writes the internal address byte. After receiving, the internal byte address the STA335BWS again responds with an acknowledgement. The master then initiates another START condition and sends the device select code with the RW bit set to 1. The STA335BWS acknowledges this and then responds by sending one byte of data. The master then terminates the transfer by generating a STOP condition.

5.4.4 Random address multi-byte read

The multi-byte read modes could start from any internal address. Sequential data bytes are read from sequential addresses within the STA335BWS. The master acknowledges each data byte read and then generates a STOP condition terminating the transfer.

5.4.5 Write mode sequence

Figure 7. Write mode sequence

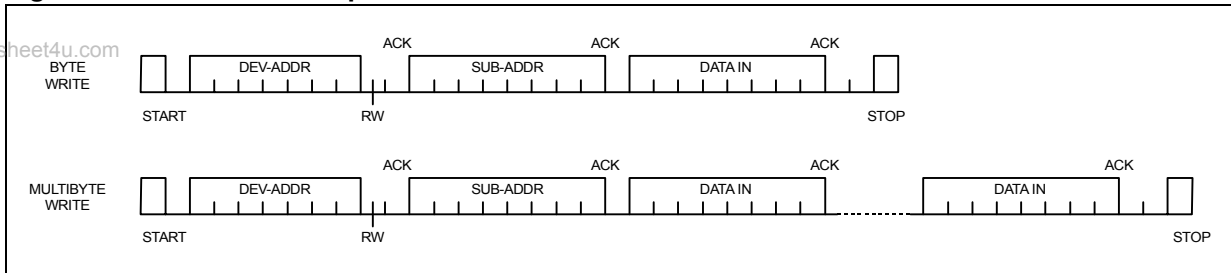

www.datasheet4u.com

5.4.6 Read mode sequence

Figure 8. Read mode sequence

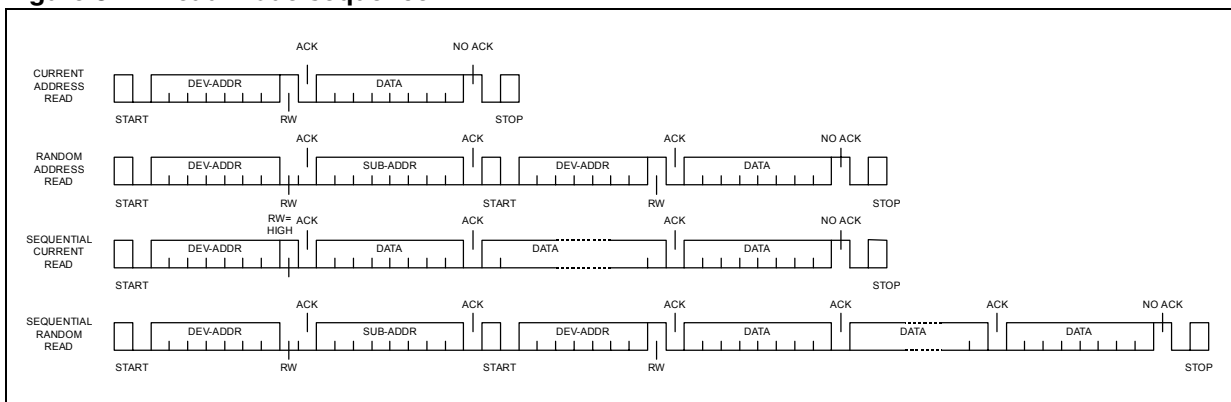

6 Register description

Table 9. Register summary

Addr	Name	D7	D6	D5	D4	D3	D2	D1	D0
0x00	ConfA	FDRB	TWAB	TWRB	IR1	IR0	MCS2	MCS1	MCS0
0x01	ConfB	C2IM	C1IM	DSCKE	SAIFB	SAI3	SAI2	SAI1	SAI0
0x02	ConfC	OCRB		CSZ3	CSZ2	CSZ1	CSZ0	OM1	OM0
0x03	ConfD	MME	ZDE	DRC	BQL	PSL	DSPB	DEMP	HPB
0x04	ConfE	SVE	ZCE	DCCV	PWMS	AME	NSBW	MPC	MPCV
0x05	ConfF	EAPD	PWDN	ECLC	LDTE	BCLE	IDE	OCFG1	OCFG0
0x06	Mute/LOC	LOC1	LOC0			C3M	C2M	C1M	MMute
0x07	Mvol	MV7	MV6	MV5	MV4	MV3	MV2	MV1	MV0
0x08	C1Vol	C1V7	C1V6	C1V5	C1V4	C1V3	C1V2	C1V1	C1V0
0x09	C2Vol	C2V7	C2V6	C2V5	C2V4	C2V3	C2V2	C2V1	C2V0
0x0A	C3Vol	C3V7	C3V6	C3V5	C3V4	C3V3	C3V2	C3V1	C3V0
0x0B	Auto1			AMGC1	AMGC0				
0x0C	Auto2	XO3	XO2	XO1	XO0	AMAM2	AMAM1	AMAM0	AMAME
0x0D	Auto3								
0x0E	C1Cfg	C1OM1	C1OM0	C1LS1	C1LS0	C1BO	C1VBP	C1EQBP	C1TCB
0x0F	C2Cfg	C2OM1	C2OM0	C2LS1	C2LS0	C2BO	C2VBP	C2EQBP	C2TCB
0x10	C3Cfg	C3OM1	C3OM0	C3LS1	C3LS0	C3BO	C3VBP		
0x11	Tone	TTC3	TTC2	TTC1	TTC0	BTC3	BTC2	BTC1	BTC0
0x12	L1ar	L1A3	L1A2	L1A1	L1A0	L1R3	L1R2	L1R1	L1R0
0x13	L1atrt	L1AT3	L1AT2	L1AT1	L1AT0	L1RT3	L1RT2	L1RT1	L1RT0
0x14	L2ar	L2A3	L2A2	L2A1	L2A0	L2R3	L2R2	L2R1	L2R0
0x15	L2atrt	L2AT3	L2AT2	L2AT1	L2AT0	L2RT3	L2RT2	L2RT1	L2RT0
0x16	Cfaddr			CFA5	CFA4	CFA3	CFA2	CFA1	CFA0
0x17	B1cf1	C1B23	C1B22	C1B21	C1B20	C1B19	C1B18	C1B17	C1B16
0x18	B1cf2	C1B15	C1B14	C1B13	C1B12	C1B11	C1B10	C1B9	C1B8
0x19	B1cf3	C1B7	C1B6	C1B5	C1B4	C1B3	C1B2	C1B1	C1B0
0x1A	B2cf1	C2B23	C2B22	C2B21	C2B20	C2B19	C2B18	C2B17	C2B16
0x1B	B2cf2	C2B15	C2B14	C2B13	C2B12	C2B11	C2B10	C2B9	C2B8
0x1C	B2cf3	C2B7	C2B6	C2B5	C2B4	C2B3	C2B2	C2B1	C2B0
0x1D	A1cf1	C3B23	C3B22	C3B21	C3B20	C3B19	C3B18	C3B17	C3B16
0x1E	A1cf2	C3B15	C3B14	C3B13	C3B12	C3B11	C3B10	C3B9	C3B8
0x1F	A1cf3	C3B7	C3B6	C3B5	C3B4	C3B3	C3B2	C3B1	C3B0

Table 9. Register summary (continued)

Addr	Name	D7	D6	D5	D4	D3	D2	D1	D0
0x20	A2cf1	C4B23	C4B22	C4B21	C4B20	C4B19	C4B18	C4B17	C4B16
0x21	A2cf2	C4B15	C4B14	C4B13	C4B12	C4B11	C4B10	C4B9	C4B8
0x22	A2cf3	C4B7	C4B6	C4B5	C4B4	C4B3	C4B2	C4B1	C4B0
0x23	B0cf1	C5B23	C5B22	C5B21	C5B20	C5B19	C5B18	C5B17	C5B16
0x24	B0cf2	C5B15	C5B14	C5B13	C5B12	C5B11	C5B10	C5B9	C5B8
0x25	B0cf3	C5B7	C5B6	C5B5	C5B4	C5B3	C5B2	C5B1	C5B0
0x26	Cfud					RA	R1	WA	W1
0x27	MPCC1	MPCC15	MPCC14	MPCC13	MPCC12	MPCC11	MPCC10	MPCC9	MPCC8
0x28	MPCC2	MPCC7	MPCC6	MPCC5	MPCC4	MPCC3	MPCC2	MPCC1	MPCC0
0x29	DCC1	DCC15	DCC14	DCC13	DCC12	DCC11	DCC10	DCC9	DCC8
0x2A	DCC2	DCC7	DCC6	DCC5	DCC4	DCC3	DCC2	DCC1	DCC0
0x2B	FDRC1	FDRC15	FDRC14	FDRC13	FDRC12	FDRC11	FDRC10	FDRC9	FDRC8
0x2C	FDRC2	FDRC7	FDRC6	FDRC5	FDRC4	FDRC3	FDRC2	FDRC1	FDRC0
0x2D	Status	PLLUL	FAULT	UVFAULT	OVFAULT	OCFAULT	OCWARN	TFAULT	TWARN
0x2E	reserved			RO1BACT	R5BACT	R4BACT	R3BACT	R2BACT	R1BACT
0x2F	reserved			R01BEND	R5BEND	R4BEND	R3BEND	R2BEND	R1BEND
0x30	reserved				R5BBAD	R4BBAD	R3BBAD	R2BBAD	R1BBAD
0x31	EQCFG	XOB			AMGC3	AMGC2	reserved	SEL1	SEL0

6.1 Configuration register A (addr 0x00)

www.datasheet4u.com

D7	D6	D5	D4	D3	D2	D1	D0
FDRB	TWAB	TWRB	IR1	IR0	MCS2	MCS1	MCS0
0	1	1	0	0	0	1	1

6.1.1 Master clock select

Bit	R/W	RST	Name	Description
0	R/W	1	MCS0	Selects the ratio between the input I ² S sample frequency and the input clock.
1	R/W	1	MCS1	
2	R/W	0	MCS2	

The STA335BWS supports sample rates of 32 kHz, 44.1 kHz, 48 kHz, 88.2 kHz, 96 kHz, 176.4 kHz, and 192 kHz. Therefore the internal clock is:

- 32.768 MHz for 32 kHz
- 45.1584 MHz for 44.1 kHz, 88.2 kHz, and 176.4 kHz
- 49.152 MHz for 48 kHz, 96 kHz, and 192 kHz

The external clock frequency provided to the XTI pin must be a multiple of the input sample frequency (f_s).

The relationship between the input clock and the input sample rate is determined by both the MCSx and the IR (input rate) register bits. The MCSx bits determine the PLL factor generating the internal clock and the IR bit determines the oversampling ratio used internally

Table 10. Input sampling rates

Input sample rate f_s (kHz)	IR	MCS[2:0]					
		101	100	011	010	001	000
32, 44.1, 48	00	576fs	128fs	256fs	384fs	512fs	768fs
88.2, 96	01	NA	64fs	128fs	192fs	256fs	384fs
176.4, 192	1X	NA	32fs	64fs	96fs	128fs	192fs

6.1.2 Interpolation ratio select

www.datasheet4u.com

Bit	R/W	RST	Name	Description
4:3	R/W	00	IR[1:0)	Selects internal interpolation ratio based on input I ² S sample frequency

The STA335BWS has variable interpolation (oversampling) settings such that internal processing and DDX output rates remain consistent. The first processing block interpolates by either 2 times or 1 time (pass-through) or provides a 2 times downsample. The oversampling ratio of this interpolation is determined by the IR bits.

Table 11. IR bit settings as a function of input sample rate

Input sample rate Fs (kHz)	IR	1st stage interpolation ratio
32	00	2 times oversampling
44.1	00	2 times oversampling
48	00	2 times oversampling
88.2	01	Pass-through
96	01	Pass-through
176.4	10	2 times downsampling
192	10	2 times downsampling

6.1.3 Thermal warning recovery bypass

Bit	R/W	RST	Name	Description
5	R/W	1	TWRB	0: Thermal warning recovery enabled 1: Thermal warning recovery disabled

If the thermal warning adjustment is enabled (TWAB = 0), then the thermal warning recovery determines if the -3 dB output limit is removed when thermal warning is negative.

If TWRB = 0 and TWAB = 0, then when a thermal warning disappears the -3 dB output limit is removed and the gain is added back to the system. If TWRB = 1 and TWAB = 0, then when a thermal warning disappears the -3 dB output limit remains until TWRB is changed to zero or the device is reset.

6.1.4 Thermal warning adjustment bypass

www.datasheet4u.com

Bit	R/W	RST	Name	Description
6	R/W	1	TWAB	0: Thermal warning adjustment enabled 1: Thermal warning adjustment disabled

The on-chip STA335BWS power output block provides feedback to the digital controller using inputs to the power control block. The TWARN input is used to indicate a thermal warning condition. When TWARN is asserted (set to 0) for a period of time greater than 400 ms, the power control block forces a -3 dB output limit (determined by TWOCL in the coefficient RAM) to the modulation limit in an attempt to eliminate the thermal warning condition. Once the thermal warning output limit adjustment is applied, it remains in this state until reset, unless FDRB = 0.

6.1.5 Fault detect recovery bypass

Bit	R/W	RST	Name	Description
7	R/W	0	FDRB	0: fault detect recovery enabled 1: fault detect recovery disabled

The on-chip STA335BWS power output block provides feedback to the digital controller using inputs to the power control block. The FAULT input is used to indicate a fault condition (either over-current or thermal). When FAULT is asserted (set to 0), the power control block attempts a recovery from the fault by asserting the tri-state output (setting it to 0 which directs the power output block to begin recovery), holds it at 0 for period of time in the range of 0.1 ms to 1 s as defined by the fault-detect recovery constant register (FDRC registers 0x29, 0x2A), then toggles it back to 1. This sequence is repeated as long as the fault indication exists. This feature is enabled by default but can be bypassed by setting the FDRB control bit to 1.

6.2 Configuration register B (addr 0x01)

D7	D6	D5	D4	D3	D2	D1	D0
C2IM	C1IM	DSCKE	SAIFB	SAI3	SAI2	SAI1	SAI0
1	0	0	0	0	0	0	0

6.2.1 Serial audio input interface format

Bit	R/W	RST	Name	Description
0	R/W	0	SAI0	Determines the interface format of the input serial digital audio interface.
1	R/W	0	SAI1	
2	R/W	0	SAI2	
3	R/W	0	SAI3	

6.2.2 Serial data interface

www.datasheet4u.com

The STA335BWS audio serial input was designed to interface with standard digital audio components and to accept a number of serial data formats. STA335BWS always acts a slave when receiving audio input from standard digital audio components. Serial data for two channels is provided using three inputs: left/right clock LRCKI, serial clock BICKI, and serial data 1 and 2 SDI12.

The SAI register (configuration register B (0x01), bits D3 to D0) and the SAIFB register (configuration register B (0x01), bit D4) are used to specify the serial data format. The default serial data format is I²S, MSB-first. Available formats are shown in the tables and figure that follow.

6.2.3 Serial data first bit

SAIFB	Format
0	MSB-first
1	LSB-first

Table 12. Support serial audio input formats for MSB-first (SAIFB = 0)

BICKI	SAI [3:0]	SAIFB	Interface format
32fs	0000	0	I ² S 15-bit data
	0001	0	Left/right-justified 16-bit data
48fs	0000	0	I ² S 16 to 23-bit data
	0001	0	Left-justified 16 to 24-bit data
	0010	0	Right-justified 24-bit data
	0110	0	Right-justified 20-bit data
	1010	0	Right-justified 18-bit data
	1110	0	Right-justified 16-bit data
64fs	0000	0	I ² S 16 to 24-bit data
	0001	0	Left-justified 16 to 24-bit data
	0010	0	Right-justified 24-bit data
	0110	0	Right-justified 20-bit data
	1010	0	Right-justified 18-bit data
	1110	0	Right-justified 16-bit data

Table 13. Supported serial audio input formats for LSB-first (SAIFB = 1)

BICKI	SAI [3:0]	SAIFB	Interface Format
32fs	1100	1	I ² S 15-bit data
	1110	1	Left/right-justified 16-bit data
48fs	0100	1	I ² S 23-bit data
	0100	1	I ² S 20-bit data
	1000	1	I ² S 18-bit data
	1100	1	LSB first I ² S 16-bit data
	0001	1	Left-justified 24-bit data
	0101	1	Left-justified 20-bit data
	1001	1	Left-justified 18-bit data
	1101	1	Left-justified 16-bit data
	0010	1	Right-justified 24-bit data
	0110	1	Right-justified 20-bit data
	1010	1	Right-justified 18-bit data
	1110	1	Right-justified 16-bit data
64fs	0000	1	I ² S 24-bit data
	0100	1	I ² S 20-bit data
	1000	1	I ² S 18-bit data
	1100	1	LSB first I ² S 16-bit data
	0001	1	Left-justified 24-bit data
	0101	1	Left-justified 20-bit data
	1001	1	Left-justified 18-bit data
	1101	1	Left-justified 16-bit data
	0010	1	Right-justified 24-bit data
	0110	1	Right-justified 20-bit data
	1010	1	Right-justified 18-bit data
	1110	1	Right-justified 16-bit data

www.datasheet4u.com

6.2.4 Delay serial clock enable

Bit	R/W	RST	Name	Description
5	R/W	0	DSCKE	0: No serial clock delay 1: Serial clock delay by 1 core clock cycle to tolerate anomalies in some I2S master devices

6.2.5 Channel input mapping

www.datasheet4u.com

Bit	R/W	RST	Name	Description
6	R/W	0	C1IM	0: Processing channel 1 receives Left I ² S Input 1: Processing channel 1 receives Right I ² S Input
7	R/W	1	C2IM	0: Processing channel 2 receives Left I ² S Input 1: Processing channel 2 receives Right I ² S Input

Each channel received via I²S can be mapped to any internal processing channel via the Channel Input Mapping registers. This allows for flexibility in processing. The default settings of these registers map each I²S input channel to its corresponding processing channel.

6.3 Configuration register C (addr 0x02)

D7	D6	D5	D4	D3	D2	D1	D0
OCRB	Reserved	CSZ3	CSZ2	CSZ1	CSZ0	OM1	OM0
1		0	1	0	1	1	1

6.3.1 DDX power output mode

Bit	R/W	RST	Name	Description
0	R/W	1	OM0	Selects configuration of DDX output.
1	R/W	1	OM1	

The DDX power output mode selects how the DDX output timing is configured. Different power devices use different output modes.

Table 14. Output modes

OM[1,0]	Output stage mode
00	Drop compensation
01	Discrete output stage - tapered compensation
10	Full power mode
11	Variable drop compensation (CSZx bits)

6.3.2 DDX compensating pulse size register

www.datasheet4u.com

Bit	R/W	RST	Name	Description
2	R/W	1	CSZ0	When OM[1,0] = 11, this register determines the size of the DDX compensating pulse from 0 clock ticks to 15 clock periods.
3	R/W	0	CSZ1	
4	R/W	1	CSZ2	
5	R/W	0	CSZ3	

Table 15. Compensating pulse size

CSZ[3:0]	Compensating Pulse Size
0000	0 ns (0 tick) compensating pulse size
0001	20 ns (1 tick) clock period compensating pulse size
...	...
1111	300 ns (15 ticks) clock period compensating pulse size

6.3.3 Over-current warning detect adjustment bypass

Bit	R/W	RST	Name	Description
7	R/W	1	OCRB	0: Over-Current warning Adjustment enabled 1: Over-Current warning Adjustment disabled

The OCWARN input is used to indicate an over-current warning condition. When OCWARN is asserted (set to 0), the power control block forces an adjustment to the modulation limit (default is -3 dB) in an attempt to eliminate the over-current warning condition. Once the over-current warning volume adjustment is applied, it remains in this state until reset is applied. The level of adjustment can be changed via the TWOCL (thermal warning/over current limit) setting which is address 0x37 of the user defined coefficient RAM.

6.4 Configuration register D (addr 0x03)

D7	D6	D5	D4	D3	D2	D1	D0
MME	ZDE	DRC	BQL	PSL	DSPB	DEMP	HPB
0	1	0	0	0	0	0	0

6.4.1 High-pass filter bypass

Bit	R/W	RST	Name	Description
0	R/W	0	HPB	Setting of one bypasses internal AC coupling digital high-pass filter

The STA335BWS features an internal digital high-pass filter for the purpose of AC coupling. The purpose of this filter is to prevent DC signals from passing through a DDX amplifier. DC signals can cause speaker damage. When HPB = 0, this filter is enabled.

6.4.2 De-emphasis

www.datasheet4u.com

Bit	R/W	RST	Name	Description
1	R/W	0	DEMP	0: No de-emphasis 1: De-emphasis

Setting the DEMP bit enables de-emphasis on all channels

6.4.3 DSP bypass

Bit	R/W	RST	Name	Description
2	R/W	0	DSPB	0: Normal operation 1: Bypass of biquad and bass/treble functionality

Setting the DSPB bit bypasses the EQ functionality of the STA335BWS.

6.4.4 Post-scale link

Bit	R/W	RST	Name	Description
3	R/W	0	PSL	0: Each channel uses individual post-scale value 1: Each channel uses channel 1 post-scale value

Post-scale functionality can be used for power-supply error correction. For multi-channel applications running off the same power-supply, the post-scale values can be linked to the value of channel 1 for ease of use and update the values faster.

6.4.5 Biquad coefficient link

Bit	R/W	RST	Name	Description
4	R/W	0	BQL	0: Each channel uses coefficient values 1: Each channel uses channel 1 coefficient values

For ease of use, all channels can use the biquad coefficients loaded into the Channel 1 Coefficient RAM space by setting the BQL bit to 1. Therefore, any EQ updates only have to be performed once.

6.4.6 Dynamic range compression/anti-clipping bit

www.datasheet4u.com

Bit	R/W	RST	Name	Description
5	R/W	0	DRC	0: Limiters act in anti-clipping mode 1: Limiters act in dynamic range compression mode

Both limiters can be used in one of two ways, anti-clipping or dynamic range compression. When used in anti-clipping mode the limiter threshold values are constant and dependent on the limiter settings. In dynamic range compression mode the limiter threshold values vary with the volume settings allowing a nighttime listening mode that provides a reduction in the dynamic range regardless of the volume level.

6.4.7 Zero-detect mute enable

Bit	R/W	RST	Name	Description
6	R/W	1	ZDE	Setting of 1 enables the automatic zero-detect mute

Setting the ZDE bit enables the zero-detect automatic mute. The zero-detect circuit looks at the data for each processing channel at the output of the crossover (bass management) filter. If any channel receives 2048 consecutive zero value samples (regardless of fs) then that individual channel is muted if this function is enabled.

6.4.8 Miami Mode™ enable

Bit	R/W	RST	Name	Description
7	R/W	0	MME	0: Sub Mix into Left/Right Disabled 1: Sub Mix into Left/Right Enabled

6.5 Configuration register E (addr 0x04)

D7	D6	D5	D4	D3	D2	D1	D0
SVE	ZCE	DCCV	PWMS	AME	NSBW	MPC	MPCV
1	1	0	0	0	0	1	0

6.5.1 Max power correction variable

Bit	R/W	RST	Name	Description
0	R/W	0	MPCV	0: Use standard MPC coefficient 1: Use MPCC bits for MPC coefficient

6.5.2 Max power correction

Bit	R/W	RST	Name	Description
1	R/W	1	MPC	Setting of 1 enables Power Bridge correction for THD reduction near maximum power output.

www.datasheet4u.com

Setting the MPC bit turns on special processing that corrects the STA335BWS power device at high power. This mode should lower the THD+N of a full DDX system at maximum power output and slightly below. If enabled, MPC is operational in all output modes except tapered (OM[1,0] = 01) and binary. When OCFG = 00, MPC will not effect channels 3 and 4, the line-out channels.

6.5.3 Noise-shaper bandwidth selection

Bit	R/W	RST	Name	Description
2	R/W	0	NSBW	1: Third order NS 0: Fourth order NS

6.5.4 AM mode enable

Bit	R/W	RST	Name	Description
3	R/W	0	AME	0: Normal DDX operation. 1: AM reduction mode DDX operation

STA335BWS features a DDX processing mode that minimizes the amount of noise generated in frequency range of AM radio. This mode is intended for use when DDX is operating in a device with an AM tuner active. The SNR of the DDX processing is reduced to ~83 dB in this mode, which is still greater than the SNR of AM radio.

6.5.5 PWM speed mode

Bit	R/W	RST	Name	Description
4	R/W	0	PWMS	0: Normal speed (384 kHz) all channels 1: Odd speed (341.3 kHz) all channels

6.5.6 Distortion compensation variable enable

Bit	R/W	RST	Name	Description
5	R/W	0	DCCV	0: Uses preset DC coefficient 1: Uses DCC coefficient

6.5.7 Zero-crossing volume enable

www.datasheet4u.com

Bit	R/W	RST	Name	Description
6	R/W	1	ZCE	1: Volume adjustments only occur at digital zero-crossings 0: Volume adjustments occur immediately

The ZCE bit enables zero-crossing volume adjustments. When volume is adjusted on digital zero-crossings no clicks are audible.

6.5.8 Soft volume update enable

Bit	R/W	RST	Name	Description
7	R/W	1	SVE	1: Volume adjustments ramp according to SVR settings 0: Volume adjustments occur immediately

6.6 Configuration register F (addr 0x05)

D7	D6	D5	D4	D3	D2	D1	D0
EAPD	PWDN	ECLE	LDTE	BCLE	IDE	OCFG1	OCFG0
0	1	0	1	1	1	0	0

6.6.1 Output configuration

Bit	R/W	RST	Name	Description
0	R/W	0	OCFG0	Selects the output configuration
1	R/W	0	OCFG1	

Table 16. Output configuration engine selection

OCFG[1:0]	Output configuration	Config pin
00	2 channel (full-bridge) power, 2 channel data-out: 1A/1B → 1A/1B 2A/2B → 2A/2B LineOut1 → 3A/3B LineOut2 → 4A/4B Line Out Configuration determined by LOC register	0
01	2 (half-bridge), 1 (full-bridge) on-board power: 1A → 1A, Binary 0° 2A → 1B, Binary 90° 3A/3B → 2A/2B, Binary 45° 1A/B → 3A/B, Binary 0° 2A/B → 4A/B, Binary 90°	0

Table 16. Output configuration engine selection (continued)

OCFG[1:0]	Output configuration	Config pin
10	2 channel (full-bridge) power, 1 channel DDX: 1A/1B → 1A/1B 2A/2B → 2A/2B 3A/3B → 3A/3B EAPDEXT and TWARDNEXT Active	0
11	1 channel mono-parallel: 3A → 1A/1B, w/ C3BO 45° 3B → 2A/2B, w/ C3BO 45° 1A/1B → 3A/3B 2A/2B → 4A/4B	1

www.datasheet4u.com

Note: To the left of the arrow is the processing channel. When using channel output mapping, any of the three processing channel outputs can be used for any of the three inputs.

Figure 9. OCFG = 00 (default value)

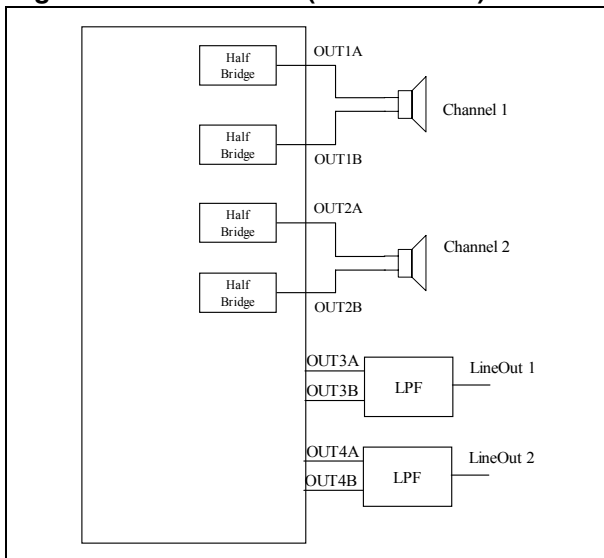

Figure 10. OCFG = 01

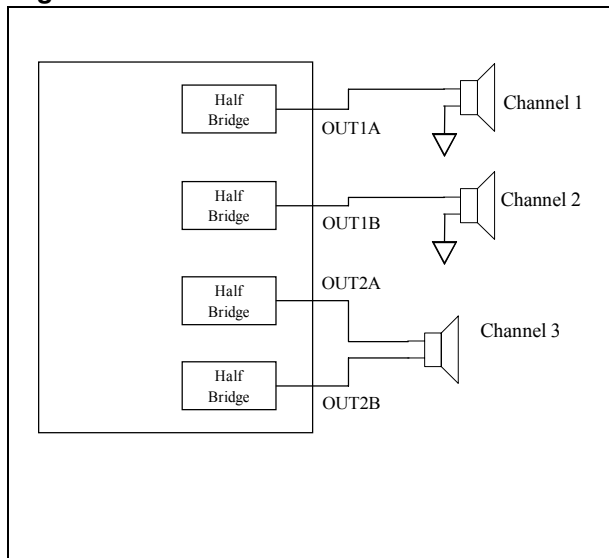
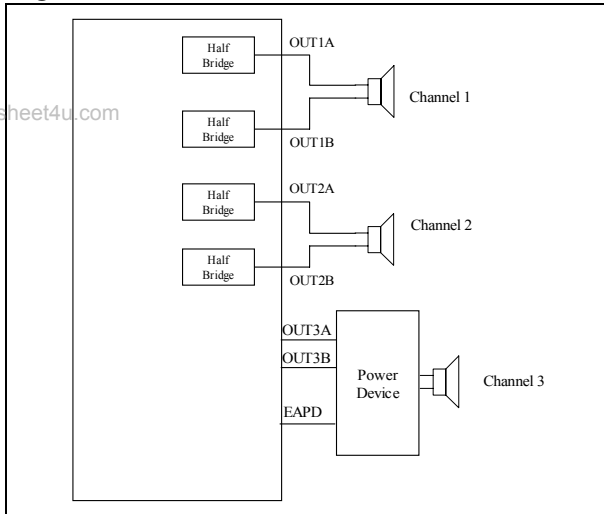
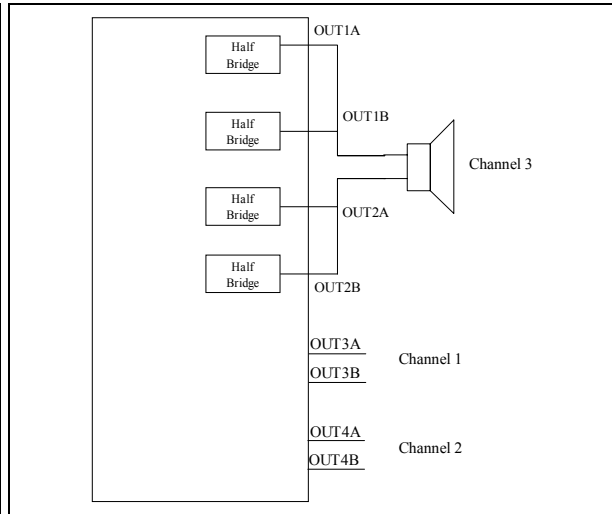

Figure 11. OCFG = 10



OCFG = 11



STA335BWS can be configured to support different output configurations. For each PWM output channel a PWM slot is defined. The PWM slot always has a time duration of $1/(8 * F_s)$ seconds. The PWM slot defines the maximum extension for PWM rising and falling edges, that is, rising edge as far as the falling edge cannot range outside PWM slot boundaries.

Figure 12. STA335BWS output mapping scheme

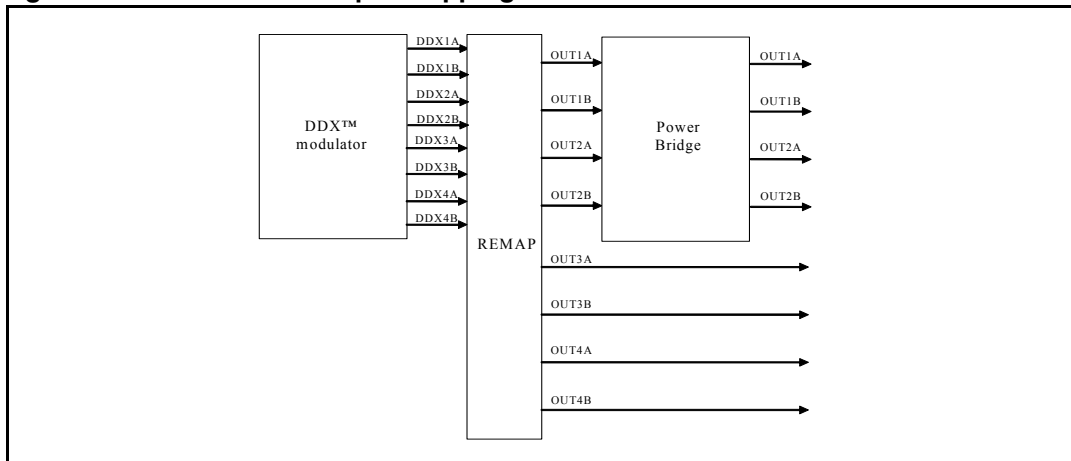

For each configuration the PWM from the digital driver are mapped in different way to the power stage:

2.0 channels, two full bridges (OCFG = 00):

www.datasheet4u.com

- DDX1A ' OUT1A
- DDX1B ' OUT1B
- DDX2A ' OUT2A
- DDX2B ' OUT2B
- DDX3A ' OUT3A
- DDX3B ' OUT3B
- DDX4A ' OUT4A
- DDX4B ' OUT4B
- DDX1A/1B configured as ternary
- DDX2A/2B configured as ternary
- DDX3A/3B configured as line-out ternary
- DDX4A/4B configured as line-out ternary

On channel 3 line out (LOC bits = 00) the same data as channel 1 processing are sent. On channel 4 line out (LOC bits = 00) the same data as channel 2 processing are sent. In this configuration, no volume control or EQ have effect on channel 3 and 4.

In this configuration the PWM slot phase is the following as shown in the next figures.

Figure 13. 2.0 channels (OCFG = 00) PWM slots

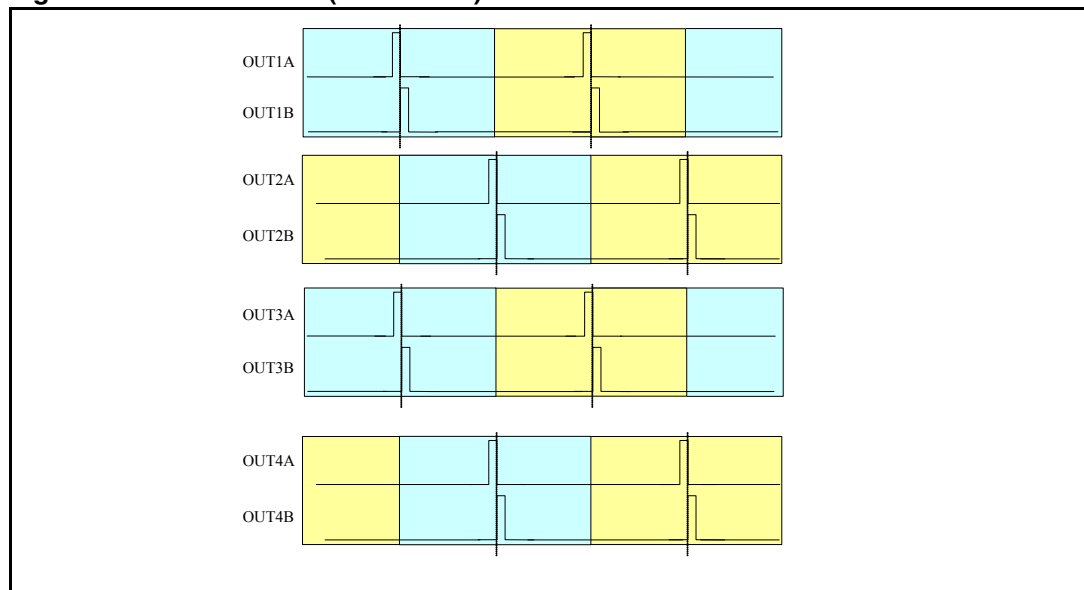

www.datasheet4u.com

2.1 channels, two half bridges + one full bridge (OCFG = 01):

- DDX1A ' OUT1A
- DDX2A ' OUT1B
- DDX3A ' OUT2A
- DDX3B ' OUT2B
- DDX1A ' OUT3A
- DDX1B ' OUT3B
- DDX2A ' OUT4A
- DDX2B ' OUT4B
- DDX1A/1B configured as binary
- DDX2A/2B configured as binary
- DDX3A/3B configured as binary
- DDX4A/4B is not used

In this configuration, channel 3 has full control (for example, on volume and EQ). On OUT3/OUT4 channels the channel 1 and channel 2 PWM are replicated.

In this configuration the PWM slot phase is the following as shown in the next figures:

Figure 14. 2.1 channels (OCFG = 01) PWM slots

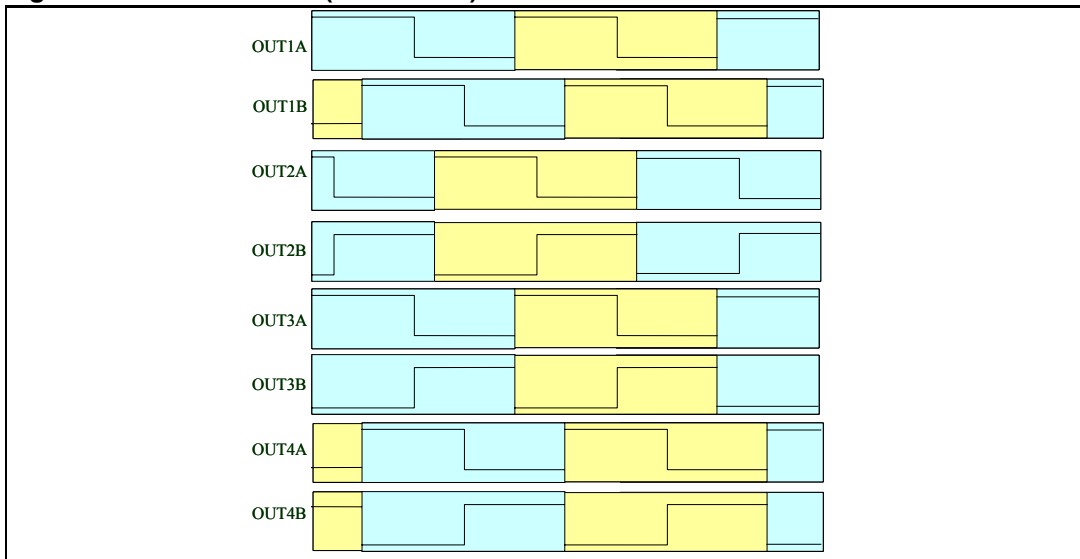

www.datasheet4u.com

2.1 channels, two fullbridge + one external full bridge (OCFG = 10):

- DDX1A ' OUT1A
- DDX1B ' OUT1B
- DDX2A ' OUT2A
- DDX2B ' OUT2B
- DDX3A ' OUT3A
- DDX3B ' OUT3B
- EAPD ' OUT4A
- TWARN OUT4B
- DDX1A/1B configured as ternary
- DDX2A/2B configured as ternary
- DDX3A/3B configured as ternary
- DDX4A/4B is not used

In this configuration, channel 3 has full control (volume, EQ, etc...). On OUT4 channel the external bridge control signals are muxed.

In this configuration the PWM slot phase is the following as shown in the next figures:

Figure 15. 2.1 channels (OCFG = 10) PWM slots

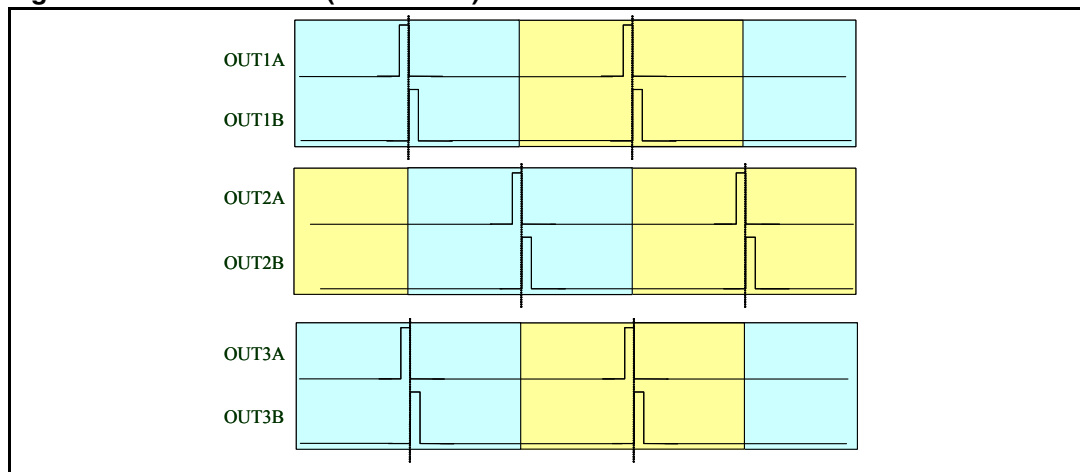

6.6.2 Invalid input detect mute enable

Bit	R/W	RST	Name	Description
2	R/W	1	IDE	Setting of 1 enables the automatic invalid input detect mute

Setting the IDE bit enables this function, which looks at the input I²S data and will automatically mute if the signals are perceived as invalid.

6.6.3 Binary output mode clock loss detection

www.datasheet4u.com

Bit	R/W	RST	Name	Description
3	R/W	1	BCLE	Binary output mode clock loss detection enable

Detects loss of input MCLK in binary mode and will output 50% duty cycle.

6.6.4 LRCK double trigger protection

Bit	R/W	RST	Name	Description
4	R/W	1	LDTE	LRCLK double trigger protection enable

Actively prevents double trigger of LRCLK.

6.6.5 Auto EAPD on clock loss

Bit	R/W	RST	Name	Description
5	R/W	0	ECLE	Auto EAPD on clock loss

When active, issues a power device power down signal (EAPD) on clock loss detection.

6.6.6 IC power down

Bit	R/W	RST	Name	Description
7	R/W	1	PWDN	0: IC power down low-power condition 1: IC normal operation

The PWDN register is used to place the IC in a low-power state. When PWDN is written as 0, the output begins a soft-mute. After the mute condition is reached, EAPD is asserted to power down the power-stage, then the master clock to all internal hardware except the I²C block is gated. This places the IC in a very low power consumption state.

6.6.7 External amplifier power down

Bit	R/W	RST	Name	Description
7	R/W	0	EAPD	0: External power stage power down active 1: Normal operation

The EAPD register directly disables/enables the internal power circuitry.

When EAPD = 0, the internal power section is placed on a low-power state (disabled). This register also controls the DDX4B/EAPD output pin when OCFG = 10.

6.7 Volume control registers (addr 0x06 to 0x0A)

6.7.1 Mute/line output configuration register

www.datasheet4u.com

D7	D6	D5	D4	D3	D2	D1	D0
LOC1	LOC0	Reserved		C3M	C2M	C1M	MMUTE
0	0			0	0	0	0

LOC[1:0]	Line output configuration
00	Line output fixed - no volume, no EQ
01	Line output variable - CH3 volume effects line output, no EQ
10	Line output variable with EQ - CH3 volume effects line output

Line output is only active when OCFG = 00. In this case LOC determines the line output configuration. The source of the line output is always the channel 1 and 2 inputs.

6.7.2 Master volume register

D7	D6	D5	D4	D3	D2	D1	D0
MV7	MV6	MV5	MV4	MV3	MV2	MV1	MV0
1	1	1	1	1	1	1	1

6.7.3 Channel 1 volume

D7	D6	D5	D4	D3	D2	D1	D0
C1V7	C1V6	C1V5	C1V4	C1V3	C1V2	C1V1	C1V0
0	1	1	0	0	0	0	0

6.7.4 Channel 2 volume

D7	D6	D5	D4	D3	D2	D1	D0
C2V7	C2V6	C2V5	C2V4	C2V3	C2V2	C2V1	C2V0
0	1	1	0	0	0	0	0

6.7.5 Channel 3 and line-output volume

www.datasheet4u.com

D7	D6	D5	D4	D3	D2	D1	D0
C3V7	C3V6	C3V5	C3V4	C3V3	C3V2	C3V1	C3V0
0	1	1	0	0	0	0	0

The Volume structure of the STA335BWS consists of individual volume registers for each channel and a master volume register that provides an offset to each channels volume setting. The individual channel volumes are adjustable in 0.5 dB steps from +48 dB to -80 dB.

As an example if C3V = 0x00 or +48 dB and MV = 0x18 or -12 dB, then the total gain for channel 3 = +36 dB.

The Master Mute when set to 1 mutes all channels at once, whereas the individual channel mutes (CxM) mutes only that channel. Both the master mute and the channel mutes provide a “soft” mute with the volume ramping down to mute in 4096 samples from the maximum volume setting at the internal processing rate (~96 kHz).

A “hard mute” can be obtained by commanding a value of all 1’s (255) to any channel volume register or the master volume register. When volume offsets are provided via the master volume register any channel that whose total volume is less than -80 dB is muted.

All changes in volume take place at zero-crossings when ZCE = 1 (configuration register F) on a per channel basis as this creates the smoothest possible volume transitions. When ZCE = 0, volume updates occur immediately.

Table 17. Master volume offset as a function of MV[7:0]

MV[7:0]	Volume offset from channel value
00000000 (0x00)	0 dB
00000001 (0x01)	-0.5 dB
00000010 (0x02)	-1 dB
...	...
01001100 (0x4C)	-38 dB
...	...
11111110 (0xFE)	-127.5 dB
11111111 (0xFF)	Hard master mute

Table 18. Channel volume as a function of CxV[7:0]

CxV[7:0]	Volume
00000000 (0x00)	+48 dB
00000001 (0x01)	+47.5 dB
00000010 (0x02)	+47 dB
...	...
01011111 (0x5F)	+0.5 dB
01100000 (0x60)	0 dB
01100001 (0x61)	-0.5 dB

Table 18. Channel volume as a function of CxV[7:0] (continued)

CxV[7:0]	Volume
...	...
11010111 (0xD7)	-59.5 dB
11011000 (0xD8)	-60 dB
11011001 (0xD9)	-61 dB
11011010 (0xDA)	-62 dB
...	...
11101100 (0xEC)	-80 dB
11101101 (0xED)	Hard channel mute
...	...
11111111 (0xFF)	Hard channel mute

www.datasheet4u.com

6.8 Auto mode registers (addr 0x0B and 0x0C)

6.8.1 Automode register 1 (address 0x0B)

AMGC[1:0], in conjunction with AMGC[3:2] defined in register 0x31, defines anti-clipping and DRC presets. Using AMGC[3:0] bits, attack and release thresholds and rates are automatically configured to properly fit application specific configuration.

D7	D6	D5	D4	D3	D2	D1	D0
Reserved		AMGC1	AMGC2	Reserved			
		0	0				

Table 19. AutoMode gain compression/limiters selection

AMGC[1:0]	Mode
00	User programmable GC
01	AC no clipping 2.1
10	AC limited clipping (10%) 2.1
11	DRC nighttime listening mode 2.1

6.8.2 AutoMode register 2 (address 0x0C)

D7	D6	D5	D4	D3	D2	D1	D0
XO3	XO2	XO1	XO0	AMAM2	AMAM1	AMAM0	AMAME
0	0	0	0	0	0	0	0

6.8.3 AM interference frequency switching

www.datasheet4u.com

Bit	R/W	RST	Name	Description
0	R/W	0	AMAME	AutoMode AM Enable 0: Switching frequency determined by PWMS setting 1: Switching frequency determined by AMAM settings

Table 20. AutoMode AM switching frequency selection

AMAM[2:0]	48 kHz/96 kHz Input Fs	44.1 kHz/88.2 kHz Input Fs
000	0.535 MHz - 0.720 MHz	0.535 MHz - 0.670 MHz
001	0.721 MHz - 0.900 MHz	0.671 MHz - 0.800 MHz
010	0.901 MHz - 1.100 MHz	0.801 MHz - 1.000 MHz
011	1.101 MHz - 1.300 MHz	1.001 MHz - 1.180 MHz
100	1.301 MHz - 1.480 MHz	1.181 MHz - 1.340 MHz
101	1.481 MHz - 1.600 MHz	1.341 MHz - 1.500 MHz
110	1.601 MHz - 1.700 MHz	1.501 MHz - 1.700 MHz

6.8.4 Bass management crossover

Bit	R/W	RST	Name	Description
4	R/W	0	XO0	Selects the bass-management crossover frequency. A 1st-order hi-pass filter (channels 1 and 2) or a 2nd-order lo-pass filter (channel 3) at the selected frequency is performed.
5	R/W	0	XO1	
6	R/W	0	XO2	
7	R/W	0	XO3	

Table 21. Bass management crossover frequency

XO[3:0]	Crossover frequency
0000	User-Defined
0001	80 Hz
0010	100 Hz
0011	120 Hz
0100	140 Hz
0101	160 Hz
0110	180 Hz
0111	200 Hz
1000	220 Hz
1001	240 Hz
1010	260 Hz
1011	280 Hz

Table 21. Bass management crossover frequency (continued)

XO[3:0]	Crossover frequency
1100	300 Hz
1101	320 Hz
1110	340 Hz
1111	360 Hz

www.datasheet4u.com

6.9 Channel configuration registers (addr 0x0E to 0x10)

D7	D6	D5	D4	D3	D2	D1	D0
C1OM1	C1OM0	C1LS1	C1LS0	C1BO	C1VPB	C1EQBP	C1TCB
0	0	0	0	0	0	0	0

D7	D6	D5	D4	D3	D2	D1	D0
C2OM1	C2OM0	C2LS1	C2LS0	C2BO	C2VPB	C2EQBP	C2TCB
0	1	0	0	0	0	0	0

D7	D6	D5	D4	D3	D2	D1	D0
C3OM1	C3OM0	C3LS1	C3LS0	C3BO	C3VPB	Reserved	
1	0	0	0	0	0		

6.9.1 Tone control bypass

Tone control (bass/treble) can be bypassed on a per channel basis for channels 1 and 2.

CxTCB:

0: Perform tone control on channel X (normal operation)

1: Bypass tone control on channel X

6.9.2 EQ bypass

EQ control can be bypassed on a per channel basis for channels 1 and 2. If EQ control is bypassed on a given channel the prescale and all filters (high-pass, biquads, de-emphasis, bass, treble in any combination) are bypassed for that channel.

CxEQBP:

0: Perform EQ on channel X - normal operation

1: Bypass EQ on channel X

6.9.3 Volume bypass

Each channel contains an individual channel volume bypass. If a particular channel has volume bypassed via the CxVBP = 1 register then only the channel volume setting for that particular channel affects the volume setting, the master volume setting will not affect that channel.

www.datasheet4u.com

6.9.4 Binary output enable registers

Each individual channel output can be set to output a binary PWM stream. In this mode output A of a channel is considered the positive output and output B is negative inverse.

CxBO:

0: DDX tri-state output - normal operation

1: Binary output

6.9.5 Limiter select

Limiter selection can be made on a per-channel basis according to the channel limiter select bits.

Table 22. Channel limiter mapping as a function of CxLS bits

CxLS[1,0]	Channel limiter mapping
00	Channel has limiting disabled
01	Channel is mapped to limiter #1
10	Channel is mapped to limiter #2

6.9.6 Output mapping

Output mapping can be performed on a per channel basis according to the CxOM channel output mapping bits. Each input into the output configuration engine can receive data from any of the three processing channel outputs.

Table 23. Channel output mapping as a function of CxOM bits

CxOM[1,0]	Channel x output source from
00	Channel1
01	Channel 2
10	Channel 3

6.10 Tone control register (addr 0x11)

6.10.1 Tone control

www.datasheet4u.com

D7	D6	D5	D4	D3	D2	D1	D0
TTC3	TTC2	TTC1	TTC0	BTC3	BTC2	BTC1	BTC0
0	1	1	1	0	1	1	1

Table 24. Tone control boost/cut as a function of BTC and TTC bits

BTC[3:0]/TTC[3:0]	Boost/Cut
0000	-12 dB
0001	-12 dB
...	...
0111	-4 dB
0110	-2 dB
0111	0 dB
1000	+2 dB
1001	+4 dB
...	...
1101	+12 dB
1110	+12 dB
1111	+12 dB

6.11 Dynamics control registers (addr 0x12 to 0x15)

6.11.1 Limiter 1 attack/release rate

D7	D6	D5	D4	D3	D2	D1	D0
L1A3	L1A2	L1A1	L1A0	L1R3	L1R2	L1R1	L1R0
0	1	1	0	1	0	1	0

6.11.2 Limiter 1 attack/release threshold

D7	D6	D5	D4	D3	D2	D1	D0
L1AT3	L1AT2	L1AT1	L1AT0	L1RT3	L1RT2	L1RT1	L1RT0
0	1	1	0	1	0	0	1

6.11.3 Limiter 2 attack/release rate

D7	D6	D5	D4	D3	D2	D1	D0
L2A3	L2A2	L2A1	L2A0	L2R3	L2R2	L2R1	L2R0
0	1	1	0	1	0	1	0

6.11.4 Limiter 2 attack/release threshold

www.datasheet4u.com

D7	D6	D5	D4	D3	D2	D1	D0
L2AT3	L2AT2	L2AT1	L2AT0	L2RT3	L2RT2	L2RT1	L2RT0
0	1	1	0	1	0	0	1

The STA335BWS includes two independent limiter blocks. The purpose of the limiters is to automatically reduce the dynamic range of a recording to prevent the outputs from clipping in anti-clipping mode or to actively reduce the dynamic range for a better listening environment such as a night-time listening mode which is often needed for DVDs. The two modes are selected via the DRC bit in Configuration Register F, bit 0 address 0x05. Each channel can be mapped to either limiter or not mapped, meaning that channel will clip when 0dBFS is exceeded. Each limiter looks at the present value of each channel that is mapped to it, selects the maximum absolute value of all these channels, performs the limiting algorithm on that value, and then if needed adjusts the gain of the mapped channels in unison.

The limiter attack thresholds are determined by the LxAT registers. It is recommended in anti-clipping mode to set this to 0dBFS, which corresponds to the maximum unclipped output power of a DDX amplifier. Since gain can be added digitally within STA335BWS it is possible to exceed 0dBFS or any other LxAT setting, when this occurs, the limiter, when active, automatically starts reducing the gain. The rate at which the gain is reduced when the attack threshold is exceeded is dependent upon the attack rate register setting for that limiter. The gain reduction occurs on a peak-detect algorithm.

The release of limiter, when the gain is again increased, is dependent on a RMS-detect algorithm. The output of the volume/limiter block is passed through a RMS filter. The output of this filter is compared to the release threshold, determined by the Release Threshold register. When the RMS filter output falls below the release threshold, the gain is again increased at a rate dependent upon the Release Rate register. The gain can never be increased past it's set value and therefore the release only occurs if the limiter has already reduced the gain. The release threshold value can be used to set what is effectively a minimum dynamic range, this is helpful as over-limiting can reduce the dynamic range to virtually zero and cause program material to sound "lifeless".

In AC mode, the attack and release thresholds are set relative to full-scale. In DRC mode, the attack threshold is set relative to the maximum volume setting of the channels mapped to that limiter and the release threshold is set relative to the maximum volume setting plus the attack threshold.

Figure 16. Basic limiter and volume flow diagram

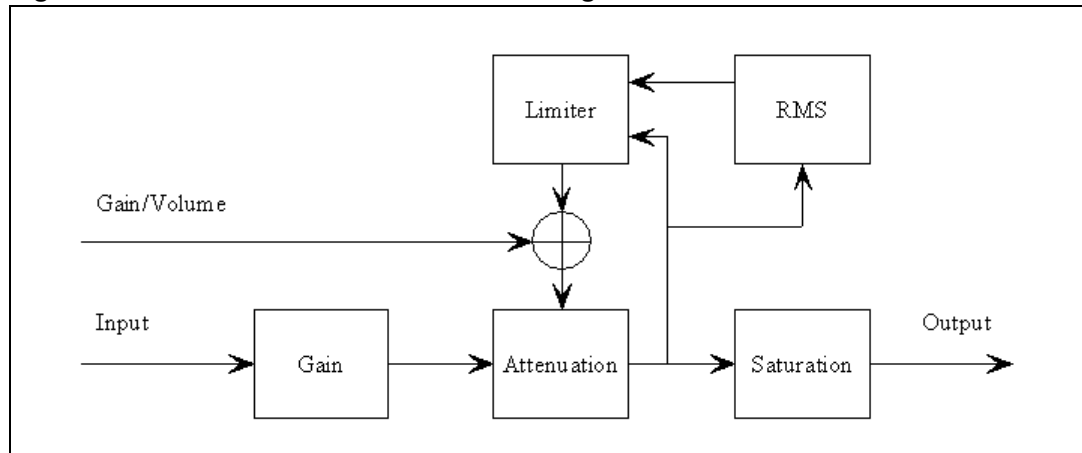

www.datasheet4u.com

Table 25. Limiter attack rate as a function of LxA bits

LxA[3:0]	Attack rate dB/ms	
0000	3.1584	Fast ↓ Slow
0001	2.7072	
0010	2.2560	
0011	1.8048	
0100	1.3536	
0101	0.9024	
0110	0.4512	
0111	0.2256	
1000	0.1504	
1001	0.1123	
1010	0.0902	
1011	0.0752	
1100	0.0645	
1101	0.0564	
1110	0.0501	
1111	0.0451	

Table 26. Limiter release rate as a function of LxR bits

LxR[3:0]	Release rate dB/ms	
0000	0.5116	Fast ↓ Slow
0001	0.1370	
0010	0.0744	
0011	0.0499	
0100	0.0360	
0101	0.0299	
0110	0.0264	
0111	0.0208	
1000	0.0198	
1001	0.0172	
1010	0.0147	
1011	0.0137	
1100	0.0134	
1101	0.0117	
1110	0.0110	
1111	0.0104	

Anti-clipping mode

Table 27. Limiter attack threshold as a function of LxAT bits (AC-mode)

LxAT[3:0]	AC (dB relative to FS)
0000	-12
0001	-10
0010	-8
0011	-6
0100	-4
0101	-2
0110	0
0111	+2
1000	+3
1001	+4
1010	+5
1011	+6
1100	+7
1101	+8
1110	+9
1111	+10

Table 28. Limiter release threshold as a function of LxRT bits (AC-mode)

LxRT[3:0]	AC (dB relative to FS)
0000	$-\infty$
0001	-29 dB
0010	-20 dB
0011	-16 dB
0100	-14 dB
0101	-12 dB
0110	-10 dB
0111	-8 dB
1000	-7 dB
1001	-6 dB
1010	-5 dB
1011	-4 dB
1100	-3 dB
1101	-2 dB
1110	-1 dB
1111	-0 dB

www.datasheet4u.com

Dynamic range compression mode

www.datasheet4u.com

Table 29. Limiter attack threshold as a function of LxAT bits (DRC-Mode)

LxAT[3:0]	DRC (dB relative to Volume)
0000	-31
0001	-29
0010	-27
0011	-25
0100	-23
0101	-21
0110	-19
0111	-17
1000	-16
1001	-15
1010	-14
1011	-13
1100	-12
1101	-10
1110	-7
1111	-4

Table 30. Limiter release threshold as a function of LxRT bits (DRC-Mode)

LxRT[3:0]	DRC (db relative to Volume + LxAT)
0000	-∞
0001	-38 dB
0010	-36 dB
0011	-33 dB
0100	-31 dB
0101	-30 dB
0110	-28 dB
0111	-26 dB
1000	-24 dB
1001	-22 dB
1010	-20 dB
1011	-18 dB
1100	-15 dB
1101	-12 dB
1110	-9 dB
1111	-6 dB

6.12 User-defined coefficient control registers (addr 0x16 to 0x26)

6.12.1 Coefficient address register

D7	D6	D5	D4	D3	D2	D1	D0
Reserved		CFA5	CFA4	CFA3	CFA2	CFA1	CFA0
		0	0	0	0	0	0

6.12.2 Coefficient b1 data register bits 23:16

D7	D6	D5	D4	D3	D2	D1	D0
C1B23	C1B22	C1B21	C1B20	C1B19	C1B18	C1B17	C1B16
0	0	0	0	0	0	0	0



6.12.3 Coefficient b1 data register bits 15:8

www.datasheet4u.com

D7	D6	D5	D4	D3	D2	D1	D0
C1B15	C1B14	C1B13	C1B12	C1B11	C1B10	C1B9	C1B8
0	0	0	0	0	0	0	0

6.12.4 Coefficient b1 data register bits 7:0

D7	D6	D5	D4	D3	D2	D1	D0
C1B7	C1B6	C1B5	C1B4	C1B3	C1B2	C1B1	C1B0
0	0	0	0	0	0	0	0

6.12.5 Coefficient b2 data register bits 23:16

D7	D6	D5	D4	D3	D2	D1	D0
C2B23	C2B22	C2B21	C2B20	C2B19	C2B18	C2B17	C2B16
0	0	0	0	0	0	0	0

6.12.6 Coefficient b2 data register bits 15:8

D7	D6	D5	D4	D3	D2	D1	D0
C2B15	C2B14	C2B13	C2B12	C2B11	C2B10	C2B9	C2B8
0	0	0	0	0	0	0	0

6.12.7 Coefficient b2 data register bits 7:0

D7	D6	D5	D4	D3	D2	D1	D0
C2B7	C2B6	C2B5	C2B4	C2B3	C2B2	C2B1	C2B0
0	0	0	0	0	0	0	0

6.12.8 Coefficient a1 data register bits 23:16

D7	D6	D5	D4	D3	D2	D1	D0
C1B23	C1B22	C1B21	C1B20	C1B19	C1B18	C1B17	C1B16
0	0	0	0	0	0	0	0

6.12.9 Coefficient a1 data register bits 15:8

D7	D6	D5	D4	D3	D2	D1	D0
C3B15	C3B14	C3B13	C3B12	C3B11	C3B10	C3B9	C3B8
0	0	0	0	0	0	0	0

6.12.10 Coefficient a1 data register bits 7:0

D7	D6	D5	D4	D3	D2	D1	D0
C3B7	C3B6	C3B5	C3B4	C3B3	C3B2	C3B1	C3B0
0	0	0	0	0	0	0	0

www.datasheet4u.com

6.12.11 Coefficient a2 data register bits 23:16

D7	D6	D5	D4	D3	D2	D1	D0
C4B23	C4B22	C4B21	C4B20	C4B19	C4B18	C4B17	C4B16
0	0	0	0	0	0	0	0

6.12.12 Coefficient a2 data register bits 15:8

D7	D6	D5	D4	D3	D2	D1	D0
C4B15	C4B14	C4B13	C4B12	C4B11	C4B10	C4B9	C4B8
0	0	0	0	0	0	0	0

6.12.13 Coefficient a2 data register bits 7:0

D7	D6	D5	D4	D3	D2	D1	D0
C4B7	C4B6	C4B5	C4B4	C4B3	C4B2	C4B1	C4B0
0	0	0	0	0	0	0	0

6.12.14 Coefficient b0 data register bits 23:16

D7	D6	D5	D4	D3	D2	D1	D0
C5B23	C5B22	C5B21	C5B20	C5B19	C5B18	C5B17	C5B16
0	0	0	0	0	0	0	0

6.12.15 Coefficient b0 data register bits 15:8

D7	D6	D5	D4	D3	D2	D1	D0
C5B15	C5B14	C5B13	C5B12	C5B11	C5B10	C5B9	C5B8
0	0	0	0	0	0	0	0

6.12.16 Coefficient b0 data register bits 7:0

D7	D6	D5	D4	D3	D2	D1	D0
C5B7	C5B6	C5B5	C5B4	C5B3	C5B2	C5B1	C5B0
0	0	0	0	0	0	0	0

6.12.17 Coefficient write/read control register

www.datasheet4u.com

D7	D6	D5	D4	D3	D2	D1	D0
Reserved				RA	R1	WA	W1
				0	0	0	0

Coefficients for user-defined EQ, Mixing, Scaling, and Bass Management are handled internally in the STA335BWS via RAM. Access to this RAM is available to the user via an I²C register interface. A collection of I²C registers are dedicated to this function. One contains a coefficient base address, five sets of three store the values of the 24-bit coefficients to be written or that were read, and one contains bits used to control the write/read of the coefficient(s) to/from RAM.

Three different RAM banks are embedded in STA335BWS. The 3 banks are managed in paging mode using EQCFG register bits. They can be used to store different EQ settings. For speaker frequency compensation, a sampling frequency independent EQ must be implemented. Computing 3 different coefficients set for 32 kHz, 44.1kHz, 48 kHz and downloading them in the 3 RAM banks, it is possible to select the suitable RAM block depending from the incoming frequency with a simple I²C write operation on register 0x31.

For example, in case of different input sources (different sampling rates), the 3 different set of coefficients can be downloaded once at the start up, and during the normal play it is possible to switch among the 3 RAM blocks allowing a faster operation, without any additional download from the microcontroller.

To write the coefficients in a particular RAM bank, this bank must be selected first writing bit 0 and bit 1 in register 0x31. Then the below write procedure can be used.

Note that as soon as a RAM bank is selected, the EQ settings will be automatically switched to the coefficients stored in the active RAM block.

Note: The read and write operation on RAM coefficients works only if LRCKI (pin 29) is switching.

Reading a coefficient from RAM

1. Select the RAM block with register 0x31 bit1, bit0.
2. Write 6-bits of address to I²C register 0x16.
3. Write 1 to R1 bit in I²C address 0x26.
4. Read top 8-bits of coefficient in I²C address 0x17.
5. Read middle 8-bits of coefficient in I²C address 0x18.
6. Read bottom 8-bits of coefficient in I²C address 0x19.

Reading a set of coefficients from RAM

1. Select the RAM block with register 0x31 bit1, bit0.
2. Write 6-bits of address to I²C register 0x16.
3. Write 1 to RA bit in I²C address 0x26.
4. Read top 8-bits of coefficient in I²C address 0x17.
5. Read middle 8-bits of coefficient in I²C address 0x18.
6. Read bottom 8-bits of coefficient in I²C address 0x19.
7. Read top 8-bits of coefficient b2 in I²C address 0x1A.
8. Read middle 8-bits of coefficient b2 in I²C address 0x1B.

9. Read bottom 8-bits of coefficient b2 in I²C address 0x1C.
10. Read top 8-bits of coefficient a1 in I²C address 0x1D.
11. Read middle 8-bits of coefficient a1 in I²C address 0x1E.
12. Read bottom 8-bits of coefficient a1 in I²C address 0x1F.
13. Read top 8-bits of coefficient a2 in I²C address 0x20.
14. Read middle 8-bits of coefficient a2 in I²C address 0x21.
15. Read bottom 8-bits of coefficient a2 in I²C address 0x22.
16. Read top 8-bits of coefficient b0 in I²C address 0x23.
17. Read middle 8-bits of coefficient b0 in I²C address 0x24.
18. Read bottom 8-bits of coefficient b0 in I²C address 0x25.

Writing a single coefficient to RAM

1. Select the RAM block with register 0x31 bit1, bit0.
2. Write 6-bits of address to I²C register 0x16.
3. Write top 8-bits of coefficient in I²C address 0x17.
4. Write middle 8-bits of coefficient in I²C address 0x18.
5. Write bottom 8-bits of coefficient in I²C address 0x19.
6. Write 1 to W1 bit in I²C address 0x26.

Writing a set of coefficients to RAM

1. Select the RAM block with register 0x31 bit1, bit0.
2. Write 6-bits of starting address to I²C register 0x16.
3. Write top 8-bits of coefficient b1 in I²C address 0x17.
4. Write middle 8-bits of coefficient b1 in I²C address 0x18.
5. Write bottom 8-bits of coefficient b1 in I²C address 0x19.
6. Write top 8-bits of coefficient b2 in I²C address 0x1A.
7. Write middle 8-bits of coefficient b2 in I²C address 0x1B.
8. Write bottom 8-bits of coefficient b2 in I²C address 0x1C.
9. Write top 8-bits of coefficient a1 in I²C address 0x1D.
10. Write middle 8-bits of coefficient a1 in I²C address 0x1E.
11. Write bottom 8-bits of coefficient a1 in I²C address 0x1F.
12. Write top 8-bits of coefficient a2 in I²C address 0x20.
13. Write middle 8-bits of coefficient a2 in I²C address 0x21.
14. Write bottom 8-bits of coefficient a2 in I²C address 0x22.
15. Write top 8-bits of coefficient b0 in I²C address 0x23.
16. Write middle 8-bits of coefficient b0 in I²C address 0x24.
17. Write bottom 8-bits of coefficient b0 in I²C address 0x25.
18. Write 1 to WA bit in I²C address 0x26.

The mechanism for writing a set of coefficients to RAM provides a method of updating the five coefficients corresponding to a given biquad (filter) simultaneously to avoid possible unpleasant acoustic side-effects. When using this technique, the 6-bit address specifies the address of the biquad b1 coefficient (for example, 0, 5, 10, 20, 35 decimal), and the

STA335BWS generates the RAM addresses as offsets from this base value to write the complete set of coefficient data.

6.12.18 User-defined EQ

www.datasheet4u.com

The STA335BWS provides the ability to specify four EQ filters (biquads) per each of the two input channels. The biquads use the following equation:

$$Y[n] = 2(b_0/2)X[n] + 2(b_1/2)X[n-1] + b_2X[n-2] - 2(a_1/2)Y[n-1] - a_2Y[n-2]$$

$$= b_0X[n] + b_1X[n-1] + b_2X[n-2] - a_1Y[n-1] - a_2Y[n-2]$$

where $Y[n]$ represents the output and $X[n]$ represents the input. Multipliers are 24-bit signed fractional multipliers, with coefficient values in the range of 0x800000 (-1) to 0x7FFFFFFF (0.9999998808).

Coefficients stored in the user-defined coefficient RAM are referenced as follows:

$$\begin{aligned} CxHy0 &= b_1/2 \\ CxHy1 &= b_2 \\ CxHy2 &= -a_1/2 \\ CxHy3 &= -a_2 \\ CxHy4 &= b_0/2 \end{aligned}$$

where x represents the channel and the y the biquad number. For example C2H41 is the b_2 coefficient in the fourth biquad for channel 2.

Additionally, the STA335BWS allows specification of a high-pass filter (processing channels 1 and 2) and a lo-pass filter (processing channel 3) to be used for bass-management crossover when the XO setting is 000 (user-defined). Both of these filters when defined by the user (rather than using the preset crossover filters) are second order filters that use the biquad equation noted above. They are loaded into the C12H0-4 and C3Hy0-4 areas of RAM noted in [Table 31](#).

By default, all user-defined filters are pass-through where all coefficients are set to 0, except the $b_0/2$ coefficient which is set to 0x400000 (representing 0.5)

6.12.19 Pre-scale

The STA335BWS provides a multiplication for each input channel for the purpose of scaling the input prior to EQ. This pre-EQ scaling is accomplished by using a 24-bit signed fractional multiplier, with 0x800000 = -1 and 0x7FFFFFFF = 0.9999998808. The scale factor for this multiply is loaded into RAM using the same I²C registers as the biquad coefficients and the bass-management. All channels can use the channel 1 pre-scale factor by setting the Biquad link bit. By default, all pre-scale factors are set to 0x7FFFFFFF.

6.12.20 Post-scale

The STA335BWS provides one additional multiplication after the last interpolation stage and the distortion compensation on each channel. This post-scaling is accomplished by using a 24-bit signed fractional multiplier, with 0x800000 = -1 and 0x7FFFFFFF = 0.9999998808. The scale factor for this multiply is loaded into RAM using the same I²C registers as the biquad coefficients and the bass-management. This post-scale factor can be used in conjunction with an ADC equipped micro-controller to perform power-supply error correction. All channels can use the channel 1 post-scale factor by setting the post-scale link bit. By default, all post-scale factors are set to 0x7FFFFFFF. When line output is being used, channel 3 post-scale affects both channels 3 and 4.

6.12.21 Over-current post-scale

The STA335BWS provides a simple mechanism for reacting to over-current detection in the power-block. When the OCWARN input is asserted, the over-current post-scale value is used in place of the normal post-scale value to provide output attenuation on all channels. The default setting provides 3 dB of output attenuation when OCWARN is asserted.

www.datasheet4u.com

The amount of attenuation to be applied in this situation can be adjusted by modifying the over-current post-scale value. As with the normal post-scale, this scaling value is a 24-bit signed fractional multiplier, with 0x800000 = -1 and 0x7FFFFFFF = 0.9999998808. By default, the over-current post-scale factor is set to 0x5A9DF7. Once the over-current attenuation is applied, it remains until the device is reset.

Table 31. RAM block for biquads, mixing, scaling and bass management

Index (Decimal)	Index (Hex)		Coefficient	Default
0	0x00	Channel 1, Biquad 1	C1H10(b1/2)	0x000000
1	0x01		C1H11(b2)	0x000000
2	0x02		C1H12(a1/2)	0x000000
3	0x03		C1H13(a2)	0x000000
4	0x04		C1H14(b0/2)	0x400000
5	0x05	Channel 1, Biquad 2	C1H20	0x000000
...
19	0x13	Channel 1, Biquad 4	C1H44	0x400000
20	0x14	Channel 2, Biquad 1	C2H10	0x000000
21	0x15		C2H11	0x000000
...
39	0x27	Channel 2, Biquad 4	C2H44	0x400000
40	0x28	Channel 1/2 - Biquad 5 for XO = 000 Hi-pass 2 nd Order filter for XO≠000	C12H0(b1/2)	0x000000
41	0x29		C12H1(b2)	0x000000
42	0x2A		C12H2(a1/2)	0x000000
43	0x2B		C12H3(a2)	0x000000
44	0x2C		C12H4(b0/2)	0x400000
45	0x2D	Channel 3 - Biquad for XO = 000 Low-pass 2 nd Order filter for XO≠000	C3H0(b1/2)	0x000000
46	0x2E		C3H1(b2)	0x000000
47	0x2F		C3H2(a1/2)	0x000000
48	0x30		C3H3(a2)	0x000000
49	0x31		C3H4(b0/2)	0x400000
50	0x32	Channel 1, Pre-Scale	C1PreS	0x7FFFFFFF
51	0x33	Channel 2, Pre-Scale	C2PreS	0x7FFFFFFF
52	0x34	Channel 1, Post-Scale	C1PstS	0x7FFFFFFF
53	0x35	Channel 2, Post-Scale	C2PstS	0x7FFFFFFF

Table 31. RAM block for biquads, mixing, scaling and bass management

Index (Decimal)	Index (Hex)		Coefficient	Default
54	0x36	Channel 3, Post-scale	C3PstS	0x7FFFFFFF
55	0x37	TWARN/OC - Limit	TWOCL	0x5A9DF7
56	0x38	Channel 1, Mix 1	C1MX1	0x7FFFFFFF
57	0x39	Channel 1, Mix 2	C1MX2	0x000000
58	0x3A	Channel 2, Mix 1	C2MX1	0x000000
59	0x3B	Channel 2, Mix 2	C2MX2	0x7FFFFFFF
60	0x3C	Channel 3, Mix 1	C3MX1	0x400000
61	0x3D	Channel 3, Mix 2	C3MX2	0x400000
62	0x3E	Unused		
63	0x3F	Unused		

www.datasheet4u.com

6.13 Variable max power correction registers (addr 0x27 to 0x28)

MPCC bits determine the 16 MSBs of the MPC compensation coefficient. This coefficient is used in place of the default coefficient when MPCV = 1.

D7	D6	D5	D4	D3	D2	D1	D0
MPCC15	MPCC14	MPCC13	MPCC12	MPCC11	MPCC10	MPCC9	MPCC8
0	0	0	1	1	0	1	0

D7	D6	D5	D4	D3	D2	D1	D0
MPCC7	MPCC6	MPCC5	MPCC4	MPCC3	MPCC2	MPCC1	MPCC0
1	1	0	0	0	0	0	0

6.14 Variable distortion compensation registers (addr 0x29 to 0x2A)

DCC bits determine the 16 MSBs of the distortion compensation coefficient. This coefficient is used in place of the default coefficient when DCCV = 1.

D7	D6	D5	D4	D3	D2	D1	D0
DCC15	DCC14	DCC13	DCC12	DCC11	DCC10	DCC9	DCC8
1	1	1	1	0	0	1	1

D7	D6	D5	D4	D3	D2	D1	D0
DCC7	DCC6	DCC5	DCC4	DCC3	DCC2	DCC1	DCC0
0	0	1	1	0	0	1	1

6.15 Fault detect recovery constant registers (addr 0x2B to 0x2C)

FDRC bits specify the 16-bit fault detect recovery time delay. When FAULT is asserted, the TRISTATE output is immediately asserted low and held low for the time period specified by this constant. A constant value of 0x0001 in this register is ~0.083 ms. The default value of 0x000C specifies ~0.1 ms.

www.datasheet4u.com

D7	D6	D5	D4	D3	D2	D1	D0
FDRC15	FDRC14	FDRC13	FDRC12	FDRC11	FDRC10	FDRC9	FDRC8
0	0	0	0	0	0	0	0

D7	D6	D5	D4	D3	D2	D1	D0
FDRC7	FDRC6	FDRC5	FDRC4	FDRC3	FDRC2	FDRC1	FDRC0
0	0	0	0	1	1	0	0

6.16 Device status register (addr 0x2D)

D7	D6	D5	D4	D3	D2	D1	D0
PLLUL	FAULT	UVFAULT	OVFAULT	OCFAULT	OCWARN	TFAULT	TWARN

This read-only register provides fault and thermal-warning status information from the power control block. Logic value 1 for faults or warning means normal state. Logic 0 means a fault or warning detected on power bridge. The PLLUL = 1 means that the PLL is not locked.

- PLLUL: 0 = PLL locked, 1 = PLL not locked.
- FAULT: 0 = fault detected on power bridge, 1 = normal operation
- UVFAULT: 0 = VCCxX internally detected < undervoltage threshold.
- OVFAULT: 0 = VCCxX internally detected > overvoltage threshold.
- OCFAULT: 0 = overcurrent fault detected
- OCWARN: 0 = overcurrent warning.
- TFAULT: 0 = thermal fault. Junction temperature over limit detection.
- TWARN: 0 = thermal warning. The junction temperature is close to the fault condition.

6.17 EQ coefficients and DRC configuration register (addr 0x31)

www.datasheet4u.com

D7	D6	D5	D4	D3	D2	D1	D0
XOB	Reserved		AMGC[3]	AMGC[2]	reserved	SEL1	SEL0
0	0	0	0	0	0	0	0

Table 32. SEL bitfield description

SEL[1,0]	EQ RAM bank selected
00/11	Bank 0 activated
01	Bank 1 activated
10	Bank 2 activated

Table 33. AMGC bitfield description

AMGC[3,2]	Anti-clipping and DRC preset selected
00	DRC/Anti-clipping (default)
01	DRC/Anti-clipping
10/11	Reserved, do not use

AC0, AC1, AC2 settings are designed for loudspeaker protection function, limiting at the minimum any audio artefact introduced by typical anti-clipping/DRC algorithms. More detailed information can be retrieved in the “Configurable output power rate using STA335BW” and “STA335BWS vs STA335BW” application notes.

Table 34. AMGC bitfield description

AMGC[1:0]	Mode
00	AC0, stereo anti-clipping 0dB limiter
01	AC1, stereo anti-clipping +1.25dB limiter
10	AC2, stereo anti-clipping +2dB limiter
11	reserved do not use

Bit XOB can be used to bypass the crossover filters. Logic 1 means that the function is not active. In this case, high pass crossover filter works as a pass through on the data path (b0 = 1, all the other coefficients at logic 0) while the low pass filter is configured to have zero signal on channel 3 data processing (all the coefficients are at logic 0).

7 Application

7.1 Application schematic and power supplies

www.datasheet4u.com

Figure 17 shows a circuit diagram of a typical application for STA335BWS. Particular care has to be given to the layout of the PCB, especially the power supplies. The 3.3 Ω resistors on the digital supplies (VDD_DIG) have to be placed as close as possible to the device. This helps to prevent unwanted oscillation on the digital portion of the device due to inductive tracks of the PCB. This same rule is also be applied to all the decoupling capacitors in order to limit any kind of spikes on all the supplies.

Figure 17. Application schematic

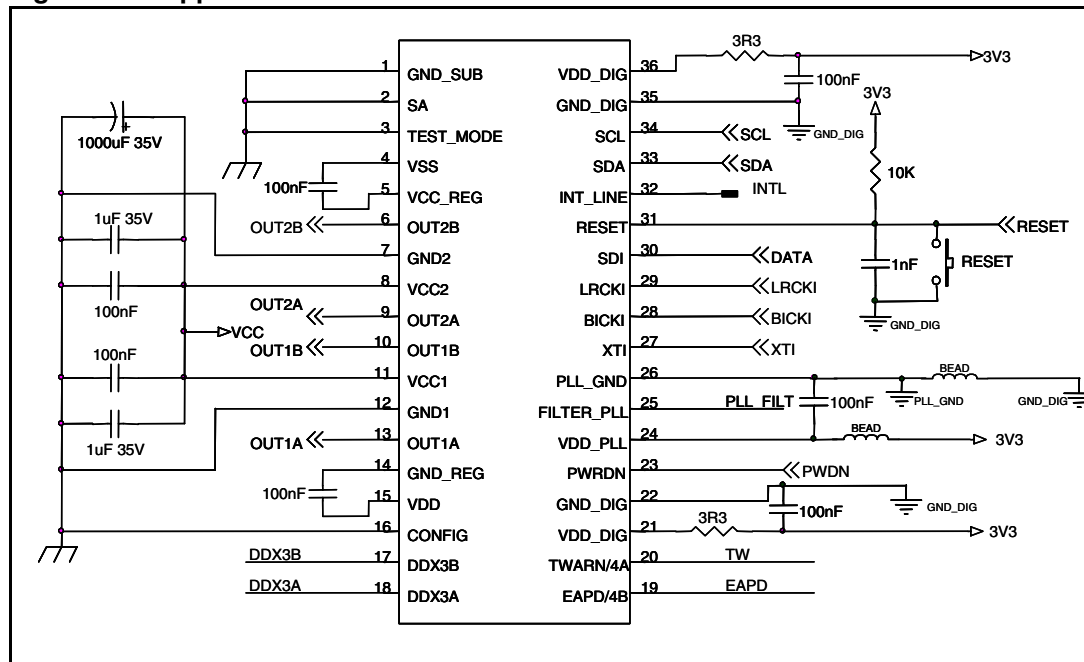

7.2 PLL filter schematic

It is recommended to use the below scheme and values for the PLL loop filter to achieve the best performances from the device in general application. Please be noted that the ground of this filter scheme has to be connected to the ground of the PLL without any resistive path. Concerning the component values, please take into account that the greater is the filter bandwidth, the less is the lock time but the higher is the PLL output jitter.

Figure 18. PLL application scheme

www.datasheet4u.com

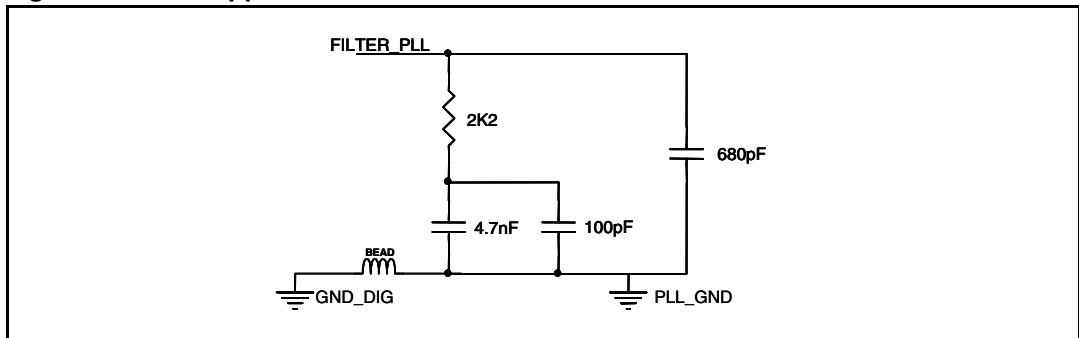

7.3 Typical output configuration

Here after the typical output configuration used for BTL stereo mode. Please refer to the application note for all the other possible output configuration recommended schematics.

Figure 19. Output configuration for stereo BTL mode

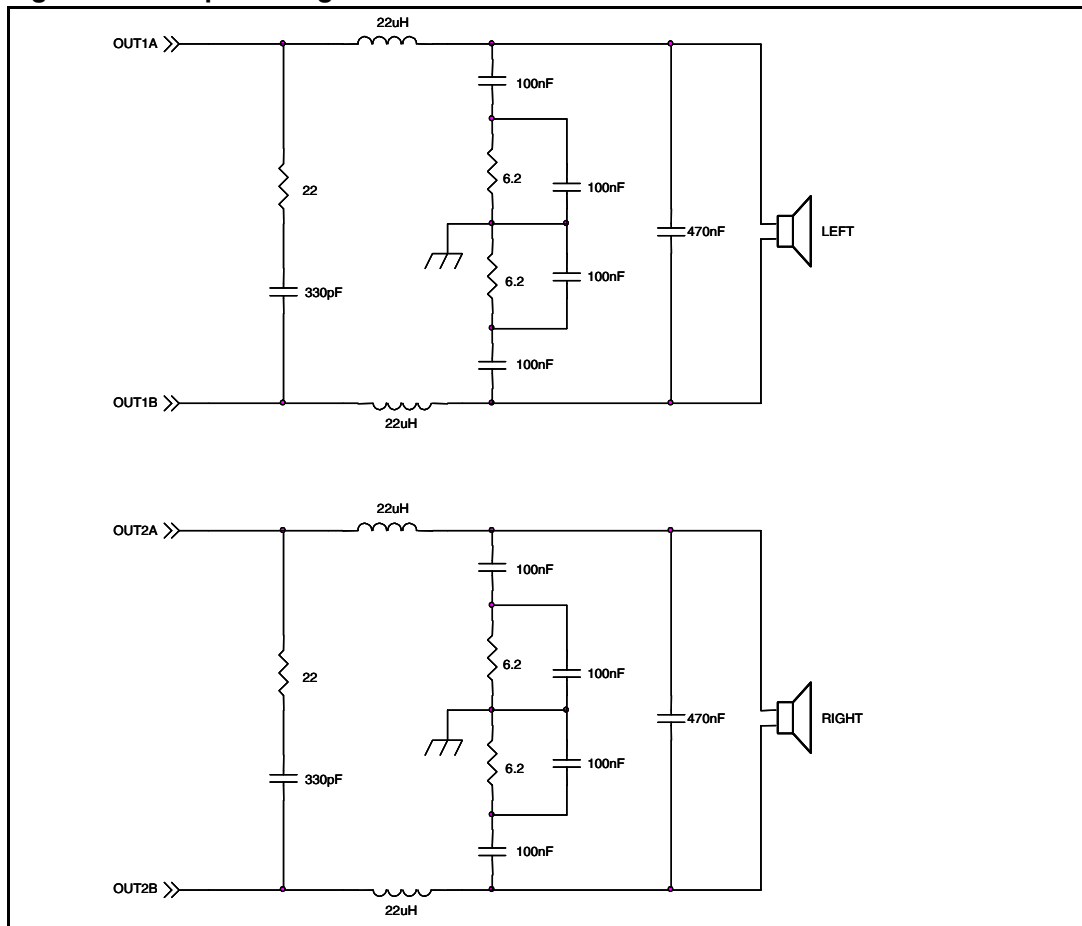

8 Package thermal characteristics

www.datasheet4u.com

Using a triple-layer PCB the thermal resistance (junction to ambient) with a center copper ground area of 3 x 3 cm² and with 16 via holes (see [Figure 20](#)) is 24° C/W in natural air convection.

The dissipated power within the device depends primarily on the supply voltage, load impedance and output modulation level.

The max estimated dissipated power for the STA335BWS is:

$$2 \times 20 \text{ W @ } 8 \Omega, 18 \text{ V} \quad P_d \text{ max } \sim 4 \text{ W}$$

$$2 \times 10 \text{ W} + 1 \times 20 \text{ W @ } 4 \Omega, 8 \Omega, 18 \text{ V} \quad P_d \text{ max } < 5 \text{ W}$$

Figure 20. Triple-layer PCB with copper ground area and 16 via holes

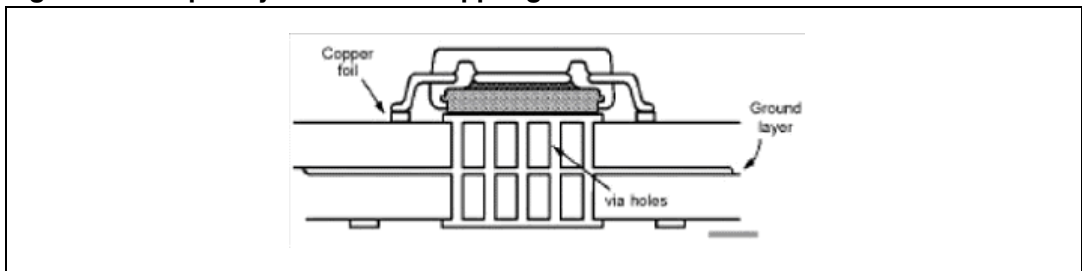

[Figure 21](#) shows the power derating curves for the PowerSSO-36 package on a board with two different sizes of copper layers.

Figure 21. PowerSSO-36 power derating curve

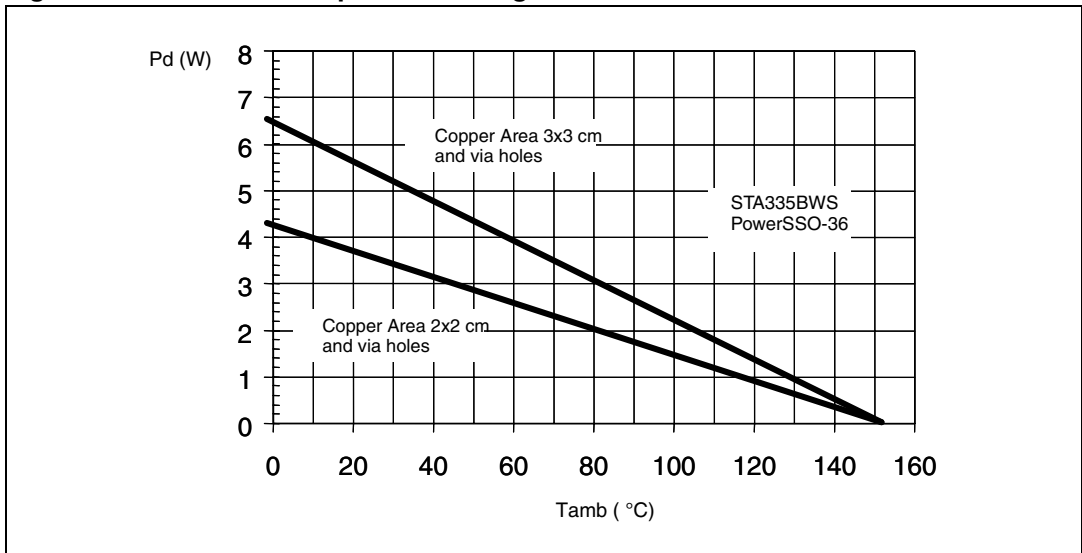

9 Package information

www.datasheet4u.com

In order to meet environmental requirements, ST offers these devices in ECOPACK[®] packages. These packages have a Lead-free second level interconnect. The category of second Level Interconnect is marked on the package and on the inner box label, in compliance with JEDEC Standard JESD97. The maximum ratings related to soldering conditions are also marked on the inner box label. ECOPACK is an ST trademark. ECOPACK specifications are available at: www.st.com.

Figure 22. PowerSSO-36 (slug-up) mechanical data and package dimensions

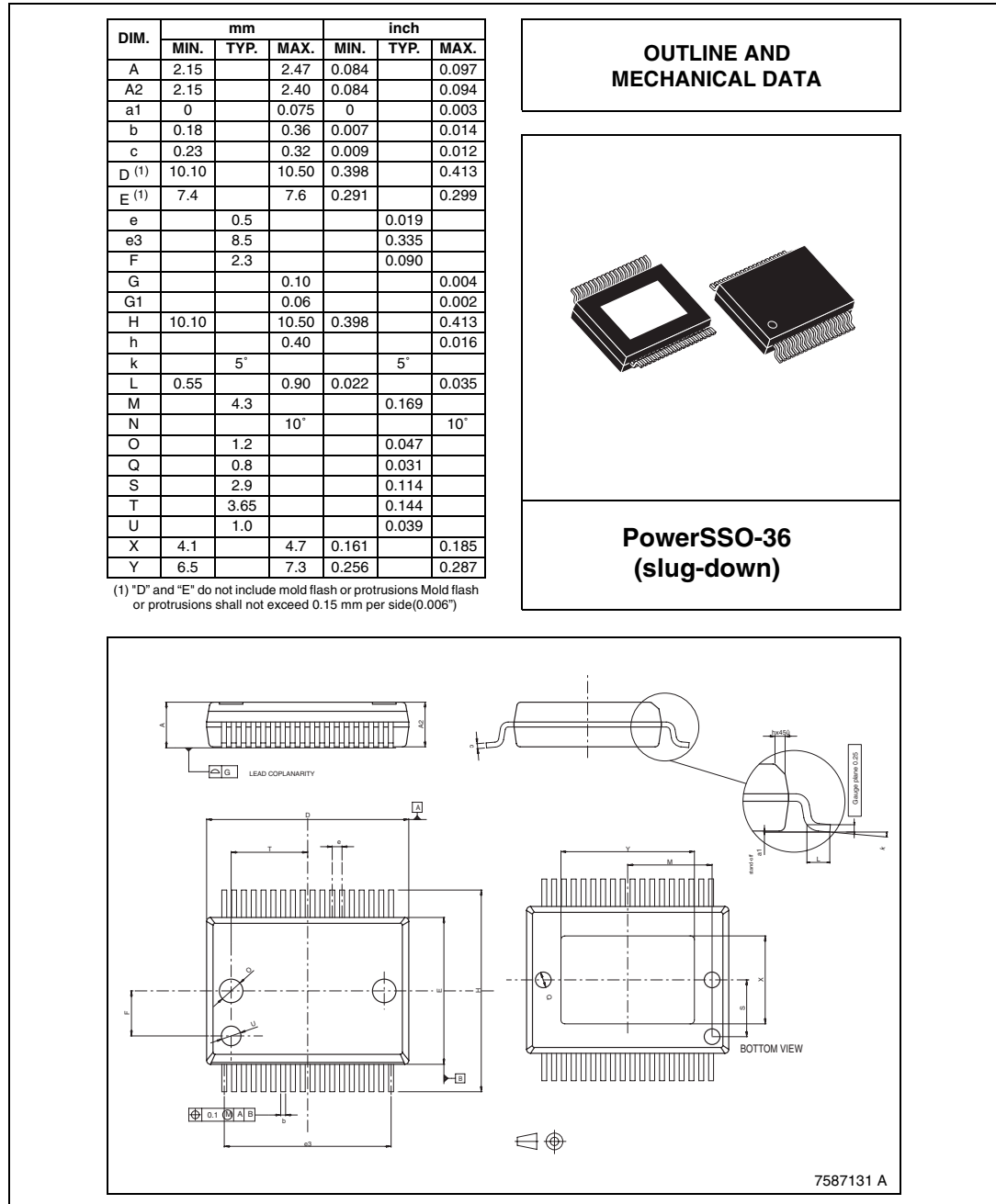

10 Trademarks and other acknowledgements

www.datasheet4u.com

DDX is a registered trademark of Apogee Technology Inc.

Sound Terminal is a trademark of STMicroelectronics.

ECOPACK is a registered trademark of STMicroelectronics.

11 Revision history

www.datasheet4u.com

Table 35. Document revision history

Date	Revision	Changes
18-Jan-2008	1	Initial release.

Please Read Carefully:

Information in this document is provided solely in connection with ST products. STMicroelectronics NV and its subsidiaries ("ST") reserve the right to make changes, corrections, modifications or improvements, to this document, and the products and services described herein at any time, without notice.

All ST products are sold pursuant to ST's terms and conditions of sale.

Purchasers are solely responsible for the choice, selection and use of the ST products and services described herein, and ST assumes no liability whatsoever relating to the choice, selection or use of the ST products and services described herein.

No license, express or implied, by estoppel or otherwise, to any intellectual property rights is granted under this document. If any part of this document refers to any third party products or services it shall not be deemed a license grant by ST for the use of such third party products or services, or any intellectual property contained therein or considered as a warranty covering the use in any manner whatsoever of such third party products or services or any intellectual property contained therein.

UNLESS OTHERWISE SET FORTH IN ST'S TERMS AND CONDITIONS OF SALE ST DISCLAIMS ANY EXPRESS OR IMPLIED WARRANTY WITH RESPECT TO THE USE AND/OR SALE OF ST PRODUCTS INCLUDING WITHOUT LIMITATION IMPLIED WARRANTIES OF MERCHANTABILITY, FITNESS FOR A PARTICULAR PURPOSE (AND THEIR EQUIVALENTS UNDER THE LAWS OF ANY JURISDICTION), OR INFRINGEMENT OF ANY PATENT, COPYRIGHT OR OTHER INTELLECTUAL PROPERTY RIGHT.

UNLESS EXPRESSLY APPROVED IN WRITING BY AN AUTHORIZED ST REPRESENTATIVE, ST PRODUCTS ARE NOT RECOMMENDED, AUTHORIZED OR WARRANTED FOR USE IN MILITARY, AIR CRAFT, SPACE, LIFE SAVING, OR LIFE SUSTAINING APPLICATIONS, NOR IN PRODUCTS OR SYSTEMS WHERE FAILURE OR MALFUNCTION MAY RESULT IN PERSONAL INJURY, DEATH, OR SEVERE PROPERTY OR ENVIRONMENTAL DAMAGE. ST PRODUCTS WHICH ARE NOT SPECIFIED AS "AUTOMOTIVE GRADE" MAY ONLY BE USED IN AUTOMOTIVE APPLICATIONS AT USER'S OWN RISK.

Resale of ST products with provisions different from the statements and/or technical features set forth in this document shall immediately void any warranty granted by ST for the ST product or service described herein and shall not create or extend in any manner whatsoever, any liability of ST.

ST and the ST logo are trademarks or registered trademarks of ST in various countries.

Information in this document supersedes and replaces all information previously supplied.

The ST logo is a registered trademark of STMicroelectronics. All other names are the property of their respective owners.

© 2008 STMicroelectronics - All rights reserved

STMicroelectronics group of companies

Australia - Belgium - Brazil - Canada - China - Czech Republic - Finland - France - Germany - Hong Kong - India - Israel - Italy - Japan - Malaysia - Malta - Morocco - Singapore - Spain - Sweden - Switzerland - United Kingdom - United States of America

www.st.com