

40 V, 3.5 A quad power half-bridge

Datasheet - production data

Description

The STA518 is a monolithic quad half-bridge stage in multipower BCD technology. The device can be used also as dual bridge or reconfigured, by connecting the CONFIG pin to the V_{dd} pin, as a single bridge with double current capacity.

The device is particularly designed to make the output stage of a stereo all-digital high-efficiency (DDX™) amplifier capable of delivering an output power of 24 W x 4 channels @ THD = 10% at V_{CC} 30 V into a 4 Ω load in single-ended configuration.

It can also deliver 50 + 50 W @ THD = 10% at V_{CC} 29 V as output power into an 8 Ω load in BTL configuration and 70 W @ THD = 10% at V_{CC} 34 V into 8 Ω in a single paralleled BTL configuration.

The input pins have a threshold proportional to the V_L pin voltage.

Features

- Multipower BCD technology
- Minimum input output pulse width distortion
- 200 m Ω R_{dsON} complementary DMOS output stage
- CMOS-compatible logic inputs
- Thermal protection
- Thermal warning output
- Undervoltage protection
- Short-circuit protection

Table 1. Device summary

Order code	Temperature range °C	Package	Packaging
STA51813TR	-40 to 90	PowerSSO36 (slug up)	Tape & reel

Contents

1	Audio application circuit	5
2	Pin description	6
3	Electrical specifications	8
3.1	Absolute maximum ratings	8
3.2	Recommended operating conditions	8
3.3	Thermal data	8
3.4	Thermal information	8
3.5	Electrical characteristics	9
4	Technical information	12
4.1	Logic interface and decode	12
4.2	Power outputs	13
4.3	Parallel output / high current operation	13
4.4	Additional information	13
5	Characterization curves	15
6	Package information	17
7	Revision history	20

List of tables

Table 1.	Device summary	1
Table 2.	Pin function	6
Table 3.	Functional pin status	7
Table 4.	Absolute maximum ratings	8
Table 5.	Recommended operating conditions	8
Table 6.	Thermal data	8
Table 7.	Electrical characteristics	9
Table 8.	V_{LOW} , V_{HIGH} variation with I_{bias}	10
Table 9.	Logic truth table (see Figure 4)	10
Table 10.	PowerSO36 exposed pad up dimensions	19
Table 11.	Document revision history	20

List of figures

Figure 1.	Audio application circuit (quad single-ended)	5
Figure 2.	Pin connections (top view)	6
Figure 3.	Low-current dead time for single-ended application: test circuit.	11
Figure 4.	High-current dead time for bridge application: block diagram.	11
Figure 5.	High-current dead time for bridge application: test circuit.	11
Figure 6.	STA518 block diagram full-bridge DDX [®] or binary modes	12
Figure 7.	STA518 block diagram binary half-bridge mode	12
Figure 8.	Typical stereo full-bridge configuration to obtain 50 + 50 W @ THD = 10%, $R_L = 8 \Omega$, $V_{CC} = 29 V$	14
Figure 9.	Typical single BTL configuration to obtain 70 W @ THD 10%, $R_L = 8 \Omega$, $V_{CC} = 34 V$	14
Figure 10.	Power dissipation vs. output power	15
Figure 11.	Power derating curve	15
Figure 12.	THD+N vs. output power	15
Figure 13.	Output power vs. supply voltage.	15
Figure 14.	THD vs. frequency	15
Figure 15.	Output power vs. supply voltage.	16
Figure 16.	THD+N vs. output power	16
Figure 17.	Power dissipation vs. output power	16
Figure 18.	THD+N vs. output power	16
Figure 19.	PSSO36 (slug up) mechanical outline	18

1 Audio application circuit

Figure 1. Audio application circuit (quad single-ended)

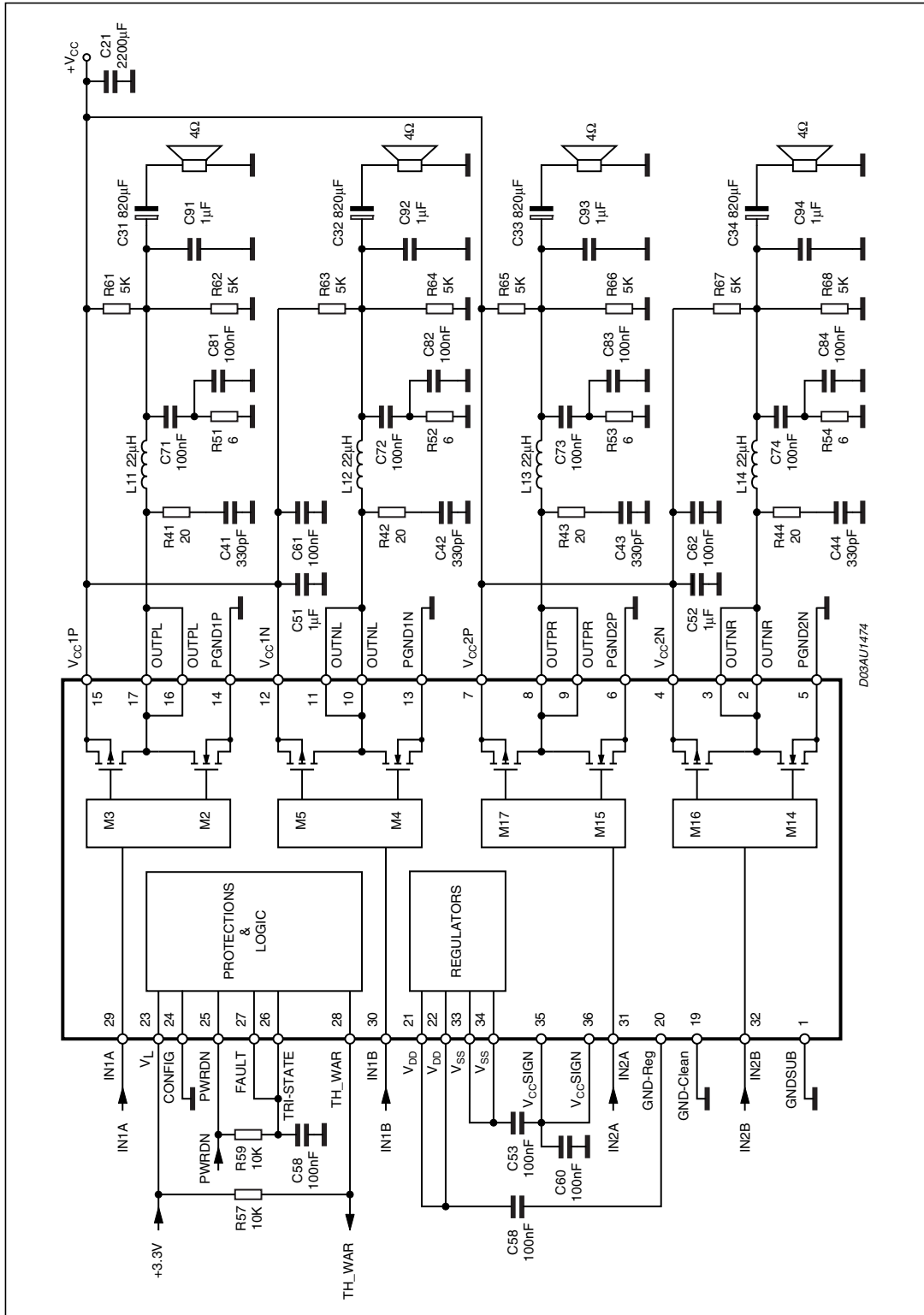

2 Pin description

Figure 2. Pin connections (top view)

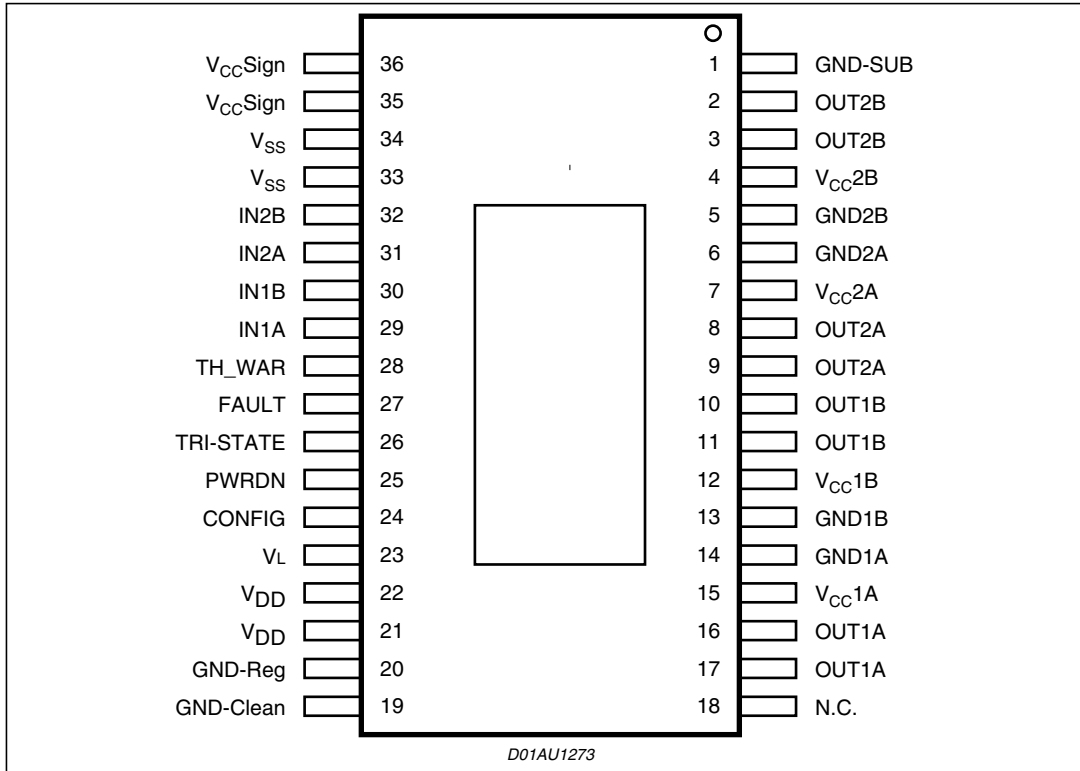

Table 2. Pin function

Pin n°	Name	Description
1	GND-SUB	Substrate ground
2, 3	OUT2B	Output half-bridge 2B
4	V _{CC} 2B	Positive supply
5	GND2B	Negative supply
6	GND2A	Negative supply
7	V _{CC} 2A	Positive supply
8, 9	OUT2A	Output half-bridge 2A
10, 11	OUT1B	Output half-bridge 1B
12	V _{CC} 1B	Positive supply
13	GND1B	Negative supply
14	GND1A	Negative supply
15	V _{CC} 1A	Positive supply
16, 17	OUT1A	Output half-bridge 1A
18	NC	Not connected

Table 2. Pin function (continued)

Pin n°	Name	Description
19	GND-clean	Logical ground
20	GND-Reg	Ground for regulator V_{dd}
21, 22	V_{dd}	5 V regulator referred to ground
23	V_L	Logic reference voltage
24	CONFIG	Configuration pin
25	PWRDN	Short-circuit pin
26	TRI-STATE	Hi-Z pin
27	FAULT	Fault pin advisor
28	TH_WAR	Thermal warning advisor
29	IN1A	Input of half-bridge 1A
30	IN1B	Input of half-bridge 1B
31	IN2A	Input of half-bridge 2A
32	IN2B	Input of half-bridge 2B
33, 34	V_{ss}	5 V regulator referred to $+V_{CC}$
35, 36	V_{CC} Sign	Signal positive supply

Table 3. Functional pin status

Pin name	Pin n°	Logical value	IC - status
FAULT	27	0	Fault detected (short-circuit, or thermal)
FAULT *	27	1	Normal operation
TRI-STATE	26	0	All powers in Hi-Z state
TRI-STATE	26	1	Normal operation
PWRDN	25	0	Low consumption
PWRDN	25	1	Normal operation
TH_WAR	28	0	Temperature of the IC = 130 °C
TH_WAR ⁽¹⁾	28	1	Normal operation

1. The pin is an open collector. To have a high logic value, it needs to be pulled up by a resistor.

3 Electrical specifications

3.1 Absolute maximum ratings

Table 4. Absolute maximum ratings

Symbol	Parameter	Value	Unit
V_{CC}	DC supply voltage (pin 4, 7, 12, 15)	40	V
V_{max}	Maximum voltage on pins 23 to 32	5.5	V
T_{op}	Operating temperature range	-40 to 90	°C
P_{tot}	Power dissipation ($T_{case} = 70\text{ °C}$)	21	W
T_{stg}, T_j	Storage and junction temperature	-40 to 150	°C

3.2 Recommended operating conditions

Table 5. Recommended operating conditions ⁽¹⁾

Symbol	Parameter	Min.	Typ.	Max.	Unit
V_{CC}	DC supply voltage	10		36.0	V
V_L	Input logic reference	2.7	3.3	5.0	V
T_{amb}	Ambient temperature	0		70	°C

1. Performance not guaranteed beyond recommended operating conditions

3.3 Thermal data

Table 6. Thermal data ⁽¹⁾

Symbol	Parameter	Min.	Typ.	Max.	Unit
T_{j-case}	Thermal resistance junction to case (thermal pad)			1.5	°C/W
T_{jSD}	Thermal shut-down junction temperature		150		°C
T_{warn}	Thermal warning temperature		130		°C
t_{hSD}	Thermal shut-down hysteresis		25		°C

1. See thermal information

3.4 Thermal information

The power dissipated within the device depends primarily on the supply voltage, load impedance and output modulation level. The PSSO36 package of the STA518 includes an exposed thermal slug on the top of the device to provide a direct thermal path from the IC to the heatsink. For the quad single-ended application the dissipated power vs. output power is shown in [Figure 10](#).

Considering that for the STA518 the thermal resistance junction to slug is 1.5 °C/W and the estimated thermal resistance due to the grease placed between slug and heat sink is 2.3 °C/W (the use of thermal pads for this package is not recommended), the suitable heat sink R_{th} to be used can be drawn from the following graph *Figure 11*, where is shown the derating power vs. t_{amb} for different heat sinks.

3.5 Electrical characteristics

Refer to the circuit in *Figure 3* ($V_L = 3.3$ V; $V_{CC} = 30$ V; $R_L = 8$ Ω ; $f_{sw} = 384$ kHz; $T_{amb} = 25$ °C unless otherwise specified)

Table 7. Electrical characteristics

Symbol	Parameter	Test conditions	Min.	Typ.	Max.	Unit
R_{dsON}	Power P-channel / N-channel MOSFET R_{dsON}	$I_d = 1$ A		200	270	m Ω
I_{dss}	Power P-channel / N-channel leakage I_{dss}	$V_{CC} = 35$ V			50	μ A
g_N	Power P-channel R_{dsON} matching	$I_d = 1$ A	95			%
g_P	Power N-channel R_{dsON} matching	$I_d = 1$ A	95			%
Dt_s	Low current dead time (static)	see test circuit <i>Figure 3</i>		10	20	ns
Dt_d	High current dead time (dynamic)	$L = 22$ μ H; $C = 470$ nF; $R_L = 8$ Ω $I_d = 3$ A; see <i>Figure 5</i>			50	ns
t_{dON}	Turn-on delay time	Resistive load; $V_{CC} = 30$ V			100	ns
t_{dOFF}	Turn-off delay time	Resistive load; $V_{CC} = 30$ V			100	ns
t_r	Rise time	Resistive load; as <i>Figure 3</i>			25	ns
t_f	Fall time				25	ns
V_{CC}	Supply voltage operating voltage		10		36	V
V_{IN-H}	High-level input voltage				$V_L/2 + 300$ mV	V
V_{IN-L}	Low-level input voltage		$V_L/2 - 300$ mV			V
I_{IN-H}	High-level input current	Pin voltage = V_L		1		μ A
I_{IN-L}	Low-level input current	Pin voltage = 0.3 V		1		μ A
$I_{PWRDN-H}$	High-level PWRDN pin input current	$V_L = 3.3$ V		35		μ A
V_{LOW}	Low logical state voltage V_{LLOW} (pin PWRDN, TRISTATE) ⁽¹⁾	$V_L = 3.3$ V	0.8			V
V_{HIGH}	High logical state voltage V_{LHIGH} (pin PWRDN, TRISTATE) ⁽¹⁾	$V_L = 3.3$ V			1.7	V
$I_{VCC-PWRDN}$	Supply current from V_{CC} in power down	PWRDN = 0			3	mA

Table 7. Electrical characteristics (continued)

Symbol	Parameter	Test conditions	Min.	Typ.	Max.	Unit
I_{FAULT}	Output current pins FAULT, TH_WAR when fault conditions	$V_{\text{pin}} = 3.3 \text{ V}$		1		mA
$I_{\text{VCC-hiz}}$	Supply current from V_{CC} in Tri-state	$V_{\text{CC}} = 30 \text{ V}$; Tri-state = 0		22		mA
I_{VCC}	Supply current from V_{CC} in operation (both channels switching)	$V_{\text{CC}} = 30\text{V}$; Input pulse width = 50% Duty; Switching frequency = 384 kHz; No LC filters;		50		mA
$I_{\text{VCC-q}}$	I_{sc} (short-circuit current limit) ⁽²⁾	$V_{\text{CC}} = 30 \text{ V}$	3.5	6		A
V_{UV}	Undervoltage protection threshold			7		V
$t_{\text{pw_min}}$	Output minimum pulse width	No load	70		150	ns

1. [Table 8](#) explains the V_{LOW} , V_{HIGH} variation with I_{bias} .
2. See relevant Application Note AN1994

Table 8. V_{LOW} , V_{HIGH} variation with I_{bias}

V_{L}	$V_{\text{Low min}}$	$V_{\text{High max}}$	Unit
2.7	0.7	1.5	V
3.3	0.8	1.7	V
5	0.85	1.85	V

Table 9. Logic truth table (see [Figure 4](#))

TRI-STATE	INxA	INxB	Q1	Q2	Q3	Q4	Output mode
0	x	x	OFF	OFF	OFF	OFF	Hi-Z
1	0	0	OFF	OFF	ON	ON	DUMP
1	0	1	OFF	ON	ON	OFF	NEGATIVE
1	1	0	ON	OFF	OFF	ON	POSITIVE
1	1	1	ON	ON	OFF	OFF	Not used

Figure 3. Low-current dead time for single-ended application: test circuit

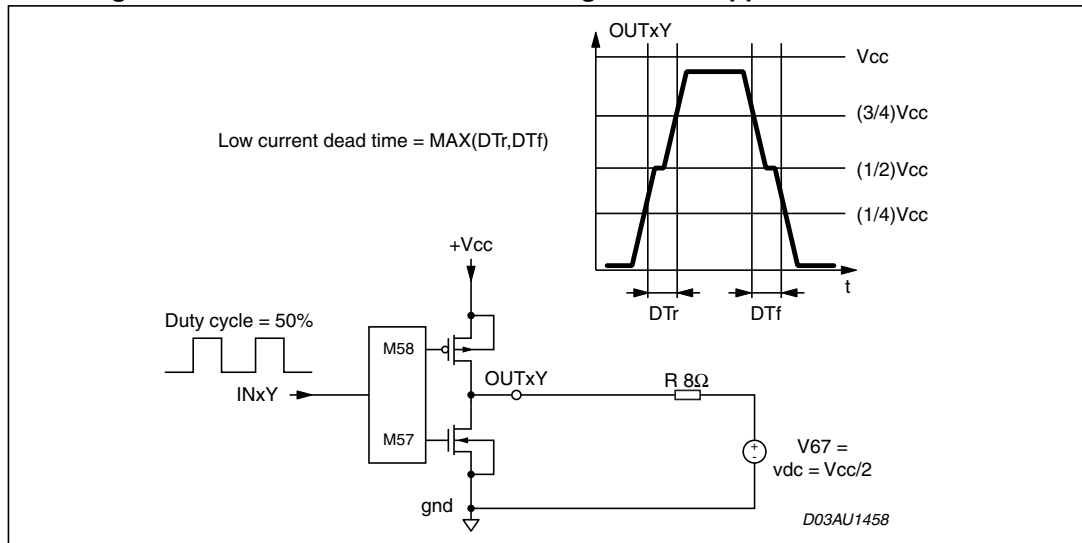

Figure 4. High-current dead time for bridge application: block diagram

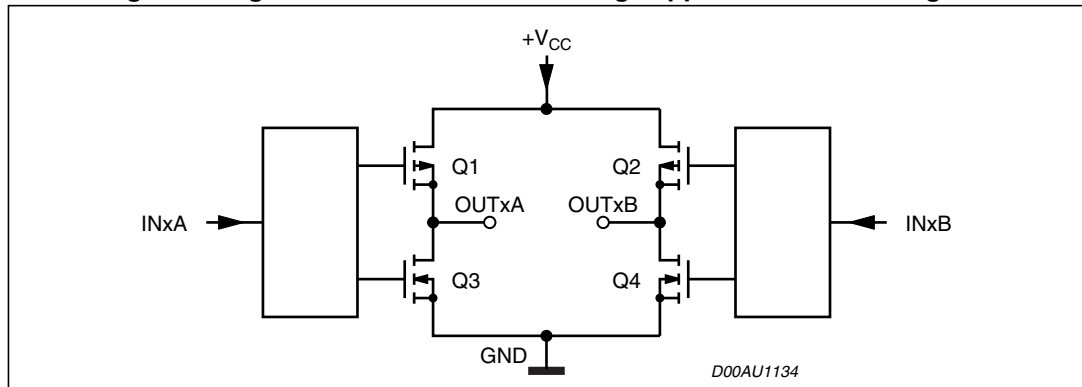
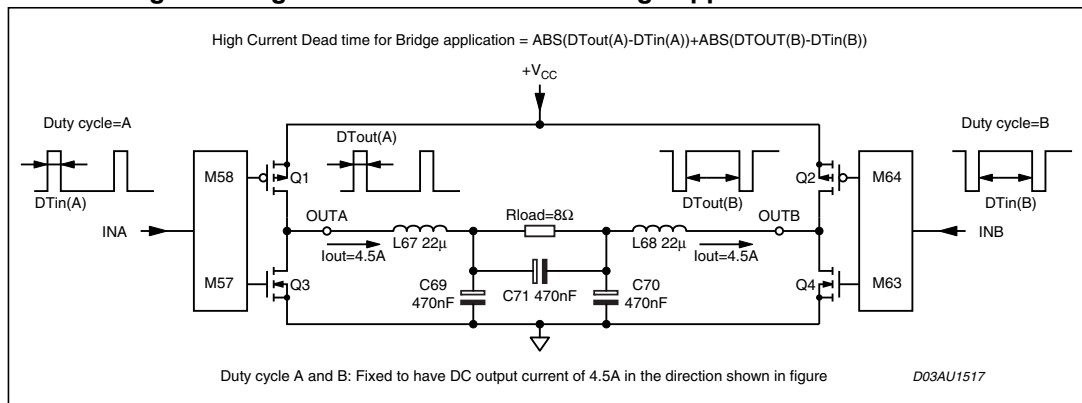

Figure 5. High-current dead time for bridge application: test circuit



4 Technical information

The STA518 is a high-efficiency dual-channel H-Bridge that is able to deliver 50 W per channel (@ THD = 10% $R_L = 8 \Omega$, $V_{CC} = 29 V$) of audio output power.

The STA518 converts both DDX and binary-controlled PWM signals into audio power at the load. It includes a logic interface, integrated bridge drivers, high-efficiency MOSFET outputs and thermal and short-circuit protection circuitry.

In DDX mode, two logic level signals per channel are used to control high-speed MOSFET switches to connect the speaker load to the input supply or to ground in a bridge configuration, according to the damped ternary modulation operation.

In binary mode operation, both full-bridge and half-bridge modes are supported. The STA518 includes overcurrent and thermal protection as well as an undervoltage lockout with automatic recovery. A thermal warning status is also provided.

Figure 6. STA518 block diagram full-bridge DDX® or binary modes

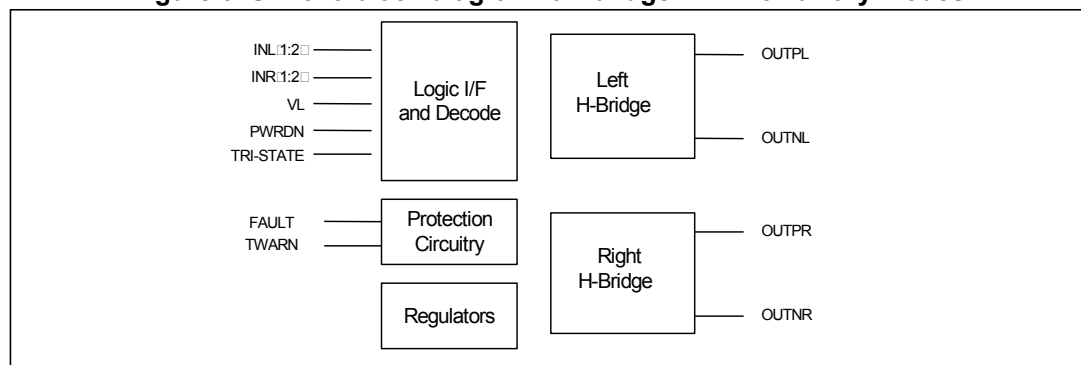
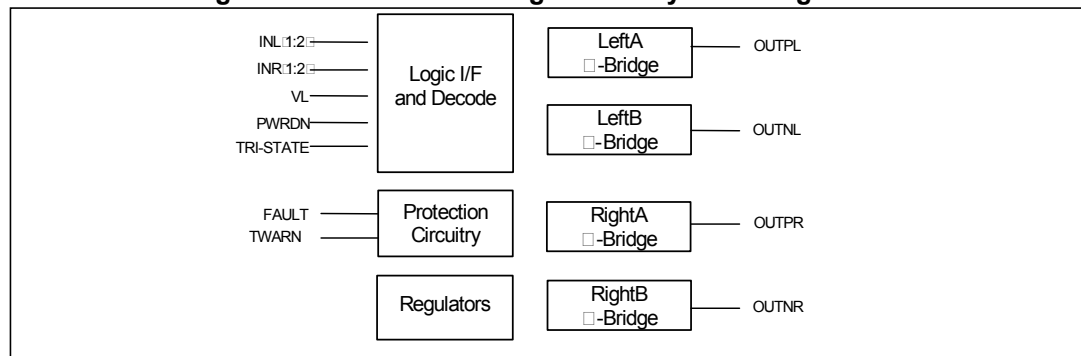

Figure 7. STA518 block diagram binary half-bridge mode



4.1 Logic interface and decode

The STA518 power outputs are controlled using one or two logic level timing signals. In order to provide a proper logic interface, the V_{bias} input must operate at the same voltage as the DDX control logic supply.

Protection circuitry:

The STA518 includes protection circuitry for overcurrent and thermal overload conditions. A thermal warning pin (pin 28) is activated low (open-drain MOSFET) when the IC

temperature exceeds 130 °C, in advance of the thermal shutdown protection. When a fault condition is detected, an internal fault signal acts to immediately disable the output power MOSFETs, placing both H-Bridges in high impedance state. At the same time an open-drain MOSFET connected to the FAULT pin (pin 27) is switched on.

There are two possible modes subsequent to activating a fault:

1. **SHUTDOWN mode:** with FAULT (pull-up resistor) and TRI-STATE pins independent, an activated fault will disable the device, signaling low at the FAULT output. The device may subsequently be reset to normal operation by toggling the TRI-STATE pin from high to low to high using an external logic signal.
2. **AUTOMATIC recovery mode:** This is shown in the audio application circuit of quad single-ended. The FAULT and TRI-STATE pins are shorted together and connected to a time constant circuit comprising R59 and C58. An activated FAULT will force a reset on the TRI-STATE pin causing normal operation to resume following a delay determined by the time constant of the circuit. If the fault condition is still present, the circuit operation will continue repeating until the fault condition is removed. An increase in the time constant of the circuit will produce a longer recovery interval. Care must be taken in the overall system design as not to exceed the protection thresholds under normal operation.

4.2 Power outputs

The STA518 power and output pins are duplicated to provide a low impedance path for the device's bridged outputs. All duplicate power, ground and output pins must be connected for proper operation.

The PWRDN or TRI-STATE pins should be used to set all MOSFETS to the Hi-Z state during power-up until the logic power supply, V_L , is settled.

4.3 Parallel output / high current operation

When using DDX mode output, the STA518 outputs can be connected in parallel in order to increase the output current capability to a load. In this configuration the STA518 can provide 70 W into 8 ohm.

This mode of operation is enabled with the CONFIG pin (pin 24) connected to VREG1 and the inputs combined INLA=INLB, INRA=INRB and the outputs combined OUTLA=OTLB, OUTRA=OUTRB.

4.4 Additional information

Output Filter: A passive 2nd order passive filter is used on the STA518 power outputs to reconstruct an analog audio signal. System performance can be significantly affected by the output filter design and choice of passive components. A filter design for 6 ohm / 8 ohm loads is shown in the typical application circuit of [Figure 9](#).

Quad single-ended circuit ([Figure 1](#)) shows a filter for half-bridge mode, 4 ohm loads.

Figure 8. Typical stereo full-bridge configuration to obtain 50 + 50 W @ THD = 10%, $R_L = 8 \Omega$, $V_{CC} = 29 V$

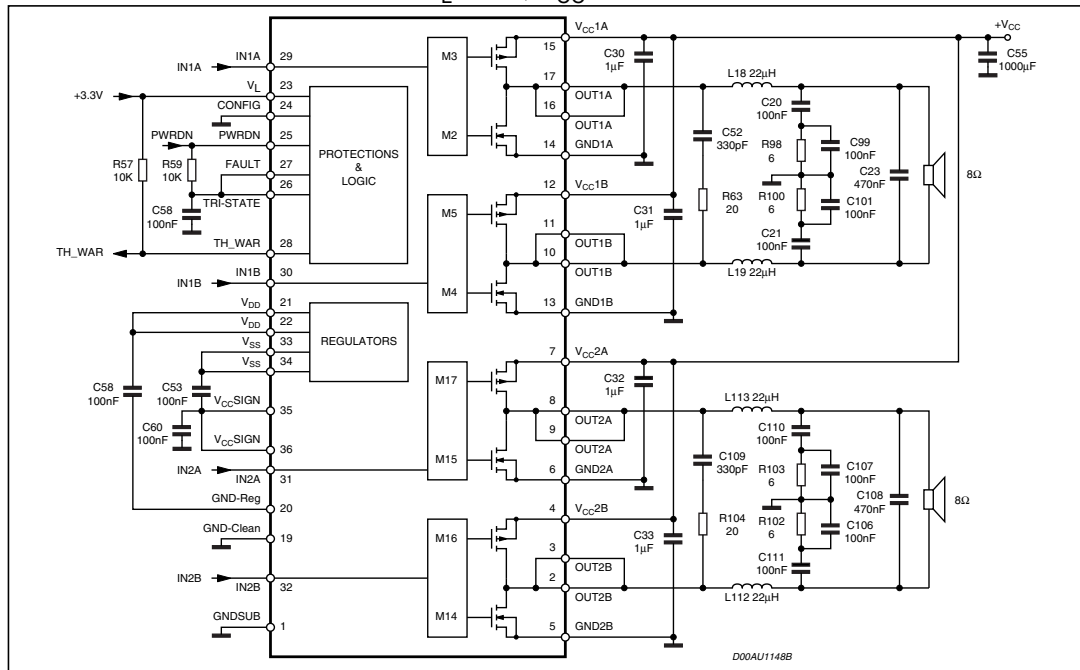
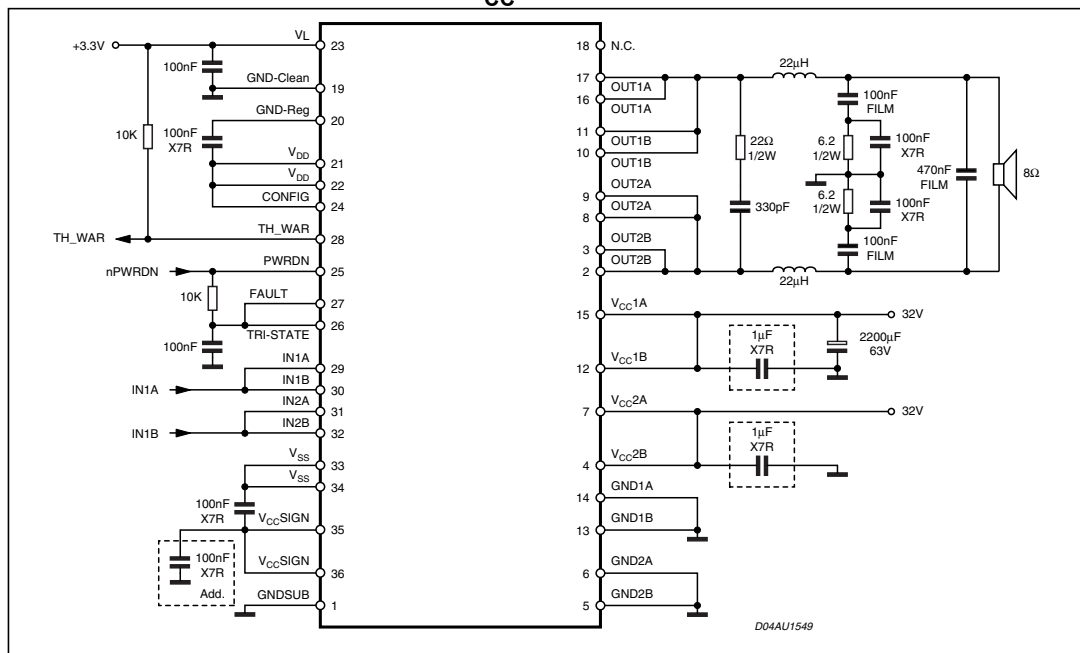

Figure 9. Typical single BTL configuration to obtain 70 W @ THD 10%, $R_L = 8 \Omega$, $V_{CC} = 34 V(a)$



a. A PWM modulator as driver is needed. In particular, this result is achieved using the STA308 + STA518 + STA50X demo board. Peak Power for $t \leq 1\text{sec}$.

5 Characterization curves

The following characterization curves are obtained using the quad single-ended configuration (Figure 1) with an STA308A controller.

Figure 10. Power dissipation vs. output power

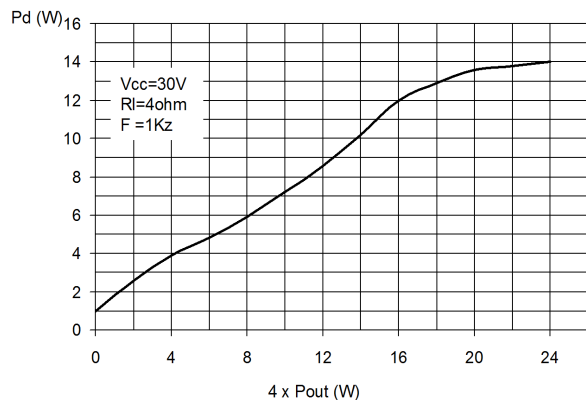

Figure 11. Power derating curve

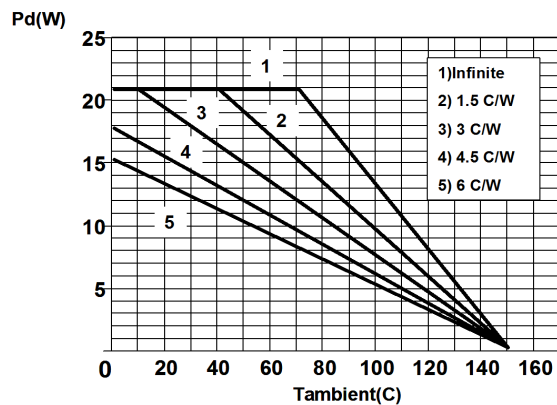

Figure 12. THD+N vs. output power

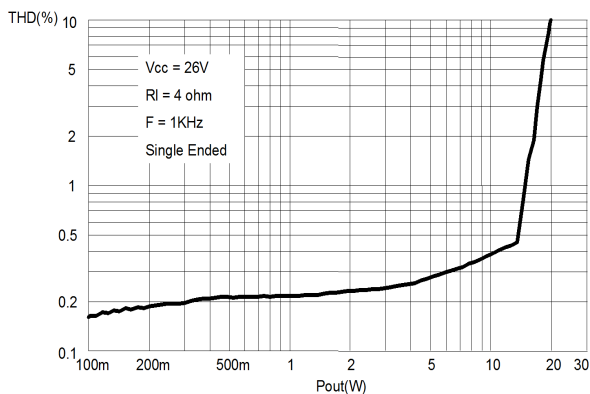

Figure 13. Output power vs. supply voltage

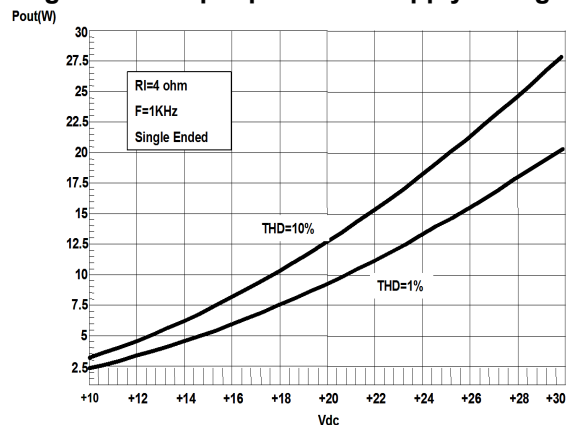
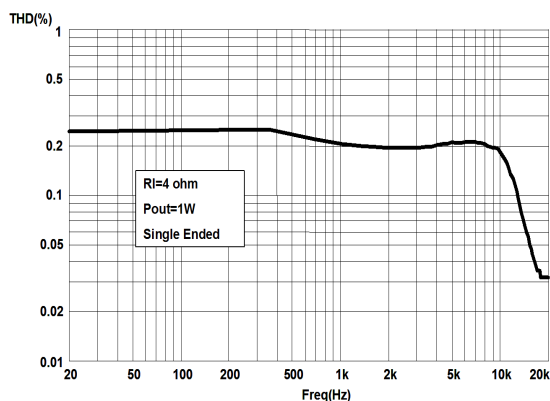
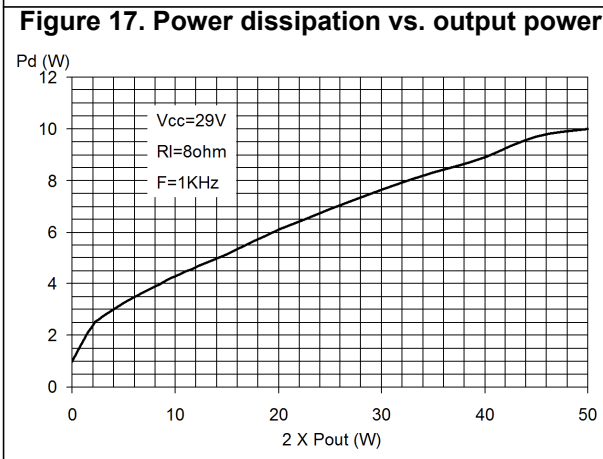
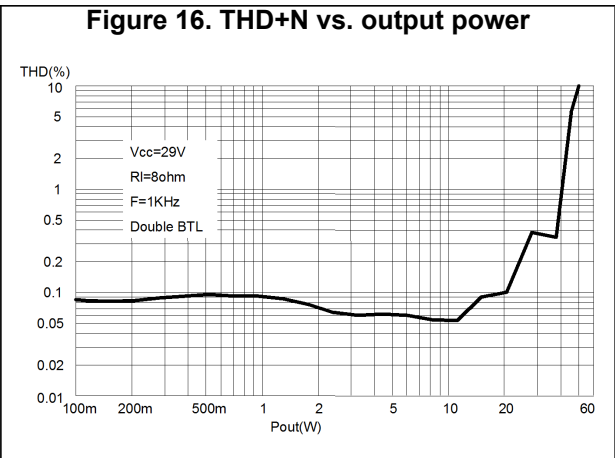
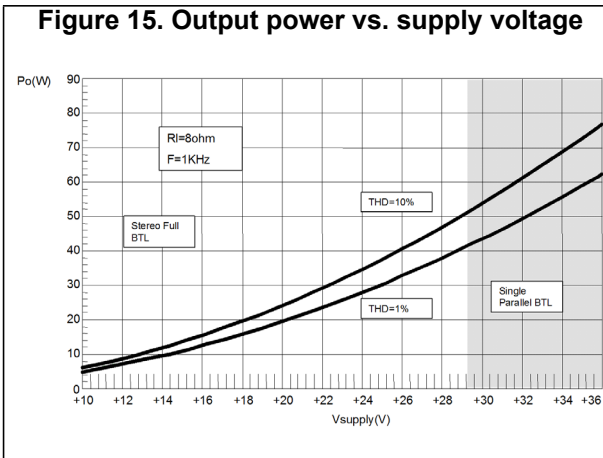

Figure 14. THD vs. frequency



The following characterizations are obtained using the stereo full-bridge configuration (Figure 8) with STA308A controller.



The following characterization is obtained using a single BTL configuration (Figure 9) with the STA308A controller.

Figure 18. THD+N vs. output power

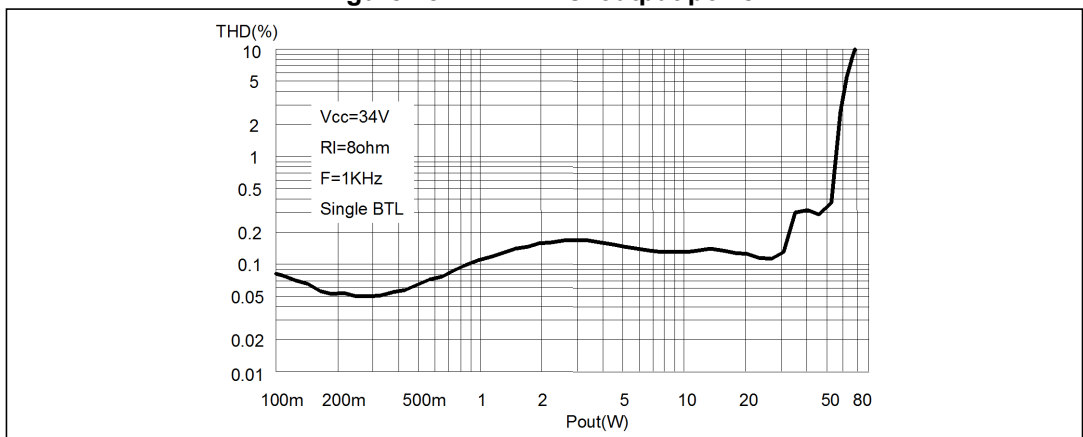

6 Package information

In order to meet environmental requirements, ST offers these devices in different grades of ECOPACK[®] packages, depending on their level of environmental compliance. ECOPACK[®] specifications, grade definitions and product status are available at: www.st.com. ECOPACK[®] is an ST trademark.

Figure 19. PSSO36 (slug up) mechanical outline

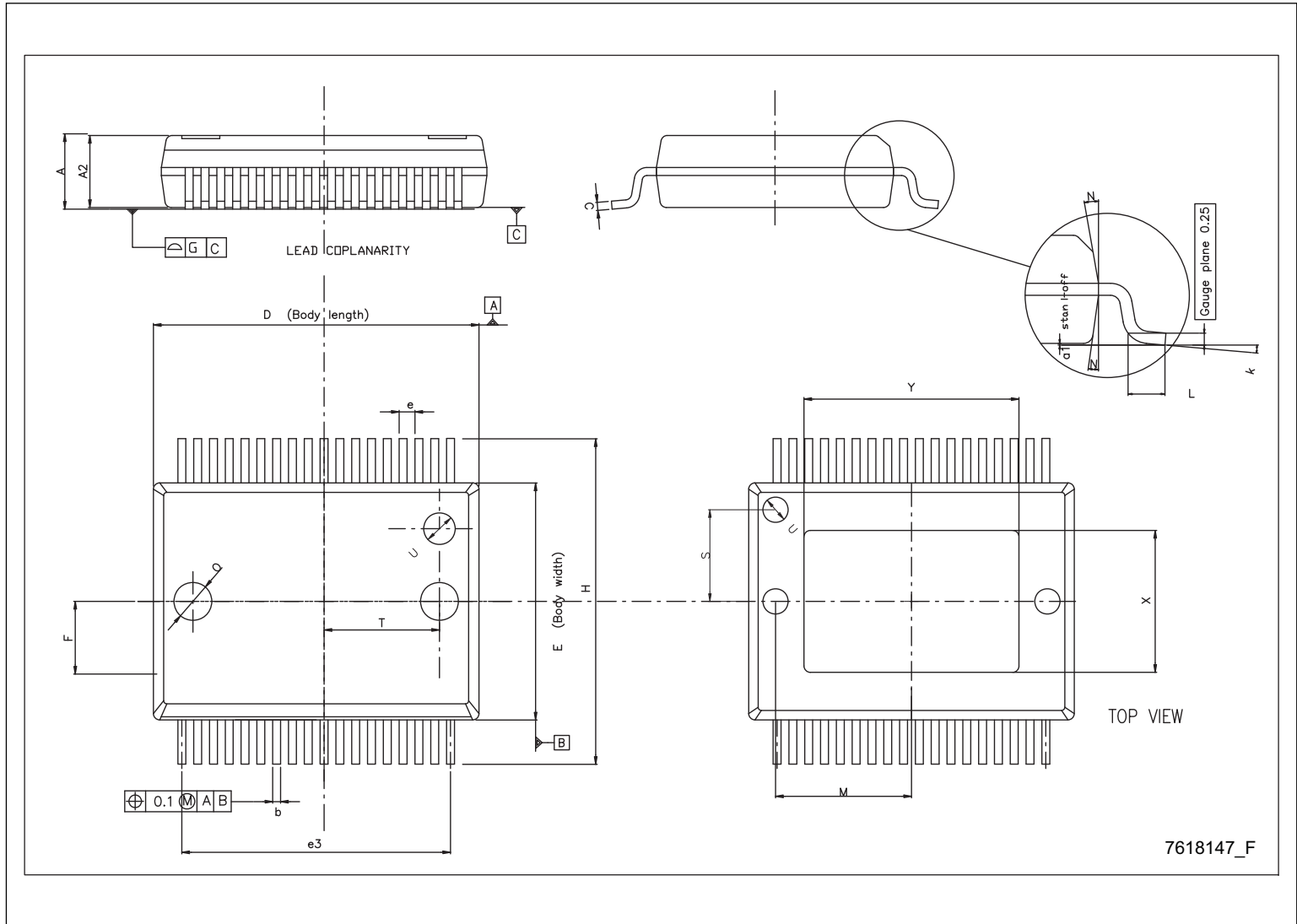

Table 10. PowerSO36 exposed pad up dimensions

Symbol	Dimensions in mm.			Dimensions in inch.		
	Min.	Typ.	Max.	Min.	Typ.	Max.
A	2.15	-	2.45	0.085	-	0.096
A2	2.15	-	2.35	0.085	-	0.092
a1	0	-	0.1	0.00	-	0.004
b	0.18	-	0.36	0.007	-	0.014
c	0.23	-	0.32	0.009	-	0.013
D	10.10	-	10.50	0.398	-	0.413
E	7.4	-	7.6	0.291	-	0.299
e	-	0.5	-	-	0.020	-
e3	-	8.5	-	-	0.335	-
F	-	2.3	-	-	0.091	-
G	-	-	0.1	-	-	0.004
H	10.1	-	10.5	-	-	0.413
h	-	-	0.4	-	-	0.016
k	0 deg	-	8 deg	0 deg	-	8 deg
L	0.55	-	0.85	0.022		0.033
M	-	4.3	-	-	0.169	-
N	-	-	10 deg	-	-	10 deg
O	-	1.2	-	-	0.047	-
Q	-	0.8	-	-	0.031	-
S	-	2.9	-	-	0.114	-
T	-	3.65	-	-	0.114	-
U	-	1.0	-	-	0.039	-

7 Revision history

Table 11. Document revision history

Date	Revision	Changes
19-Aug-2004	1	Initial release.
11-Nov-2004	2	Changed symbol in "Electrical Characteristics".
18-May-2006	3	Changed operating temperature range value to -40 to 90°C (see Table 4).
26-Feb-2014	4	Updated order code Table 1 on page 1 .
11-Jul-2014	5	Updated figure in cover page.
16-Sep-2014	6	Updated package information (Figure 19 , Table 10 , and cover page) Minor textual updates

IMPORTANT NOTICE – PLEASE READ CAREFULLY

STMicroelectronics NV and its subsidiaries (“ST”) reserve the right to make changes, corrections, enhancements, modifications, and improvements to ST products and/or to this document at any time without notice. Purchasers should obtain the latest relevant information on ST products before placing orders. ST products are sold pursuant to ST’s terms and conditions of sale in place at the time of order acknowledgement.

Purchasers are solely responsible for the choice, selection, and use of ST products and ST assumes no liability for application assistance or the design of Purchasers’ products.

No license, express or implied, to any intellectual property right is granted by ST herein.

Resale of ST products with provisions different from the information set forth herein shall void any warranty granted by ST for such product.

ST and the ST logo are trademarks of ST. All other product or service names are the property of their respective owners.

Information in this document supersedes and replaces information previously supplied in any prior versions of this document.

© 2014 STMicroelectronics – All rights reserved