



STAC2932B

RF power transistors HF/VHF/UHF N-channel MOSFETs

Features

- Gold metallization
- Excellent thermal stability
- Common source push-pull configuration
- $P_{OUT} = 300 \text{ W min.}$
with 20 dB gain @ 175 MHz
- In compliance with the 2002/95/EC
European directive

Description

The STAC2932B is a gold metallized N-channel MOS field-effect RF power transistor. It is intended for use in 50 V DC large signal applications up to 250 MHz.



Figure 1. Pin connection

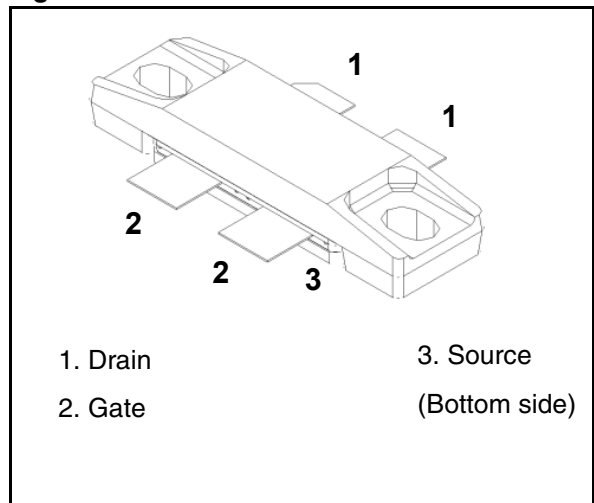

Table 1. Device summary

Order code	Marking	Package	Packaging
STAC2932B	STAC2932	STAC244B	Plastic tray

Contents

www.datasheet4u.com

1	Electrical data	3
1.1	Maximum ratings	3
1.2	Thermal data	3
2	Electrical characteristics	4
2.1	Static	4
2.2	Dynamic	4
3	Impedance	5
4	Typical performance	6
5	Test circuit	8
6	Package mechanical data	10
7	Revision history	12



1 Electrical data

1.1 Maximum ratings

www.datasheet4u.com

Table 2. Absolute maximum ratings ($T_{CASE} = 25\text{ °C}$)

Symbol	Parameter	Value	Unit
$V_{(BR)DSS}^{(1)}$	Drain source voltage	125	V
V_{DGR}	Drain-gate voltage ($R_{GS} = 1\text{ M}\Omega$)	125	V
V_{GS}	Gate-source voltage	± 20	V
I_D	Drain current	40	A
P_{DISS}	Power dissipation	625	W
T_J	Max. operating junction temperature	200	$^{\circ}\text{C}$
T_{STG}	Storage temperature	-65 to +150	$^{\circ}\text{C}$

1. $T_J = 150\text{ °C}$

1.2 Thermal data

Table 3. Thermal data

Symbol	Parameter	Value	Unit
R_{thJC}	Junction - case thermal resistance	0.28	$^{\circ}\text{C/W}$

2 Electrical characteristics

$$T_{\text{CASE}} = +25\text{ }^{\circ}\text{C}$$

www.datasheet4u.com

2.1 Static

Table 4. Static (per side)

Symbol	Test conditions		Min.	Typ.	Max.	Unit
$V_{(\text{BR})\text{DSS}}$	$V_{\text{GS}} = 0\text{ V}$	$I_{\text{DS}} = 100\text{ mA}$	125			V
I_{DSS}	$V_{\text{GS}} = 0\text{ V}$	$V_{\text{DS}} = 50\text{ V}$			50	μA
I_{GSS}	$V_{\text{GS}} = 20\text{ V}$	$V_{\text{DS}} = 0\text{ V}$			250	nA
$V_{\text{GS(Q)}}$	$V_{\text{DS}} = 10\text{ V}$	$I_{\text{D}} = 250\text{ mA}$	1.5	2.5	4.0	V
$V_{\text{DS(ON)}}$	$V_{\text{GS}} = 10\text{ V}$	$I_{\text{D}} = 10\text{ A}$			3.0	V
G_{FS}	$V_{\text{DS}} = 10\text{ V}$	$I_{\text{D}} = 5\text{ A}$	5			S
C_{ISS}	$V_{\text{GS}} = 0\text{ V}$ $V_{\text{DS}} = 50\text{ V}$ $f = 1\text{ MHz}$			468		pF
C_{OSS}				206		pF
C_{RSS}				16		pF

2.2 Dynamic

Table 5. Dynamic

Symbol	Test conditions	Min.	Typ.	Max.	Unit
P_{OUT}	$V_{\text{DD}} = 50\text{ V}$, $I_{\text{DQ}} = 2 \times 250\text{ mA}$, $P_{\text{IN}} = 4\text{ W}$, $f = 175\text{ MHz}$	300	390		W
h_{D}	$V_{\text{DD}} = 50\text{ V}$, $I_{\text{DQ}} = 2 \times 250\text{ mA}$, $P_{\text{IN}} = 4\text{ W}$, $f = 175\text{ MHz}$	55	68		%

3 Impedance

www.datasheet4u.com

Figure 2. Current conventions

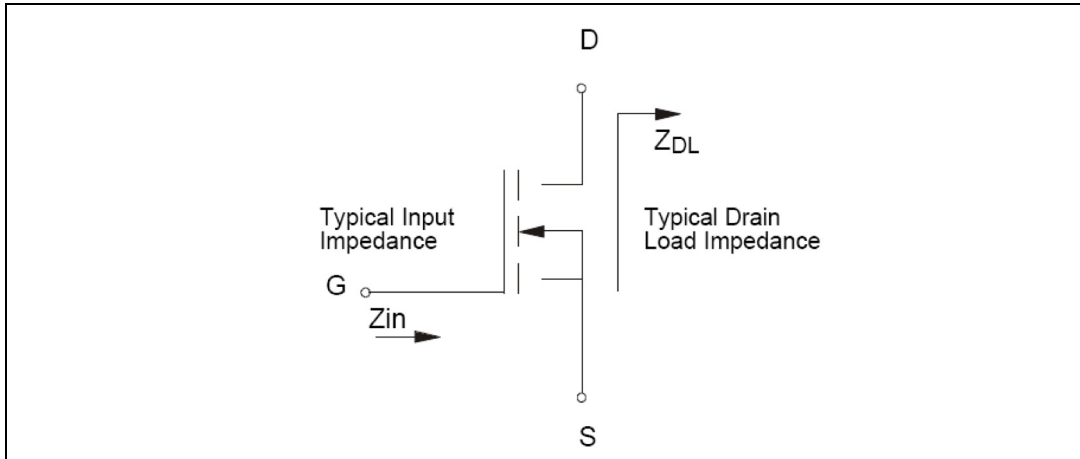

Table 6. Impedance data

Freq. (MHz)	$Z_{IN} (\Omega)$	$Z_{DL}(\Omega)$
175 MHz	$2.0 - j2.0$	$3.5 + j5.2$

Note: Measured gate to gate and drain to drain, respectively.

4 Typical performance

www.datasheet4u.com

Figure 3. Capacitances vs drain supply voltage

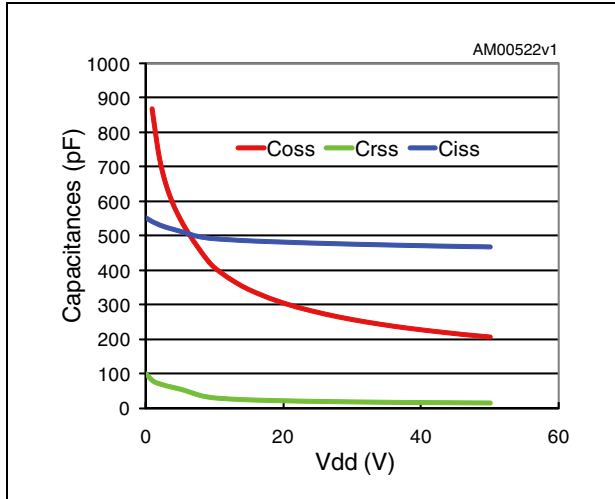

Figure 4. Output power vs drain supply voltage

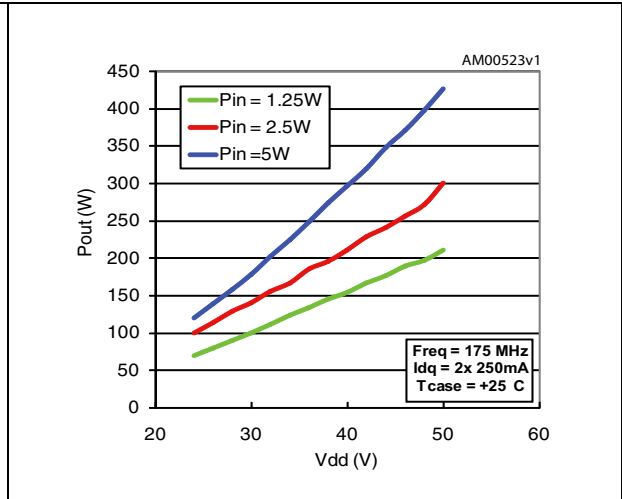

Figure 5. Output power vs gate voltage

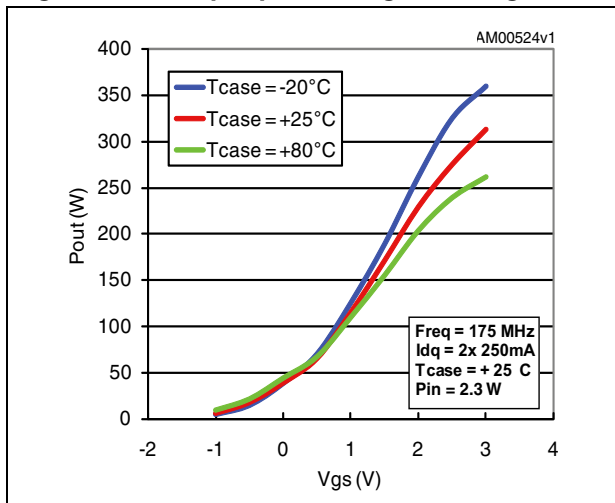

Figure 6. Output power vs input power

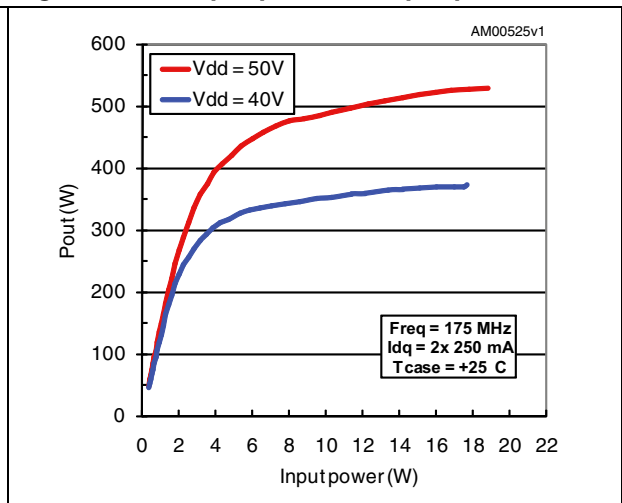

Figure 7. Output power vs input power and case temperature

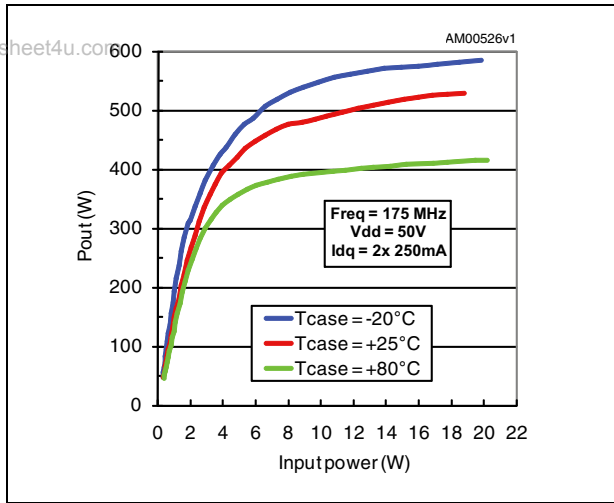
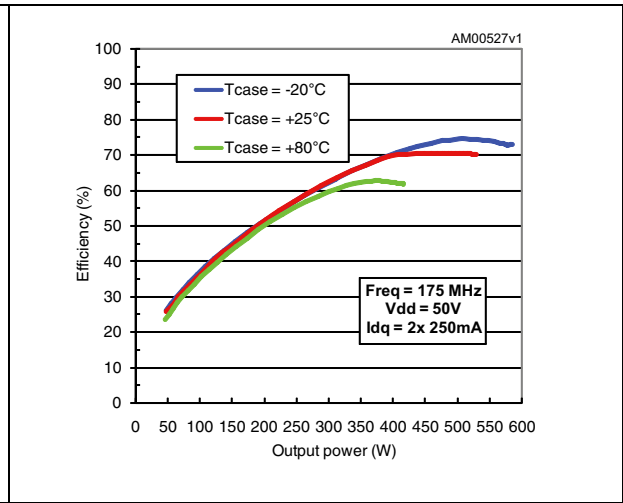

Figure 8. Efficiency vs output power and case temperature



5 Test circuit

Figure 9. 175 MHz test circuit schematic (production test circuit)

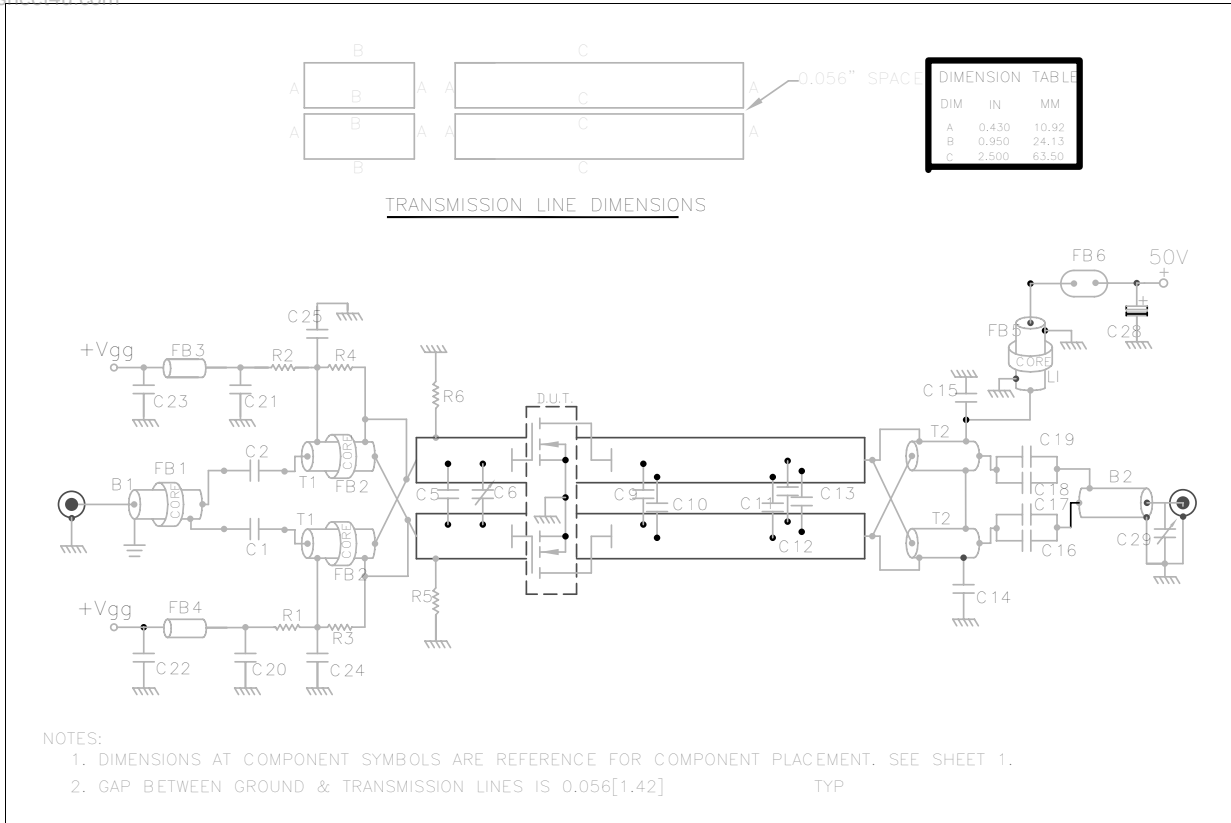

Table 7. 175 MHz test circuit component part list

Component	Description
C1, C2, C14, C15, C24, C25	1200 pF ATC 700B chip capacitor
C5	75 pF ATC 100B chip capacitor
C6	ST406 variable capacitor
C9, C10	47 pF ATC 100B chip capacitor
C11, C12, C13	43 pF ATC 100B chip capacitor
C16, C18	470 pF ATC 100B chip capacitor
C17, C19, C20, C21	10,000 pF ATC 200B chip capacitor
C22, C23	0.1 μF 200 V chip capacitor
C28	10 μF 100 V electrolytic capacitor
C29	0.8 - 8 pF variable capacitor
R1, R2, R5, R6	430 Ω, 1/2 W chip resistor

Table 7. 175 MHz test circuit component part list (continued)

Component	Description
R3, R4	270 Ω 1/2 W axial lead resistor
B1	RG-316 50 Ω 11.8" thru ferrite toroidal
B2	RG-142 50 Ω 11.8"
T1	4:1, RG-316 25 Ω, 5.9", 2 turns thru ferrite core
T2	1:4, 25 Ω semi-rigid cable, OD.141", 5.9"
L1	λ/4 inductor, RG-142 50 Ω, 11.8", 3 turns thru ferrite toroid
FB1,FB5	ferrite toroidal
FB2, FB6	multi-aperture core
FB3, FB4	surface mount ferrite bead
PCB	Rogers ultralam 2000, Er 2.55, 0.060"

Figure 10. Circuit layout

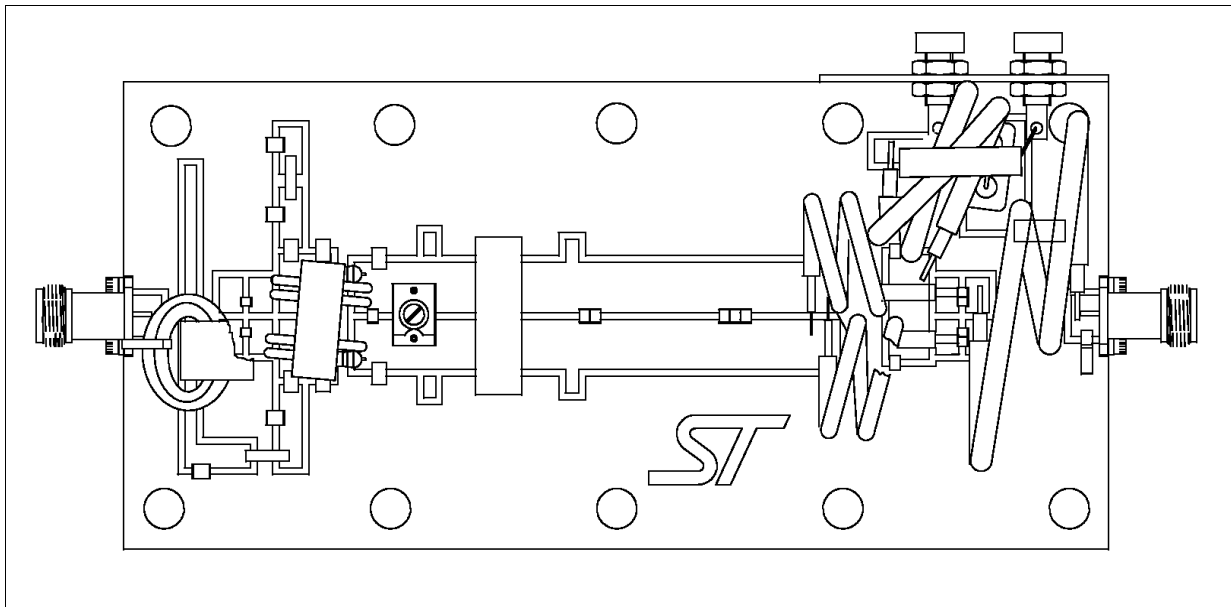

6 Package mechanical data

www.datasheet4u.com

In order to meet environmental requirements, ST offers these devices in different grades of ECOPACK® packages, depending on their level of environmental compliance. ECOPACK® specifications, grade definitions and product status are available at: www.st.com. ECOPACK is an ST trademark.

Table 8. STAC244B package dimensions

Dim.	mm.			Inch		
	Min	Typ	Max	Min	Typ	Max
A		5.33			0.210	
B		4.83			0.190	
C1		3.25			0.128	
C2		7.24			0.285	
C3		6.22			0.245	
D		9.78			0.385	
E		19.43			0.765	
F1		9.91			0.390	
F2		4.57			0.180	
F3		15.24			0.600	
G1		27.94			1.100	
G2		25.10			0.988	
G3		28.75			1.132	
G4		5.08			0.200	
H1		34.04			1.340	
H2		20.96			0.825	
I		0.15			0.006	
J		1.02			0.040	
K		1.57			0.062	
L1		5.21			0.205	
L2		5.33			0.210	
L3		3.25			0.128	
M		9.14			0.360	
N		17.91			0.705	
Controlling dimension: inches						

Figure 11. Package dimensions

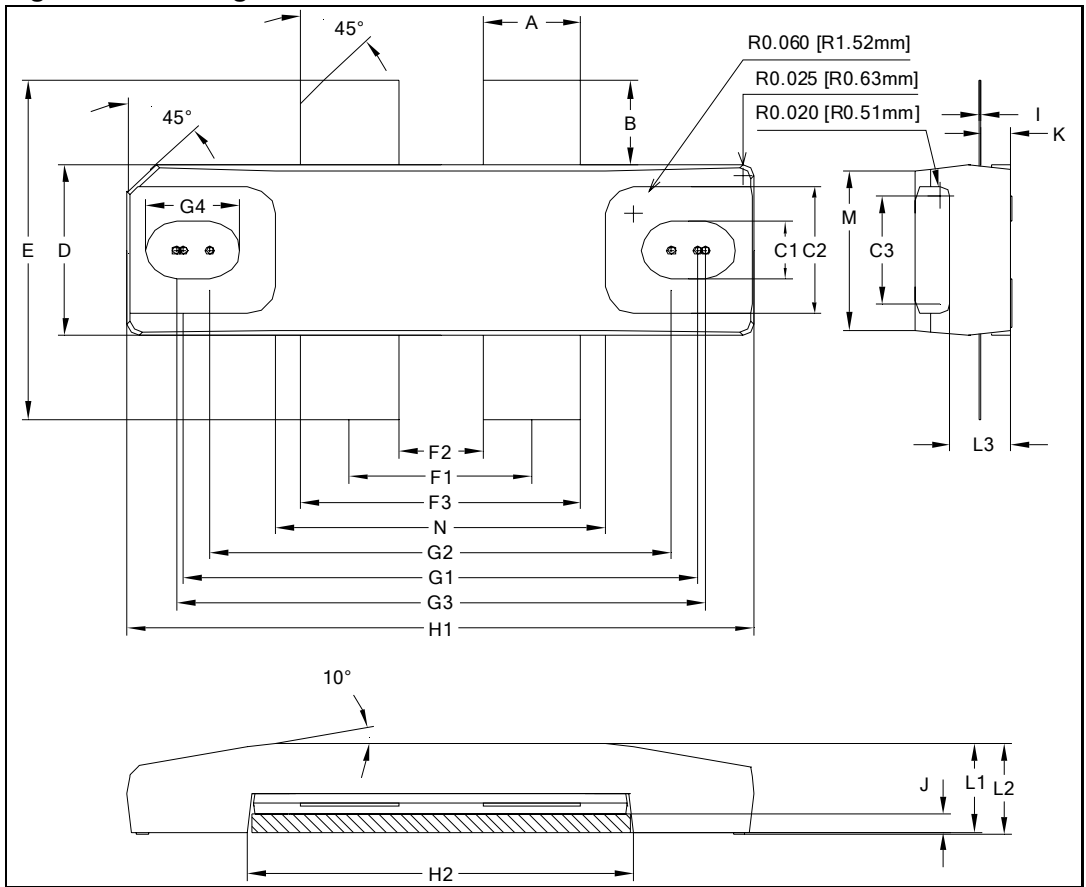

7 Revision history

www.datasheet4u.com

Table 9. Document revision history

Date	Revision	Changes
20-Mar-2009	1	First release

Please Read Carefully:

Information in this document is provided solely in connection with ST products. STMicroelectronics NV and its subsidiaries ("ST") reserve the right to make changes, corrections, modifications or improvements, to this document, and the products and services described herein at any time, without notice.

All ST products are sold pursuant to ST's terms and conditions of sale.

Purchasers are solely responsible for the choice, selection and use of the ST products and services described herein, and ST assumes no liability whatsoever relating to the choice, selection or use of the ST products and services described herein.

No license, express or implied, by estoppel or otherwise, to any intellectual property rights is granted under this document. If any part of this document refers to any third party products or services it shall not be deemed a license grant by ST for the use of such third party products or services, or any intellectual property contained therein or considered as a warranty covering the use in any manner whatsoever of such third party products or services or any intellectual property contained therein.

UNLESS OTHERWISE SET FORTH IN ST'S TERMS AND CONDITIONS OF SALE ST DISCLAIMS ANY EXPRESS OR IMPLIED WARRANTY WITH RESPECT TO THE USE AND/OR SALE OF ST PRODUCTS INCLUDING WITHOUT LIMITATION IMPLIED WARRANTIES OF MERCHANTABILITY, FITNESS FOR A PARTICULAR PURPOSE (AND THEIR EQUIVALENTS UNDER THE LAWS OF ANY JURISDICTION), OR INFRINGEMENT OF ANY PATENT, COPYRIGHT OR OTHER INTELLECTUAL PROPERTY RIGHT.

UNLESS EXPRESSLY APPROVED IN WRITING BY AN AUTHORIZED ST REPRESENTATIVE, ST PRODUCTS ARE NOT RECOMMENDED, AUTHORIZED OR WARRANTED FOR USE IN MILITARY, AIR CRAFT, SPACE, LIFE SAVING, OR LIFE SUSTAINING APPLICATIONS, NOR IN PRODUCTS OR SYSTEMS WHERE FAILURE OR MALFUNCTION MAY RESULT IN PERSONAL INJURY, DEATH, OR SEVERE PROPERTY OR ENVIRONMENTAL DAMAGE. ST PRODUCTS WHICH ARE NOT SPECIFIED AS "AUTOMOTIVE GRADE" MAY ONLY BE USED IN AUTOMOTIVE APPLICATIONS AT USER'S OWN RISK.

Resale of ST products with provisions different from the statements and/or technical features set forth in this document shall immediately void any warranty granted by ST for the ST product or service described herein and shall not create or extend in any manner whatsoever, any liability of ST.

ST and the ST logo are trademarks or registered trademarks of ST in various countries.

Information in this document supersedes and replaces all information previously supplied.

The ST logo is a registered trademark of STMicroelectronics. All other names are the property of their respective owners.

© 2009 STMicroelectronics - All rights reserved

STMicroelectronics group of companies

Australia - Belgium - Brazil - Canada - China - Czech Republic - Finland - France - Germany - Hong Kong - India - Israel - Italy - Japan - Malaysia - Malta - Morocco - Singapore - Spain - Sweden - Switzerland - United Kingdom - United States of America

www.st.com

