



# START499

## NPN Silicon RF Transistor

- HIGH EFFICIENCY
- HIGH GAIN
- LINEAR AND NON LINEAR OPERATION
- TRANSITION FREQUENCY 42GHz
- ULTRA MINIATURE SOT343 (SC70) PACKAGE

### DESCRIPTION

START499 is a product of the START family that provide the market with a Si state-of-art RF process. Manufactured in St 3rd generation bipolar process, it offers the highest power, gain and efficiency in SOT343 for given breakdown voltage ( $V_{ce0}$ ). Suitable for a wide range of applications up to 5GHz, it shows a performance level achieved before with GaAs products only.

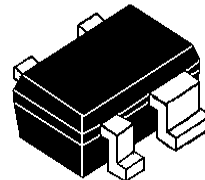

SOT343 (SC70)

**ORDER CODE**  
START499TR

**BRANDING**  
499

### APPLICATIONS

- PA FOR DECT OR PHS
- PA STAGE FOR WIRELESS LAN AND BLUETOOTH @ 2.5GHz
- UHF-VHF PRE POWER AMPLIFIER

### ABSOLUTE MAXIMUM RATINGS

Symbol	Parameter	Value	Unit
$V_{ce0}$	Collector emitter voltage	4.5	V
$V_{cbo}$	Collector base voltage	15	V
$V_{ebo}$	Emitter base voltage	1.5	V
$I_c$	Collector current	600	mA
$I_b$	Base current	32	mA
$P_{tot}$	Total dissipation at $T_S = 60\text{ }^\circ\text{C}$	600	mW
$T_{stg}$	Storage temperature	-65 to 150	$^\circ\text{C}$
$T_j$	Max. operating junction temperature	150	$^\circ\text{C}$

### ABSOLUTE MAXIMUM RATINGS

$R_{thjs}$	Thermal Resistance Junction soldering point	150	$^\circ\text{C}/\text{W}$
------------	---	-----	---------------------------

**ELECTRICAL CHARACTERISTICS** ( $T_j=25\text{ }^\circ\text{C}$ , unless otherwise specified)

Symbol	Parameter	Test Conditions	Min.	Typ.	Max.	Unit
$I_{cbo}$	Collector cutoff current	$V_{cb} = 5V, I_e = 0A$			1.2	$\mu A$
$I_{ebo}$	Emitter-base cutoff current	$V_{eb} = 1.5V, I_c = 0A$			120	$\mu A$
Hfe	DC current gain	$I_c = 160mA, V_{ce} = 4V$		160		
G	Power gain	$I_c = 200mA, V_{ce} = 3V, f = 1.8GHz$		15		dB
P <sub>-1dB</sub>	1 dB compression point	$I_c = 200mA, V_{ce} = 3V, f = 1.8GHz$		23.5		dBm
IP3	Ouput third order intercept point	$I_c = 200mA, V_{ce} = 3V, f = 1.8GHz$		33.5		dBm
NF	Noise Figure	$I_c = 200mA, V_{ce} = 3V, f = 1.8GHz$		3.3		dB

**QUICK REFERENCE DATA**

MODE OF OPERATION	f (GHz)	V <sub>CE</sub> (V)	P <sub>L</sub> (dBm)	G <sub>p</sub> (dB)	$\eta$ (%)
Class-AB ( $I_{cq} = 5mA$ )	1.9	3.6	26	$\geq 12$	typ. 68

**PINOUT**

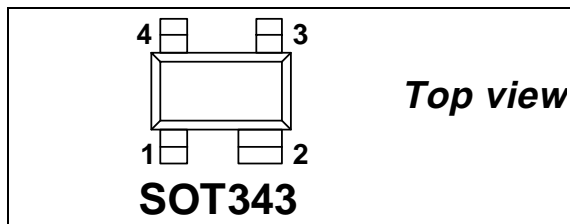

**PIN CONNECTION**

Pin No.	Description
1	BASE
3	COLLECTOR
2,4	EMITTER

**SPICE PARAMETERS (Gummel-Poon Model, Berkley-SPICE 2G.6 Syntax)**

**TRANSISTOR CHIP DATA**

Symbol	Value	Symbol	Value	Symbol	Value
TMEAS	27.0	FC	0.81	XJBC	0.51
IS	3.27E-16	EG	1.12	XTI	3.68
ISE	13.08E-12	NF	1	BF	332
NR	1	NE	3.2	VAF	70
ISC	7.89E-15	BR	9.75	VAR	2.1
IKF	{3.948*((T(°C)+273.15)/300.15)^(-1.7)}	NC	1.5	TF	3.4E-12
TR	7E-10	PTF	38	VTF	29.7
XTF	16.3	ITF	5.01	MJE	0.341
RB	2.58	RBM	0.83	MJC	0.312
RC	0.597	RE	0.066	MJS	0.297
CJE	3048E-15	VJE	1.09	IKR	57.3E-3
CJC	930E-15	VJC	0.695	XTB	-0.82
CJS	510E-15	VJS	0.507		

**PACKAGE EQUIVALENT CIRCUIT**

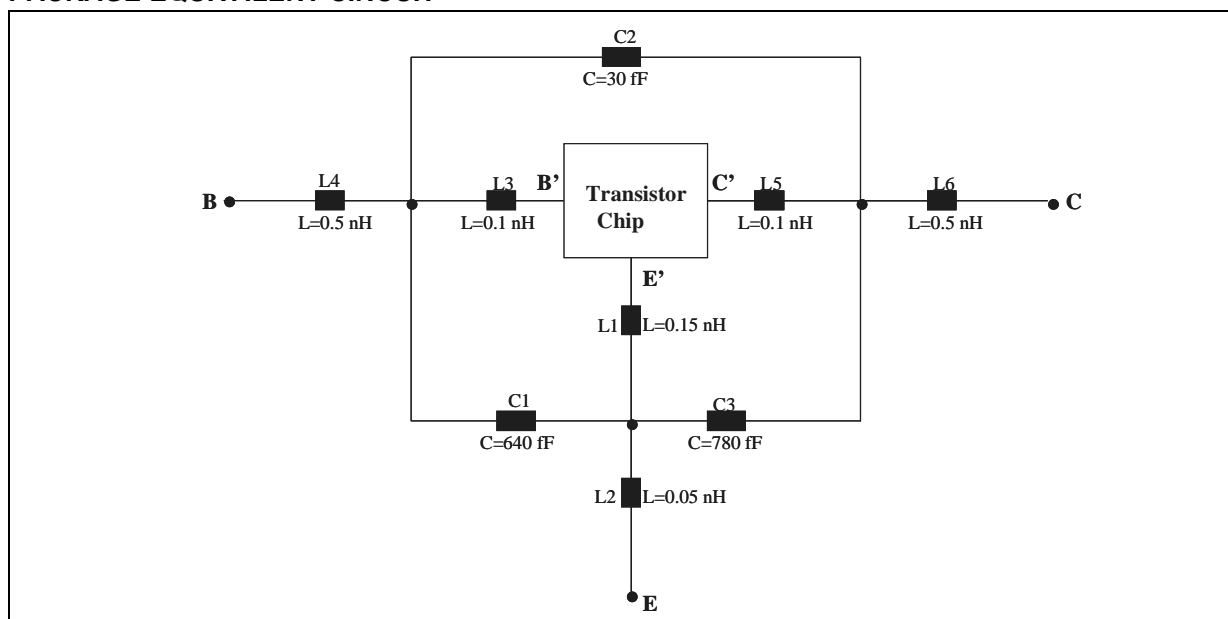

In order to avoid high complexity of the package equivalent circuit, the two emitter leads of SOT-343 package are combined in one electrical connection.

**FOR MORE ACCURACY SIMULATION IN SATURATION REGION :**

Adding the 5 Spice parameters showed in Table A and using **ST Spice Library** (available on request) you can achieve a more accuracy simulation in the saturation region. ST Spice library is compatible with following simulators: ELDO MENTOR (any version), SPECTRE CADENCE (any version), ADS (version 2001 only).

**Table A (Spice Parameters extracted in saturation region)**

RW	Vjj	ENP	VRP	RP
1.034	0.755	2.235	{7.2*((TEMPER+273.15)/300.15)^(0.125)}	0.33E-6

**START499****COMMON EMITTER S-PARAMETERS (  $V_{CE} = 2V$ ,  $I_C = 200mA$  )**

FREQ (MHz)	$ S_{11} $	$S_{11}\angle\Phi$	$ S_{21} $	$S_{21}\angle\Phi$	$ S_{12} $	$S_{12}\angle\Phi$	$ S_{22} $	$S_{22}\angle\Phi$
0.1	0.669	-158	65.164	124	0.008	47	0.635	-107
0.5	0.778	-179	15.773	105	0.013	81	0.589	-164
0.9	0.781	174	8.622	107	0.021	119	0.600	-174
1	0.780	173	7.535	109	0.021	134	0.598	-176
1.5	0.782	167	5.203	120	0.061	160	0.600	180
1.8	0.764	162	4.229	122	0.062	171	0.605	177
2	0.765	159	3.896	125	0.090	173	0.600	176
2.5	0.725	153	3.150	131	0.132	179	0.590	174
3	0.687	148	2.364	138	0.152	170	0.575	171
3.5	0.662	142	1.806	152	0.211	161	0.569	167
4	0.677	139	1.558	165	0.263	154	0.586	162

TAPE & REEL DIMENSIONS

	mm		
	MIN.	TYP.	MAX
A	178.5	179	179.5
C	12.8	13.0	13.5
D	20.2		
N	54.5	55	55.5
T			14.4
Ao		2.25	
Bo		2.7	
Ko		1.2	
Po	3.8 (cumulative 10 Po)	4.0	4.2 (cumulative 10 Po)
P		4.0	

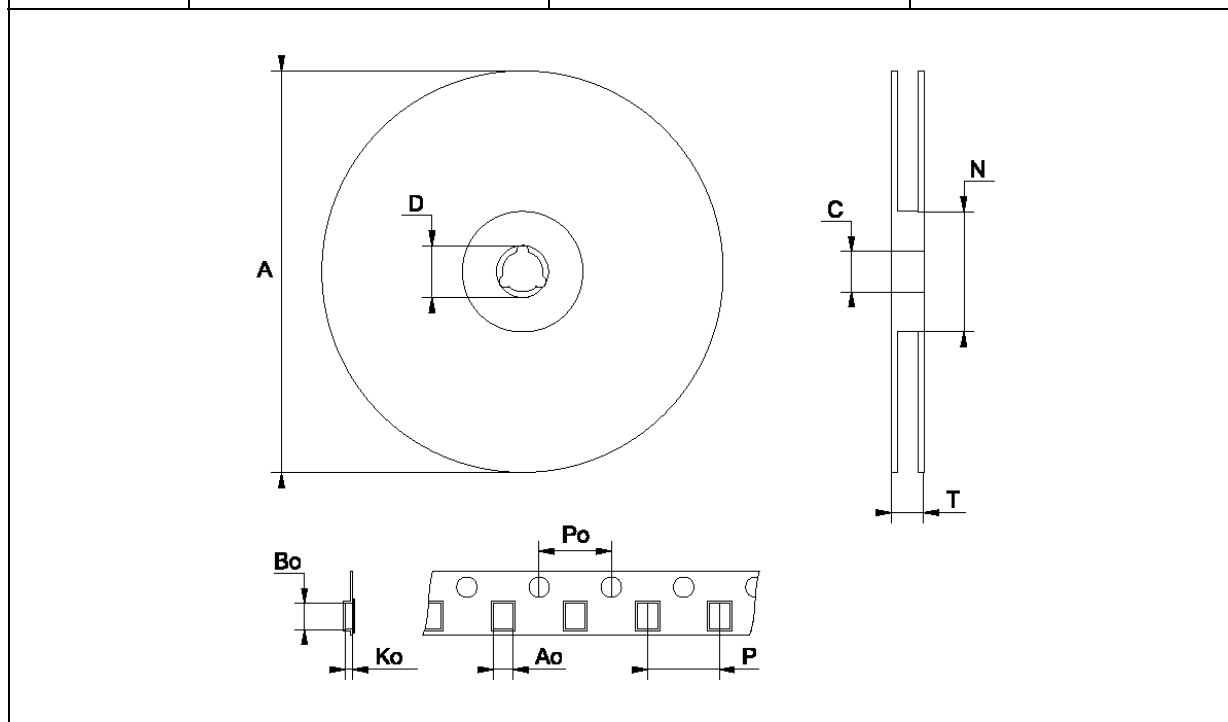

DEVICE ORIENTATION

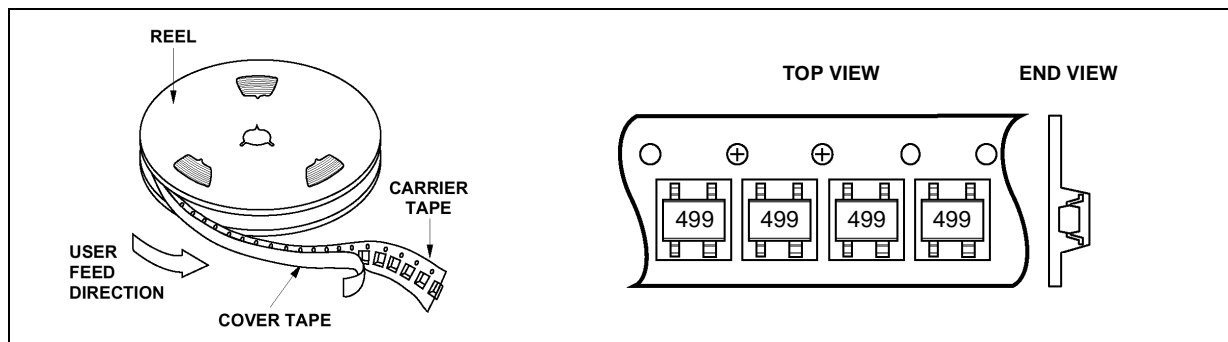

PACKAGE DIMENSIONS SOT343 (SC-70 4 leads)

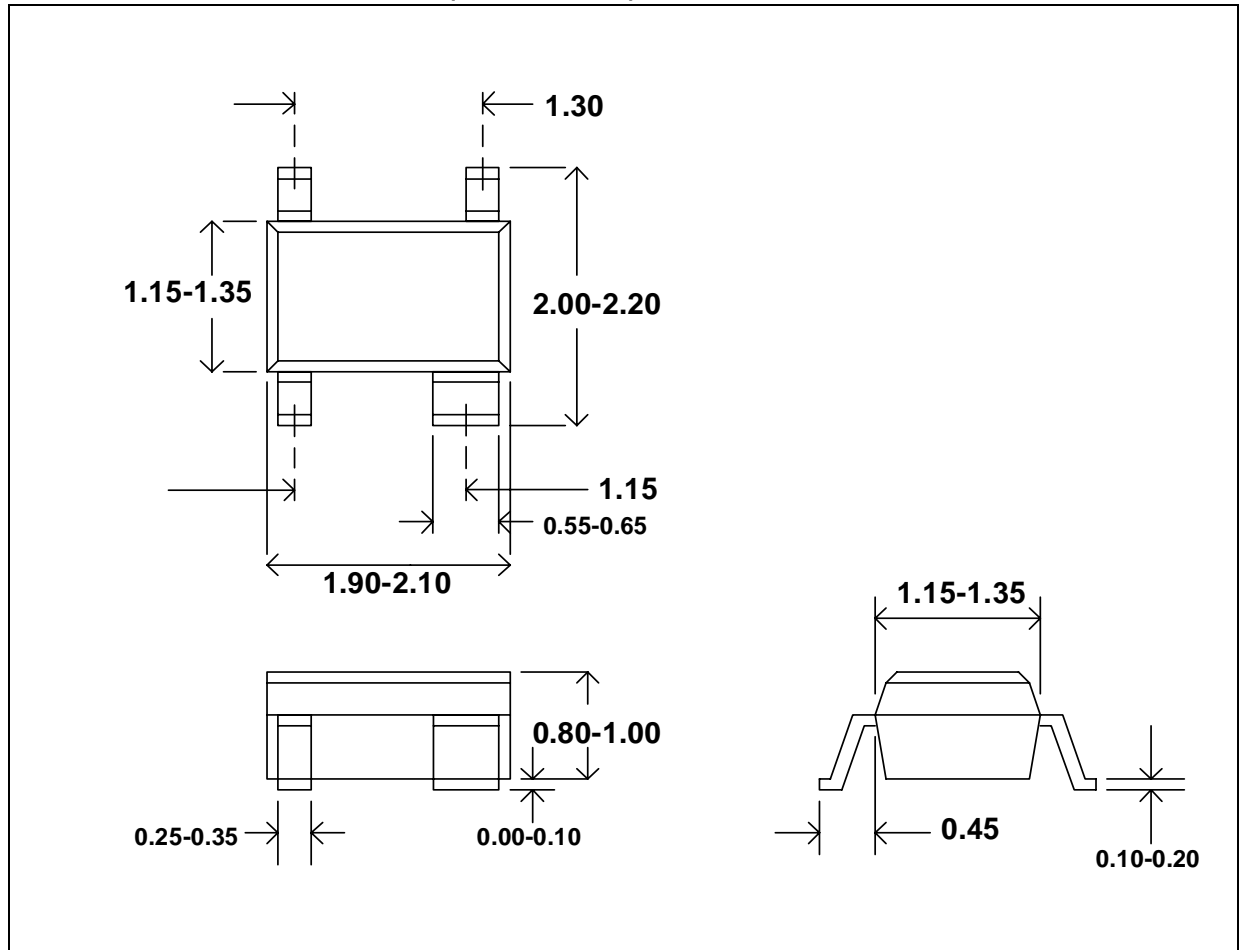

Information furnished is believed to be accurate and reliable. However, STMicroelectronics assumes no responsibility for the consequences of use of such information nor for any infringement of patents or other rights of third parties which may result from its use. No license is granted by implication or otherwise under any patent or patent rights of STMicroelectronics. Specifications mentioned in this publication are subject to change without notice. This publication supersedes and replaces all information previously supplied. STMicroelectronics products are not authorized for use as critical components in life support devices or systems without express written approval of STMicroelectronics.

The ST logo is registered trademark of STMicroelectronics  
© 2002 STMicroelectronics - All Rights Reserved

All other names are the property of their respective owners.

STMicroelectronics GROUP OF COMPANIES  
Australia - Brazil - Canada - China - Finland - France - Germany - Hong Kong - India - Israel - Italy - Japan -  
Malaysia - Malta - Morocco - Singapore - Spain - Sweden - Switzerland - United Kingdom - U.S.A.  
<http://www.st.com>