

Features

- Power Transistor General Purpose application
- Low saturation voltage
: $V_{CE(SAT)}=0.4V$ Max.
- High Voltage : $V_{CEO}=60V$ Min.

Ordering Information

Type NO.	Marking	Package Code
STC403D	STC403	D-PAK

Outline Dimensions

unit : mm

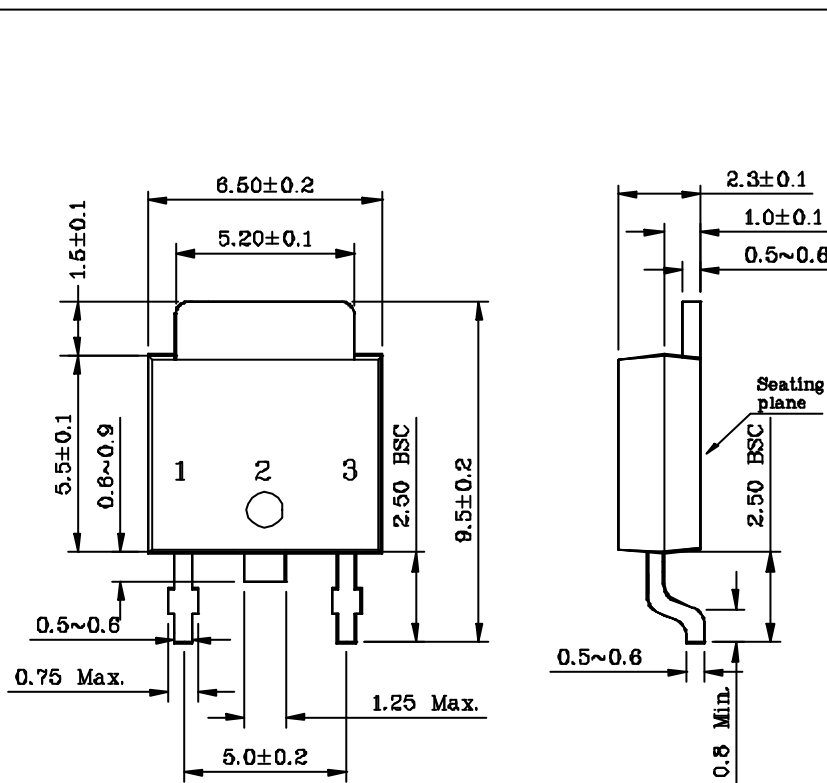

PIN Connections

1. Base
2. Collector
3. Emitter

Absolute maximum ratings

Characteristic	Symbol	Ratings	Unit
Collector-Base voltage	V_{CBO}	80	V
Collector-Emitter voltage	V_{CEO}	60	V
Emitter-base voltage	V_{EBO}	5	V
Collector current	I_C	3	A
Collector dissipation ($T_c=25^\circ$)	P_C	15	W
Junction temperature	T_J	150	$^\circ\text{C}$
Storage temperature	T_{stg}	-55~150	$^\circ\text{C}$

Electrical Characteristics

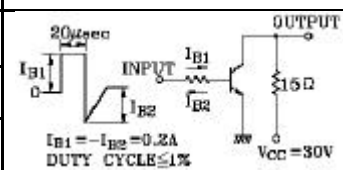
Characteristic	Symbol	Test Condition	Min.	Typ.	Max.	Unit			
Collector-Emitter breakdown voltage	BV_{CEO}	$I_C=50\text{mA}, I_B=0$	60	-	-	V			
Collector cut-off current	I_{CBO}	$V_{CB}=60\text{V}, I_E=0$	-	-	50	μA			
Emitter cut-off current	I_{EBO}	$V_{EB}=5\text{V}, I_C=0$	-	-	50	μA			
DC current gain	h_{FE}^*	$V_{CE}=5\text{V}, I_C=0.5\text{A}$	200	-	400	-			
Base-Emitter on voltage	$V_{BE(ON)}$	$V_{CE}=5\text{V}, I_C=0.5\text{A}$	-	0.7	1	V			
Collector-Emitter saturation voltage	$V_{CE(sat)}$	$I_C=2\text{A}, I_B=0.2\text{A}$	-	0.4	1	V			
Transition frequency	f_T	$V_{CB}=5\text{V}, I_C=0.5\text{A}$	-	30	-	MH			
Collector output capacitance	C_{ob}	$V_{CB}=10\text{V}, I_E=0, f=1\text{MHz}$	-	35	-	pF			
Switching Time	Turn-on Time	T_{on}				-	0.65	-	μs
	Storage Time	T_{stg}	-	1.3	-				
	Fall Time	T_f	-	0.65	-				

* HFE rank : 200~400 Only

Electrical Characteristic Curves

Fig. 1 $P_C - T_a$

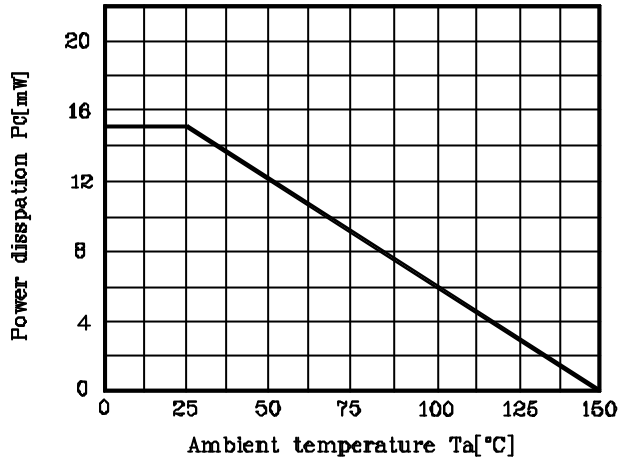

Fig. 2 $V_{CE} - I_C$

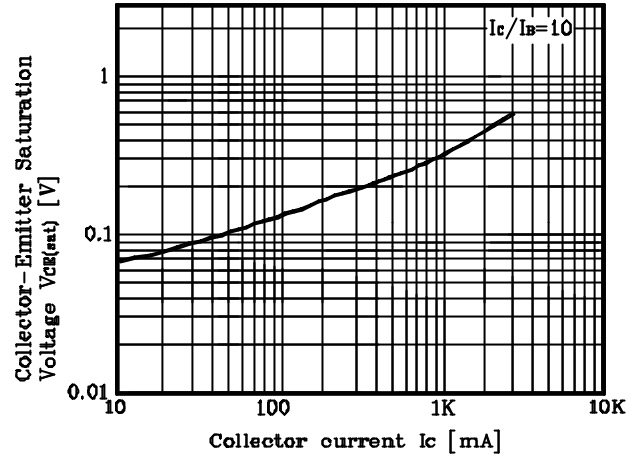

Fig. 3 $h_{FE} - I_C$

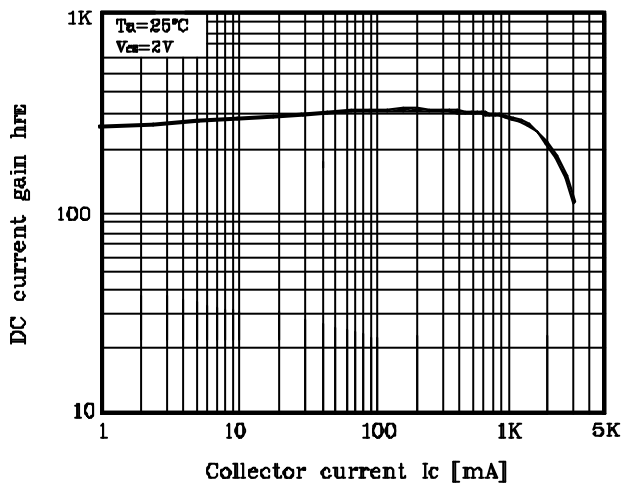

Fig. 5 $I_C - V_{CE}$

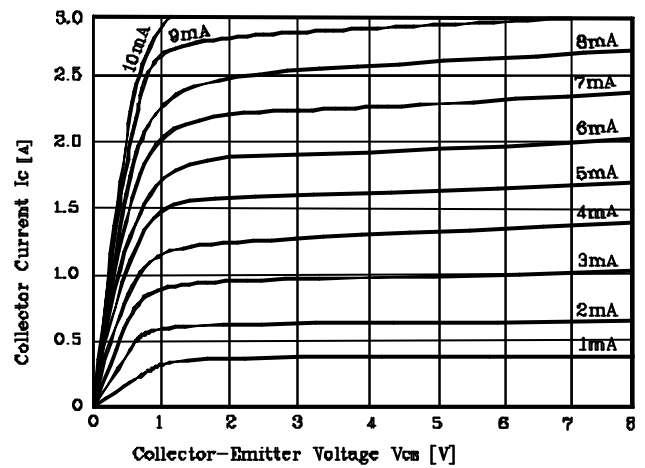

Fig. 5 Safe operating Area

