

150KHz, 2A Buck DC/DC Converter

PWM Control Step-Down DC/DC Converter

DESCRIPTION

The STD1501 series of regulators are monolithic integrated circuits that provide all the active functions for a step-down (buck) switching regulator, capable of driving a 2A load with excellent line and load regulation. These devices are available in fixed output voltage of 3.3V and 5V an adjustable output version.

The STD1501 operates at a switching frequency of 150KHz thus allowing smaller sized filter components than what would be needed with lower frequency switching regulators.

Other features include a guaranteed $\pm 3\%$ tolerance on output voltage under specified input voltage and output load conditions, and $\pm 15\%$ on the oscillator frequency. External shutdown is included, featuring typically 100 μ A standby current.

STD1501-XXD-TRG ROHS Compliant This is Halogen Free

FEATURE

- ◆ 3.3V, 5V, 12V and adjustable output versions
- ◆ Adjustable version output voltage range 1.23V to 36V
- ◆ Input voltage range up to 40V
- ◆ Guaranteed 2A output current
- ◆ TTL shutdown capability
- ◆ 150KHz fixed frequency internal oscillator
- ◆ Built-in thermal shutdown and current limit protection
- ◆ This is a Full RoHS compliance
- ◆ SOP-8 package design

APPLICATIONS

- ◆ Fixed voltage power supply for LCD monitor and LCD TV
- ◆ On-Card switching regulation
- ◆ Simple high efficiency Step-down regulator



PIN CONFIGURATION

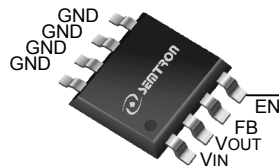

SOP-8
Top View

PART MARKING INFORMATION

<p>STD 1501- XX M TR G</p> <p>a b c d e f</p>	<p>a : Company name.</p> <p>b : Product Serial number.</p> <p>c : Voltage Code.</p> <p style="margin-left: 40px;">XX</p> <p style="margin-left: 40px;">33 : 3.3V, 50 : 5.0V, ADJ : ADJ</p> <p>d : Package code.</p> <p>e : Handling code.</p> <p>f : Green produce code.</p>
---	--

ORDERING INFORMATION

Part Number	Package Code	Package	VO _{UT} Voltage	Shipping
STD1501-XXM-TRG	M	SOP-8	ADJ 3.3 5.0	2500/Tape&Reel

Note:

- ※“XX”stands for output voltages.
- ※ Year Code : 0 ~ 9
- ※Week Code : A ~ Z(1~26) ; a ~ z(27~52)
- ※ SOP-8 : Only available in tape and reel packaging. (A reel contains 2500 devices)
- ※ G : Lead-free product. This product is RoHS compliant.

BLOCK DIAGRAM

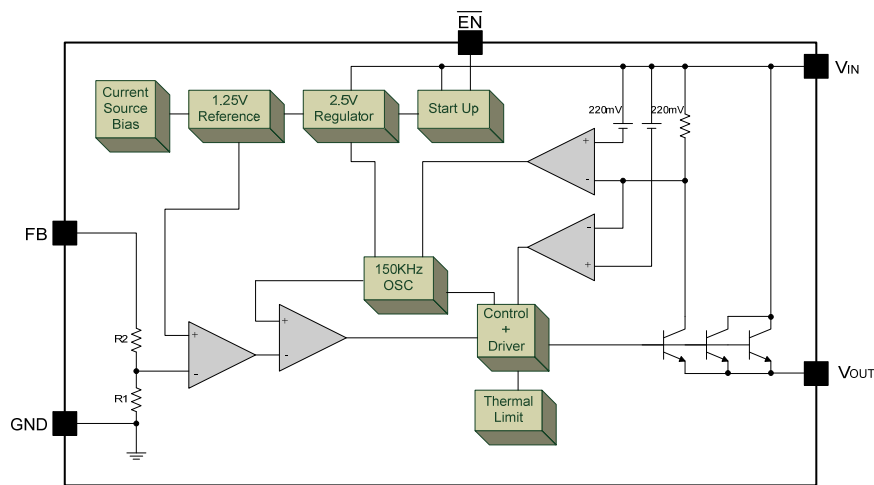

ABSOLUTE MAXIMUM RATINGS (T_A = 25°C Unless otherwise noted)

Parameter	Symbol	Maximum	Unit
Power Dissipation	P _D	Internally Limited	W
Maximum Supply Voltage	V _{IN}	40	V
$\overline{\text{EN}}$ Pin Input Voltage	$\overline{\text{EN}}$	-0.3V < V < + V _{IN}	V
Thermal resistance junction to Case	θ _{JT}	3.0	°C /W
Thermal resistance junction to Ambient	θ _{JA}	36	°C /W
Operating Junction Temperature Range	T _J	-40~+125	°C
Storage Temperature Range	T _{STG}	-65~+150	°C
Minimum EDS Rating	ESD	2	KV
Lead Soldering Temperature (Soldering, 10 sec)	T _{LEAD}	260	°C

Note: Exceeding these ratings could cause damage to the device. All voltages are with respect to Ground. Currents are positive into, negative out of the specified terminal.

θ_{JA} : Thermal Resistance-Junction to Ambient, Junction Temperature Calculation: T_J = T_A + (P_D × θ_{JA})

The θ_{JA} numbers are guidelines for the thermal performance of the device/PC-board system.

All of the above assume no ambient airflow.

θ_{JT} : Thermal Resistance-Junction to Ambient,

ELECTRICAL CHARACTERISTICS ($T_A = 25^\circ\text{C}$ Unless otherwise noted)

Unless otherwise specified, these specifications apply $V_{IN} = 12\text{V}$ for 3.3V and 5.0V options, and $V_{IN} = 24\text{V}$ for Adj option, and the operating ambient temperatures $T_A = 25^\circ\text{C}$

Parameter		Symbol	Test Conditions	Min	Typ	Max	Unit
Output Voltage (Note 1)	STD1501-ADJ	V_{OUT}	$4.5\text{V} \leq V_{IN} \leq 38\text{V}$ $0.2\text{A} \leq I_{OUT} \leq 2\text{A}$ $V_{OUT} = 3\text{V}$	1.193	1.230	1.267	V
	STD1501-3.3		$4.75\text{V} \leq V_{IN} \leq 38\text{V}$ $0.2\text{A} \leq I_{OUT} \leq 2\text{A}$	3.200	3.300	3.400	
	STD1501-5.0		$7\text{V} \leq V_{IN} \leq 38\text{V}$ $0.2\text{A} \leq I_{OUT} \leq 2\text{A}$	4.850	5.000	5.150	
Efficiency	STD1501-ADJ	η	$V_{IN} = 12\text{V}$, $I_{LOAD} = 2\text{A}$, $V_{OUT}=3\text{V}$	-	90	-	%
	STD1501-3.3		$V_{IN} = 12\text{V}$, $I_{LOAD} = 2\text{A}$	-	73	-	
	STD1501-5.0		$V_{IN} = 12\text{V}$, $I_{LOAD} = 2\text{A}$	-	80	-	
Feedback Bias Current		I_B	$V_{FB}=1.3\text{V}$ (Adjustable Version Only)	-	10	50	nA
Saturation Voltage		V_{SAT}	$I_{out}=2\text{A}$, (Note 1, 2)	-	1.16	1.4	V
Duty Cycle (ON)		DC	(Note 2)	-	100	-	%
Duty Cycle (OFF)		DC	(Note 3)	-	0	-	%
Oscillator Frequency		f_o	(Note 4)	127	150	173	KHz
Output Leakage Current	I_L	Output=0V, (Note 1, 3,)		-	-	100	μA
		Output=-0.9V, (Note 5)		-	2	-	mA
Quiescent Current		I_Q	(Note 3)	-	5	-	mA
Standby Current		I_{STBY}	\overline{EN} Pin=5V	-	100	200	μA
\overline{EN} Pin Input Level	V_{IH}	Low (ON)		-	1.3	0.6	V
	V_{IL}	High (OFF)		2.0	1.4	-	
	I_H	$V_{LEVEL} = 2.5\text{V}$ (OFF)		-	5	15	μA
	I_L	$V_{LEVEL} = 0.5\text{V}$ (ON)			0.02	5	

NOTES: (1) No diode, inductor or capacitor connected to output pin.

(2) Feedback pin removed from output and connected to 0V to force the output transistor switch ON.

(3) Feedback pin removed from output and connected to 12V for the 3.3V and 5V and the ADJ version

(4) The switching frequency is reduced when the second stage current limit is activated.

(5) $V_{IN} = 38\text{V}$.

RECOMMENDED OPERATING CONDITIONS

Parameter	Symbol	Operating Conditions			Unit
		Min	Typ	Max	
Input Voltage	V _{IN}	-	-	38	V
Peak Current	I _{PC}	3.4	-	-	A
Maximum Load Current	I _{OUT}	-	2	-	A
Junction Temperature	T _J	-40	-	150	°C

TYPICAL APPLICATIONS

◆ Figure 1 Adjustable Output Voltage

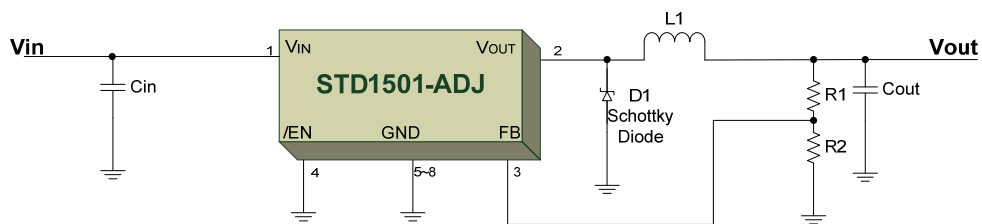

$$V_{OUT} = 1.23V \times (1 + R1/R2)$$

$C_{IN} = 100\mu F$, Aluminum Electrolytic
 $C_{OUT} = 220\mu F$, 25V, Aluminum Electrolytic
 $D1 =$ Schottky, 5A/40V
 $L1 = 33\mu H$

◆ Figure 2 Fixed Voltage Regulator:

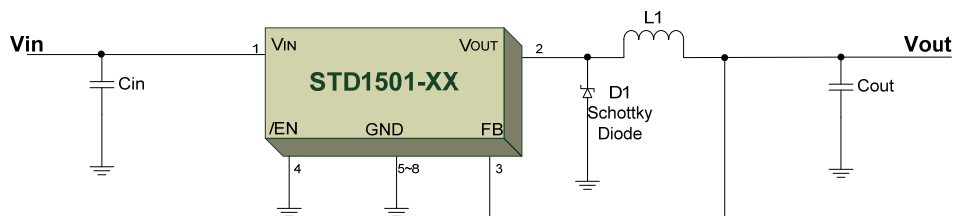

$C_{IN} = 100\mu F$, Aluminum Electrolytic
 $C_{OUT} = 220\mu F$, 25V, Aluminum Electrolytic
 $D1 =$ Schottky, 5A/40V
 $L1 = 33\mu H$

TYPICAL CHARACTERISTICS (25°C Unless Note)

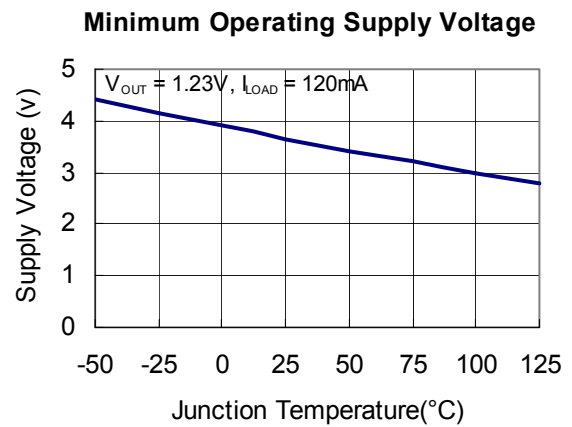
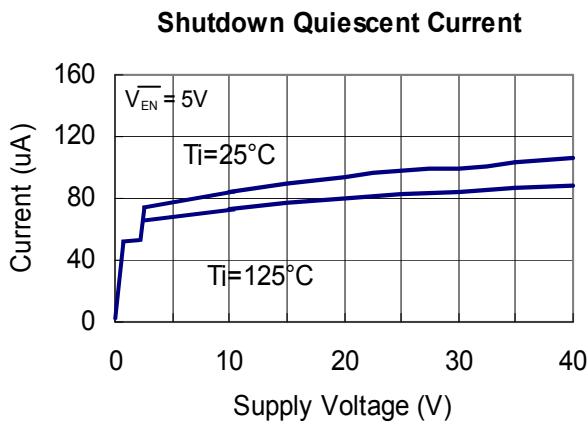
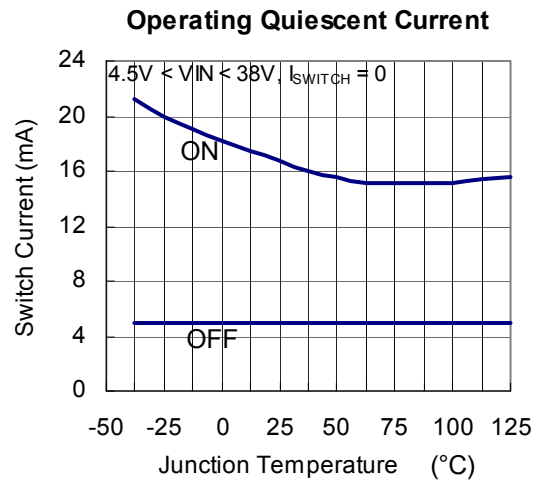
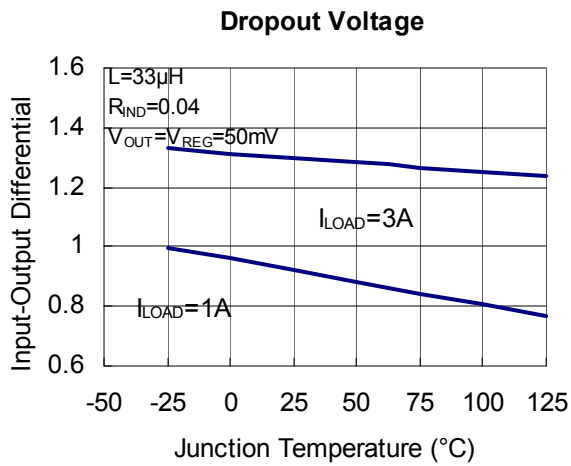
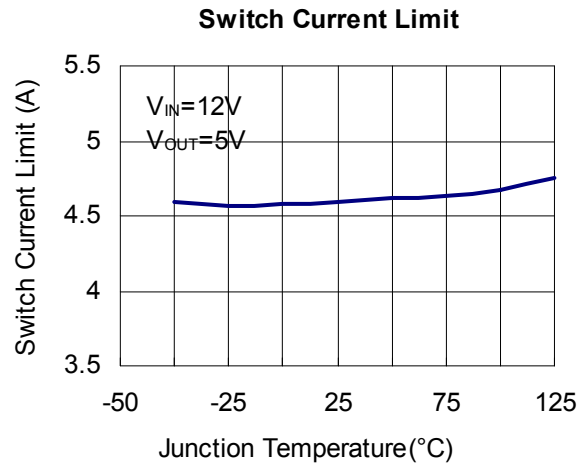
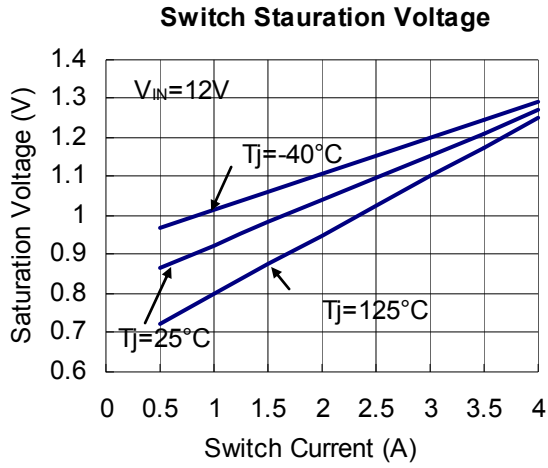

TYPICAL CHARACTERISTICS (25°C Unless Note)

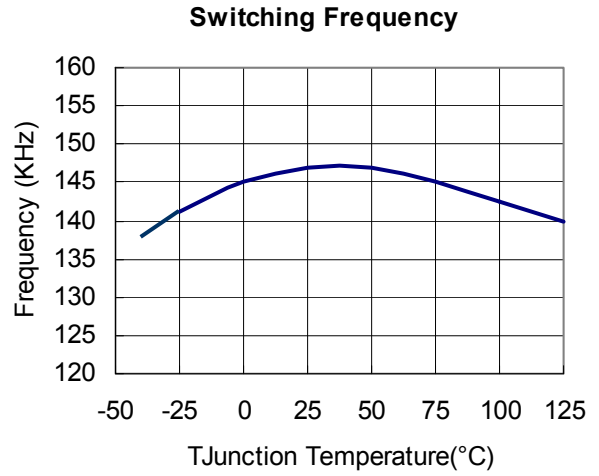
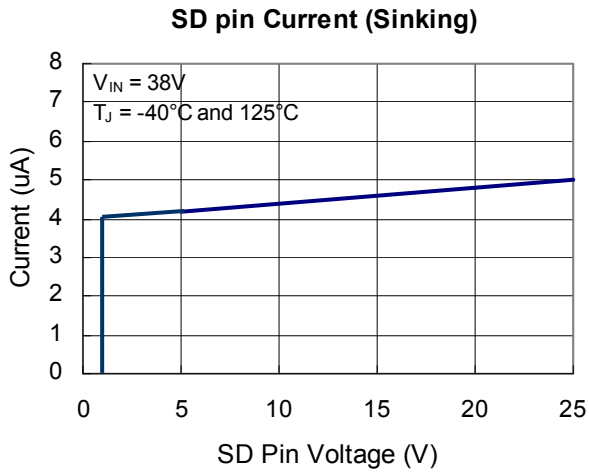

SOP-8 PACKAGE DIMENSIONS

Symbol	Dimensions In Millimeters		Dimensions In Inches	
	Min.	Max.	Min.	Max.
A	1.350	1.750	0.053	0.069
A1	0.100	0.250	0.040	0.010
A2	1.350	1.550	0.053	0.061
b	0.330	0.510	0.013	0.020
c	0.170	0.250	0.006	0.010
D	4.700	5.100	0.185	0.200
E	3.800	4.000	0.150	0.157
E1	5.800	6.200	0.228	0.244
e	1.270 BSC		0.050 BSC	
L	0.400	1.270	0.016	0.050
θ	0°	8°	0°	8°

SOP-8 PACKAGE OUTLINE DIMENSIONS

