

DisplayPort transmitter

Data brief

Features

- Enhanced DisplayPort® (DP) transmitter
 - DP 1.1a compliant
 - Embedded DisplayPort (eDP) compliant
 - 1, 2, or 4 lanes
- Higher bandwidth “Turbo mode” (3.24 Gbps) per lane, supports:
 - 1920 x 1080 (FHD) 120 Hz/10-bit color video standard timings and 7.1 Ch audio
 - 2560 x 1600 (WQXGA), 2560 x 2048 (QSXGA) 60 Hz/10-bit color graphics and 7.1 Ch audio
- Interface compatibility with wide range of display controller ICs
 - LVTTTL (60 wide) and LVDS (quad bus) video interface
 - 8-Ch I2S and SPDIF audio interface
- Robust AUX channel
 - Link service, maintenance
 - I2C-over-AUX (MCCS, DDC)
 - IR, full duplex UART protocol
- Configurable through I2C host interface
- Supports HDCP 1.3 with on-chip keys
- HDCP repeater capability
 - Acts as downstream transmitter
- Spread spectrum on DisplayPort, LVDS, and TTL interfaces for EMI reduction
- Supports deep color and color format conversion
 - RGB/YCC (4:4:4) – 10-bit color
 - YCC (4:2:2/4:2:0) – 12-bit color
 - RGB (4:4:4) to YCC (4:4:4) conversion and vice-versa
- Low power operation; 20 mW standby
- I2C to AUX bridge for EDID, MCCS pass through
- Supports HBR/“Turbo” speed over HBR/RBR-rated long cables (15 m and more)
- Package
 - 164 LFBGA (12 x 12 mm / 0.8 mm)
- Power supply voltages
 - 3.3 V I/O; 1.2 V core

Applications

- Digital TV, docking station, STB, game console, etc.

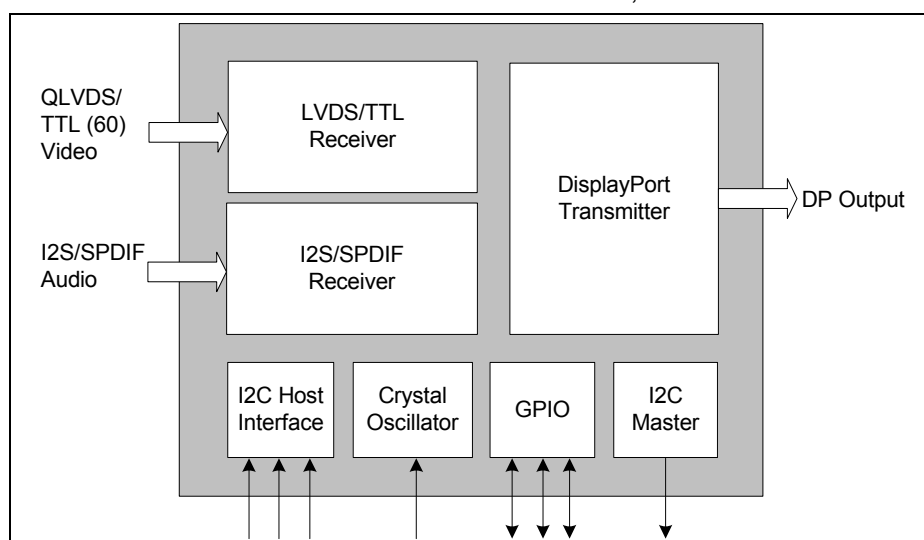

1 Description

The STDP4028 is a DisplayPort transmitter IC for the secure transmission of high-bandwidth, uncompressed digital audio-video signals targeted for applications such as DTV, LCD monitor, docking station, and other types of display systems. STDP4028 is a VESA DP 1.1a and eDP compliant device, implementing a single link DisplayPort output port comprising four main lanes, auxiliary channel and HPD. In addition to the standard HBR (2.7 Gbps) and RBR (1.62 Gbps) speeds, this device supports “turbo” speed of 3.24 Gbps per lane with a total link bandwidth of 12.96 Gbps. The higher bandwidth provides unique benefits to users over other commercial DP transmitters for embedded applications by offering additional margin to support higher color depth, resolution, and refresh rate. For example, STDP4028 supports FHD non-reduced blanking video (1080p 30-bit color per pixel) at 120 Hz, plus 7.1 Ch audio in two-box TV applications. The high-speed auxiliary channel in STDP4028 acts as a bidirectional communication link, supporting application-specific protocols such as MCCS, DDC, UART, IR, as well as, the dedicated DisplayPort link training and device management functions.

The STDP4028 supports RGB and YCC video color formats with color depth of 12 (YCC 4:2:2 only), 10, and 8 bits. This device offers LVDS and LVTTTL input interface configurable to map a wide range of display controller products. The Quad LVDS interface supports video signals up to 400 MHz pixel rate with flexible channel and lane swapping options. The 60-bit LVTTTL input ports on STDP4028 can be mapped to transfer video data either in two pixels per clock or single pixel per clock of a chosen color depth. The STDP4028 also supports both compressed and uncompressed audio formats. This device comprises four I2S audio inputs, supporting up to 8 channels LPCM audio and a single wire SPDIF input for encoded audio. The STDP4028 features HDCP 1.3 content protection scheme with an embedded key option for secure transmission of digital audio-video content. In addition, it supports the HDCP repeater function and, thus acts as a downstream transmitter suitable for two-box TV and HDMI/DVI to DP converter applications.

The STDP4028 can be configured by an external host through the I2C host interface. This IC also includes general purpose inputs/outputs that can be used for controlling system components. The STDP4028 features a color space converter (RGB to YCC and YCC to RGB) for flexible interface with external video processing devices.

Figure 1. System diagram

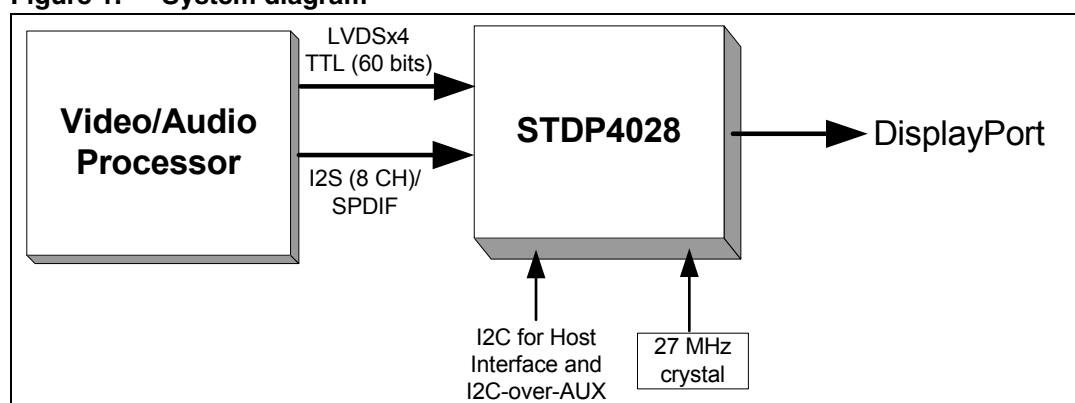

2 Benefits

- ST DP transmitter offers proven interoperability with commercial DP monitors
- 20% higher link bandwidth compared to other commercial DP transmitters, supports FHD 120 Hz/10-bit non-reduced blank timing for embedded applications
- Supports both external (DP) and embedded (eDP) applications
- HDCP repeater capability, applicable for two-box TV and HDMI/DVI to DP converters
- Embedded HDCP keys
- On-chip microprocessor enables stand-alone operation for customized applications
- Flexible interface to ease system design – DP 1, 2, 4 lane configuration, LVDS/LVTTL port, YCC/RGB color format
- Low EMI
- Low power

3 Feature attributes

- Video
 - Up to 2560 x 2048-60 Hz, 2560 x 1600-60 Hz, FHD 120 Hz at 10-bits per color
 - 8/10/12 bits per color option
 - RGB/YCC color format
- Audio
 - 8-Ch I2S; word length up to 64 x Fs; bit depth up to 32 bits, sample rate up to 192 kHz
 - SPDIF; 2-Ch LPCM, AC3, DTS, bit depth up to 24 bits, sample rate up to 192 kHz
- Input interface
 - Video: TTL 60/48 bits wide; QLVDS 8/10 per color
 - Audio: I2S 8-Ch, SPDIF x1
- Output interface
 - DP 1.1a (4 lanes, AUX, HPD); supported link speed 3.24 Gbps, 2.7 Gbps, 1.62 Gbps
- Spread spectrum
 - Supported on DP output and LVDS/TTL inputs
- AUX capabilities
 - UART, I2C-over-AUX (MCCS, DDC, etc.) IR
- HDCP
 - On-chip keys, HDCP repeater
- Color format conversion
 - RGB 4:4:4 to YCC 4:4:4 and vice-versa
- System configuration
 - I2C host interface for control by an external system microprocessor
- Package
 - 164 LFBGA (12 x 12 mm), 1 mm thickness, 0.8 pitch
- Power
 - Sub 900 mW max, 20 mW standby
- ESD
 - 2 KV HBM, 200 V MM, 750 V CDM

4 Ordering information

Table 1. Order codes

Part number	Description
STDP4028	164 LFBGA (12 x 12 mm)

In order to meet environmental requirements, ST offers these devices in different grades of ECOPACK® packages, depending on their level of environmental compliance. ECOPACK® specifications, grade definitions and product status are available at: www.st.com. ECOPACK® is an ST trademark.

5 Revision history

Table 2. Document revision history

Date	Revision	Changes
15-Sep-2010	1	Initial release.

Please Read Carefully:

Information in this document is provided solely in connection with ST products. STMicroelectronics NV and its subsidiaries ("ST") reserve the right to make changes, corrections, modifications or improvements, to this document, and the products and services described herein at any time, without notice.

All ST products are sold pursuant to ST's terms and conditions of sale.

Purchasers are solely responsible for the choice, selection and use of the ST products and services described herein, and ST assumes no liability whatsoever relating to the choice, selection or use of the ST products and services described herein.

No license, express or implied, by estoppel or otherwise, to any intellectual property rights is granted under this document. If any part of this document refers to any third party products or services it shall not be deemed a license grant by ST for the use of such third party products or services, or any intellectual property contained therein or considered as a warranty covering the use in any manner whatsoever of such third party products or services or any intellectual property contained therein.

UNLESS OTHERWISE SET FORTH IN ST'S TERMS AND CONDITIONS OF SALE ST DISCLAIMS ANY EXPRESS OR IMPLIED WARRANTY WITH RESPECT TO THE USE AND/OR SALE OF ST PRODUCTS INCLUDING WITHOUT LIMITATION IMPLIED WARRANTIES OF MERCHANTABILITY, FITNESS FOR A PARTICULAR PURPOSE (AND THEIR EQUIVALENTS UNDER THE LAWS OF ANY JURISDICTION), OR INFRINGEMENT OF ANY PATENT, COPYRIGHT OR OTHER INTELLECTUAL PROPERTY RIGHT.

UNLESS EXPRESSLY APPROVED IN WRITING BY AN AUTHORIZED ST REPRESENTATIVE, ST PRODUCTS ARE NOT RECOMMENDED, AUTHORIZED OR WARRANTED FOR USE IN MILITARY, AIR CRAFT, SPACE, LIFE SAVING, OR LIFE SUSTAINING APPLICATIONS, NOR IN PRODUCTS OR SYSTEMS WHERE FAILURE OR MALFUNCTION MAY RESULT IN PERSONAL INJURY, DEATH, OR SEVERE PROPERTY OR ENVIRONMENTAL DAMAGE. ST PRODUCTS WHICH ARE NOT SPECIFIED AS "AUTOMOTIVE GRADE" MAY ONLY BE USED IN AUTOMOTIVE APPLICATIONS AT USER'S OWN RISK.

Resale of ST products with provisions different from the statements and/or technical features set forth in this document shall immediately void any warranty granted by ST for the ST product or service described herein and shall not create or extend in any manner whatsoever, any liability of ST.

ST and the ST logo are trademarks or registered trademarks of ST in various countries.

Information in this document supersedes and replaces all information previously supplied.

The ST logo is a registered trademark of STMicroelectronics. All other names are the property of their respective owners.

© 2010 STMicroelectronics - All rights reserved

STMicroelectronics group of companies

Australia - Belgium - Brazil - Canada - China - Czech Republic - Finland - France - Germany - Hong Kong - India - Israel - Italy - Japan - Malaysia - Malta - Morocco - Philippines - Singapore - Spain - Sweden - Switzerland - United Kingdom - United States of America

www.st.com