

N-channel 800 V, 0.470  $\Omega$  typ., 9 A MDmesh™ K5 Power MOSFETs in a TO-220FP and TO-220FP ultra narrow leads

Datasheet - production data

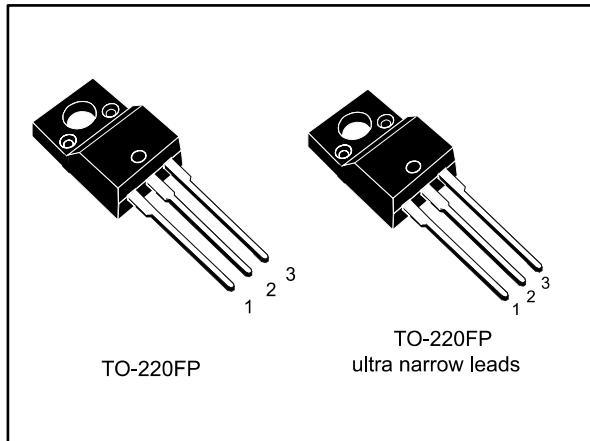
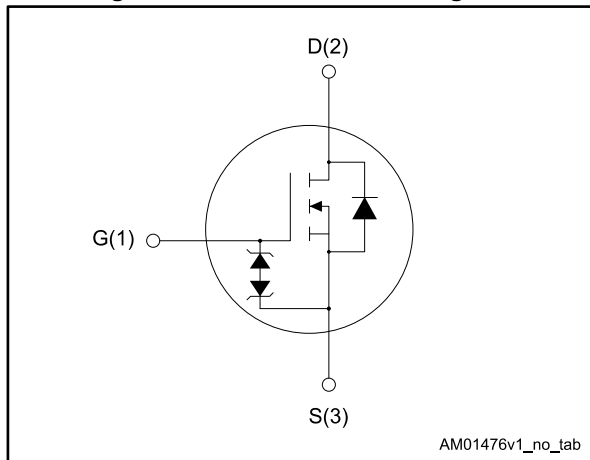

Figure 1: Internal schematic diagram



## Features

Order code	V <sub>DS</sub>	R <sub>DS(on)</sub> max.	I <sub>D</sub>	P <sub>TOT</sub>
STF10N80K5	800 V	0.600 $\Omega$	9 A	30 W
STFU10N80K5				

- Industry's lowest R<sub>DS(on)</sub> x area
- Industry's best figure of merit (FoM)
- Ultra-low gate charge
- 100% avalanche tested
- Zener-protected

## Applications

- Switching applications

## Description

These very high voltage N-channel Power MOSFETs are designed using MDmesh™ K5 technology based on an innovative proprietary vertical structure. The result is a dramatic reduction in on-resistance and ultra-low gate charge for applications requiring superior power density and high efficiency.

Table 1: Device summary

Order code	Marking	Package	Packing
STF10N80K5	10N80K5	TO-220FP	Tube
STFU10N80K5		TO-220FP ultra narrow leads	

---

**Contents**

<b>1</b>	<b>Electrical ratings .....</b>	<b>3</b>
<b>2</b>	<b>Electrical characteristics .....</b>	<b>4</b>
	2.1 Electrical characteristics (curves) .....	6
<b>3</b>	<b>Test circuits .....</b>	<b>9</b>
<b>4</b>	<b>Package information .....</b>	<b>11</b>
	4.1 TO-220FP package information .....	12
	4.2 TO-220FP ultra narrow leads package information .....	14
<b>5</b>	<b>Revision history .....</b>	<b>16</b>

# 1 Electrical ratings

**Table 2: Absolute maximum ratings**

Symbol	Parameter	Value	Unit
$V_{GS}$	Gate-source voltage	$\pm 30$	V
$I_D^{(1)}$	Drain current (continuous) at $T_C = 25\text{ }^\circ\text{C}$	9	A
$I_D^{(1)}$	Drain current (continuous) at $T_C = 100\text{ }^\circ\text{C}$	6	A
$I_{DM}^{(2)}$	Drain current pulsed	36	A
$P_{TOT}$	Total dissipation at $T_C = 25\text{ }^\circ\text{C}$	30	W
$I_{AR}$	Max. current during repetitive or single pulse avalanche (pulse width limited by $T_{Jmax.}$ )	3	A
$E_{AS}$	Single pulse avalanche energy (starting $T_J = 25\text{ }^\circ\text{C}$ , $I_D = I_{AS}$ , $V_{DD} = 50\text{ V}$ )	130	mJ
$V_{ISO}$	Insulation withstand voltage (RMS) from all three leads to external heat sink ( $t = 1\text{ s}$ ; $T_C = 25\text{ }^\circ\text{C}$ )	2500	V
$dv/dt^{(3)}$	Peak diode recovery voltage slope	4.5	V/ns
$dv/dt^{(4)}$	MOSFET $dv/dt$ ruggedness	50	
$T_j$	Operating junction temperature range	- 55 to 150	$^\circ\text{C}$
$T_{stg}$	Storage temperature range		

**Notes:**

(1)Limited by maximum junction temperature.

(2)Pulse width limited by safe operating area.

(3) $I_{SD} \leq 9\text{ A}$ ,  $di/dt \leq 100\text{ A}/\mu\text{s}$ ;  $V_{DS\text{ peak}} \leq V_{(BR)DSS}$

(4) $V_{DS} \leq 640\text{ V}$

**Table 3: Thermal data**

Symbol	Parameter	Value	Unit
$R_{thj-case}$	Thermal resistance junction-case	4.2	$^\circ\text{C}/\text{W}$
$R_{thj-amb}$	Thermal resistance junction-ambient	62.5	$^\circ\text{C}/\text{W}$

## 2 Electrical characteristics

$T_C = 25\text{ °C}$  unless otherwise specified

**Table 4: On/off-state**

Symbol	Parameter	Test conditions	Min.	Typ.	Max.	Unit
$V_{(BR)DSS}$	Drain-source breakdown voltage	$V_{GS} = 0\text{ V}$ , $I_D = 1\text{ mA}$	800			V
$I_{DSS}$	Zero gate voltage drain current	$V_{GS} = 0\text{ V}$ , $V_{DS} = 800\text{ V}$			1	$\mu\text{A}$
		$V_{GS} = 0\text{ V}$ , $V_{DS} = 800\text{ V}$ $T_C = 125\text{ °C}$ <sup>(1)</sup>			50	$\mu\text{A}$
$I_{GSS}$	Gate body leakage current	$V_{DS} = 0\text{ V}$ , $V_{GS} = \pm 20\text{ V}$			$\pm 10$	$\mu\text{A}$
$V_{GS(th)}$	Gate threshold voltage	$V_{DS} = V_{GS}$ , $I_D = 100\text{ }\mu\text{A}$	3	4	5	V
$R_{DS(on)}$	Static drain-source on-resistance	$V_{GS} = 10\text{ V}$ , $I_D = 4.5\text{ A}$		0.470	0.600	$\Omega$

**Notes:**

<sup>(1)</sup>Defined by design, no subject to production test.

**Table 5: Dynamic**

Symbol	Parameter	Test conditions	Min.	Typ.	Max.	Unit
$C_{iss}$	Input capacitance	$V_{DS} = 100\text{ V}$ , $f = 1\text{ MHz}$ , $V_{GS} = 0\text{ V}$	-	635	-	pF
$C_{oss}$	Output capacitance		-	53	-	pF
$C_{rss}$	Reverse transfer capacitance		-	0.8	-	pF
$C_{o(tr)}$ <sup>(1)</sup>	Equivalent capacitance time related	$V_{DS} = 0\text{ to }640\text{ V}$ , $V_{GS} = 0\text{ V}$	-	85	-	pF
$C_{o(er)}$ <sup>(2)</sup>	Equivalent capacitance energy related				34	-
$R_g$	Intrinsic gate resistance	$f = 1\text{ MHz}$ , $I_D = 0\text{ A}$	-	6	-	$\Omega$
$Q_g$	Total gate charge	$V_{DD} = 640\text{ V}$ , $I_D = 9\text{ A}$ $V_{GS} = 10\text{ V}$ See <a href="#">Figure 16: "Test circuit for gate charge behavior"</a>	-	22	-	nC
$Q_{gs}$	Gate-source charge		-	5.5	-	nC
$Q_{gd}$	Gate-drain charge		-	13.2	-	nC

**Notes:**

<sup>(1)</sup>Time related is defined as a constant equivalent capacitance giving the same charging time as  $C_{oss}$  when  $V_{DS}$  increases from 0 to 80%  $V_{DSS}$ .

<sup>(2)</sup>Energy related is defined as a constant equivalent capacitance giving the same stored energy as  $C_{oss}$  when  $V_{DS}$  increases from 0 to 80%  $V_{DSS}$ .

Table 6: Switching times

Symbol	Parameter	Test conditions	Min.	Typ.	Max.	Unit
$t_{d(on)}$	Turn-on delay time	$V_{DD} = 400\text{ V}$ , $I_D = 4.5\text{ A}$ , $R_G = 4.7\ \Omega$ $V_{GS} = 10\text{ V}$ See <a href="#">Figure 15: "Test circuit for resistive load switching times"</a> and <a href="#">Figure 20: "Switching time waveform"</a>	-	14.5	-	ns
$t_r$	Rise time		-	11	-	ns
$t_{d(off)}$	Turn-off delay time		-	35	-	ns
$t_f$	Fall time		-	14	-	ns

Table 7: Source-drain diode

Symbol	Parameter	Test conditions	Min.	Typ.	Max.	Unit
$I_{SD}$	Source-drain current		-		9	A
$I_{SDM}^{(1)}$	Source-drain current (pulsed)		-		36	A
$V_{SD}^{(2)}$	Forward on voltage	$I_{SD} = 9\text{ A}$ , $V_{GS} = 0\text{ V}$	-		1.5	V
$t_{rr}$	Reverse recovery time	$I_{SD} = 9\text{ A}$ , $di/dt = 100\text{ A}/\mu\text{s}$ ,	-	370		ns
$Q_{rr}$	Reverse recovery charge	$V_{DD} = 60\text{ V}$ , see <a href="#">Figure 17: "Test circuit for inductive load switching and diode recovery times"</a> )	-	4.58		$\mu\text{C}$
$I_{RRM}$	Reverse recovery current		-	25		A
$t_{rr}$	Reverse recovery time	$I_{SD} = 9\text{ A}$ , $di/dt = 100\text{ A}/\mu\text{s}$ ,	-	520		ns
$Q_{rr}$	Reverse recovery charge	$V_{DD} = 60\text{ V}$ , $T_J = 150\text{ }^\circ\text{C}$ see <a href="#">Figure 17: "Test circuit for inductive load switching and diode recovery times"</a>	-	5.88		$\mu\text{C}$
$I_{RRM}$	Reverse recovery current		-	22.5		A

**Notes:**

(1)Pulse width limited by safe operating area.

(2)Pulsed: pulse duration = 300  $\mu\text{s}$ , duty cycle 1.5%.

Table 8: Gate-source Zener diode

Symbol	Parameter	Test conditions	Min	Typ.	Max	Unit
$V_{(BR)GSO}$	Gate-source breakdown voltage	$I_{GS} = \pm 1\text{ mA}$ , $I_D = 0\text{ A}$	30	-	-	V

The built-in back-to-back Zener diodes are specifically designed to enhance the ESD performance of the device. The Zener voltage facilitates efficient and cost-effective device integrity protection, thus eliminating the need for additional external componentry.

## 2.1 Electrical characteristics (curves)

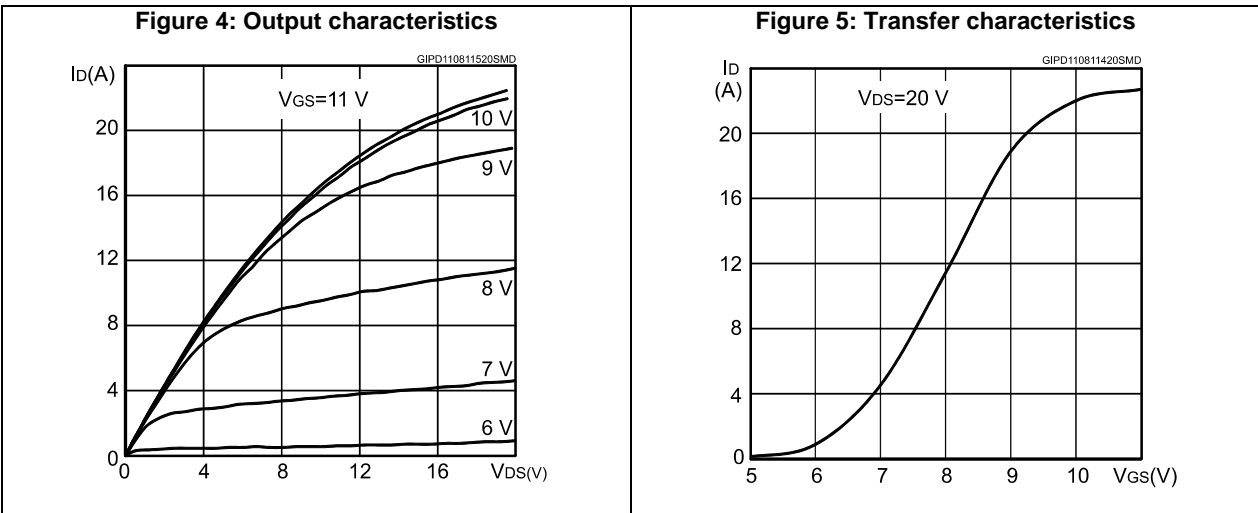
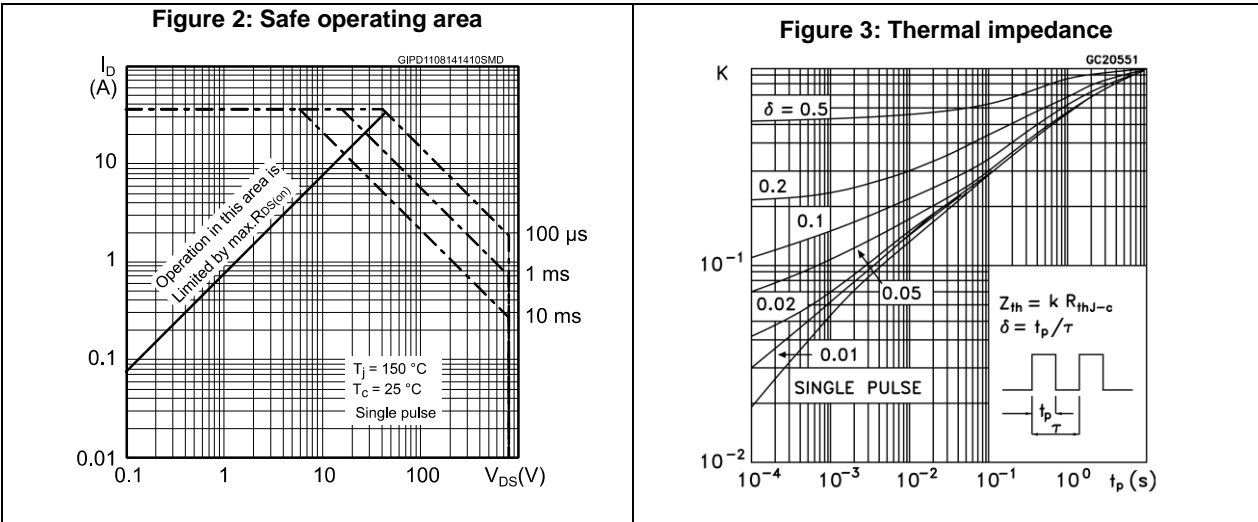

Figure 6: Gate charge vs. gate-source voltage

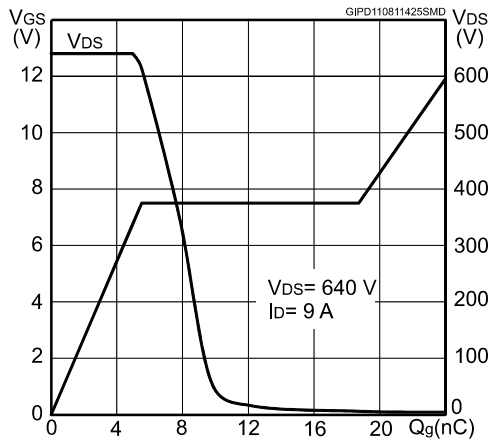

Figure 7: Static drain-source on-resistance

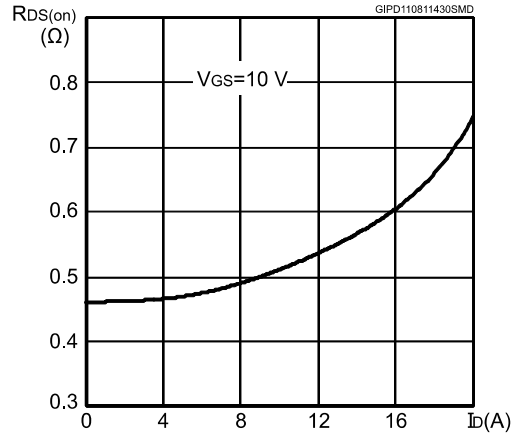

Figure 8: Capacitance variations

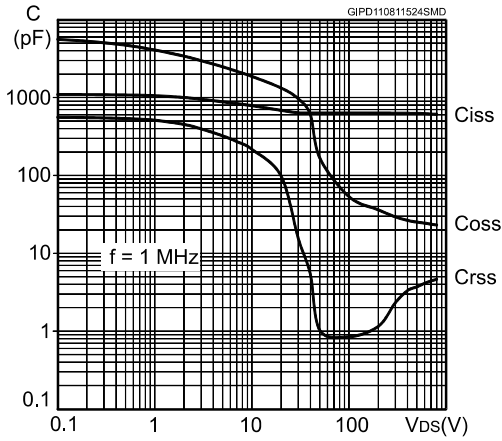

Figure 9: Source-drain diode forward characteristics

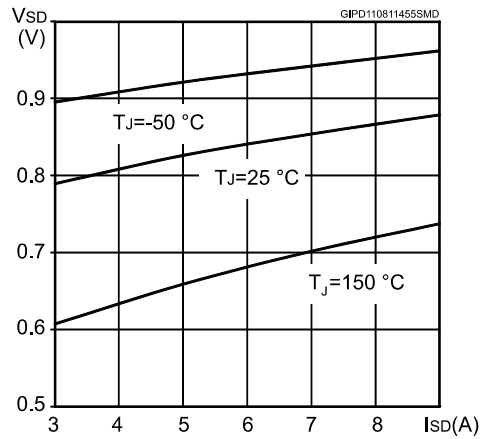

Figure 10: Normalized gate threshold voltage vs. temperature

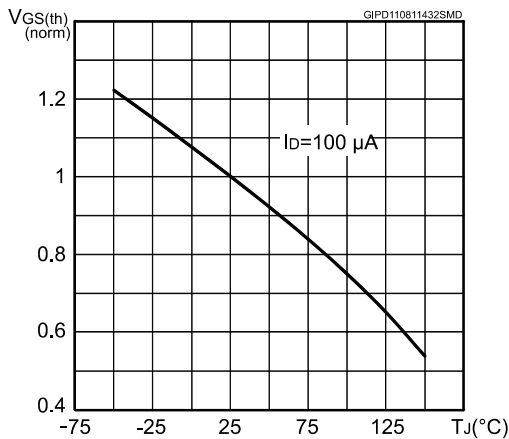

Figure 11: Normalized on-resistance vs. temperature

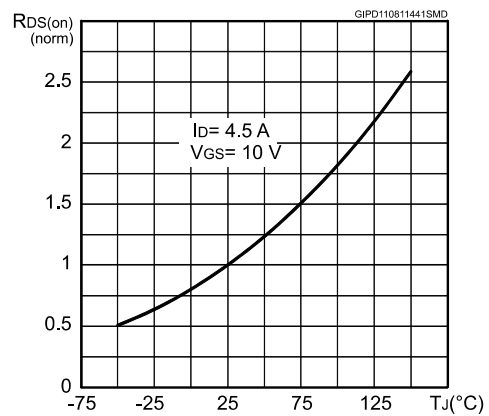

Figure 12: Normalized  $V_{(BR)DSS}$  vs. temperature

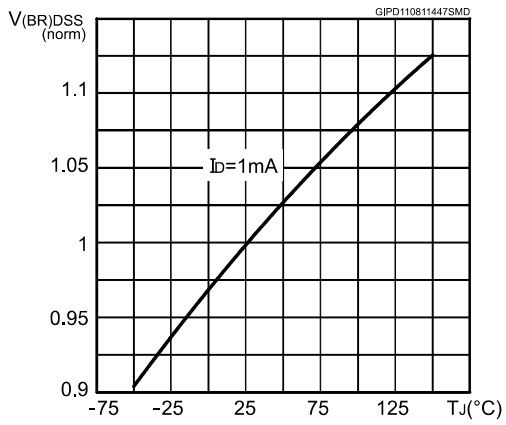

Figure 13: Maximum avalanche energy vs. starting  $T_J$

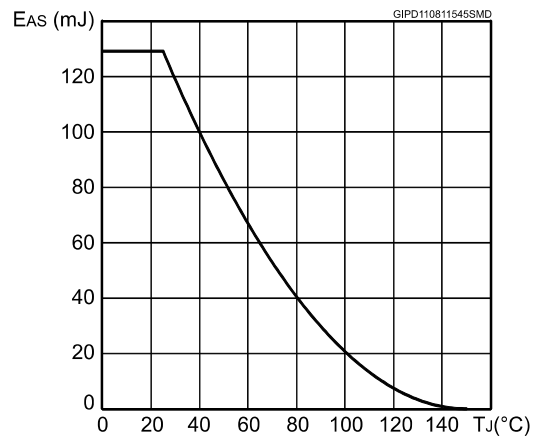
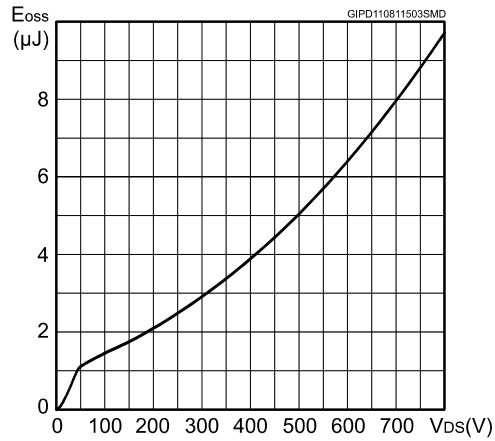

Figure 14: Output capacitance stored energy





### 3 Test circuits

**Figure 15: Test circuit for resistive load switching times**



AM01468v1

**Figure 16: Test circuit for gate charge behavior**

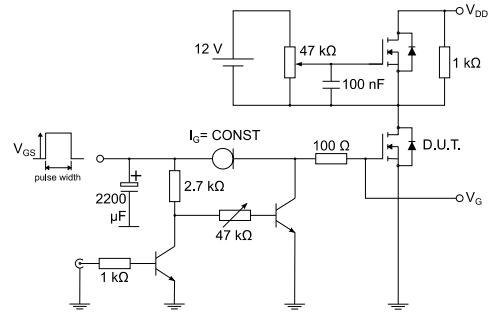

AM01469v1

**Figure 17: Test circuit for inductive load switching and diode recovery times**

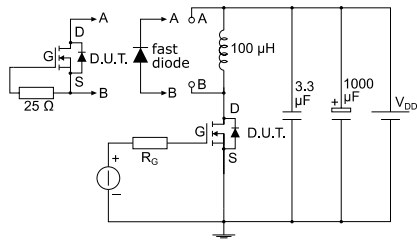

AM01470v1

**Figure 18: Unclamped inductive load test circuit**

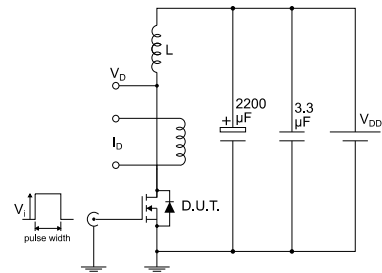

AM01471v1

Figure 19: Unclamped inductive waveform

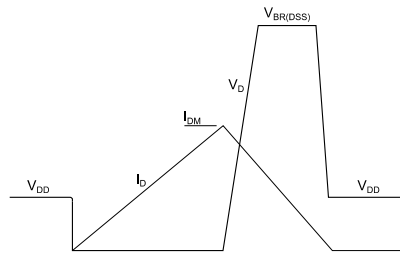

AM01472v1

Figure 20: Switching time waveform

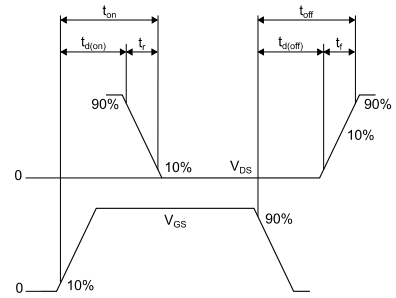

AM01473v1

## 4 Package information

In order to meet environmental requirements, ST offers these devices in different grades of ECOPACK® packages, depending on their level of environmental compliance. ECOPACK® specifications, grade definitions and product status are available at: [www.st.com](http://www.st.com). ECOPACK® is an ST trademark.

### 4.1 TO-220FP package information

Figure 21: TO-220FP package outline

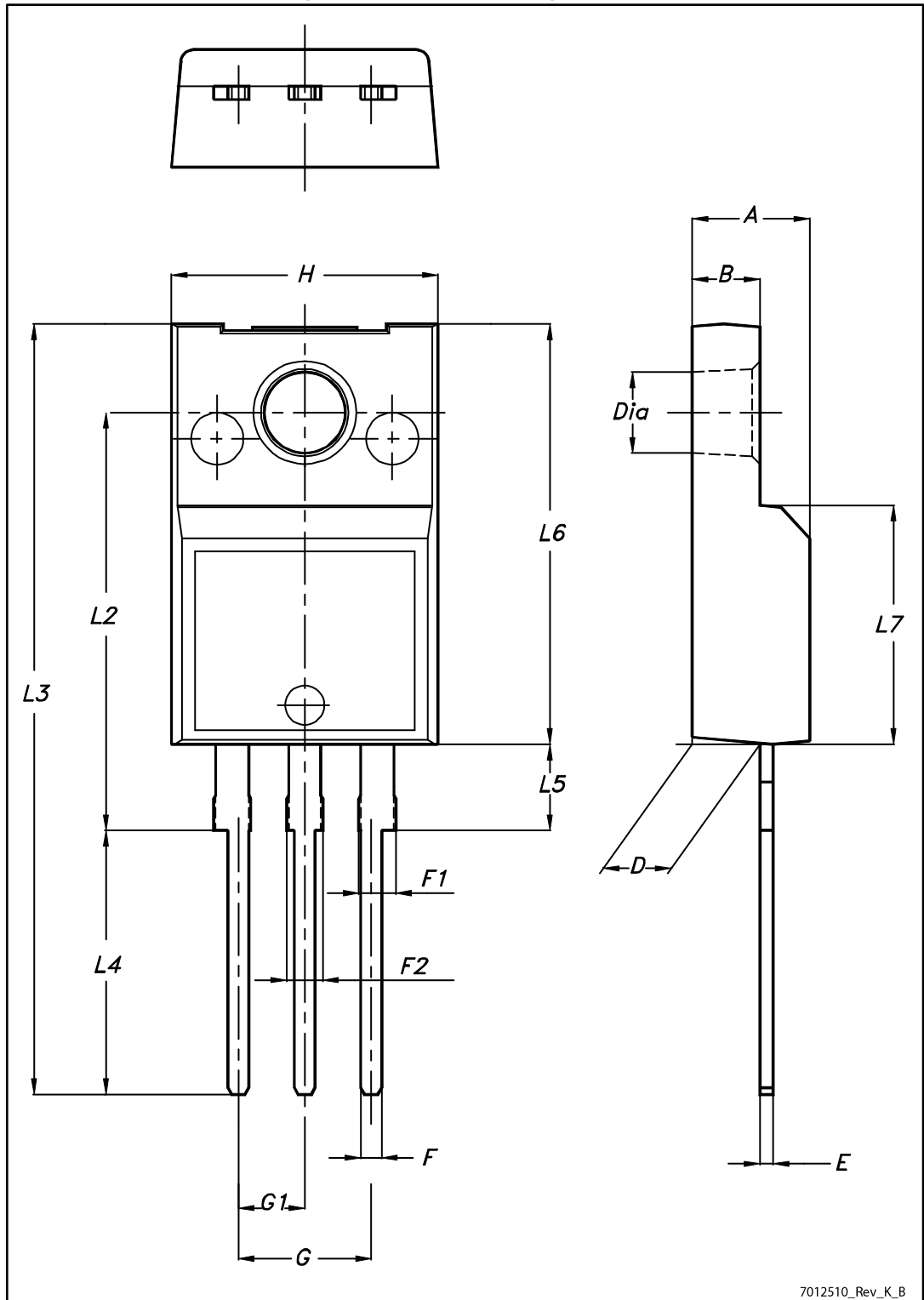

7012510\_Rev\_K\_B

Table 9: TO-220FP package mechanical data

Dim.	mm		
	Min.	Typ.	Max.
A	4.4		4.6
B	2.5		2.7
D	2.5		2.75
E	0.45		0.7
F	0.75		1
F1	1.15		1.70
F2	1.15		1.70
G	4.95		5.2
G1	2.4		2.7
H	10		10.4
L2		16	
L3	28.6		30.6
L4	9.8		10.6
L5	2.9		3.6
L6	15.9		16.4
L7	9		9.3
Dia	3		3.2

### 4.2 TO-220FP ultra narrow leads package information

Figure 22: TO-220FP ultra narrow leads package outline

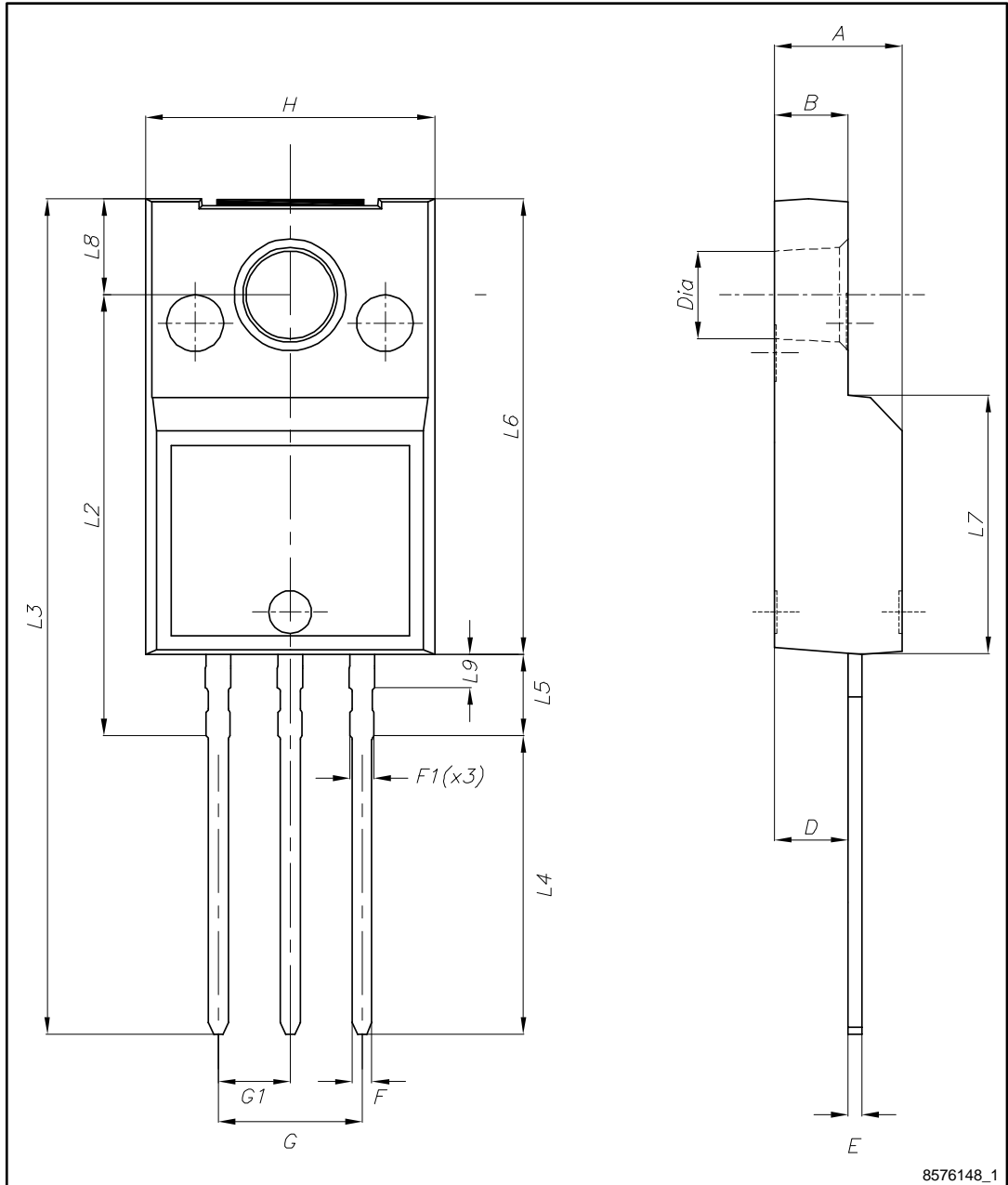

8576148\_1

Table 10: TO-220FP ultra narrow leads mechanical data

Dim.	mm		
	Min.	Typ.	Max.
A	4.40		4.60
B	2.50		2.70
D	2.50		2.75
E	0.45		0.60
F	0.65		0.75
F1	-		0.90
G	4.95		5.20
G1	2.40	2.54	2.70
H	10.00		10.40
L2	15.10		15.90
L3	28.50		30.50
L4	10.20		11.00
L5	2.50		3.10
L6	15.60		16.40
L7	9.00		9.30
L8	3.20		3.60
L9	-		1.30
Dia.	3.00		3.20

## 5 Revision history

Table 11: Document revision history

Date	Revision	Changes
23-Jun-2014	1	First release.
13-Aug-2014	2	-Document status promoted from preliminary to production data. -Inserted <i>Section 3: Electrical characteristics (curves)</i> . -Minor text changes.
17-Sep-2014	3	Updated title, features and description in cover page.
05-Nov-2014	4	Updated <i>Section 3: Electrical characteristics (curves)</i> . Minor text changes.
08-Sep-2016	5	Added the order code STF10N80K5 and the relative <a href="#">Section 4.2: "TO-220FP ultra narrow leads package information"</a> .



**IMPORTANT NOTICE – PLEASE READ CAREFULLY**

STMicroelectronics NV and its subsidiaries ("ST") reserve the right to make changes, corrections, enhancements, modifications, and improvements to ST products and/or to this document at any time without notice. Purchasers should obtain the latest relevant information on ST products before placing orders. ST products are sold pursuant to ST's terms and conditions of sale in place at the time of order acknowledgement.

Purchasers are solely responsible for the choice, selection, and use of ST products and ST assumes no liability for application assistance or the design of Purchasers' products.

No license, express or implied, to any intellectual property right is granted by ST herein.

Resale of ST products with provisions different from the information set forth herein shall void any warranty granted by ST for such product.

ST and the ST logo are trademarks of ST. All other product or service names are the property of their respective owners.

Information in this document supersedes and replaces information previously supplied in any prior versions of this document.

© 2016 STMicroelectronics – All rights reserved