

Low-cost SDTV set-top box decoder for H.264/AVC and MPEG-2

Data Brief

Features

- The STi5200 is a single-chip, standard-definition STB decoder including:
 - ST40 CPU core, 266 MHz
 - dual ST231 CPU cores for audio and video decoding, both 400 MHz
 - transport filtering and descrambling
 - video decoder: H.264/AVC and MPEG-2
- graphics engine and dual display: enhanced definition ED (480p/576p) and standard definition SD (480i/576i)
- audio decoder
- The STi5200 also features the following embedded interfaces:
 - USB 2.0
 - digital audio and video auxiliary input
 - modem

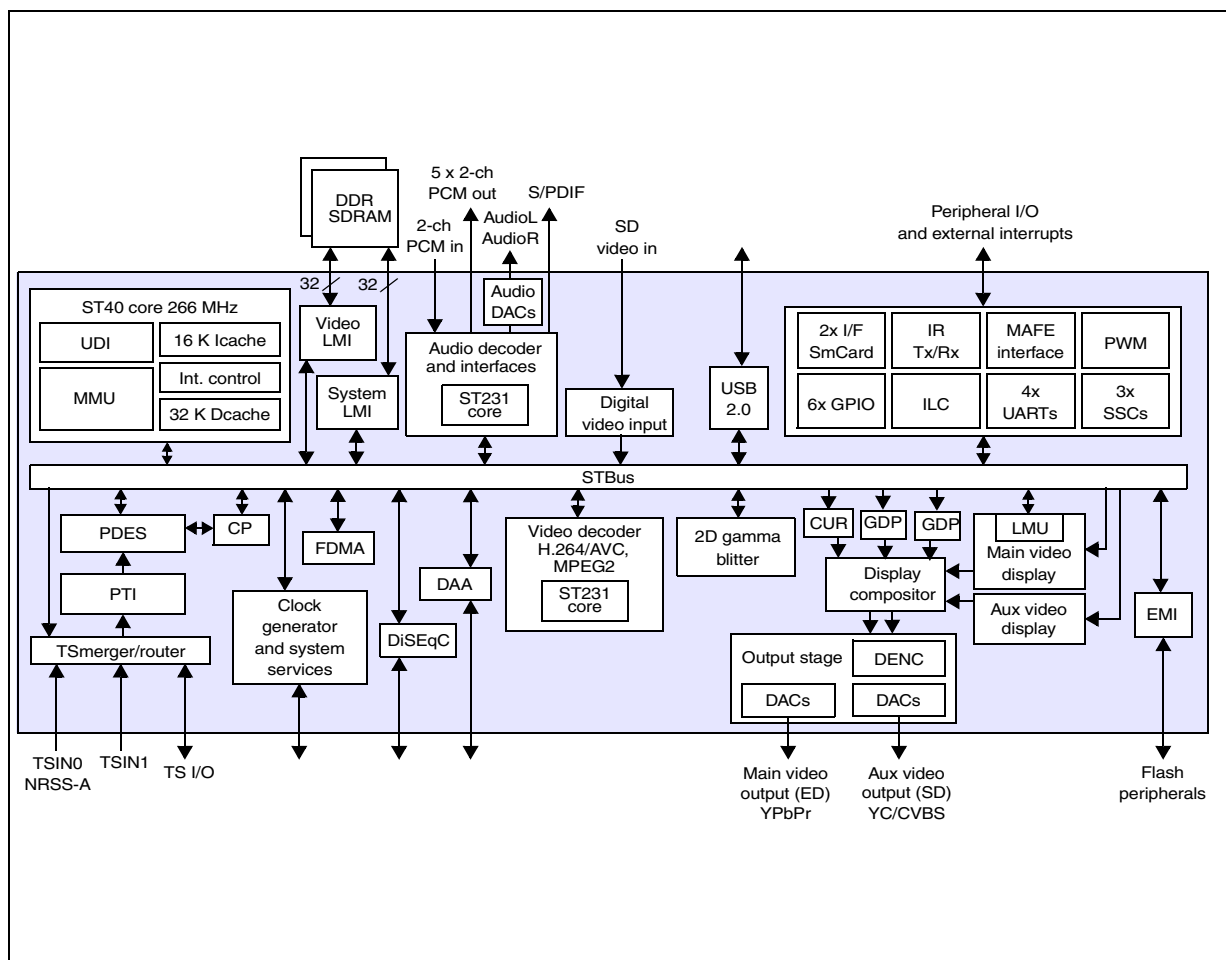

1 Description

www.datasheet4u.com

The STi5200 is a new generation, standard-definition set-top box decoder chip, which provides very high performance for low-cost systems. With enhanced performance over the STi7710, it includes an H.264/AVC decoder for new low-bitrate applications, and dual-decode MPEG-2 capability.

Based on the Omega2 (STBus) architecture, this system on chip is a full back-end processing solution for digital terrestrial, satellite and cable standard-definition set-top boxes compliant with ATSC, DVB, DIRECTV, DCII, OpenCable and ARIB BS4 specifications.

The STi5200 demultiplexes, decrypts and decodes SD video streams with associated multichannel audio. Video is output to two independently formatted displays: a full resolution display intended for a TV monitor, and a downsampled display intended for a VCR. Connection to a TV or display panel is through an analog component interface. Composite outputs are provided for connection to the VCR with Macrovision protection. Audio is output with optional PCM mixing to an S/PDIF interface, PCM interface or through integrated stereo audio DACs.

Digitized analog programs can also be input to the STi5200 for reformatting and display.

The STi5200 can render and display graphics, and has a 2D graphics accelerator, two graphics planes and a cursor plane. A dual display compositor provides mixing of graphics and video with independent composition for each of the TV and VCR outputs.

The STi5200 includes a stream merger to allow five different transport streams from different sources to be merged and processed concurrently. Applications include DVR time shifted viewing of a terrestrial program while acquiring an EPG/data stream from a satellite or cable front end.

The flexible descrambling engine is compatible with required standards including DVB, DES, AES and Multi2.

2 Applications

www.datasheet4u.com

The STi5200 has an embedded 266 MHz ST40 CPU for applications and device control. DDR1 SDRAM memory is used for higher performance, to allow the video decoder the required memory bandwidth for H.264 decoding and sufficient bandwidth for the CPU and the rest of the system. A second memory bus is provided for flash memory storing resident software and for connecting peripherals.

A hard-disk drive (HDD) can be connected as an expansion drive using the USB 2.0 port. The USB port can also be used to connect to a DOCSIS 2.0 CM gateway for interactive cable applications.

The STi5200 is supported by STMicroelectronics' STAPI software.

Figure 1. Low-cost satellite SD set-top box

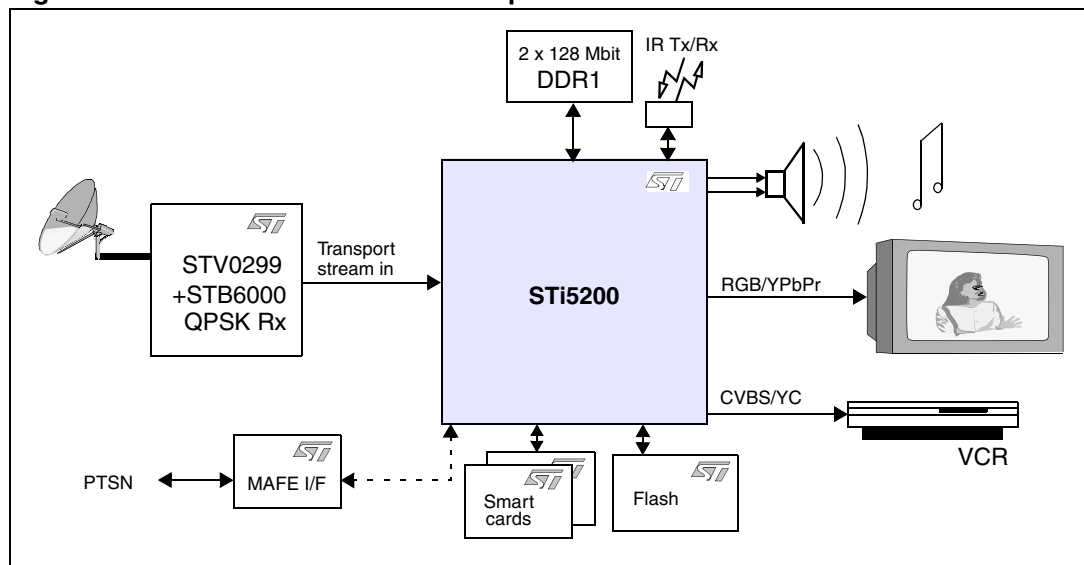
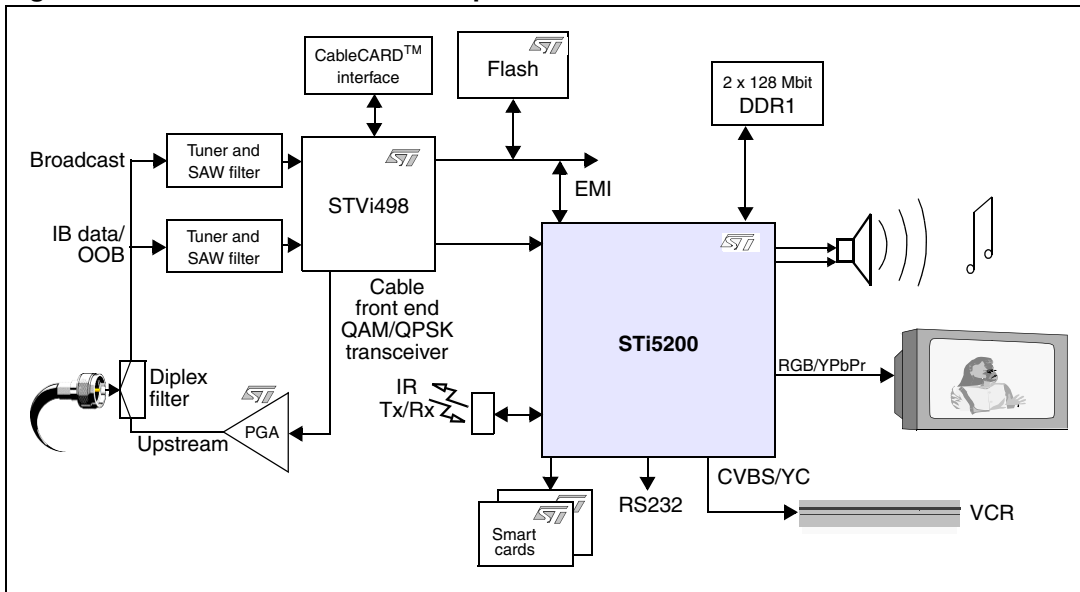

Figure 2. Low-cost cable SD set-top box with return channel



www.datasheet4u.com

Figure 3. Low-cost dual satellite and terrestrial SD set-top box with HDD

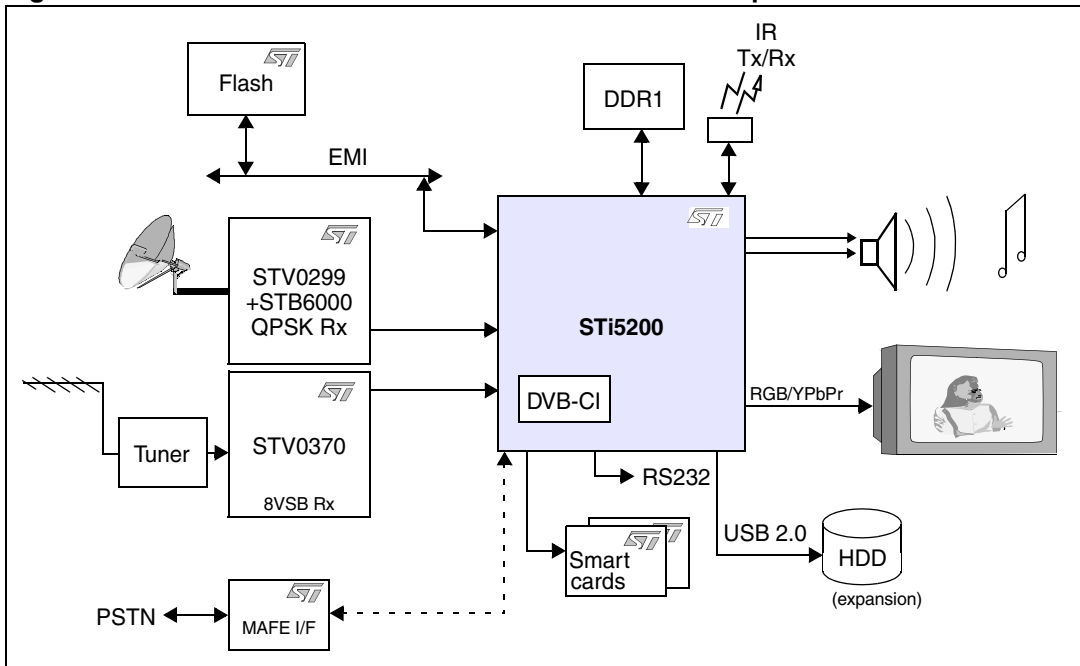
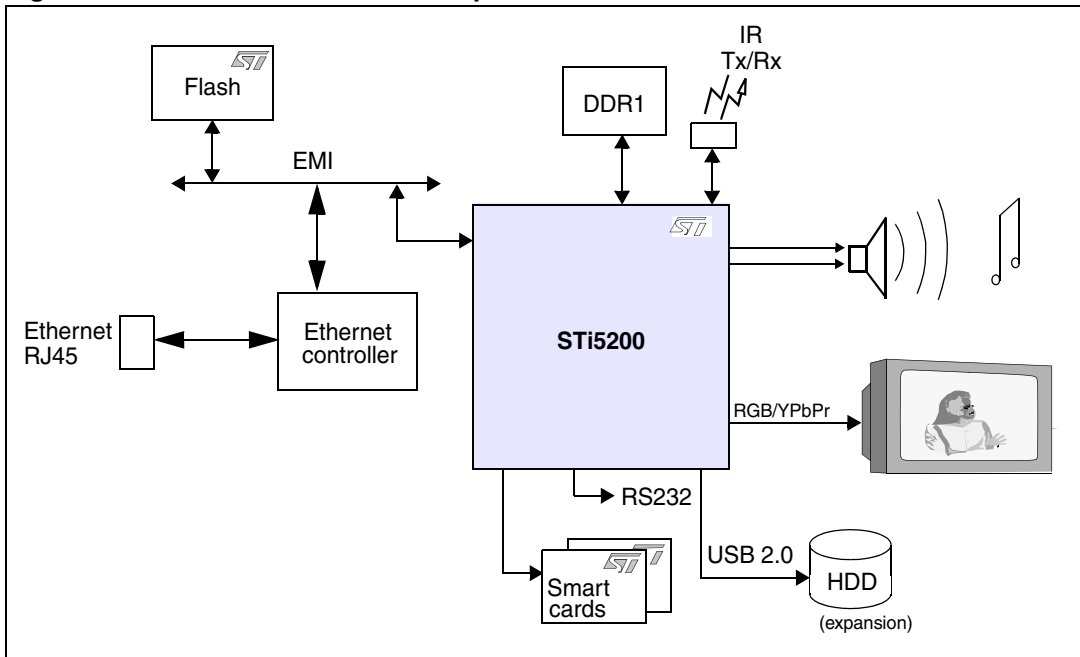

Figure 4. Low-cost SD IP-TV set-top box with HDD



www.datasheet4u.com

3 Revision history

www.datasheet4u.com

Table 1. Document revision history

| Date | Revision | Changes |
|-------------|----------|------------------|
| 16-Feb-2007 | 1 | Initial release. |

Please Read Carefully:

Information in this document is provided solely in connection with ST products. STMicroelectronics NV and its subsidiaries ("ST") reserve the right to make changes, corrections, modifications or improvements, to this document, and the products and services described herein at any time, without notice.

All ST products are sold pursuant to ST's terms and conditions of sale.

Purchasers are solely responsible for the choice, selection and use of the ST products and services described herein, and ST assumes no liability whatsoever relating to the choice, selection or use of the ST products and services described herein.

No license, express or implied, by estoppel or otherwise, to any intellectual property rights is granted under this document. If any part of this document refers to any third party products or services it shall not be deemed a license grant by ST for the use of such third party products or services, or any intellectual property contained therein or considered as a warranty covering the use in any manner whatsoever of such third party products or services or any intellectual property contained therein.

UNLESS OTHERWISE SET FORTH IN ST'S TERMS AND CONDITIONS OF SALE ST DISCLAIMS ANY EXPRESS OR IMPLIED WARRANTY WITH RESPECT TO THE USE AND/OR SALE OF ST PRODUCTS INCLUDING WITHOUT LIMITATION IMPLIED WARRANTIES OF MERCHANTABILITY, FITNESS FOR A PARTICULAR PURPOSE (AND THEIR EQUIVALENTS UNDER THE LAWS OF ANY JURISDICTION), OR INFRINGEMENT OF ANY PATENT, COPYRIGHT OR OTHER INTELLECTUAL PROPERTY RIGHT.

UNLESS EXPRESSLY APPROVED IN WRITING BY AN AUTHORIZED ST REPRESENTATIVE, ST PRODUCTS ARE NOT RECOMMENDED, AUTHORIZED OR WARRANTED FOR USE IN MILITARY, AIR CRAFT, SPACE, LIFE SAVING, OR LIFE SUSTAINING APPLICATIONS, NOR IN PRODUCTS OR SYSTEMS WHERE FAILURE OR MALFUNCTION MAY RESULT IN PERSONAL INJURY, DEATH, OR SEVERE PROPERTY OR ENVIRONMENTAL DAMAGE. ST PRODUCTS WHICH ARE NOT SPECIFIED AS "AUTOMOTIVE GRADE" MAY ONLY BE USED IN AUTOMOTIVE APPLICATIONS AT USER'S OWN RISK.

Resale of ST products with provisions different from the statements and/or technical features set forth in this document shall immediately void any warranty granted by ST for the ST product or service described herein and shall not create or extend in any manner whatsoever, any liability of ST.

ST and the ST logo are trademarks or registered trademarks of ST in various countries.

Information in this document supersedes and replaces all information previously supplied.

The ST logo is a registered trademark of STMicroelectronics. All other names are the property of their respective owners.

© 2007 STMicroelectronics - All rights reserved

STMicroelectronics group of companies

Australia - Belgium - Brazil - Canada - China - Czech Republic - Finland - France - Germany - Hong Kong - India - Israel - Italy - Japan - Malaysia - Malta - Morocco - Singapore - Spain - Sweden - Switzerland - United Kingdom - United States of America

www.st.com

