

STIR4210/STIR4220

USB 2.0 Hi-Speed to IrDA Bridge

FEATURES

■ **Complete System Solution for Implementing IR Communications on USB**

- ◆ USB 2.0 High Speed Device Controller Interface
- ◆ Complete IrDA Protocol Engine
- ◆ High Integration Minimizes External Components

■ **USB 2.0 Device Controller**

- ◆ Compatible with USB 2.0 Specification for High Speed Operation
- ◆ Integrated USB 2.0 Transceivers
- ◆ Control, Bulk In, Bulk Out endpoints
- ◆ Compatible with Bus Powered Specification
- ◆ Configurable Vendor ID and Subsystem ID

■ **High Performance IrDA Protocol Controller**

- ◆ Compatible with IrDA Serial Infrared Physical Layer Specification 1.4
- ◆ Supports SIR, MIR, FIR, and VFIR rates up to 16 Mbits/second (STIR4220)
- ◆ Supports SIR, MIR, and FIR rates up to 4 Mbits/sec (STIR4210)
- ◆ Supports communication of unframed raw data for remote control and proprietary applications

■ **Embedded High Performance Microcontroller Provides Control Functions**

- ◆ Internal Program ROM
- ◆ Internal RAM for Data, Buffering, Scratchpad, and Program ROM Patch

■ **Transceiver Identification for automatic driver configuration**

■ **Integrated PLL**

■ **Integrated 5.0V-3.3V and 3.3V-1.8V Linear Voltage Regulators Provide Power for Typical Configurations**

■ **1.8V Low Power Core Operation.**

■ **3.3V I/O with 5.0V Input Tolerance**

■ **32-pad QFN Leadless Package (5mm x 5mm) minimizes board space requirements**

■ **Supports MAC OS, Linux, WinME, Win2000, Win XP and later Windows OSs**

DESCRIPTION

The SigmaTel STIR4210 and STIR4220 are low power, USB 2.0 Hi-Speed IrDA Bridge Controller integrated circuits for enabling USB IrDA communication solutions. The STIR4210/STIR4220 connect directly to the USB Bus and provide all functionality necessary between the USB 2.0 and an IR transceiver. A USB IR communication subsystem can be implemented by adding an IR transceiver, a 24 MHz crystal, and a few passive components for bypass and power filtering.

The STIR4210/STIR4220 are compatible with the IrDA Serial Infrared Physical Layer Specification Version 1.4. The STIR4210 supports data rates up to 4 Mbits per second (FIR) and the STIR4220 supports data rates up to 16 Mbits per second (VFIR) including FIR. Both devices support all of the lower data rates defined by the IrDA specification (SIR and MIR).

The STIR4210/STIR4220 implement a USB 2.0 Hi-Speed device controller including integrated PHY/transceivers, an IR Protocol Controller, a programmable microcontroller, memory for program and buffering, and voltage regulators required for the typical USB based Infrared subsystem.

A high performance microcontroller provides control functions. On-chip program ROM and program/data RAM eliminates the need for external components. RAM is used for data, buffering, and ROM patch.

The IR Protocol Controller supports the IrDA encode and decode operations required by the various data rates and allows the STIR4210/STIR4220 to interface to a wide range of IR capable devices at the highest performance. Unframed transfers are supported for proprietary and remote control applications.

GPIO pins support the control of external functions. These pins include an activity LED and pins for transceiver ID. These pins can be used so that the driver can detect which transceiver is used and configure performance parameters if necessary. An integrated PLL generates all on-chip clocks from a 24 MHz crystal. Integrated voltage regulators convert the USB 5.0V power to 1.8V and 3.3V power required by the device and the IrDA transceiver.

Preliminary - 11/10/03

2-4210/20-P1-0.92-1103

STIR4210/STIR4220

USB 2.0 Hi-Speed to IrDA Bridge



BLOCK DIAGRAM

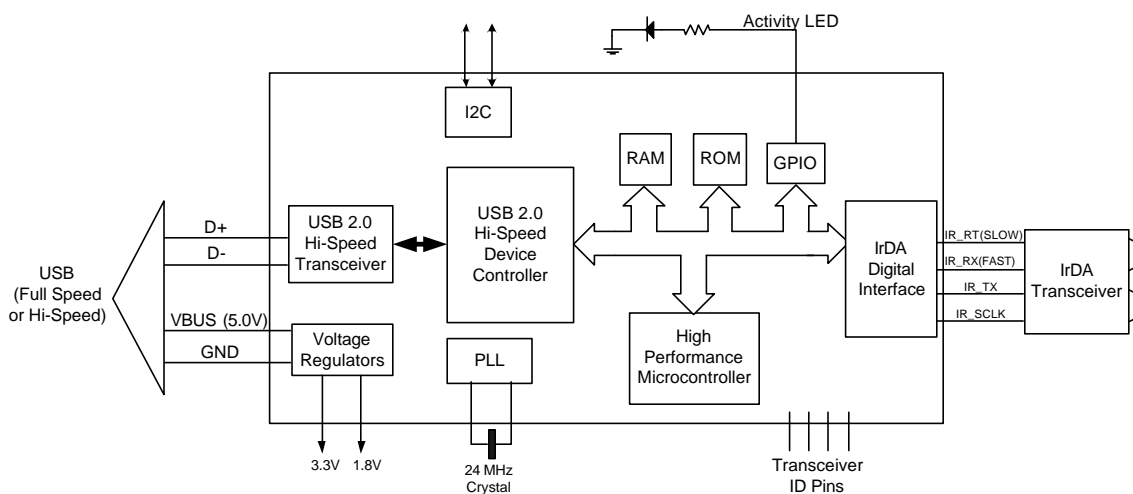

PIN DIAGRAM

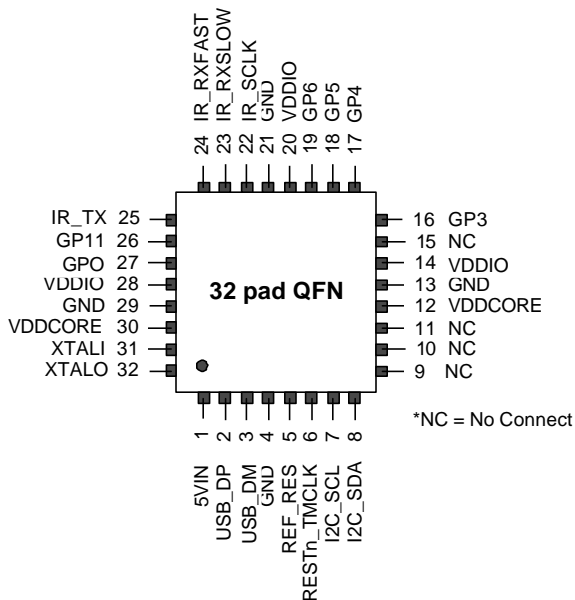

PACKAGE TYPE

	TOP	Dimensions
	BOTTOM	5 x 5 x 0.9 mm

SOFTWARE DETAILS

- Drivers support Windows98 SE, Win2000, WinXP, MAC OS 9.0 and later, and Linux version 2.4.0 and later

ADDITIONAL PRODUCT SUPPORT

- Data Sheet
- Manufacturable reference design
- Manufacturer utilities

ORDERING INFORMATION

Part Number	Package	Temp Range	Supply Range
STIR4210N	32-Pad QFN	0° C to +70° C	Vdd = 3.1 - 3.6V
STIR4220N	32-Pad QFN	0° C to +70° C	Vdd = 3.1 - 3.6V

Copyright © 2003 SigmaTel, Inc. All rights reserved.

All contents of this document are protected by copyright law and may not be reproduced without the express written consent of SigmaTel, Inc.

SigmaTel, the SigmaTel logo, and combinations thereof are trademarks of SigmaTel, Inc. Other product names used in this publication are for identification purposes only and may be trademarks or registered trademarks of their respective companies. The contents of this document are provided in connection with SigmaTel, Inc. products. SigmaTel, Inc. has made best efforts to ensure that the information contained herein is accurate and reliable. However, SigmaTel, Inc. makes no warranties, express or implied, as to the accuracy or completeness of the contents of this publication and is providing this publication "AS IS". SigmaTel, Inc. reserves the right to make changes to specifications and product descriptions at any time without notice, and to discontinue or make changes to its products at any time without notice. SigmaTel, Inc. does not assume any liability arising out of the application or use of any product or circuit, and specifically disclaims any and all liability, including without limitation special, consequential, or incidental damages.