



# STK32562

**Ambient Light Sensor and Proximity Sensor with I2C interface**

---

**Datasheet**

Version – 0.9.0

Hazardous Substance Free  
RoHS / REACH Compliant

**Sensortek Technology Corporation**

## 1. OVERVIEW

### Description

The STK32562 is an integrated ambient and infrared light to digital converter with I<sup>2</sup>C interface. This device provides not only ambient light sensing to allow robust backlight/display brightness control but also infrared sensing to allow proximity estimation featured with interrupt function.

For ambient light sensing, the STK32562 incorporates a photodiode, timing controller and ADC in a single chip. The excellent spectral response is designed to be close-to human eye. The STK32562 is suitable for detecting a wide range of light intensity environment.

For proximity sensing, the STK32562 also incorporates a photodiode, timing controller and ADC in the same chip. The spectral response of STK32562 is optimized for wavelength 940nm infrared light. The STK32562 provides programmable current setting to drive IR LED and employs a noise cancellation scheme to highly reject unwanted ambient IR noise.

The STK32562 has excellent temperature compensation, robust on-chip refresh rate setting without external components. Software shutdown mode control is provided for power saving application. The STK32562 operating voltage range is 1.7V to 2.0V.

### Feature

- Integrated ambient light sensor, proximity sensor and infrared LED in one package.

#### Proximity Sensor

- 16 bits resolution for proximity detection
- Built-in LED driver with flexible setting
  - LED turn-on time : 7 steps IT
  - LED current : 3.125 / 6.25 / 12.5 / 25 / 50 / 75 / 100 / 125 / 150 / 175 / 200 mA
- Flexible interrupt setting
  - Several interrupt modes meet application requirements
  - Flag modes are included
  - Persistence : 1/2/4/8 times
- Low noise design
- High ambient light suppression

#### Ambient Light Sensor

- Convert ambient light intensity to 16-bit digital data format
- 3rd generation ambient light sensor which closes to human-eye response and suppress IR portion
- Flexible digital settings
  - Integration time : 7 steps IT
- Flexible interrupt setting
  - Interrupt while out-of- window
  - Persistence : 1/2/4/8 times
- Clear channel for different light source compensation

#### General

- Fully digital control with I<sup>2</sup>C interface
  - 1.7 ~ 3.6V I<sup>2</sup>C interface
- Low power design
  - Standby mode
  - Wait mode
- V<sub>DD</sub> wide operation voltage : 1.7~2.0V
- Excellent temperature compensation: -40 to 85°C
- Available package options: OLGA
  - STK32562 : 2.15 x 1.4 x 0.6 (mm)
- Lead-free package (RoHS compliant)
- Moisture Sensitivity Level 3

### Applications

- Mobile Phone, Smart-phone, PDA

**2. FUNCTION BLOCK**

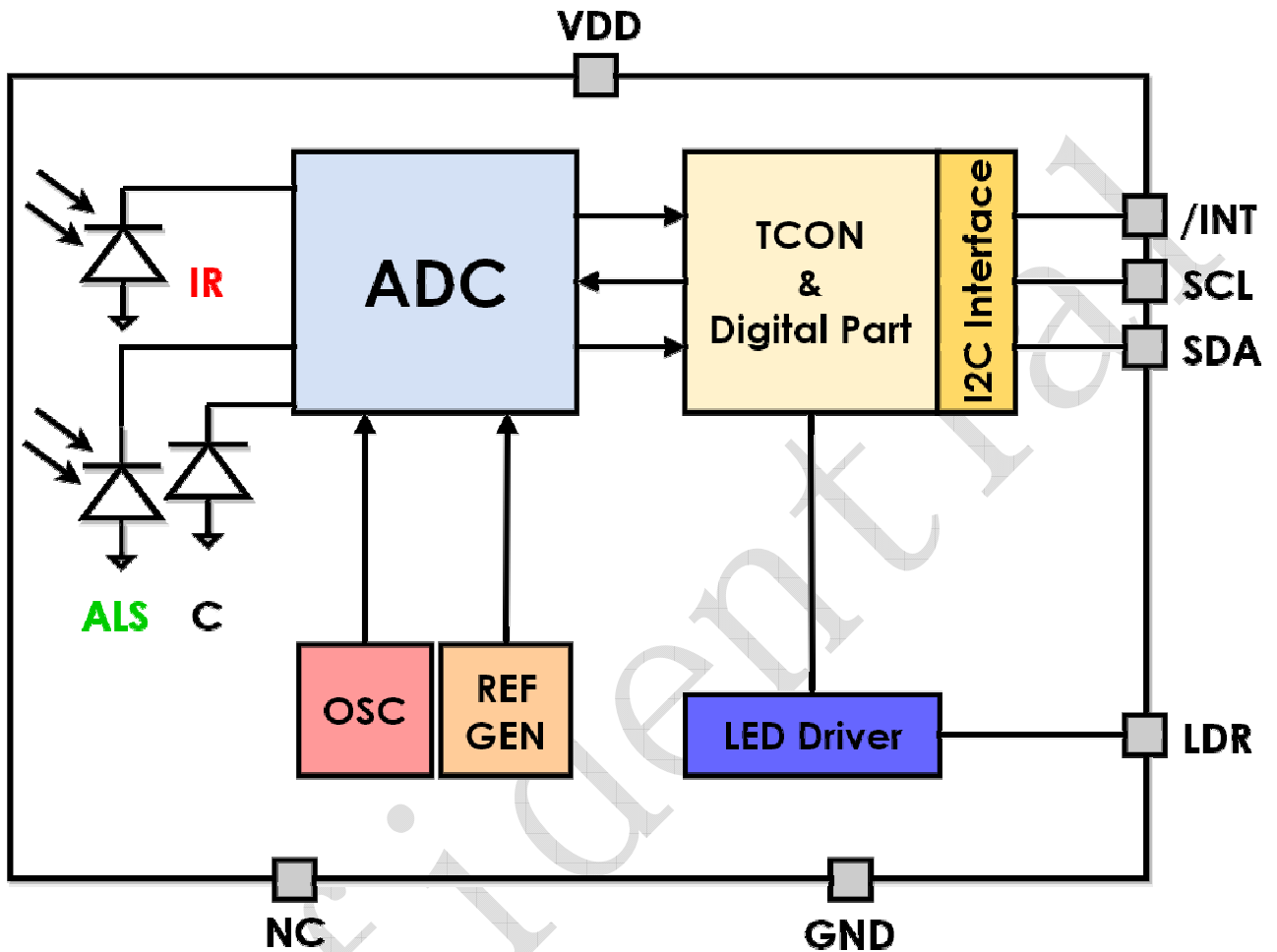

### 3. PINOUT DIAGRAM

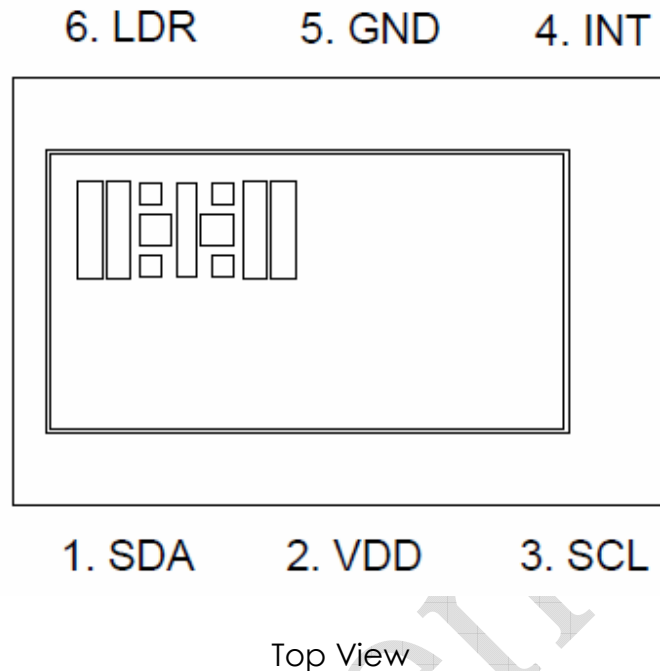

### 4. PIN DESCRIPTION

Pin No.	Pin Name	Dir.	Pin Function
1	SDA	B	I <sup>2</sup> C serial data line. (Open Drain)
2	VDD	PWR	Power supply: 1.7V to 2.0V.
3	SCL	I	I <sup>2</sup> C serial clock line.
4	/INT	O	Interrupt pin, LO for interrupt alarming. (Open Drain)
5	GND	GND	Ground. The thermal pad is also connected to the GND pin.
6	LDR	I	IR LED driver pin connecting to the cathode of the external IR LED. The sink current of the IR LED driver can be programmed through I <sup>2</sup> C or the external resistor.

Direction denotation:

O	Output	GND	Ground
I	Input	B	Bi-direction
PWR	Power	NC	Not Connect

## 5. ELECTRICAL SPECIFICATIONS

### Absolute Maximum Ratings

Symbol	Parameter	Min.	Max.	Unit
V <sub>DD</sub>	Supply voltage	-0.3	2.0	V
V <sub>LEDA</sub>	Voltage of LED's anode	-0.3	4.7	V
V <sub>LDR</sub>	Voltage of LDR		3.6	V
T <sub>a</sub>	Operation temperature	-40	85	°C

NOTE: All voltages are measured with respect to GND

### Recommended Operating Conditions

Symbol	Parameter	Min.	Max.	Unit
V <sub>DD</sub>	Supply voltage	1.7	2.0	V
V <sub>LEDA</sub>	Voltage of LED's anode	2.8	4.6	V
f <sub>I2C</sub>	Clock frequency of I <sup>2</sup> C	—	400	KHz
T <sub>a</sub>	Operation temperature	-40	85	°C

NOTE: All voltages are measured with respect to GND

Symbol	Parameter	Max.	Unit
ESD	Electrostatic discharge protection	2 (HBM)	kV
		200 (MM)	V
		100 (Latch Up)	mA

NOTE: All voltages are measured with respect to GND

## 5.1 Electrical and Optical Characteristics

$V_{DD} = 1.8V$  &  $V_{LED} = 2.8V$ , under room temperature  $25^{\circ}C$  (unless otherwise noted)

Symbol	Parameter	Condition	Min.	Typ.	Max.	Unit
Operation Characteristics						
$I_{ALS}$	ALS only supply current	Note1,2		TBD		$\mu A$
$I_{PS}$	PS only supply current	Note1,2		TBD		$\mu A$
$I_{SD}$	Shutdown current	Note1,2		TBD		$\mu A$
$V_{IH}$	Logic high, I <sup>2</sup> C	Note6	1.3		$V_{DD}$	V
$V_{IL}$	Logic low, I <sup>2</sup> C	Note7	—		0.4	V
ALS Characteristics						
$\lambda_{p1}$	Peak sensitivity wavelength for ALS			550		nm
$ALS_{FSCNT}$	Full scale ALS counts				65535	counts
$ALS_{DARK}$	ALS dark offset	Note2,3,4		0	4	counts
$ALS_{SENSE}$	ALS sensing tolerance	Note2,3	-12.5		+12.5	%
Proximity Characteristics						
$\lambda_{p2}$	High sensitivity wavelength range for PS		800	940	1000	nm
$PS_{FSCNT}$	Full scale PS counts				65535	counts
$I_{LED_{SINK}}$	LED sink current	IRDR_LED[3:0] Note5				
		0000		3.125		mA
		0001		6.25		mA
		0010		12.5		mA
		0011		25		mA
		0100		50		mA
		0101		75		mA
		0110		100		mA
		0111		125		mA
		1000		150		mA
		1001		175		mA
		1010		200		mA
$AMB_{SUPP}$	Ambient Light Suppression	Note8			TBD	Lux

Note 1 : Operation without IR-LED.

Note 2 :  $GAIN\_ALS[1:0] = 2'b00$ ,  $.IT\_ALS[3:0] = 4'b0010$ ,  $GAIN\_PS[1:0] = 2'b00$ ,  $.IT\_PS[3:0] = 4'b0000$ .

Note 3 : White LED parallel light source.

Note 4 :  $E_{ambient} = 0$  Lux.

Note 5 : The voltage of LDR pin is fixed at 1.2V.

Note 6 : I<sup>2</sup>C logical high voltage level is specified as worst-case condition when all of the recommended operation supply voltages ( $V_{DD}$ ) are taken into consideration. The logical high level is different when different supply voltage is applied.

Note 7 : I<sup>2</sup>C logical low voltage level is specified as worst-case condition when all of the recommended operation supply voltages ( $V_{DD}$ ) are taken into consideration. The logical low level is different when different supply voltage is applied.

Note 8 : Sunlight environment.

## 5.2 Timing Chart

### Characteristics of the SDA and SCL I/O

Symbol	Parameter	Standard Mode		Fast Mode		Unit
		Min.	Max.	Min.	Max.	
$f_{SCLK}$	SCL clock frequency	10	100	10	400	KHz
$t_{HDSTA}$	Hold time after (repeated) start condition. After this period, the first clock is generated	4.0	—	0.6	—	$\mu$ s
$t_{LOW}$	LOW period of the SCL clock	4.7	—	1.3	—	$\mu$ s
$t_{HIGH}$	HIGH period of the SCL clock	4.0	—	0.6	—	$\mu$ s
$t_{SUSTA}$	Set-up time for a repeated START condition	4.7	—	0.6	—	$\mu$ s
$t_{HDDAT}$	Data hold time	0	—	0	—	ns
$t_{SUDAT}$	Data set-up time	250	—	100	—	ns
$t_r$	Rise time of both SDA and SCL signals	—	1000	—	300	ns
$t_f$	Fall time of both SDA and SCL signals	—	300	—	300	ns
$t_{SUSTO}$	Set-up time for STOP condition	4.0	—	0.6	—	$\mu$ s
$t_{BUF}$	Bus free time between a STOP and START condition	4.7	—	1.3	—	$\mu$ s

Note 1:  $f_{SCLK}$  is the  $(t_{SCLK})^{-1}$ .

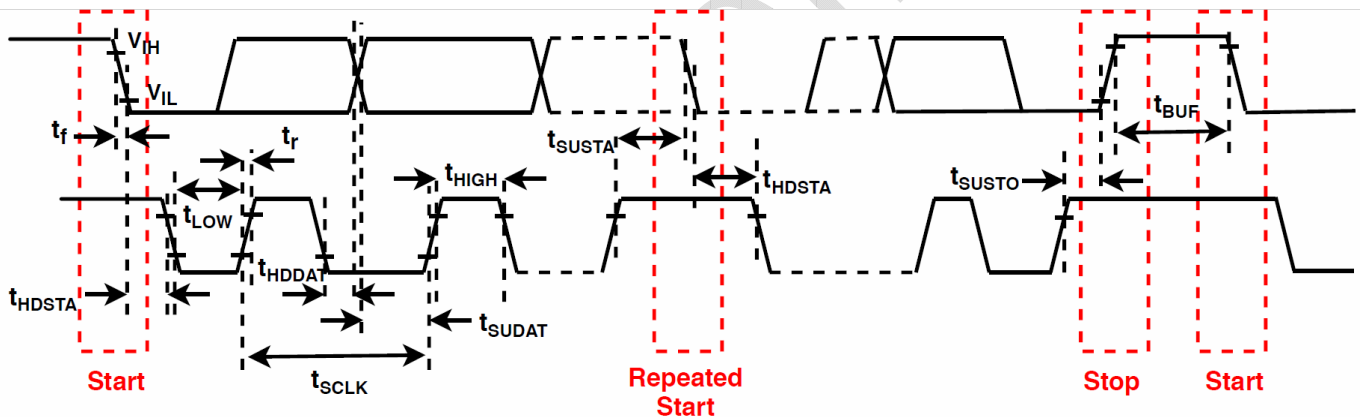

Timing Chart of the SDA and SCL

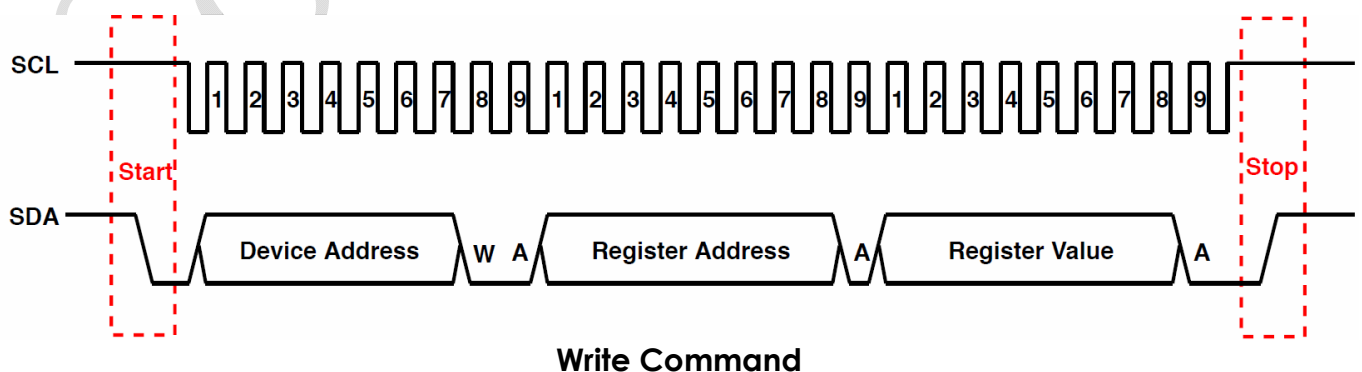

Write Command

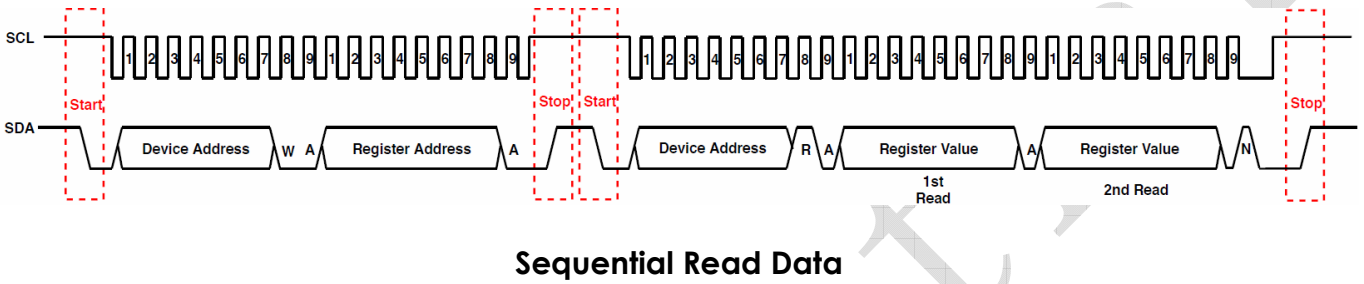
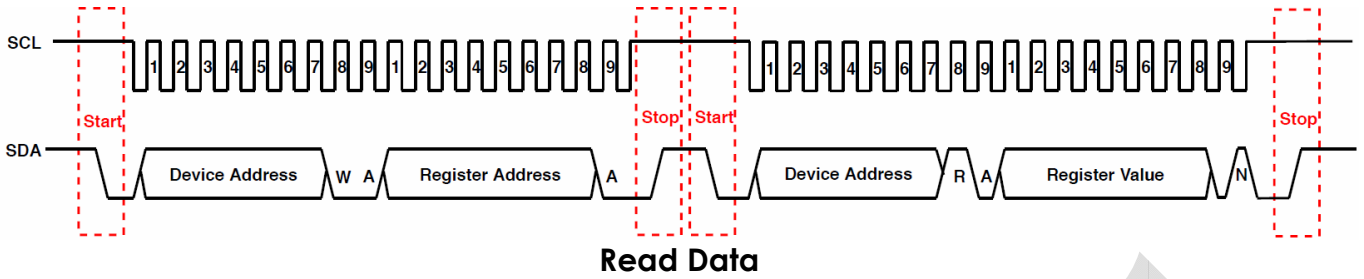

Confidential



## 6. FUNCTION DESCRIPTION

### 6.1 Digital Interface

STK32562 contains eight-bit registers accessed via the I<sup>2</sup>C bus. All operations can be controlled by the command register. The simple command structure makes user easy to program the operation setting and latch the output data from STK32562. Section 5.2 Timing chart displays the STK32562 I<sup>2</sup>C command format for reading and writing operation between host and STK32562.

STK32562 provides fixed I<sup>2</sup>C slave address of 0x46 using 7 bit addressing protocol.

Slave Address	R/W Command Bit	OPERATION
0x46	0	Write Command to STK32562
(followed by the R/W bit)	1	Read Data from STK32562

## 6.2 System Operation

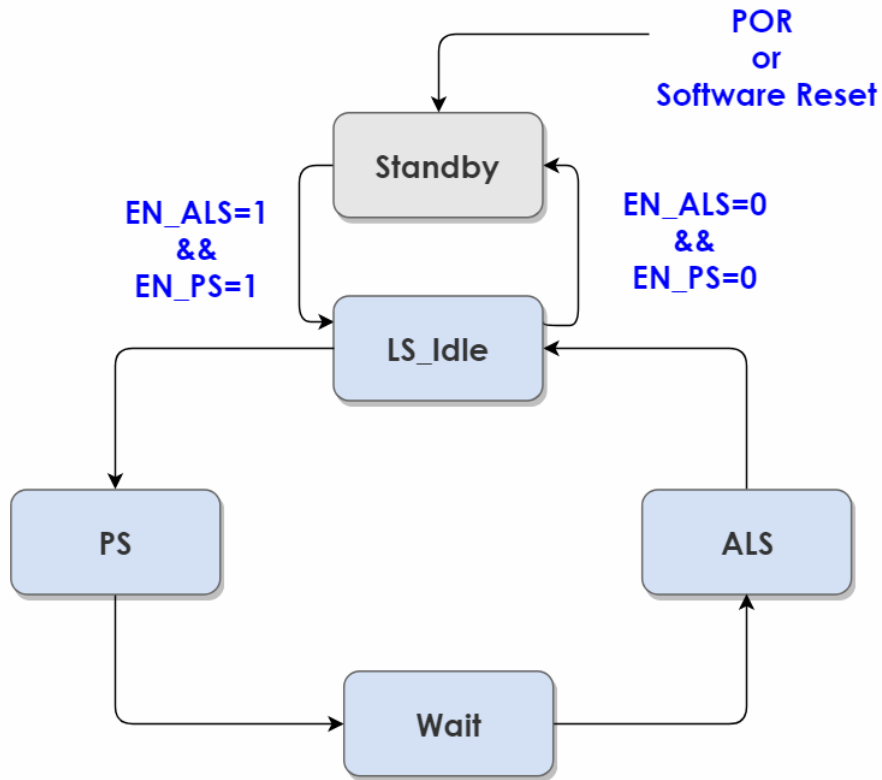

## 6.3 ALS Operation

### 6.3.1 ALS General Operation

The related ALS control bits are summarized below.

**ALS Control Bits**

<b>General Control</b>	
EN_ALS	Enable ALS sensing function
IT_ALS[3:0]	ALS integration time
GAIN_ALS[1:0]	ALS gain control
GAIN_ALS_DX128	ALS gain control specially for 128x
PRST_ALS[1:0]	ALS persistence number
GAIN_C[1:0]	Clear channel gain control
GAIN_C_DX128	Clear gain control specially for 128x
<b>ALS Interrupt Control</b>	
EN_ALS_INT	Enable ALS function interrupt
EN_ALS_DR_INT	Enable ALS data ready interrupt
THDH_ALS[15:0]	ALS out-of-windows high threshold
THDL_ALS[15:0]	ALS out-of-windows low threshold

**ALS Data/Status Bits**

<b>Data</b>	
DATA_ALS[15:0]	16-bits ALS channel raw data
DATA_C[15:0]	16-bits Clear channel raw data
<b>Status</b>	
FLG_ALS_DR	Indicate the ALS data ready event
FLG_ALS_INT	Indicate the Green channel out-of-windows event

STK32562 uses the coated photodiode array to measure the Lux of the incoming light and also an un-filtered clear photodiode array to improve the ALS sensing accuracy.

The ALS sensing function is enabled by the EN\_ALS bit and the gain control bit GAIN\_ALS[1:0], GAIN\_ALS\_DX128, GAIN\_C[1:0], GAIN\_C\_DX128 and IT period IT\_ALS[3:0] shall be set before the EN\_ALS.

The FLG\_ALS\_DR bit shall be asserted every ADC conversion cycle complete and shall be cleared automatically after one of the DATA\_ALS[15:0]/DATA\_C[15:0] is be read out through I<sup>2</sup>C.

The ALS/C data are 16-bit output and are stored in two bytes register. Higher byte register must be read first than lower byte. Data reading word protection is implemented to make sure the conversion data within the same conversion cycle could be read correctly. When the higher byte register is read, the lower 8-bit data will be stored into a shadow register which is read by the following sequential read or another single read to the lower byte register.

### 6.3.2 ALS Interrupt Description

#### **ALS Out-of-Windows Interrupt**

STK32562 provides the ALS data out-of-windows interrupt. Once the EN\_ALS\_INT is set to 1, then the STK32562 shall issue an ALS interrupt and assert the FLG\_ALS\_INT bit if the ALS data DATA\_ALS[15:0] are outside the user's programmed window defined by THDH\_ALS[15:0] and THDL\_ALS[15:0]. The FLG\_ALS\_INT shall be cleared by write the bit 0 and shall be reset to 0 if POR/SWRst or EN\_ALS = 0. Clear the EN\_ALS\_INT will also clear the FLG\_ALS\_INT bit to 0.

ALS persistence numbers PRST\_ALS[1:0] is used to avoid the false alarm of ALS out-of-windows event due to environment noise. If ALS persistence is set larger than 1, then the ALS out-of-windows interrupt will not be issued until continuous persistence numbers of ADC conversion results outside the defined windows.

#### **ALS Data Ready Interrupt**

STK32562 also provides the ALS data ready interrupt. Once the EN\_ALS\_DR\_INT is set to 1, then the STK32562 shall issue an ALS data ready interrupt every ADC conversion cycle and assert the FLG\_ALS\_DR bit. The FLG\_ALS\_DR shall be cleared automatically after any one of the DATA\_R/G/B/C[15:0] is be read out through I<sup>2</sup>C and shall be reset to 0 if POR/SWRst or EN\_ALS = 0. Clear the EN\_ALS\_DR\_INT will not influence the FLG\_ALS\_DR status.

## 6.4 PS Operation

### 6.4.1 PS General Operation

The related PS control bits are summarized below.

#### PS Control Bits

<b>General Control</b>	
EN_PS	Enable PS function
IT_PS[3:0]	PS integration time
GAIN_PS[1:0]	PS gain control
GAIN_PS_DX16	PS gain control specially for 16x
PRST_PS[1:0]	PS persistence number
DATA_PS_OFFSET[15:0]	PS digital offset cancellation
<b>LED Control</b>	
IRDR_LED[3:0]	Select LED driving current
<b>PS Interrupt Control</b>	
EN_PS_INT	Enable PS function interrupt
EN_PS_DR_INT	Enable PS data ready interrupt
PS_INT_MODE	Choose PS interrupt triggered mode.
PS_NF_MODE	Choose FLG_NF observed mode
THDH_PS[15:0]	PS near-far detect high threshold
THDL_PS[15:0]	PS near-far detect low threshold

#### PS Data/Status Bits

<b>Data</b>	
DATA_PS[15:0]	16-bits PS raw data
<b>Status</b>	
FLG_NF	Indicate the current object near/far state
FLG_PS_INT	Indicate the object near/far state changed event
FLG_PS_DR	Indicate the PS data ready event
FLG_INVALID_PS_INT	Indicate the PS data is invalid

The proximity function is used for object detection by IR-sensitivity photodiode detection of reflected IR energy emitted by the built-in IR LED.

The DATA\_PS[15:0] will be the ADC output subtract offset data defined in DATA\_PS\_OFFSET[15:0]. The PS data are 16-bit output and are stored in two bytes register. Higher byte register must be read first than lower byte. Data reading word protection is implemented to make sure the conversion data within the same conversion cycle could be read correctly. When the higher byte register is read, the lower 8-bit data will be stored into a shadow register which is read by the following sequential read or another single read to the lower byte register.

The FLG\_NF is used to indicate the current object is in near or far state and persistence is also applied to this flag if PRST\_PS > 1.

The FLG\_PS\_DR bit shall be asserted every ADC conversion cycle complete and shall be cleared automatically after the DATA\_PS[15:0] is be read out through I<sup>2</sup>C.

IRDR\_LED[3:0] is used to choose different LED constant driving current. STK32562 has 11 different LED current levels 3.125/6.25/12.5/25/50/75/100/125/150/175/200 mA

## 6.4.2 PS Interrupt Description

The EN\_PS\_INT[0] register is used to control PS interrupt function for enable or disable

The PS\_NF\_MODE[1] register is used to select how STK32562 reports the object near/far state to application.

The PS\_INT\_MODE[2] register is PS interrupt modes for near/far state change are described as below.

### **PS INT Function (EN\_PS\_INT[0] = 1'b0) & PS Near/Far Flag Mode (PS\_NF\_Mode[1] = 1'b0)**

If EN\_PS\_INT[0] is set to 1'b0, then the polling mode is used and the INT pin is non-active when near/far event detected. In this mode, the INT output level is fixed to pull-high and the FLG\_PS\_INT will never be asserted. The application simply polls the FLG\_NF to check the object in near or far state.

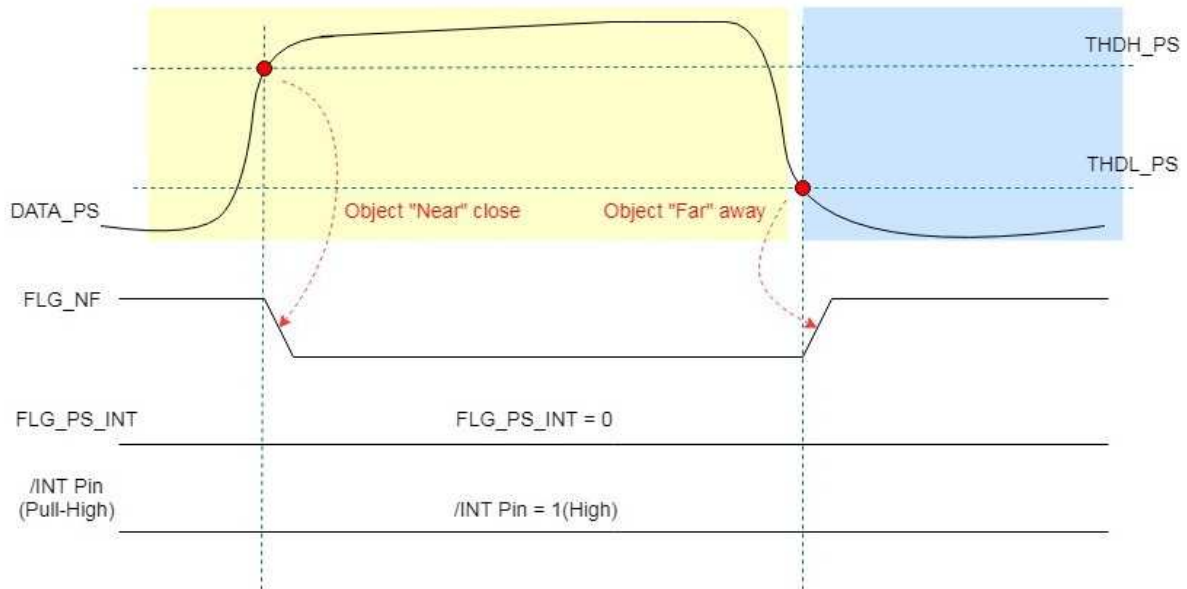

### PS INT Function (EN\_PS\_INT[0] = 1'b1) & PS Near/Far Flag Mode (PS\_NF\_Mode[1] = 1'b0)

The INT pin is treated as interrupt signal. The FLG\_NF is used to indicate whether the object is in near or far state. The STK32562 is default in object far state and the FLG\_NF = 1. Once the object moving close to the STK32562 and PS code exceed the high threshold THDH\_PS, STK32562 will switch to object near state and the FLG\_NF is cleared to 0. STK32562 will issue a PS interrupt to inform the object near/far state changed and also set the FLG\_PS\_INT to 1. If the object move far away from the STK32562 and PS code lower than the low threshold THDL\_PS, STK32562 will switch to object far state and the FLG\_NF is set to 1. STK32562 will also issue a PS interrupt to inform and set FLG\_PS\_INT. The FLG\_PS\_INT shall be cleared by write the bit 0 and shall be reset to 0 if POR/SWRst or EN\_PS = 0. The FLG\_NF shall be reset to 1 if POR/SWRst or EN\_PS = 0. Change the PS\_MODE will also clear the FLG\_PS\_INT to 0, but keep the current PS code and FLG\_NF state.

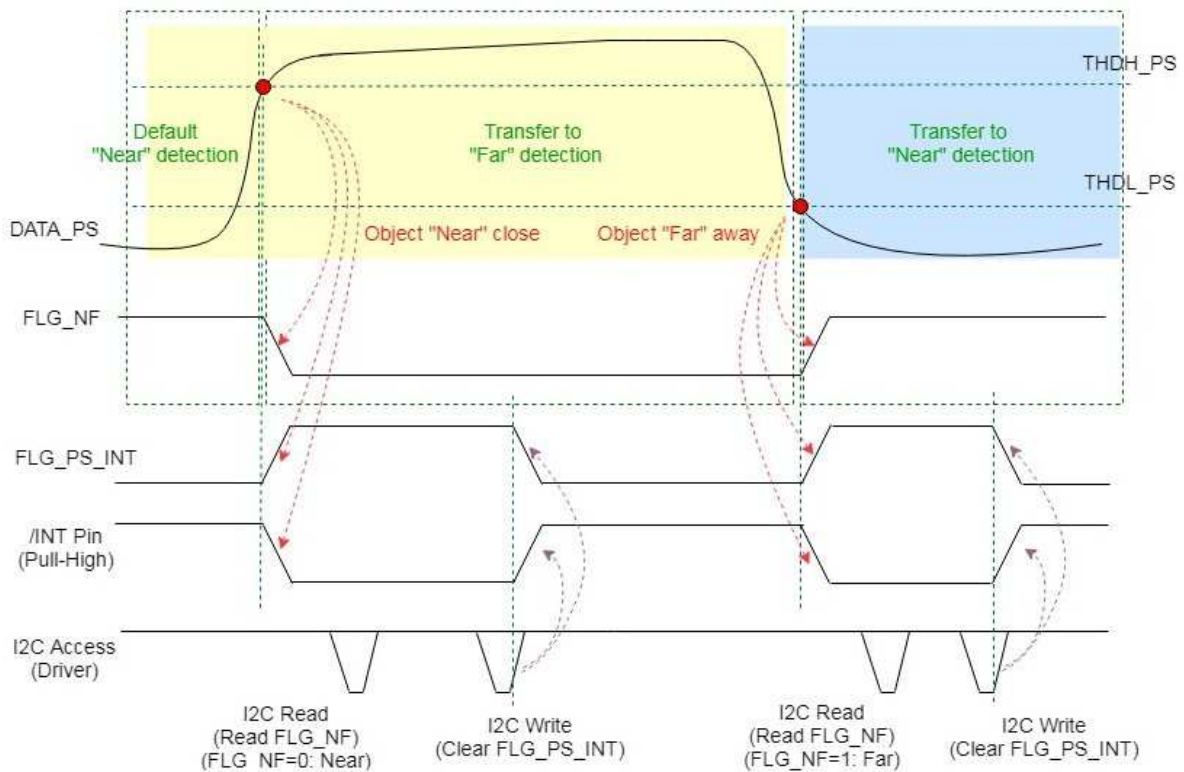

PS persistence numbers PRST\_PS[1:0] is used to avoid the false alarm of PS interrupt event due to environment noise. If PS persistence is set larger than 1, then the PS interrupt will not be issued until continuous persistence numbers of ADC conversion results meet the interrupt condition describe above.

For example:

(1) PRST\_PS[1:0] = 2'b01 (x2), EN\_ALS = 1, EN\_PS = 1, EN\_WAIT = 1

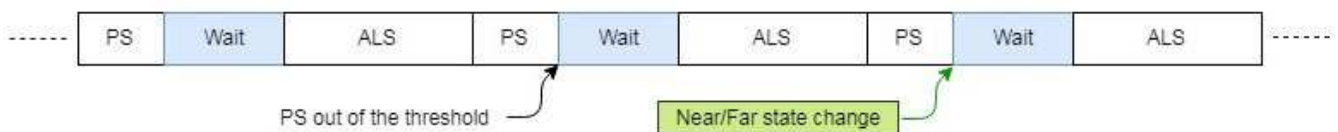

(2) PRST\_PS[1:0] = 2'b01 (x2), EN\_ALS = 1, EN\_PS = 1, EN\_WAIT = 1, and fail to issue interrupt event (no continue persistence numbers of PS ADC conversion results is out of threshold),

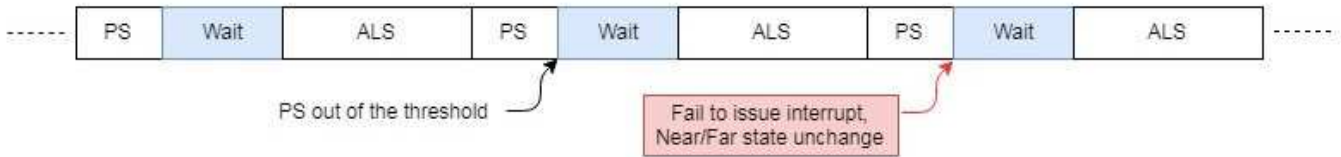

### PS INT Function (EN\_PS\_INT[0] = 1'b1) & PS Near/Far Flag Mode (PS\_NF\_Mode[1] = 1'b1)

If PS\_NF\_MODE[1] = 1'b1, then the polling mode is used and the INT pin is treated as a near/far flag signal, not an interrupt signal. In this mode, the INT output level is same with the FLG\_NF signal level and the FLG\_PS\_INT will never be asserted. The application simply polls the INT level (high or low) to check the object in near or far state. INT Pin is only from PS FLG\_NF, and the ALS interrupt, Invalid PS interrupt is ignored.

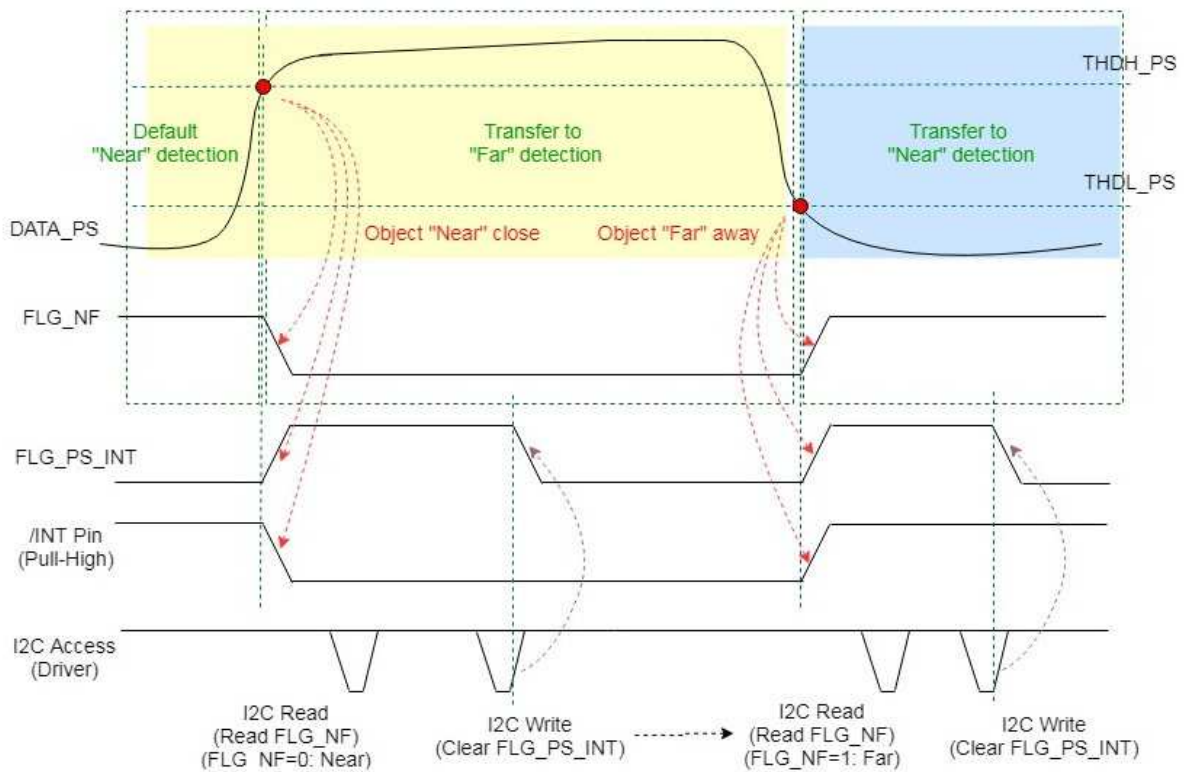

### PS Data Ready Interrupt

STK32562 provides the PS data ready interrupt. Once the EN\_PS\_DR\_INT is set to 1, then the STK32562 shall issue a PS data ready interrupt every ADC conversion cycle and assert the FLG\_PS\_DR bit. The FLG\_PS\_DR shall be cleared automatically after the DATA\_PS[15:0] is be read out through I<sup>2</sup>C and shall be reset to 0 if POR/SWRst or EN\_PS = 0. Clear the EN\_PS\_DR\_INT will not influence the FLG\_PS\_DR status.

## 6.5 Wait State Operation

### 6.5.1 Wait State General Operation

The related Wait control bits are summarized below.

<b>Wait Control Bits</b>	
<b>General Control</b>	
EN_WAIT	Enable Wait state
WAIT[7:0]	Wait period

Wait state is used for power saving



## 7. CONTROL REGISTER MAP

ADDR	REG NAME	BIT								Default
		7	6	5	4	3	2	1	0	
0x00	<a href="#">STATE</a>						EN_WAIT	EN_ALS	EN_PS	0x00
0x01	<a href="#">PSCTRL</a>	PRST_PS[1:0]		GAIN_PS[1:0]		IT_PS[3:0]				0x00
0x02	<a href="#">ALSCTRL1</a>	PRST_ALS[1:0]		GAIN_ALS[1:0]		IT_ALS[3:0]				0x02
0x03	<a href="#">LEDCTRL</a>	IRDR_LED[3:0]								0x60
0x04	<a href="#">INTCTRL1</a>	INT_CTRL		EN_INVALID_PS_INT		EN_ALS_INT	PS_INT_MODE	PS_NF_MODE	EN_PS_INT	0x00
0x05	<a href="#">WAIT</a>	WAIT[7:0]								0x00
0x06	<a href="#">THDH1_PS</a>	THDH_PS[15:8]								0xFF
0x07	<a href="#">THDH2_PS</a>	THDH_PS[7:0]								0xFF
0x08	<a href="#">THDL1_PS</a>	THDL_PS[15:8]								0x00
0x09	<a href="#">THDL2_PS</a>	THDL_PS[7:0]								0x00
0x0A	<a href="#">THDH1_ALS</a>	THDH_ALS[15:8]								0xFF
0x0B	<a href="#">THDH2_ALS</a>	THDH_ALS[7:0]								0xFF
0x0C	<a href="#">THDL1_ALS</a>	THDL_ALS[15:8]								0x00
0x0D	<a href="#">THDL2_ALS</a>	THDL_ALS[7:0]								0x00
0x10	<a href="#">FLAG</a>	FLG_ALS_DR	FLG_PS_DR	FLG_ALS_INT	FLG_PS_INT		FLG_ALS_STAT	FLG_INVALID_PS_INT	FLG_NF	0x01
0x11	<a href="#">DATA1_PS</a>	DATA_PS[15:8]								0x00
0x12	<a href="#">DATA2_PS</a>	DATA_PS[7:0]								0x00
0x13	<a href="#">DATA1_ALS</a>	DATA_ALS[15:8]								0x00
0x14	<a href="#">DATA2_ALS</a>	DATA_ALS[7:0]								0x00
0x17	<a href="#">DATA1_ALS1</a>	DATA_ALS1[15:8]								0x00
0x18	<a href="#">DATA2_ALS1</a>	DATA_ALS1[7:0]								0x00
0x1B	<a href="#">DATA1_C</a>	DATA_C[15:8]								0x00
0x1C	<a href="#">DATA2_C</a>	DATA_C[7:0]								0x00
0x1D	<a href="#">DATA1_PS_OFFSET</a>	DATA_PS_OFFSET[15:8]								0x00
0x1E	<a href="#">DATA2_PS_OFFSET</a>	DATA_PS_OFFSET[7:0]								0x00
0x3E	<a href="#">PDT_ID</a>	PDT_ID[7:0]								0x52
0x3F	<a href="#">Reserved</a>	Reserved								
0x4E	<a href="#">GAINCTRL</a>			GAIN_C[1:0]			GAIN_C_DX128	GAIN_ALS_DX128	GAIN_PS_DX16	0x00
0x80	<a href="#">SOFT_RESET</a>	Write any to soft reset								0x00
0xA1	<a href="#">PDCTRL</a>		ALS_SEL				PS_SEL			0x7F
0xA5	<a href="#">INTCTRL2</a>							EN_ALS_DR_INT	EN_PS_DR_INT	0x00

### STATE Register (0x00)

Bit	7	6	5	4	3	2	1	0
ITEM						EN_WAIT	EN_ALS	EN_PS
Access						R/W	R/W	R/W
Default						0	0	0

Bit	ITEM	Description
0	EN_PS	Enable the PS function. 0 : Disable 1 : Enable
1	EN_ALS	Enable the ALS/C function. 0 : Disable 1 : Enable
2	EN_WAIT	Enable the Wait state. 0 : Disable 1 : Enable

### PSCTRL Register (0x01)

Bit	7	6	5	4	3	2	1	0
ITEM	PRST_PS[1:0]		GAIN_PS[1:0]		IT_PS[3:0]			
Access	R/W		R/W		R/W			
Default	2'b00		2'b00		4'b0000			

Bit	ITEM	Description																
3:0	IT_PS[3:0]	PS integration time. <table border="1"> <tr><td>4'b0000</td><td>96 us</td></tr> <tr><td>4'b0001</td><td>192 us</td></tr> <tr><td>4'b0010</td><td>384 us</td></tr> <tr><td>4'b0011</td><td>768 us</td></tr> <tr><td>4'b0100</td><td>1.54 ms</td></tr> <tr><td>4'b0101</td><td>3.07 ms</td></tr> <tr><td>4'b0110</td><td>6.14 ms</td></tr> <tr><td>others</td><td>Reserved</td></tr> </table>	4'b0000	96 us	4'b0001	192 us	4'b0010	384 us	4'b0011	768 us	4'b0100	1.54 ms	4'b0101	3.07 ms	4'b0110	6.14 ms	others	Reserved
4'b0000	96 us																	
4'b0001	192 us																	
4'b0010	384 us																	
4'b0011	768 us																	
4'b0100	1.54 ms																	
4'b0101	3.07 ms																	
4'b0110	6.14 ms																	
others	Reserved																	
5:4	GAIN_PS[1:0]	PS gain setting. <table border="1"> <tr><td>2'b00</td><td>x 1 times</td></tr> <tr><td>2'b01</td><td>x 2 times</td></tr> <tr><td>2'b10</td><td>x 4 times</td></tr> <tr><td>2'b11</td><td>x 8 times</td></tr> </table>	2'b00	x 1 times	2'b01	x 2 times	2'b10	x 4 times	2'b11	x 8 times								
2'b00	x 1 times																	
2'b01	x 2 times																	
2'b10	x 4 times																	
2'b11	x 8 times																	
7:6	PRST_PS[1:0]	PS persistence setting. The PS has an interrupt persistence filter. The persistence filter allows user to specify the number of consecutive out-of-threshold PS occurrences before an interrupt is triggered. <table border="1"> <tr><td>2'b00</td><td>x 1 times</td></tr> <tr><td>2'b01</td><td>x 2 times</td></tr> <tr><td>2'b10</td><td>x 4 times</td></tr> <tr><td>2'b11</td><td>x 8 times</td></tr> </table>	2'b00	x 1 times	2'b01	x 2 times	2'b10	x 4 times	2'b11	x 8 times								
2'b00	x 1 times																	
2'b01	x 2 times																	
2'b10	x 4 times																	
2'b11	x 8 times																	

**ALSCTRL1 Register (0x02)**

Bit	7	6	5	4	3	2	1	0
ITEM	PRST_ALS[1:0]		GAIN_ALS[1:0]		IT_ALS[3:0]			
Access	R/W		R/W		R/W			
Default	2'b00		2'b00		4'b0010			

Bit	ITEM	Description																
3:0	IT_ALS[3:0]	ALS integration time. <table border="1"> <tr><td>4'b0000</td><td>25 ms</td></tr> <tr><td>4'b0001</td><td>50 ms</td></tr> <tr><td>4'b0010</td><td>100 ms</td></tr> <tr><td>4'b0011</td><td>200 ms</td></tr> <tr><td>4'b0100</td><td>400 ms</td></tr> <tr><td>4'b0101</td><td>800 ms</td></tr> <tr><td>4'b0110</td><td>1600 ms</td></tr> <tr><td>others</td><td>Reserved</td></tr> </table>	4'b0000	25 ms	4'b0001	50 ms	4'b0010	100 ms	4'b0011	200 ms	4'b0100	400 ms	4'b0101	800 ms	4'b0110	1600 ms	others	Reserved
4'b0000	25 ms																	
4'b0001	50 ms																	
4'b0010	100 ms																	
4'b0011	200 ms																	
4'b0100	400 ms																	
4'b0101	800 ms																	
4'b0110	1600 ms																	
others	Reserved																	
5:4	GAIN_ALS[1:0]	ALS gain setting. GAIN_ALS[1:0] is used to control of the ALS channels signal gain. The Clear channel is controlled by GAIN_C[1:0]. <table border="1"> <tr><td>2'b00</td><td>x 1 times</td></tr> <tr><td>2'b01</td><td>x 4 times</td></tr> <tr><td>2'b10</td><td>x 16 times</td></tr> <tr><td>2'b11</td><td>x 64 times</td></tr> </table>	2'b00	x 1 times	2'b01	x 4 times	2'b10	x 16 times	2'b11	x 64 times								
2'b00	x 1 times																	
2'b01	x 4 times																	
2'b10	x 16 times																	
2'b11	x 64 times																	
7:6	PRST_ALS[1:0]	ALS persistence setting. The ALS has an interrupt persistence filter. The persistence filter allows user to specify the number of consecutive out-of-windows ALS occurrences before an interrupt is triggered. <table border="1"> <tr><td>2'b00</td><td>x 1 times</td></tr> <tr><td>2'b01</td><td>x 2 times</td></tr> <tr><td>2'b10</td><td>x 4 times</td></tr> <tr><td>2'b11</td><td>x 8 times</td></tr> </table>	2'b00	x 1 times	2'b01	x 2 times	2'b10	x 4 times	2'b11	x 8 times								
2'b00	x 1 times																	
2'b01	x 2 times																	
2'b10	x 4 times																	
2'b11	x 8 times																	

BIT[3:0]	REFRESH TIME	Multiple of Base Refresh Time	Lux/LSB under GAIN_ALS=2'11 (64x)
0000	25ms	x1	TBD
0001	50ms	x2	TBD
0010	100ms	x4	TBD
0011	200ms	x8	TBD
0100	400ms	x16	TBD
0101	800ms	x32	TBD
0110	1600ms	x64	TBD

BIT[5:4]	Gain	LUX/LSB under IT_ALS=4'b0010 (100ms)
00	x1	TBD
01	x4	TBD
10	x16	TBD
11	x64	TBD

### LEDCTRL Register (0x03)

Bit	7	6	5	4	3	2	1	0
ITEM	IRDR_LED[3:0]							
Access	R/W							
Default	4'b0110							

Bit	ITEM	Description
7:4	IRDR_LED[3:0]	LED constant current setting. The STK32562 provides different sinking ability for IRLED through setting IRDR.
		4'b0000 3.125 mA current sink
		4'b0001 6.25 mA current sink
		4'b0010 12.5 mA current sink
		4'b0011 25 mA current sink
		4'b0100 50 mA current sink
		4'b0101 75 mA current sink
		4'b0110 100 mA current sink
		4'b0111 125 mA current sink
		4'b1000 150 mA current sink
		4'b1001 175 mA current sink
		4'b1010 200 mA current sink

### INTCTRL1 Register (0x04)

Bit	7	6	5	4	3	2	1	0
ITEM	INT_CTRL		EN_INVALID_PS_INT		EN_ALS_INT	PS_INT_MODE	PS_NF_MODE	EN_PS_INT
Access	R/W		R/W		R/W	R/W	R/W	R/W
Default	0		0		0	0	0	0

Bit	ITEM	Description
0	EN_PS_INT	Enable the PS interrupt
1	PS_NF_MODE	Choose FLG_NF observed mode. 0 : FLG_NF could be observed from FLAG[0] 1 : FLG_NF could be observed through INT
2	PS_INT_MODE	Choose PS interrupt triggered mode. 0 : PS interrupt is triggered by FLG_NF change 1 : PS interrupt is triggered by PS data out of window
3	EN_ALS_INT	Enable the ALS out-of-windows interrupt. 0 : Disable 1 : Enable
5	EN_INVALID_PS_INT	Enable the Invalid PS interrupt. 0 : Disable 1 : Enable
7	INT_CTRL	0 : Set /INT pin low if FLG_ALS_INT or FLG_ALS_DR or FLG_PS_INT or FLG_PS_DR or FLG_POCKET_MODE_INT or FLG_INVALID_PS_INT high 1 : Set /INT pin low if (FLG_ALS_INT and FLG_PS_INT) or FLG_ALS_DR or FLG_PS_DR high or FLG_POCKET_MODE_INT or FLG_INVALID_PS_INT high

**WAIT Register (0x05)**

Bit	7	6	5	4	3	2	1	0
ITEM	WAIT[7:0]							
Access	R/W							
Default	8'b00000000							

Bit	ITEM	Description
7:0	WAIT[7:0]	PS/GS wait state period. wait period = (WAIT[7:0] + 1) * 1.54 ms

**THDH1 PS Register (0x06)**

Bit	7	6	5	4	3	2	1	0
ITEM	THDH_PS[15:8]							
Access	R/W							
Default	8'b11111111							

**THDH2 PS Register (0x07)**

Bit	7	6	5	4	3	2	1	0
ITEM	THDH_PS[7:0]							
Access	R/W							
Default	8'b11111111							

**THDL1 PS Register (0x08)**

Bit	7	6	5	4	3	2	1	0
ITEM	THDL_PS[15:8]							
Access	R/W							
Default	8'b00000000							

**THDL2 PS Register (0x09)**

Bit	7	6	5	4	3	2	1	0
ITEM	THDL_PS[7:0]							
Access	R/W							
Default	8'b00000000							

Bit	ITEM	Description
15:0	THDH_PS[15:0]	PS high threshold.
15:0	THDL_PS[15:0]	PS low threshold.

**THDH1 ALS Register (0x0A)**

Bit	7	6	5	4	3	2	1	0
ITEM	THDH_ALS[15:8]							
Access	R/W							
Default	8'b11111111							

**THDH2 ALS Register (0x0B)**

Bit	7	6	5	4	3	2	1	0
ITEM	THDH_ALS[7:0]							
Access	R/W							
Default	8'b11111111							

**THDL1 ALS Register (0x0C)**

Bit	7	6	5	4	3	2	1	0
ITEM	THDL_ALS[15:8]							
Access	R/W							
Default	8'b00000000							

**THDL2 ALS Register (0x0D)**

Bit	7	6	5	4	3	2	1	0
ITEM	THDL_ALS[7:0]							
Access	R/W							
Default	8'b00000000							

Bit	ITEM	Description
15:0	THDH_ALS[15:0]	ALS high threshold.
15:0	THDL_ALS[15:0]	ALS low threshold.

**FLAG Register (0x10)**

Bit	7	6	5	4	3	2	1	0
ITEM	FLG_ALS_DR	FLG_PS_DR	FLG_ALS_INT	FLG_PS_INT		FLG_ALS_SAT	FLG_INVALID_PS_INT	FLG_NF
Access	R/W	R/W	R/W	R/W		RO	R/W	RO
Default	0	0	0	0		0	0	1

Bit	ITEM	Description
0	FLG_NF	Object near/far flag. Default FLG_NF = 1, object in far state. 0 : Object in near state 1 : Object in far state
1	FLG_INVALID_PS_INT	Indicate if interrupt event is related to INVALID_PS_INT. Write bit 0 to clear. 0 : No INVALID_PS_INT event

		1 : INVALID_PS_INT event
2	FLG_ALS_SAT	Indicate the ALS channel circuit saturation. 0 : No ALS channel circuit saturation, the data is valid. 1 : ALS channel circuit saturation, the data is not valid.
4	FLG_PS_INT	Indicate if interrupt event is related to PS_INT. Write bit 0 to clear. 0 : No PS_INT event 1 : PS_INT event
5	FLG_ALS_INT	Indicate if interrupt event is related to ALS_INT. Write bit 0 to clear. 0 : No ALS_INT event 1 : ALS_INT event
6	FLG_PS_DR	Indicate PS data conversion complete. Automatically cleared after DATA_PS[15:0] is read. 0: PS data is not ready 1: PS data is ready
7	FLG_ALS_DR	Indicate ALS data conversion complete. Automatically cleared after DATA_ALS[15:0] is read. 0: ALS data is not ready 1: ALS data is ready

#### DATA1 PS Register (0x11)

Bit	7	6	5	4	3	2	1	0
ITEM	DATA_PS[15:8]							
Access	RO							
Default	8'b00000000							

#### DATA2 PS Register (0x12)

Bit	7	6	5	4	3	2	1	0
ITEM	DATA_PS[7:0]							
Access	RO							
Default	8'b00000000							

The STK32562 has two 8-bit read-only registers to hold the data from ADC of PS. The most significant bit (MSB) is accessed at register 0x11, and the least significant bit (LSB) is accessed at register 0x12. The registers are updated for every PS integration time (conversion cycle).

### DATA1 ALS Register (0x13)

Bit	7	6	5	4	3	2	1	0
ITEM	DATA_ALS[15:8]							
Access	RO							
Default	8'b00000000							

### DATA2 ALS Register (0x14)

Bit	7	6	5	4	3	2	1	0
ITEM	DATA_ALS[7:0]							
Access	RO							
Default	8'b00000000							

### DATA1 ALS1 Register (0x17)

Bit	7	6	5	4	3	2	1	0
ITEM	DATA_ALS1[15:8]							
Access	RO							
Default	8'b00000000							

### DATA2 ALS1 Register (0x18)

Bit	7	6	5	4	3	2	1	0
ITEM	DATA_ALS1[7:0]							
Access	RO							
Default	8'b00000000							

### DATA1 C Register (0x1B)

Bit	7	6	5	4	3	2	1	0
ITEM	DATA_C[15:8]							
Access	RO							
Default	8'b00000000							

### DATA2 C Register (0x1C)

Bit	7	6	5	4	3	2	1	0
ITEM	DATA_C[7:0]							
Access	RO							
Default	8'b00000000							

The STK32562 has two 8-bit read-only registers to hold each data from ADC of ALS/C. The registers are updated for every ALS/C integration time (conversion cycle).



### DATA1 PS OFFSET Register (0x1D)

Bit	7	6	5	4	3	2	1	0
ITEM	DATA_PS_OFFSET[15:8]							
Access	RW							
Default	8'b00000000							

### DATA2 PS OFFSET Register (0x1E)

Bit	7	6	5	4	3	2	1	0
ITEM	DATA_PS_OFFSET[7:0]							
Access	RW							
Default	8'b00000000							

### Product ID (0x3E)

Read Only; PDT\_ID = Product ID(0x52) to indicate the product information.

### Reserved (0x3F)

Read Only; RSRVD = Reserved for engineering mode.

### GAINCTRL Register (0x4E)

Bit	7	6	5	4	3	2	1	0
ITEM			GAIN_C[1:0]			GAIN_C_D DX128	GAIN_AL S_DX128	GAIN_PS _DX16
Access			R/W			R/W	R/W	R/W
Default			2'b00			0	0	0

Bit	ITEM	Description								
0	GAIN_PS_DX16	GAIN_PS_DX16 is used to control specially for PS channel 16x gain.								
1	GAIN_ALS_DX128	GAIN_ALS_DX128 is used to control specially for ALS channel 128x gain.								
2	GAIN_C_DX128	GAIN_C_DX128 is used to control specially for Clear channel 128x gain.								
5:4	GAIN_C[1:0]	Clear channel gain setting. GAIN_C[1:0] is used to control of the Clear channel signal gain. The ALS are controlled by GAIN_ALS[1:0].								
		<table border="1"> <tr> <td>2'b00</td> <td>x 1 times</td> </tr> <tr> <td>2'b01</td> <td>x 4 times</td> </tr> <tr> <td>2'b10</td> <td>x 16 times</td> </tr> <tr> <td>2'b11</td> <td>x 64 times</td> </tr> </table>	2'b00	x 1 times	2'b01	x 4 times	2'b10	x 16 times	2'b11	x 64 times
2'b00	x 1 times									
2'b01	x 4 times									
2'b10	x 16 times									
2'b11	x 64 times									

### Soft reset (0x80)

Write any data to this register will reset the chip.

**PSPDCTRL Register (0xA1)**

Bit	7	6	5	4	3	2	1	0
ITEM		ALS_ALS0	ALS_ALS1	ALS_ALS2	PS_PS3	PS_PS2	PS_PS1	PS_PS0
Access		R/W	R/W	R/W	R/W	R/W	R/W	R/W
Default		1	1	1	1	1	1	1

Bit	ITEM	Description
0	PS_PS0	Enable the PS0 PD . 0 : Disable 1 : Enable
1	PS_PS1	Enable the PS1 PD . 0 : Disable 1 : Enable
2	PS_PS2	Enable the PS2 PD . 0 : Disable 1 : Enable
3	PS_PS3	Enable the PS3 PD . 0 : Disable 1 : Enable
4	ALS_ALS0	Enable the Red PD . 0 : Disable 1 : Enable
5	ALS_ALS1	Enable the Green PD . 0 : Disable 1 : Enable
6	ALS_ALS2	Enable the Blue PD . 0 : Disable 1 : Enable

**INTCTRL2 Register (0xA5)**

Bit	7	6	5	4	3	2	1	0
ITEM							EN_ALS_DR_INT	EN_PS_D_R_INT
Access							R/W	R/W
Default							0	0

Bit	ITEM	Description
0	EN_PS_DR_INT	Enable the PS Data Ready interrupt. 0 : Disable 1 : Enable
1	EN_ALS_DR_INT	Enable the ALS Data Ready interrupt. 0 : Disable 1 : Enable

## 8. ALS RESPONSE CHARTS

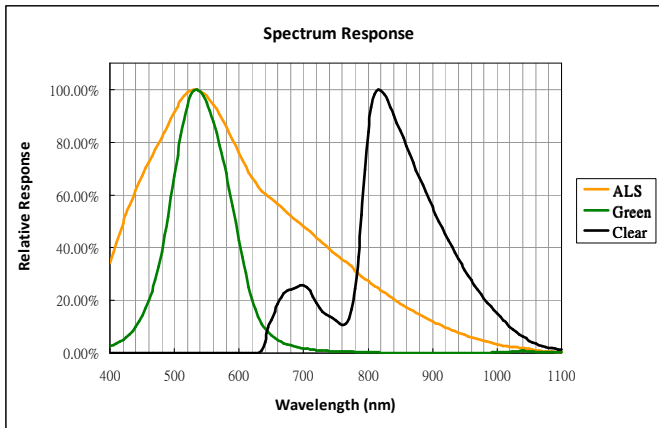

**Spectrum**

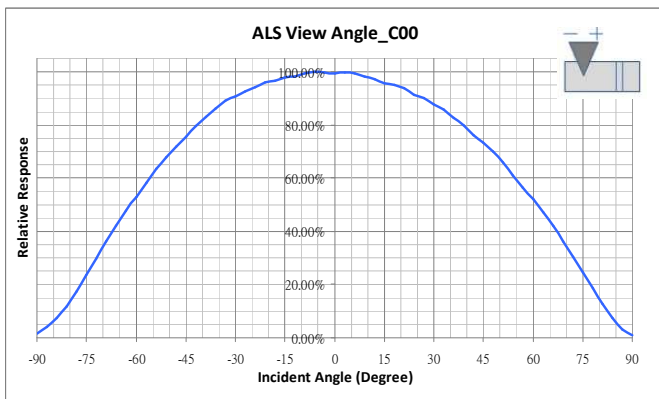

**ALS C00 Angular Response**

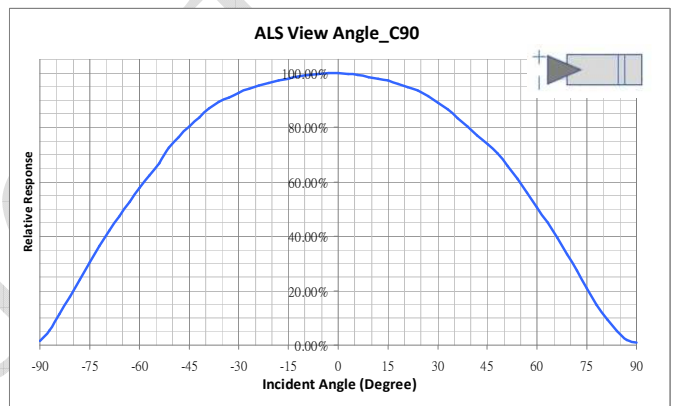

**ALS C90 Angular Response**

## 9. PROXIMITY RESPONSE CHARTS

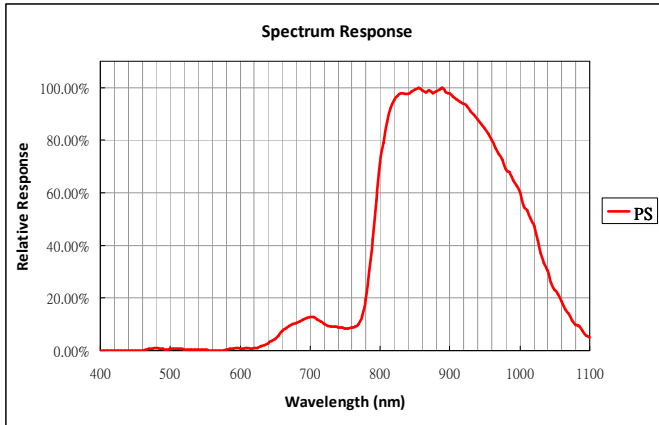

**Spectrum**

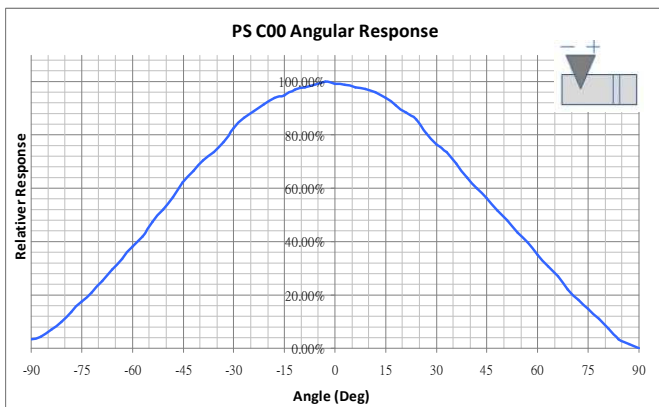

**PS C00 Angular Response**

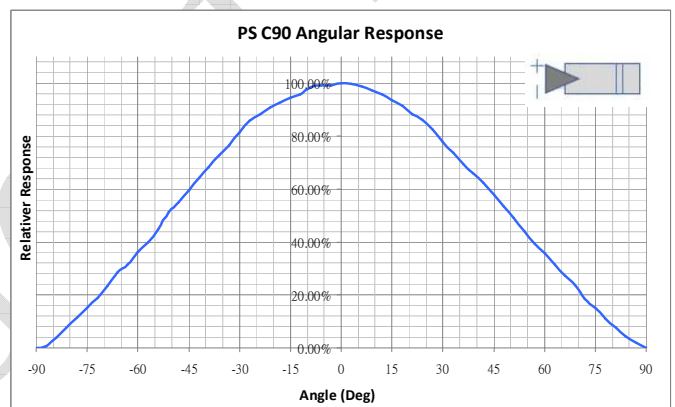

**PS C90 Angular Response**

## 10. APPLICATION NOTE

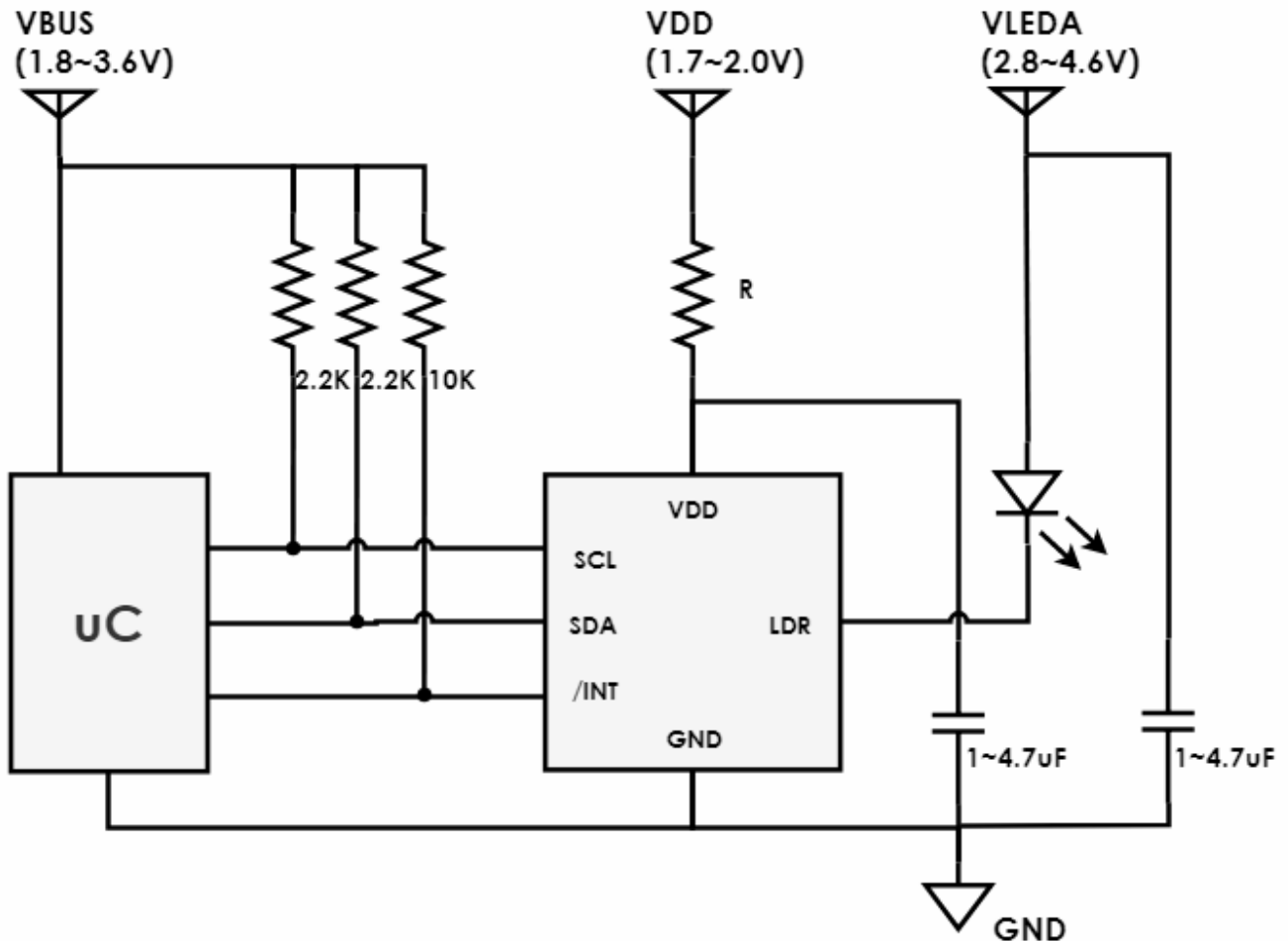

STK32562 Typical Application Circuit with Independent VDD and VLED Supply Voltage

### 10.1 Power Noise Consideration

It is suggested that IC power and  $V_{LED}$  comes from individual source to get the best performance of STK32562 and an R/C low pass filter is also suggested to be added in the  $V_{DD}$  path of STK32562 to reduce the switching noise from whole system. The recommended R value is 22 Ohm.

## 10.2 Power ON Sequence

The  $t_1$  is must over 30ms (VDD is recommended first), and suggested that  $t_2 \geq 0$ .  
 VDD variation peak=100mV (+/-50mV).  
 VLEDA variation peak=200mV (+/-100mV).

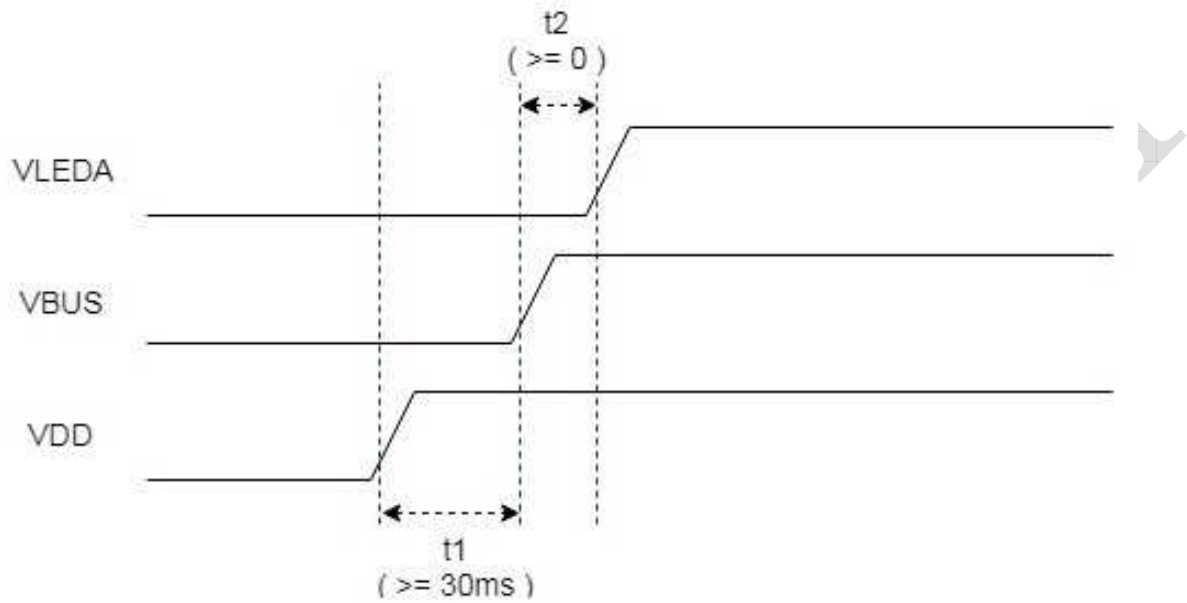

Confidential

## 11. PACKAGE OUTLINE

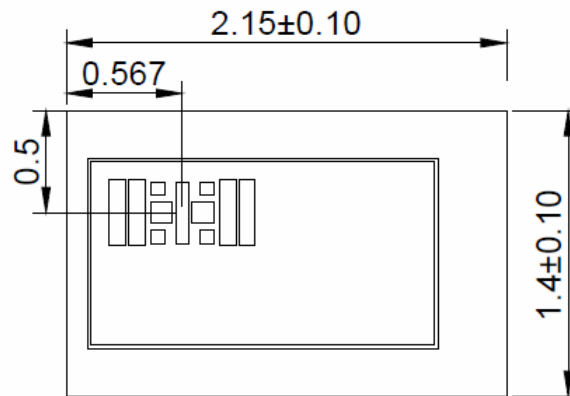
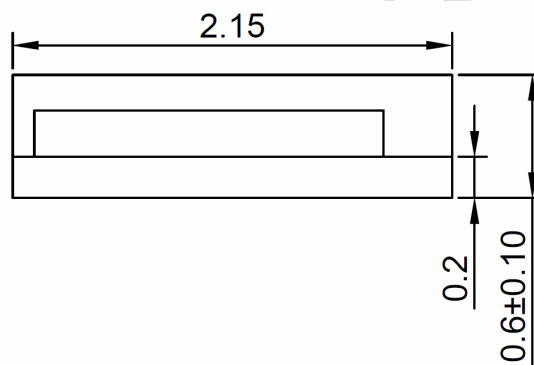
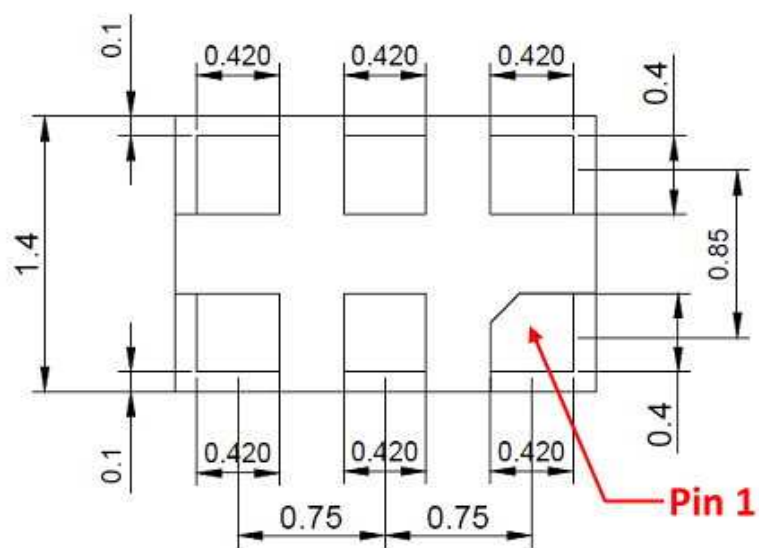
**Top View**

**Side View**

**Bottom View**

## PCB Pad Layout and Solder Mask Define Recommendation

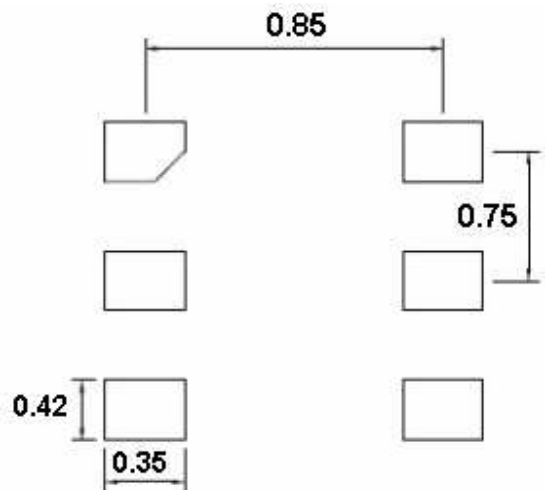
Suggested PCB pad layout guidelines are shown below.

PCB Pad Layout



Solder Mask Define

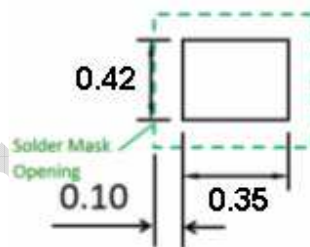

Notes: all linear dimensions are in mm.



## 12. SOLDERING INFORMATION

### 12.1 Soldering Condition

0. Pb-free solder temperature profile

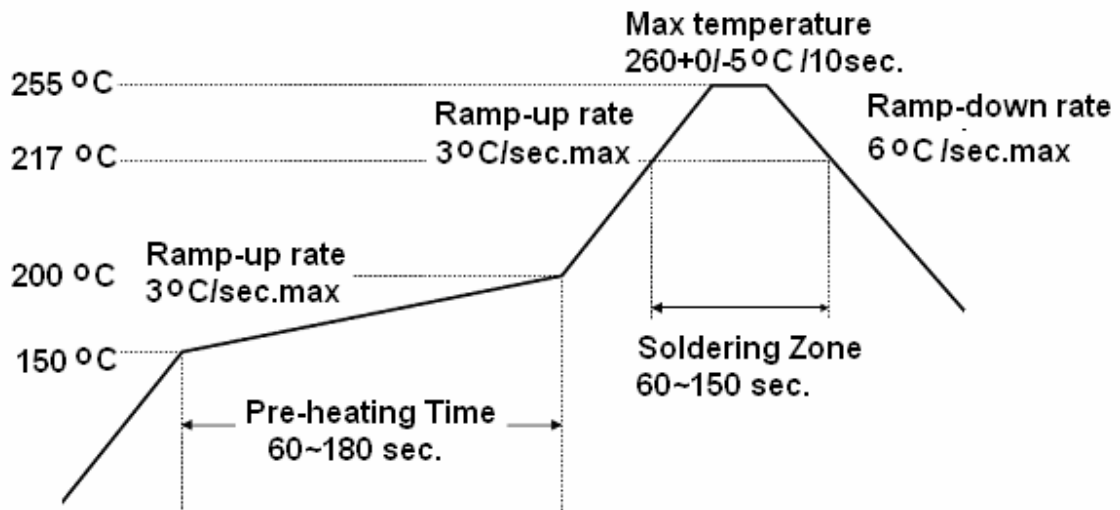

2. Reflow soldering should not be done more than three times.
3. When soldering, do not put stress on the lcs during heating.
4. After soldering, do not warp the circuit board.

### 12.2 Soldering Iron

Each terminal is to go to the tip of soldering iron temperature less than 350°C for 3 seconds within once in less than the soldering iron capacity 25W. Leave two seconds and more intervals, and do soldering of each terminal. Be careful because the damage of the product is often started at the time of the hand solder.

### 12.3 Repairing

Repair should not be done after the lcs have been soldered. When repairing is unavoidable, a double-head soldering iron should be used (as below figure). It should be confirmed beforehand whether the characteristics of the lcs will or will not be damaged by repairing.

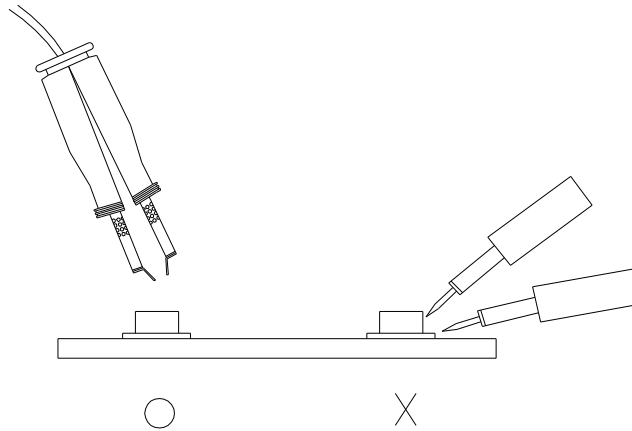

## 13. STORAGE INFORMATION

### 13.1 Storage Condition

1. Devices are packed in moisture barrier bags (MBB) to prevent the products from moisture absorption during transportation and storage. Each bag contains a desiccant.
2. The delivery product should be stored with the conditions shown below:

Storage Temperature	10 to 30°C
Relatively Humidity	below 60%RH

### 13.2 Treatment After Unsealed

1. Floor life (time between soldering and removing from MBB) must not exceed the time shown below:

Floor Life	168 Hours
Storage Temperature	10 to 30°C
Relatively Humidity	below 60%RH

2. When the floor life limits have been exceeded or the devices are not stored in dry conditions, they must be re-baked before reflow to prevent damage to the devices. The recommended conditions are shown below

Temperature	60°C
Re-Baking Time	12 Hours

## 14. TAPE AND REEL DIMENSION

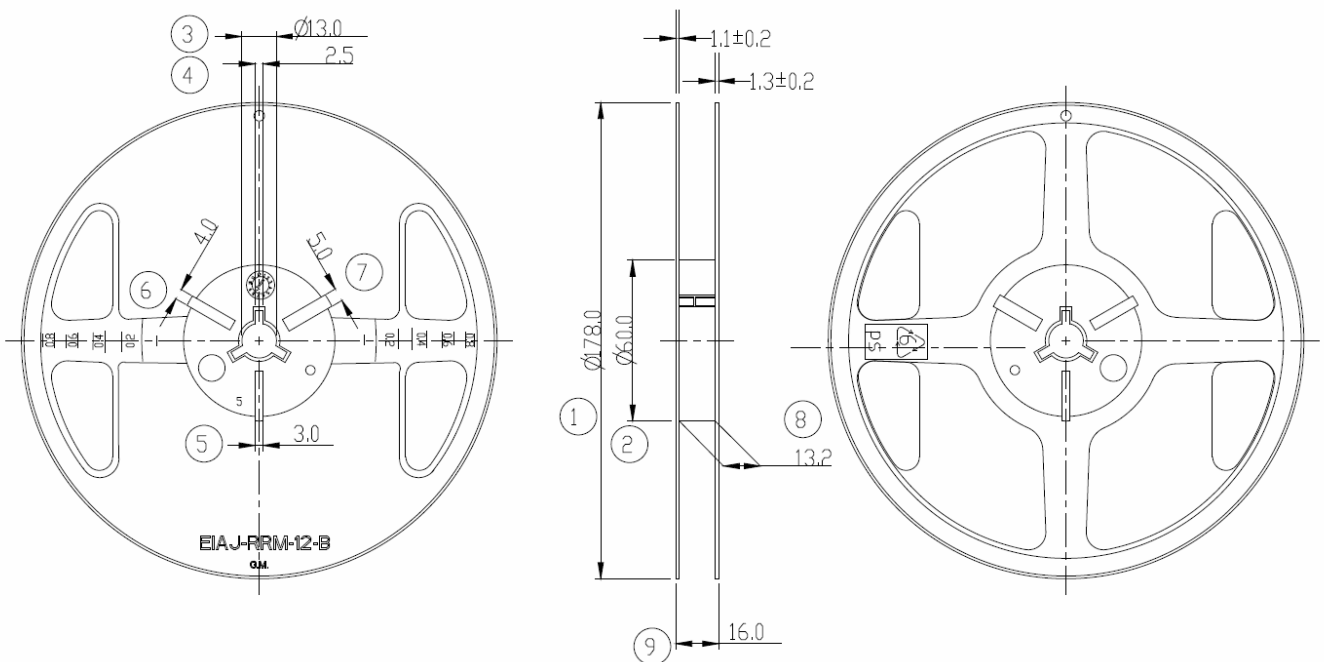
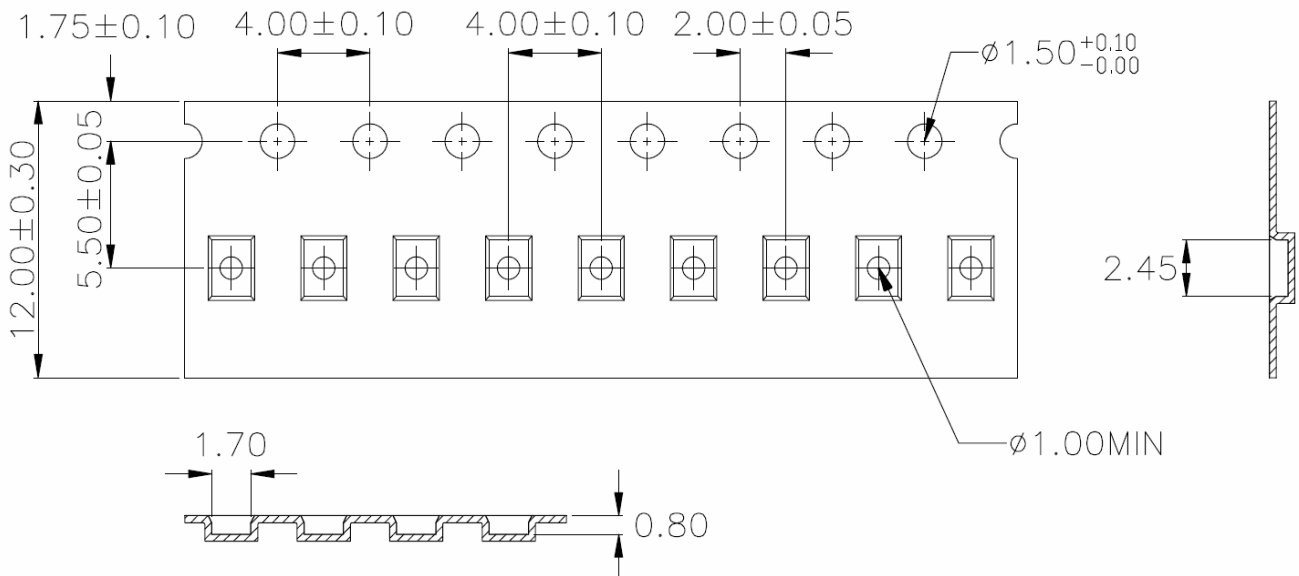

Notes: all linear dimensions are in mm.

## Revision History

Date	Version	Modified Items
2019/06/12	0.9.0	Initial release.

### Important Notice

This document contains information that is proprietary to Sensortek Technology Corp. ("sensortek"), and is subject to change without notice. Any part of this document may not be used, reproduced, duplicated or disclosed in any form or any means without the prior written permission of sensortek.

Sensortek does not warrant or represent that any license, either express or implied, is granted under any sensortek's patent right, copyright, mask work right, or other intellectual property right relating to any combination, machine, or process in which sensortek's products or services are used. In addition, Sensortek does not assume any liability for the occurrence of infringing on any patent or other intellectual property rights of a third party.

Sensortek reserves the right to make corrections, modifications, enhancements, improvements, and other changes to its products and services at any time and to discontinue any product or service without notice. Customers should obtain the latest relevant information before placing orders and should verify that such information is current and complete.