



SANYO Semiconductors DATA SHEET

STK404-120S — Thick-Film Hybrid IC One-Channel Class AB Audio Power Amplifier IC 80W

Overview

The STK404-000S series products are audio power amplifier hybrid ICs that consist of optimally-designed discrete component power amplifier circuits that have been miniaturized using SANYO's unique insulated metal substrate technology (IMST). The adoption of a newly-developed low thermal resistance substrate allows this series of devices to be provided in miniature packages significantly more compact than earlier SANYO products with similar specifications.

Features

- Series of pin compatible power amplifiers ranging from 45W to 180W (10%/1kHz) devices. The same printed circuit board can be used depending on the output power grade.
- Miniature packages
 - 30W to 40W (THD=0.4%, f=20Hz to 20kHz); 44.0mm × 25.6mm × 8.5mm *
 - 50W to 80W (THD=0.4%, f=20Hz to 20kHz); 46.6mm × 25.5mm × 8.5mm *
 - 100W to 120W (THD=0.4%, f=20Hz to 20kHz); 59.2mm × 25.5mm × 8.5mm *

*: Not including the pins.

- Output load impedance: $R_L=6\Omega$
- Allowable load shorted time: 0.3 seconds
- Built-in thermal protection circuit
- Supports the use of standby, muting, and load shorting protection circuits.

Series Organization

These products are organized as a series based on their output capacity.

| Item | Type No. | | | | | | |
|---------------------------------|-------------------------|-------------|-------------------------------------|-------------|-------------|-------------------------|-------------|
| | STK404-050S | STK404-070S | STK404-090S | STK404-100S | STK404-120S | STK404-130S | STK404-140S |
| Output 1 (0.4%/20Hz to 20kHz) | 30W | 40W | 50W | 60W | 80W | 100W | 120W |
| Output 2 (10%/1kHz) | 45W | 60W | 80W | 90W | 120W | 150W | 180W |
| Maximum supply voltage (6Ω) | ±37V | ±43V | ±46V | ±51V | ±59V | ±64V | ±73V |
| Recommended supply voltage (6Ω) | ±26V | ±30V | ±32V | ±35V | ±41V | ±45V | ±51V |
| Remarks | - | | Built-in thermal protection circuit | | | | |
| Package | 44.0mm × 25.6mm × 8.5mm | | 46.6mm × 25.5mm × 8.5mm | | | 59.2mm × 25.5mm × 8.5mm | |

- Any and all SANYO products described or contained herein do not have specifications that can handle applications that require extremely high levels of reliability, such as life-support systems, aircraft's control systems, or other applications whose failure can be reasonably expected to result in serious physical and/or material damage. Consult with your SANYO representative nearest you before using any SANYO products described or contained herein in such applications.
- SANYO assumes no responsibility for equipment failures that result from using products at values that exceed, even momentarily, rated values (such as maximum ratings, operating condition ranges, or other parameters) listed in products specifications of any and all SANYO products described or contained herein.

STK404-120S

Package Dimensions

unit : mm

4204

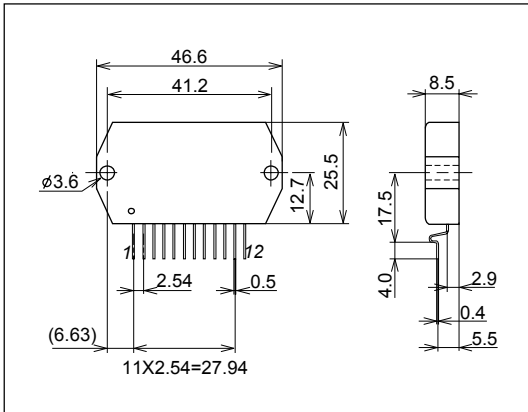

Specifications

Maximum Ratings at $T_a = 25^\circ\text{C}$

| Parameter | Symbol | Conditions | Ratings | Unit |
|---|------------------|--|-------------|---------------------------|
| Maximum supply voltage (Quiescent) | $V_{CC \max(0)}$ | | ± 65 | V |
| Maximum supply voltage | $V_{CC \max(1)}$ | $R_L = 6\Omega$ | ± 59 | V |
| Thermal sensor maximum voltage | V_p | Between pins 1 and 4 | 16 | V |
| Thermal sensor maximum current | I_p | Between pins 1 and 4 | 30 | mA |
| Thermal resistance | θ_{j-c} | Per power transistor | 1.9 | $^\circ\text{C}/\text{W}$ |
| Junction temperature | $T_{j \max}$ | Both the $T_{j \max}$ and the $T_c \max$ conditions must be met. | 150 | $^\circ\text{C}$ |
| IC substrate operating temperature | $T_c \max$ | | 125 | $^\circ\text{C}$ |
| Thermal sensor operating temperature *2 | $T_p \max$ | | 145 | $^\circ\text{C}$ |
| Storage temperature | T_{stg} | | -30 to +125 | $^\circ\text{C}$ |
| Allowable load shorted time *4 | t_s | $V_{CC} = \pm 41.0\text{V}$, $R_L = 6\Omega$, $f = 50\text{Hz}$, $P_O = 80\text{W}$ | 0.3 | s |

Operating Characteristics at $T_c = 25^\circ\text{C}$, $R_L = 6\Omega$ (noninductive load), $R_g = 600\Omega$, $V_G = 30\text{dB}$

| Parameter | Symbol | Conditions *1 | | | | Ratings | | | Unit | |
|----------------------------|------------|---|----------------|-----------------|--------|-------------------|-----------|-----|------------------|----|
| | | $V_{CC}(\text{V})$ | $f(\text{Hz})$ | $P_O(\text{W})$ | THD(%) | min | typ | max | | |
| Output power | $P_O(1)$ | ± 41.0 | 20 to 20k | | 0.4 | 80 | | | W | |
| | $P_O(2)$ | ± 41.0 | 1k | | 10 | | 120 | | | |
| Frequency characteristics | f_L, f_H | ± 41.0 | | 1.0 | | +0 -3dB | 20 to 20k | | Hz | |
| Input impedance | r_i | ± 41.0 | 1k | 1.0 | | | 55 | | $k\Omega$ | |
| Output noise voltage *3 | V_{NO} | ± 49.0 | | | | $R_g = 10k\Omega$ | 1.2 | | mVrms | |
| Quiescent current | I_{CCO} | ± 49.0 | | | | No load | | 50 | mA | |
| Neutral voltage | V_N | ± 49.0 | | | | | -100 | 0 | +100 | mV |
| Thermal sensor resistance | R_p | $T_p = 25^\circ\text{C}$, between pins 1 and 4 | | | | | 470 | | Ω | |
| Thermal sensor temperature | T_p | $R_p = 4.7k\Omega$, between pins 1 and 4 | | | | | 145 | | $^\circ\text{C}$ | |

STK404-120S

- Notes:
1. Unless otherwise noted, a constant-voltage supply must be used during inspection.
 2. The thermal sensor temperature (+125 to +145°C) is designed to prevent incorrect operation, but does not guarantee continued operation of the hybrid IC. The total integrated time this device spends operating in the temperature range +125 to +145°C must not exceed 12 hours.
 3. The output noise voltage values shown are peak values read with a VTVM. However, an AC stabilized (50Hz) power supply should be used to minimize the influence of AC primary side flicker noise on the reading.
 4. Use the transformer power supply circuit shown in the figure below for allowable load shorted time measurement and output noise voltage measurement. This IC is designed assuming that applications will provide a power cut-off or other load-shorting protection function that is activated within 0.3 seconds of the load being shorted.

Designated Transformer Power Supply (MG-250 equivalent)

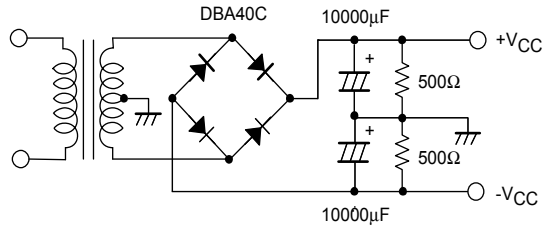

Internal Equivalent Circuit

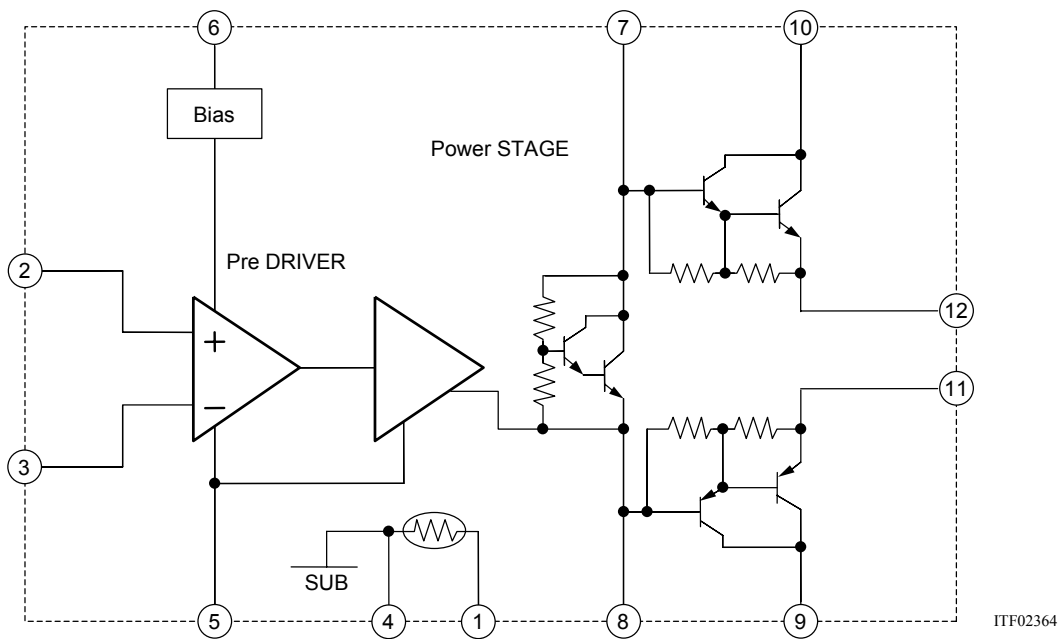

STK404-120S

Sample Application Circuit

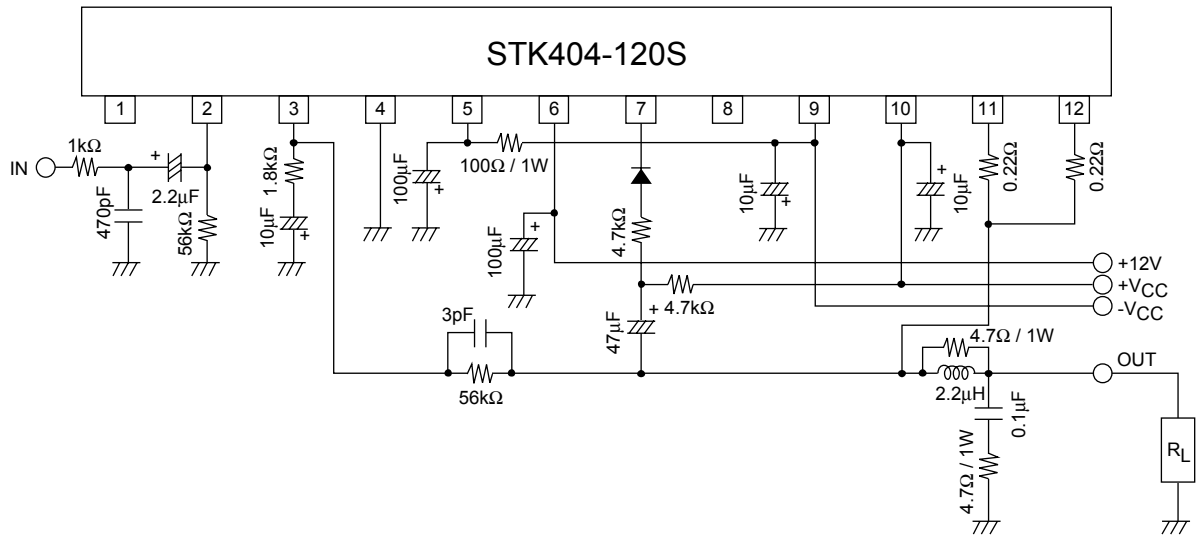

ITF02224

Thermal Design Example

If we define Pd, the total power dissipation on the board when this hybrid IC is in operation, the heat sink thermal resistance, θ_{c-a} , is determined as follows:

Condition 1: The hybrid IC substrate temperature Tc must not exceed 125°C.

$$Pd \times \theta_{c-a} + Ta < 125^{\circ}\text{C} \dots\dots\dots (1)$$

Ta: Guaranteed ambient temperature for the end product.

Condition 2: The junction temperature Tj of each transistor must not exceed 150°C.

$$Pd \times \theta_{c-a} + Pd/N \times \theta_{j-c} + Ta < 150^{\circ}\text{C} \dots\dots\dots (2)$$

N: Number of power transistors

θ_{j-c} : Thermal resistance per power transistor

We take the power dissipation in the power transistors to be Pd evenly distributed across those N power transistors.

If we solve for θ_{c-a} in equations (1) and (2), we get the following inequalities:

$$\theta_{c-a} < (125 - Ta)/Pd \dots\dots\dots (3)$$

$$\theta_{c-a} < (150 - Ta)/Pd - \theta_{j-c}/N \dots\dots\dots (4)$$

The value that satisfies both of these inequalities at the same time is the required heat sink thermal resistance value.

Example:

For actual music signals, it is usual to use a Pd of 1/8 of P_O max, which is the power estimated for continuous signals in this manner. (Note that depending on the particular safety standard used, a value somewhat different from the value of 1/8 used here may be used.)

When V_{CC} = ±41V and R_L = 6Ω, we get the following expression for the total power dissipation on the board, Pd:

$$Pd = 38\text{W (when } 1/8 P_O \text{ max is } 10.0\text{W)} \dots\dots\dots (5)$$

The number, N, of power transistors in the hybrid IC's audio amplifier block is 2. Since the thermal resistance, θ_{j-c} , per transistor is 1.9°C/W, the required heat sink thermal resistance, θ_{c-a} , for a guaranteed ambient temperature Ta of 50°C will be as follows:

$$\text{From inequality (3): } \theta_{c-a} < (125 - 50)/38 = 1.97 \dots\dots\dots (6)$$

$$\text{From inequality (4): } \theta_{c-a} < (150 - 50)/38 - 1.9/2 = 1.68 \dots\dots\dots (7)$$

Therefore, the thermal resistance that satisfies both of these expressions (6 and 7) at the same time is 1.68°C/W.

Note that this thermal design example assumes the use of a constant-voltage power supply, and is only provided as an example for reference purposes. Thermal designs must be tested in an actual end product.

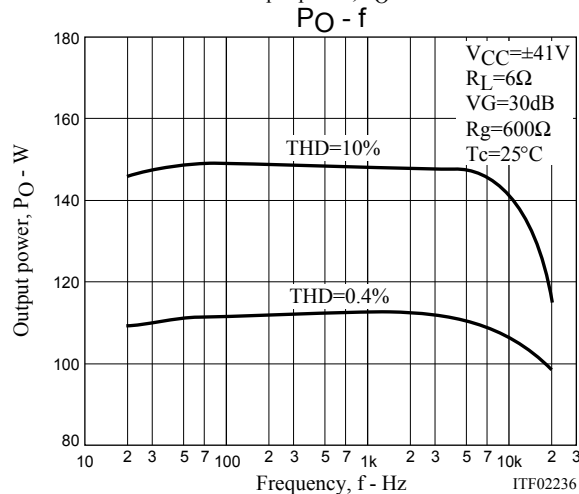
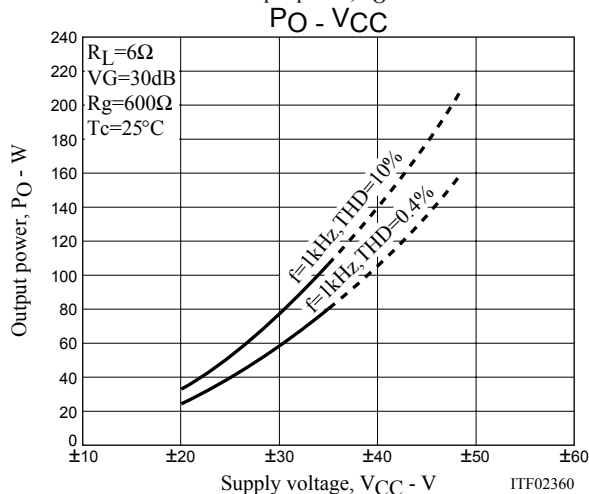
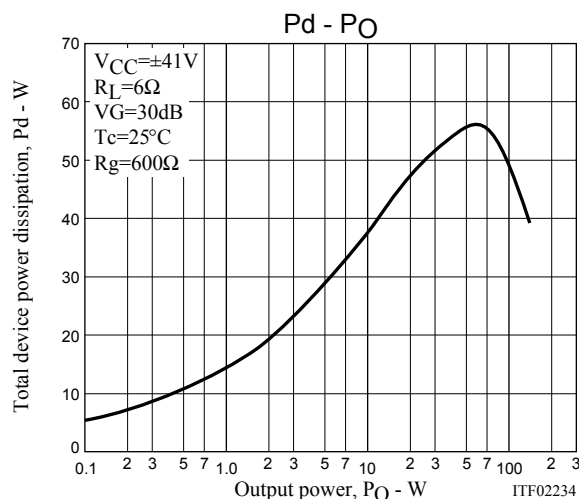
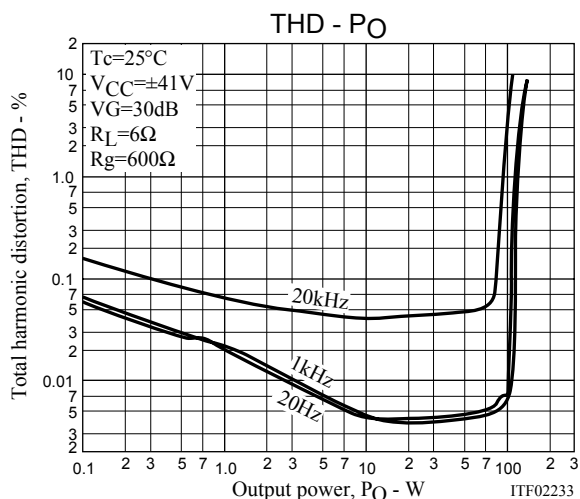

- Specifications of any and all SANYO products described or contained herein stipulate the performance, characteristics, and functions of the described products in the independent state, and are not guarantees of the performance, characteristics, and functions of the described products as mounted in the customer's products or equipment. To verify symptoms and states that cannot be evaluated in an independent device, the customer should always evaluate and test devices mounted in the customer's products or equipment.
- SANYO Electric Co., Ltd. strives to supply high-quality high-reliability products. However, any and all semiconductor products fail with some probability. It is possible that these probabilistic failures could give rise to accidents or events that could endanger human lives, that could give rise to smoke or fire, or that could cause damage to other property. When designing equipment, adopt safety measures so that these kinds of accidents or events cannot occur. Such measures include but are not limited to protective circuits and error prevention circuits for safe design, redundant design, and structural design.
- In the event that any or all SANYO products (including technical data, services) described or contained herein are controlled under any of applicable local export control laws and regulations, such products must not be exported without obtaining the export license from the authorities concerned in accordance with the above law.
- No part of this publication may be reproduced or transmitted in any form or by any means, electronic or mechanical, including photocopying and recording, or any information storage or retrieval system, or otherwise, without the prior written permission of SANYO Electric Co., Ltd.
- Any and all information described or contained herein are subject to change without notice due to product/technology improvement, etc. When designing equipment, refer to the "Delivery Specification" for the SANYO product that you intend to use.
- Information (including circuit diagrams and circuit parameters) herein is for example only; it is not guaranteed for volume production. SANYO believes information herein is accurate and reliable, but no guarantees are made or implied regarding its use or any infringements of intellectual property rights or other rights of third parties.

This catalog provides information as of December, 2005. Specifications and information herein are subject to change without notice.