



SANYO Semiconductors

DATA SHEET

STK433-890-E — Thick-Film Hybrid IC 4-channel class AB audio power IC, 80W×4ch

Overview

The STK433-890-E is 80W×4 channels class-AB audio frequency power amplifier hybrid IC.

Applications

- Audio power amplifiers.

Features

- Pin-to-pin compatible outputs ranging from 60W to 80W
- Can be used to replace the STK433-000/-100 series (30W to 150W/2ch/class-AB), STK415-100Series (80W to 150W/2ch/class H) due to its pin compatibility of ch1/ch2.
2ch class AB (30W to 60W, THD=10%) : STK433-000 series
2ch class AB (80W to 150W, THD=10%) : STK433-100 series
2ch class H (80W to 150W, THD=10%) : STK415-100 series
- Compact package (64.0mm×31.1mm×9.0mm, 78.0mm×44.1mm×9.0mm)
- Output load impedance $R_L=6\Omega$, 8Ω supported.
- Allowable load shorted time: 0.3s
- Allows the use of predesigned applications for standby and mute circuits

Series Models

	STK433-870-E	STK433-890-E
Output 1 (10%/1kHz)	60W×4ch	80W×4ch
Output 2 (0.4%/20Hz to 20kHz)	40W×4ch	50W×4ch
Maximum Rating V_{CC} max (No signal)	±50V	±54V
Maximum Rating V_{CC} max (6Ω)	±44V	±47V
Recommended operating V_{CC} (6Ω)	±37V	±40V
Dimensions (excluding pin height)	64.0mm×31.1mm×9.0mm	78.0mm×44.1mm×9.0mm

■ Any and all SANYO Semiconductor Co.,Ltd. products described or contained herein are, with regard to "standard application", intended for the use as general electronics equipment (home appliances, AV equipment, communication device, office equipment, industrial equipment etc.). The products mentioned herein shall not be intended for use for any "special application" (medical equipment whose purpose is to sustain life, aerospace instrument, nuclear control device, burning appliances, transportation machine, traffic signal system, safety equipment etc.) that shall require extremely high level of reliability and can directly threaten human lives in case of failure or malfunction of the product or may cause harm to human bodies, nor shall they grant any guarantee thereof. If you should intend to use our products for applications outside the standard applications of our customer who is considering such use and/or outside the scope of our intended standard applications, please consult with us prior to the intended use. If there is no consultation or inquiry before the intended use, our customer shall be solely responsible for the use.

■ Specifications of any and all SANYO Semiconductor Co.,Ltd. products described or contained herein stipulate the performance, characteristics, and functions of the described products in the independent state, and are not guarantees of the performance, characteristics, and functions of the described products as mounted in the customer's products or equipment. To verify symptoms and states that cannot be evaluated in an independent device, the customer should always evaluate and test devices mounted in the customer's products or equipment.

STK433-890-E

Specifications

Absolute Maximum Ratings at Ta=25°C (excluding rated temperature items), Tc=25°C unless otherwise specified

Parameter	Symbol	Conditions	Ratings	Unit
Maximum supply voltage	V _{CC} max (0)	No signal	±54	V
	V _{CC} max (1)	When signals are present, R _L ≥6Ω	±47	V
	V _{CC} max (2)	When signals are present, R _L =4Ω	±40	V
Minimum operating supply voltage	V _{CC} min		±10	V
Stand-by pin maximum voltage	VST OFF max		-0.3 to +5.5	V
Thermal resistance	θj-c	Per one power transistor	2.1	°C/W
Junction temperature	Tj max	Both the Tj max and Tc max conditions must be met.	150	°C
IC substrate operating temperature	Tc max		125	°C
Storage temperature	Tstg		-30 to +125	°C
Allowable load shorted time	ts	V _{CC} =±34V, R _L =6Ω, f=50Hz, P _O =50W, 1ch drive	0.3	s

Operating Characteristics at Tc=25°C, R_L=6Ω (Non-inductive Load), Rg=600Ω, VG=30dB, unless otherwise specified

Parameter	Symbol	Conditions *2					Ratings			unit
		V _{CC} (V)	f (Hz)	P _O (W)	THD (%)		min	typ	max	
Output power *1	P _O (1)	±34	20 to 20k		0.4		47	50		W
	P _O (2)	±34	1k		10			80		
Total harmonic distortion *1	THD (1)	±34	20 to 20k	5.0		VG=30dB		0.02	0.4	%
	THD (2)	±34	1k							
Frequency characteristics *1	f _L , f _H	±34		1.0		+0 -3dB	20 to 50k			Hz
Input impedance	ri	±34	1k	1.0				55		kΩ
Output noise voltage *3	V _{NO}	±40				Rg=2.2kΩ			1.0	mVrms
Quiescent current	I _{CCO}	±40				No loading	40	90	140	mA
Stand-By Current	ICST	±40				VST=0V		0.05		mA
Output neutral voltage	V _N	±40					-70	0	+70	mV
#13 voltage when standby ON *5	VST ON	±34				Standby		0	0.6	V
#13 voltage when standby OFF *5	VST OFF	±34				Operating	2.5	3.0	5.5	V

[Remarks]

- *1. For 1-channel operation
- *2. Unless otherwise specified, use a constant-voltage power supply to supply power when inspections are carried out.
- *3. The output noise voltage values shown are peak values read with a VTVM. However, an AC stabilized (50Hz) power supply should be used to minimize the influence of AC primary side flicker noise on the reading.
- *4. Use the designated transformer power supply circuit shown in the figure below for the measurement of allowable load shorted time and output noise voltage.
- *5. The impression voltage of ' #13 (Stand-By) pin ' must not exceed the maximum rating. Power amplifier operates by impressing voltage +2.5 to +5.5V to ' #13 (Stand-By) pin '.
- * Please connect -Pre V_{CC} pin (#1 pin) with the stable minimum voltage and connect so that current does not flow in by reverse bias.
- * Thermal design must be implemented based on the conditions under which the customer's end products are expected to operate on the market.
- * The case of this Hybrid-IC is using thermosetting silicon adhesive (TSE322SX).
- * Weight of HIC: 37.0g
Outer carton dimensions (W×L×H): 452mm×325mm×192mm

Designated transformer power supply (MG-200 equivalent)

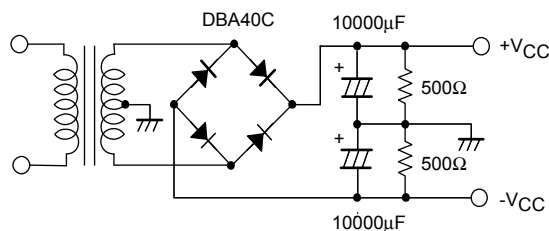

STK433-890-E

Package Dimensions

unit:mm (typ)

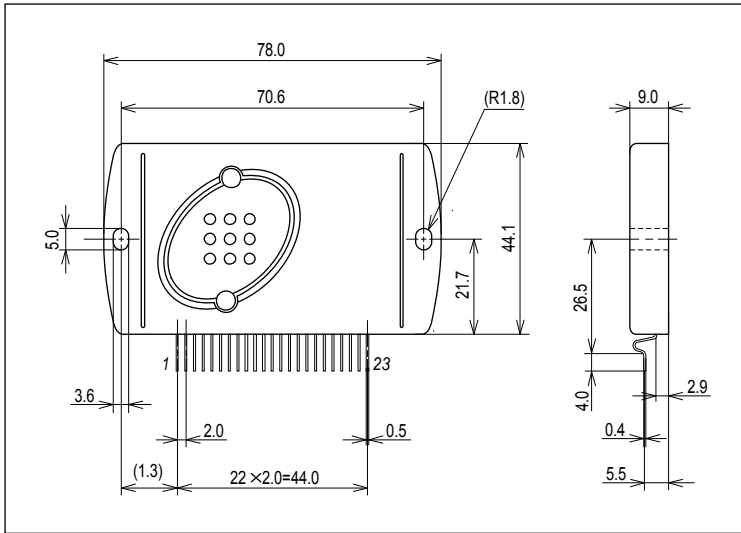

RoHS directive pass

Equivalent Circuit

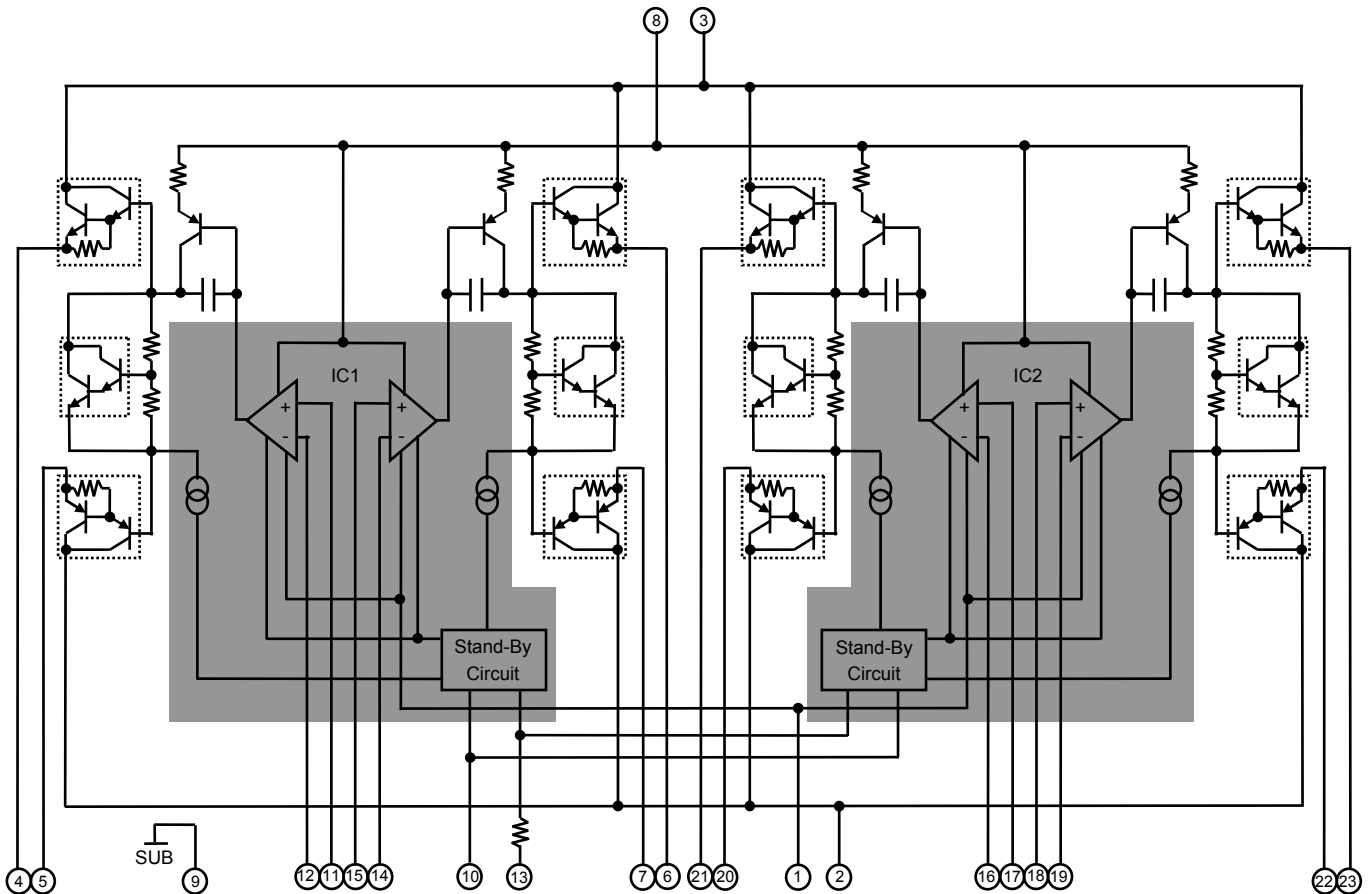

STK433-890-E

Application Circuit

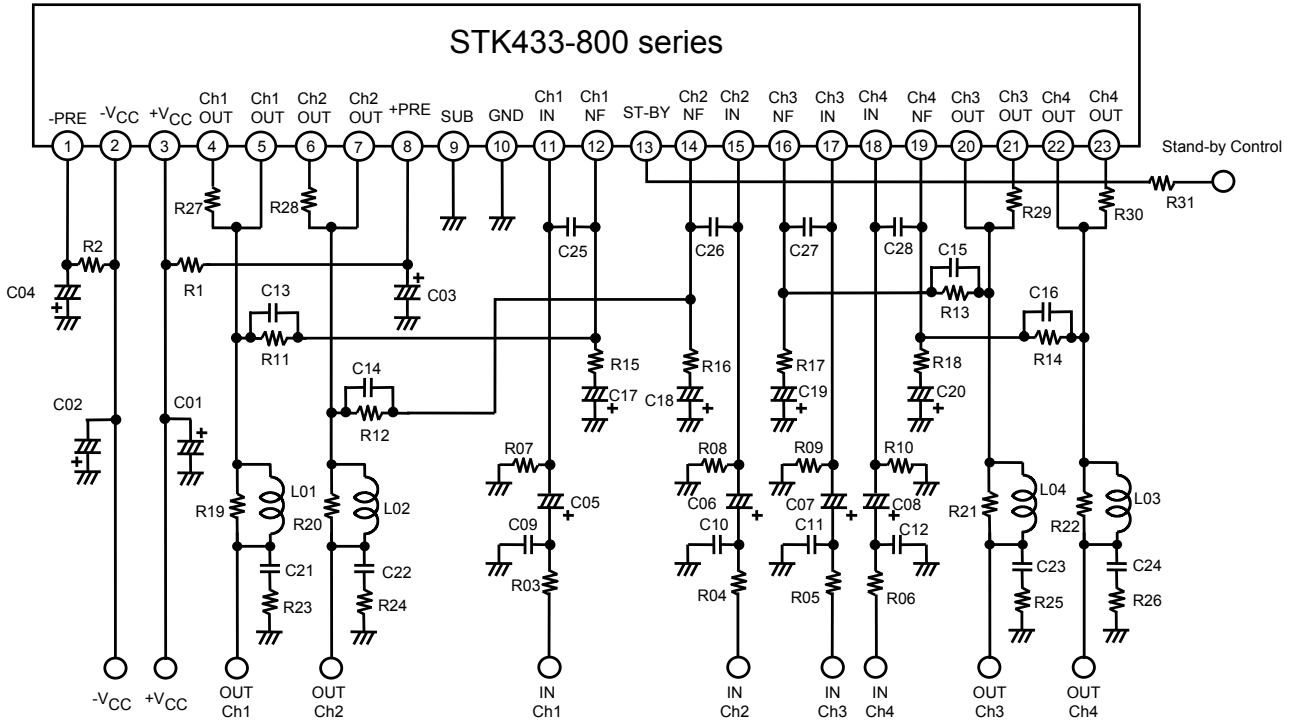

PCB Layout Example

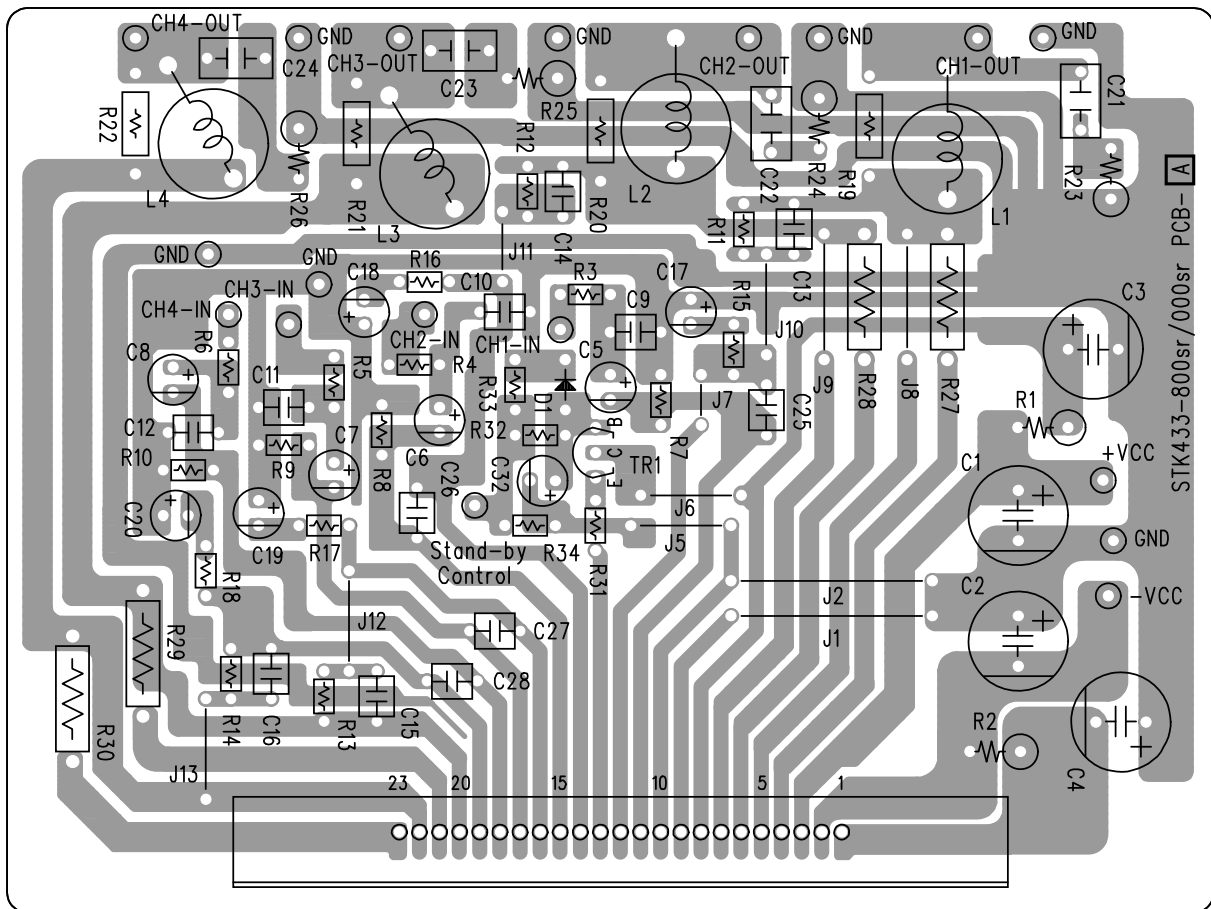

STK433-890-E

Recommended Values for Application Parts (for the test circuit)

Parts Location	Recommended value	Circuit purpose	Above Recommended value	Below Recommended value
R01, R02	100Ω/1W	Resistance for Ripple filter. (Fuse resistance is recommended. Ripple filter is constituted with C03, C04.)	Short-through current may decrease at high frequency.	Short-through current may increase at high frequency.
R03, R04, R05, R06	1kΩ	Resistance for input filters.	-	-
R07, R08, R09, R10	56kΩ	Input impedance is determined.	Output neutral voltage (VN) shift. (It is referred that R07=R11, R08=R12, R09=R13, R10=R14)	
R11, R12, R13, R14	56kΩ	Voltage Gain (VG) is determined with R15, R16, R17, R18.	-	-
R15, R16, R17, R18	1.8kΩ	Voltage Gain (VG) is determined with R11, R12, R13, R14. (As for VG, it is desirable to set up by R15, R16, R17, R18.)	It may oscillate. (VG<30dB)	With especially no problem
R19, R20, R21, R22	4.7Ω	Noise absorption resistance.	-	-
R23, R24, R25, R26	4.7Ω/1W	Resistance for oscillation prevention.	-	-
R27, R28, R29, R30	0.22Ω ±10%, 5W	Output emitter resistor (Metal-plate resistor is recommended.)	Decrease of maximum output power	It may cause thermal runaway
R31	Note *5	Select restriction resistance, for the impression voltage of '#17(Stand-By) pin' must not exceed the maximum rating.		
C01, C02	100μF/ 100V	Capacitor for oscillation prevention. • Locate near the HIC as much as possible. • Power supply impedance is lowered and stable operation of the IC is carried out. (Electrolytic capacitor is recommended.)	-	-
C03, C04	100μF/ 100V	Decoupling capacitor • The ripple ingredient mixed in an input side is removed from a power supply line. (Ripple filter is constituted with R01, R02.)	The change in the ripple ingredient mixed in an input side from a power supply line	
C05, C06, C07, C08	2.2μF/50V	Input coupling capacitor. (for DC current prevention.)	-	
C09, C10, C11, C12	470pF	Input filter capacitor • A high frequency noise is reduced with the filter constituted by R03, R04, R05, R06.	-	
C13, C14, C15, C16	5pF	Capacitor for oscillation prevention.	It may oscillate.	
C17, C18, C19, C20	10μF/10V	Negative feedback capacitor. • The cutoff frequency of a low cycle changes. ex / $f_L = 1/2\pi \cdot C13 \cdot R11$)	The voltage gain (VG) of low frequency is extended. However, the pop noise at the time of a power supply injection also becomes large.	The voltage gain (VG) of low frequency decreases.
C21, C22, C23, C24	0.1μF	Capacitor for oscillation prevention. (Mylar capacitors are recommended.)	It may oscillate.	
C25, C26, C27, C28	100pF	Capacitor for oscillation prevention.	It may oscillate.	
L01, L02, L03, L04	3μH	Coil for oscillation prevention.	With especially no problem	It may oscillate.

STK433-890-E

STK433-800 series PCB PARTS LIST

PCB Name: STK433-800 series PCB[A]

Location No.	PARTS	RATING	Component	
			STK433-870-E	STK433-890-E
R01, R02	ERG1SJ101	100Ω, 1W	○	○
R03, R04, R05, R06	RN16S102FK	1kΩ, 1/6W	○	○
R07, R08, R09, R10, R11, R12, R13, R14	RN16S563FK	56kΩ, 1/6W	○	○
R15, R16, R17, R18	RN16S182FK	1.8kΩ, 1/6W	○	○
R19, R20, R21, R22	RN14S4R7FK	4.7Ω, 1/4W	○	○
R23, R24, R25, R26	ERX1SJ4R7	4.7Ω, 1W	○	○
R27, R28, R29, R30	ERX2SJR22	0.22Ω, 5W	○	○
C01, C02, C03, C04	100MV100HC	100μF, 100V	○	○
C05, C06, C07, C08 (*1)	50MV2R2HC	2.2μF, 50V	○	○
C09, C10, C11, C12	DD104-63B471K50	470pF, 50V	○	○
C13, C14, C15, C16	DD104-63CJ0*0C50	***pF, 50V	3pF	5pF
C17, C18, C19, C20 (*1)	10MV10HC	10μF, 10V	○	○
C21, C22, C23, C24	ECQ-V1H104JZ	0.1μF, 50V	○	○
C25, C26, C27, C28	DD104-63B101K50	100pF, 50V	○	○
L01, L02, L03, L04	-	3μH	○	○
Stand-By Control Circuit	Tr1	2SC3332 (Reference)	$V_{CE} \geq 54V, I_C \geq 10mA$	
	D1	GMB01 (Reference)	Di	
	R31	RN16S132FK	1.3kΩ, 1/6W	○
	R32	RN16S333FK	33kΩ, 1/6W	○
	R33	RN16S102FK	1kΩ, 1/6W	○
	R34	RN16S202FK	2kΩ, 1/6W	○
	C32	10MV33HC	33μF, 10V	○
J1, 2, 5, 6, 7, 8, 9, 10, 11, 12, 13	-	-	○	○

(*1) Capacitor mark "A" side is "-" (negative).

STK433-890-E

Pin Assignments

[STK433-800 series Pin Layout]

	1	2	3	4	5	6	7	8	9	10	11	12	13	14	15	16	17	18	19	20	21	22	23	
2ch classAB/2.00mm																								
STK433-000-E sr 30W to 60W (JEITA)×2ch Package Size/ 47.0mm×25.6mm×9.0mm	- P R E	- V C C	+ V C C	O U C C	O U C C	O U C C	O U C C	+ P R E	S U B	G N D	I N C H 1	N F C H 1	S T A N C H 2	N F C H 2	I N C H 2									
4ch classAB/2.00mm																								
STK433-800-E sr 60W to 80W (JEITA)×4ch Package Size/ 64.0mm×31.1mm×9.0mm 78.0mm×44.1mm×9.0mm	- P R E	- V C C	+ V C C	O U C C	O U C C	O U C C	O U C C	+ P R E	S U B	G N D	I N C H 1	N F C H 1	S T A N C H 2	N F C H 2	I N C H 3	N F C H 3	I N C H 4	N F C H 4	O U T 3	O U T 3	O U T 4	O U T 4	O U T 4	O U T 4

Evaluation Board Characteristics

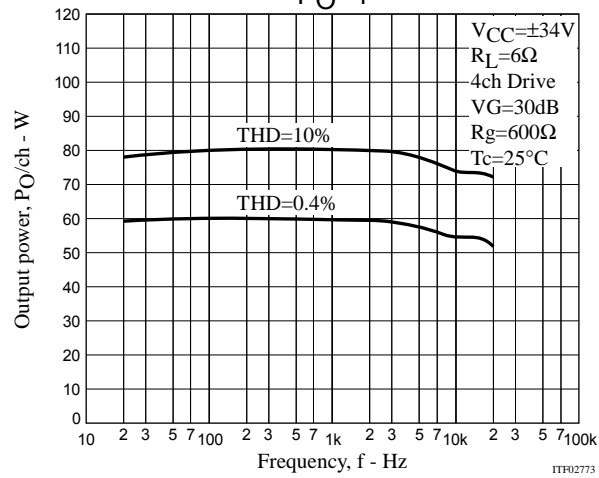
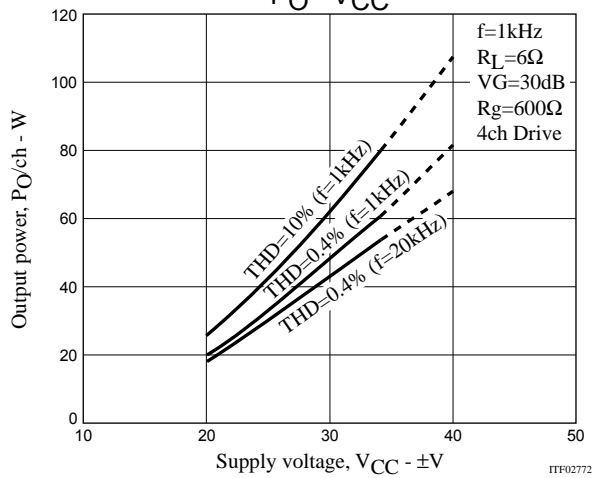
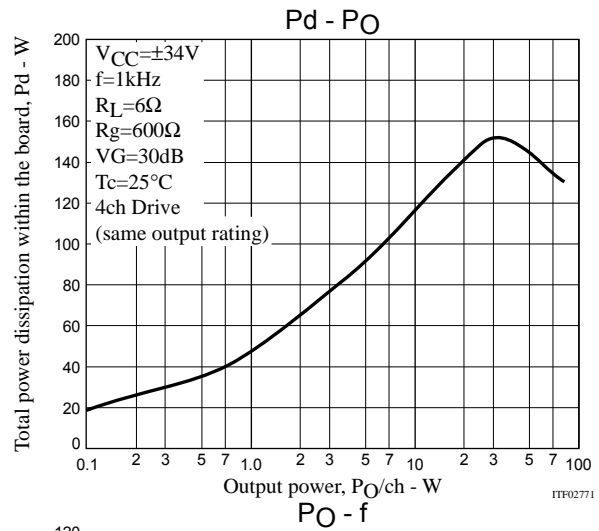
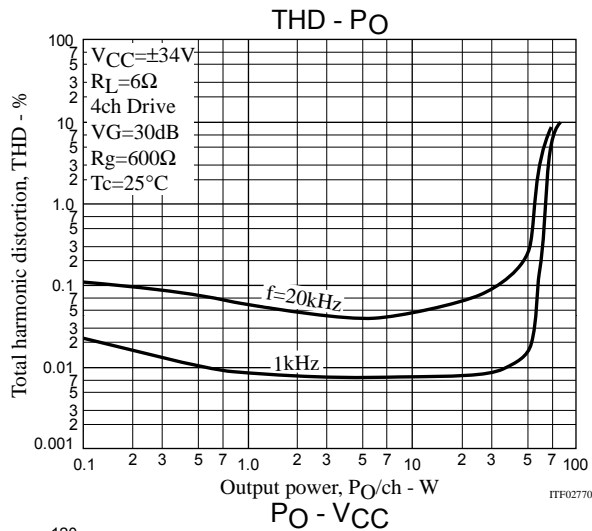

STK433-890-E

[Thermal Design Example for STK433-890-E ($R_L = 6\Omega$)]

The thermal resistance, θ_{c-a} , of the heat sink for total power dissipation, P_d , within the hybrid IC is determined as follows.

Condition 1: The hybrid IC substrate temperature, T_c , must not exceed 125°C .

$$P_d \times \theta_{c-a} + T_a < 125^\circ\text{C} \dots\dots\dots (1)$$

T_a : Guaranteed ambient temperature for the end product

Condition 2: The junction temperature, T_j , of each power transistor must not exceed 150°C .

$$P_d \times \theta_{c-a} + P_d/N \times \theta_{j-c} + T_a < 150^\circ\text{C} \dots\dots\dots (2)$$

N : Number of power transistors

θ_{j-c} : Thermal resistance per power transistor

However, the power dissipation, P_d , for the power transistors shall be allocated equally among the number of power transistors.

The following inequalities result from solving equations (1) and (2) for θ_{c-a} .

$$\theta_{c-a} < (125 - T_a)/P_d \dots\dots\dots (1)'$$

$$\theta_{c-a} < (150 - T_a)/P_d - \theta_{j-c}/N \dots\dots\dots (2)'$$

Values that satisfy these two inequalities at the same time represent the required heat sink thermal resistance.

When the following specifications have been stipulated, the required heat sink thermal resistance can be determined from formulas (1)' and (2)' .

- Supply voltage V_H, V_L
- Load resistance R_L
- Guaranteed ambient temperature T_a

[Example]

When the IC supply voltage, V_{CC} , is $\pm 34\text{V}$ and R_L is 6Ω , the total power dissipation, P_d , within the hybrid IC, will be a maximum of 152W at 1kHz for a continuous sine wave signal according to the P_d - P_O characteristics.

For the music signals normally handled by audio amplifiers, a value of $1/8P_O$ max is generally used for P_d as an estimate of the power dissipation based on the type of continuous signal. (Note that the factor used may differ depending on the safety standard used.)

This is:

$$P_d \approx 98.0\text{W} \quad (\text{when } 1/8P_O \text{ max.} = 6.25\text{W}).$$

The number of power transistors in audio amplifier block of these hybrid ICs, N , is 8, and the thermal resistance per transistor, θ_{j-c} , is 2.1°C/W . Therefore, the required heat sink thermal resistance for a guaranteed ambient temperature, T_a , of 50°C will be as follows.

$$\begin{aligned} \text{From formula (1)'} \quad \theta_{c-a} &< (125 - 50)/98.0 \\ &< 0.76 \end{aligned}$$

$$\begin{aligned} \text{From formula (2)'} \quad \theta_{c-a} &< (150 - 50)/98.0 - 2.1/8 \\ &< 0.75 \end{aligned}$$

Therefore, the value of 0.75°C/W , which satisfies both of these formulae, is the required thermal resistance of the heat sink.

Note that this thermal design example assumes the use of a constant-voltage power supply, and is therefore not a verified design for any particular user's end product.

STK433-800-E series Application Explanation

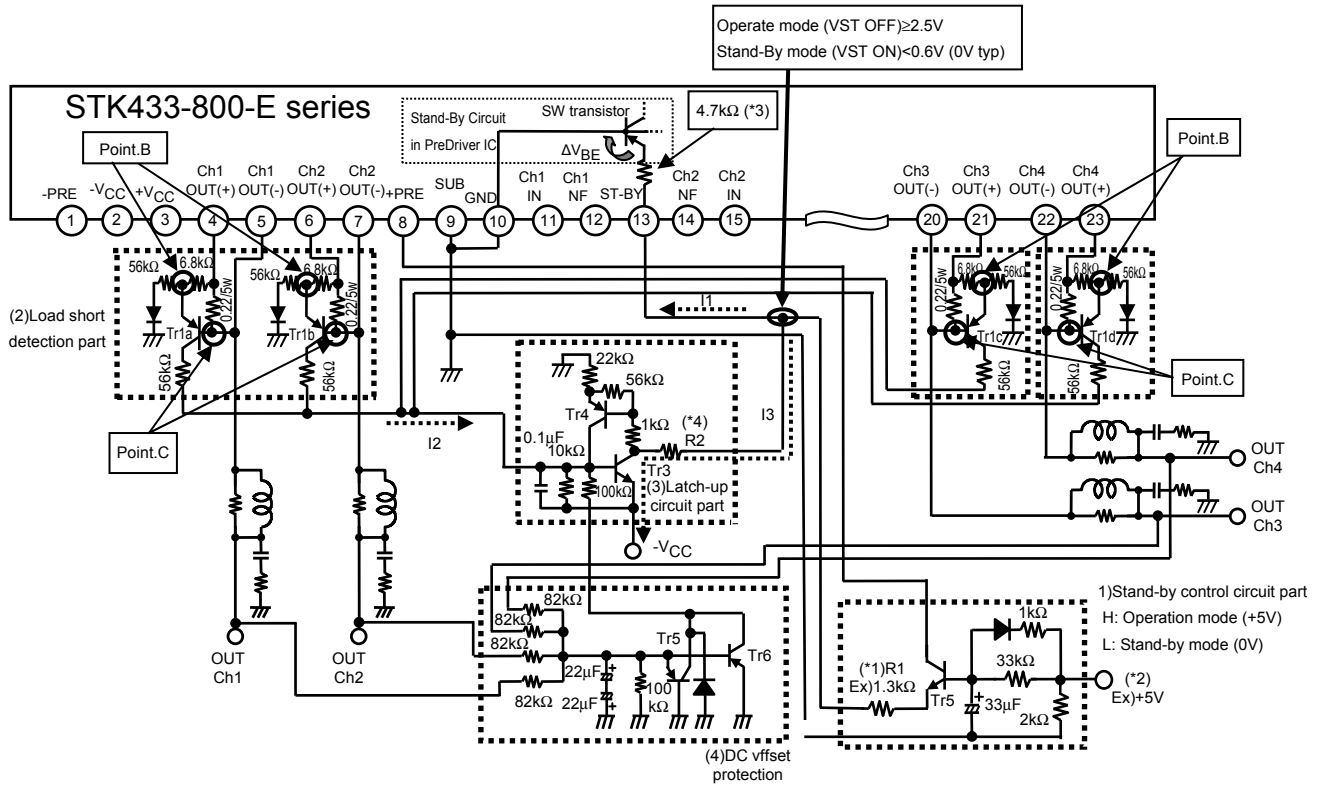

A protection application circuit of STK433-800-E series consists of each block of (1)-(4).

- (1)Stand-by control circuit part
- (2)Load short detection part
- (3)Latch-up circuit part
- (4)DC voltage protection part

1)Stand-by control circuit part
About #13 pin reference voltage VST.

<1>Operation Mode

The SW transistor of Pre-driver IC is turned on at $VST \geq 2.5V$, and the amplifier becomes operation mode.
ex)at $VST (min) = 2.5V$
 $VST = (*2) \times IST + 0.6V \rightarrow 2.5V = 4.7k\Omega \times IST + 0.6V$ therefore, $I1 \approx 0.40mA$

<2>Stand-by mode

The SW transistor of Pre-driver IC is turned off at $VST \leq 0.6V$ (typ 0V), and the amplifier becomes Stand-by mode.
ex)at $VST = 0.6V$
 $VST = (*2) \times IST + 0.6V \rightarrow 0.6V = 4.7k\Omega \times IST + 0.6V$ therefore, $I1 \approx 0mA$

(*1)Resistance for restriction

Please set R1 for the voltage (VST) of the Stand-By terminal to become ratings (+2.5V to 5.5V (typ 3.0V)).

(*2)Please supply the Stand-by Control voltage by the microcomputer etc.

(*3)The limitation resistance is built into hybrid IC internal (#13pin) and 4.7kΩ is built into.

2)Load short detection part

TR1 (a, b, c, d) doesn't move by normal operation. Because, Point.B - Point.C < 0.6V.

Therefore load short detection part doesn't operate.

But, When a load short-circuited, TR1 (or TR2) operate(Point.B - Point.C > 0.6V), and an electric current 'I2' flows.

STK433-890-E

3) Latch-up circuit part

When I2 was supplied to latch-up circuit, TR3 operate.

VST becomes Stand-by mode (0V) when TR3 operates (I3 flows), the power amplifier is protected.

Stand-by mode is maintained when once TR3 operates because TR3 and TR4 compose the thyristor.

It is necessary to make the Stand-By Control voltage (*2) L (0V) once to release Stand-by mode and to make the power amplifier operate again.

After, when Stand-By Control (*2) is returned to H (ex, +5V), it operates again.

(*4) I3 is changed depending on the power-supply voltage ($-V_{CC}$).

Please set resistance (R2) to become $I1 < I3$ by the following calculation types.

$$I1 \leq I3 = V_{CC}/R2$$

4) DC offset protection part

DC offset protection works at applying VDC (+), VDC (-) $\approx 0.5V$ (typ) to 'OUT (ch1 to ch4)', then HIC will shutdown (Stand-by mode).

It is necessary to make the Stand-By Control voltage (*2) L (0V) once to release Stand-by mode.

The power amplifier operates again after Stand-By Control (*2) return to H(ex, +5V).

Please set the protection level by the resistance of '82k Ω '.

Moreover, please set the time constant by '22 μ /22 μ ' so as not to mis-detect it when the audio signal is output.

- SANYO Semiconductor Co.,Ltd. assumes no responsibility for equipment failures that result from using products at values that exceed, even momentarily, rated values (such as maximum ratings, operating condition ranges, or other parameters) listed in products specifications of any and all SANYO Semiconductor Co.,Ltd. products described or contained herein.
- SANYO Semiconductor Co.,Ltd. strives to supply high-quality high-reliability products, however, any and all semiconductor products fail or malfunction with some probability. It is possible that these probabilistic failures or malfunction could give rise to accidents or events that could endanger human lives, trouble that could give rise to smoke or fire, or accidents that could cause damage to other property. When designing equipment, adopt safety measures so that these kinds of accidents or events cannot occur. Such measures include but are not limited to protective circuits and error prevention circuits for safe design, redundant design, and structural design.
- In the event that any or all SANYO Semiconductor Co.,Ltd. products described or contained herein are controlled under any of applicable local export control laws and regulations, such products may require the export license from the authorities concerned in accordance with the above law.
- No part of this publication may be reproduced or transmitted in any form or by any means, electronic or mechanical, including photocopying and recording, or any information storage or retrieval system, or otherwise, without the prior written consent of SANYO Semiconductor Co.,Ltd.
- Any and all information described or contained herein are subject to change without notice due to product/technology improvement, etc. When designing equipment, refer to the "Delivery Specification" for the SANYO Semiconductor Co.,Ltd. product that you intend to use.
- Information (including circuit diagrams and circuit parameters) herein is for example only; it is not guaranteed for volume production.
- Upon using the technical information or products described herein, neither warranty nor license shall be granted with regard to intellectual property rights or any other rights of SANYO Semiconductor Co.,Ltd. or any third party. SANYO Semiconductor Co.,Ltd. shall not be liable for any claim or suits with regard to a third party's intellectual property rights which has resulted from the use of the technical information and products mentioned above.

This catalog provides information as of May, 2010. Specifications and information herein are subject to change without notice.